

AUDIO ENGINEERING

JANUARY
1952
35c

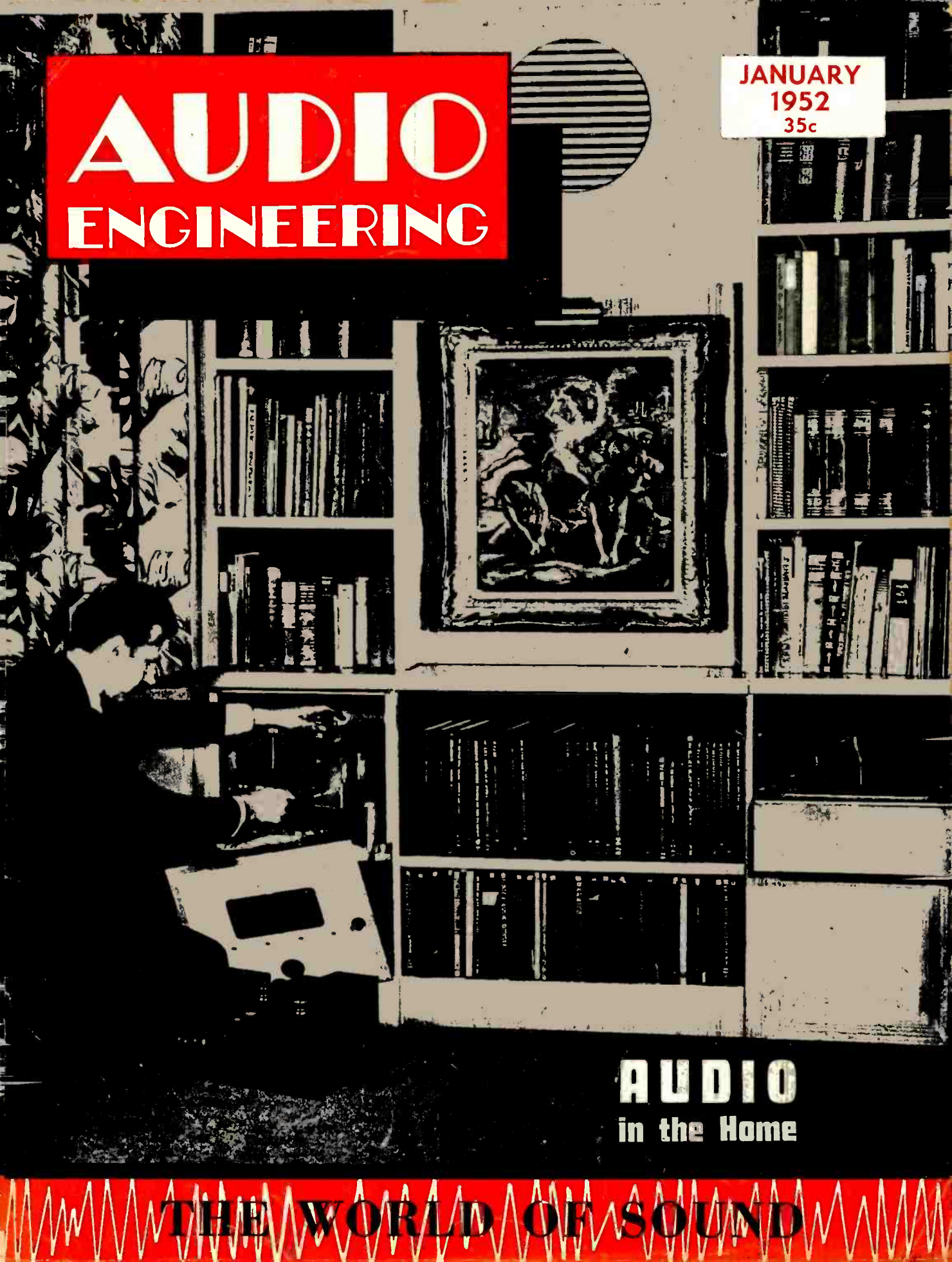

AUDIO
in the Home

THE WORLD OF SOUND

discs or tape
 it's **audio** for
consistent, uniform
quality



audiodiscs* For more than 12 years, Audiodiscs have consistently set the standards for the finest professional performance in instantaneous and master disc recording. Their flawless perfection, wide-range frequency response, extremely low surface noise at all diameters and complete freedom from humidity effects are just a few of the reasons why Audiodiscs are first choice with professional recordists from coast to coast. They know from long experience that they can depend on Audio for the *consistent, uniform quality* that is so essential in modern sound recording work.

audiotape* Wherever professional-quality magnetic recordings are made, the trend is to Audiotape. That's because Audiotape is made *by audio engineers for audio engineers* — with the right combination of properties for finest performance in any tape recorder. Produced on Audio's highly specialized precision coating machines, Audiotape has achieved unequalled *uniformity* of output — plus maximum output with minimum distortion at practical bias range. What's more, it's less sensitive to bias changes, has no audible low-frequency modulation noise, and is guaranteed *splice-free* in both 1250 and 2500 ft. sizes, plastic base. In every respect, Audiotape meets the exacting standards of quality and performance which have characterized Audiodiscs for more than a decade.

audiofilm* extends the advantages of finest quality magnetic recording to motion picture and TV applications. Available in 16mm, 17½mm and 35mm sizes.

audiopoints* are precision matched recording and reproducing styli available in types and sizes to meet the precise requirements for every phase of disc recording work.

NEW Free
 Handbook on
 The Fundamentals
 of Magnetic Recording



This completely new and up-to-the-minute technical manual contains 50 pages of valuable information on basic magnetic principles and tape performance. Professional recordists will find it extremely interesting and helpful — an important addition to their reference files. A request on your business letterhead will bring you a free copy by return mail.

Write to Audio Devices, Dept. A3.



*Trade Mark

AUDIO DEVICES, Inc.

444 MADISON AVE., NEW YORK 22, N. Y.
 Export Dept.: 13 East 40th St., New York 16, N. Y., Cables "ARLAB"

Audiodiscs are manufactured in the U.S.A. under exclusive license from PYRAL, S.A.R.L., Paris

Successor to **RADIO** —Established 1917

AUDIO ENGINEERING

INCLUDING



C. G. McProud, Editor

Ladd Haystead, Publisher

Harrie K. Richardson, Associate Editor

Luci Turner, Production Manager

S. L. Cahn, Advertising Director

Lucille Carty, Circulation Manager

H. N. Reizes, Advertising Manager

Editorial Advisory Board

Howard A. Chinn

John D. Colvin

C. J. LeBel

J. P. Maxfield

George M. Nixon



Representatives

H. Thorpe Covington, Special Representative
677 N. Michigan Ave., Chicago 11, Ill.
Sanford R. Cowan, Mid-West Sales
67 W. 44th St., New York 18, N. Y.
James C. Galloway, Pacific Coast Sales
816 W. 5th St., Los Angeles 17, Calif.
Technical Book & Magazine Co.
297 Swanston St., Melbourne, C. I.
Victoria, Australia

CONTENTS

JANUARY, 1952

Vol. 36, No. 1

Audio Patents—Richard H. Dorf	2
Letters	6
Editor's Report	10
The Design of Compensated Volume Controls—Part 1—Emerick Toth	13
Design for Smooth Response—Vern Yeich	15
The Two Types of Theatre Video—John W. Sims	16
Audio in the Home—William C. Shrader	18
Music's the Thing—Irving Green and Melvin C. Sprinkle	20
Horn-Loaded Bass Speaker—Earl R. Meissner and L. K. Andrews	22
Two Preamplifiers for Magnetic Pickups—George Ellis Jones, Jr.	24
Record Revue—Edward Tatnall Canby	28
New Products	32
New Literature	45
Employment Register	46
Industry Notes	47
Industry People	47
Advertising Index	48

COVER

Technician making an installation of a tuner in a typical—and very attractive—custom-built residence music system. There is no limit to the variety of cabinetry or built-in facilities when the desire for better sound becomes implanted in the mind of a music lover—limitations are only those imposed by the physical size of the components and the loudspeaker enclosure. Photograph through courtesy of Radio-Wire-Television, Inc., New York

RADIO MAGAZINES, INC., 342 MADISON AVE., NEW YORK 17, N. Y.

AUDIO ENGINEERING (title registered U. S. Pat. Off.) is published monthly at 10 McGovern Ave., Lancaster, Pa., by Radio Magazines, Inc., D. S. Potts, President; Henry A. Schober, Secretary-Treasurer. Executive and Editorial Offices: 342 Madison Avenue, New York 17, N. Y. Subscription rates—United States, U. S. Possessions and Canada, \$3.00 for 1 year, \$5.00 for 2 years; elsewhere \$4.00 per year. Single copies 35c. Printed in U. S. A. All rights reserved. Entire contents copyright 1951 by Radio Magazines, Inc. Entered as Second Class Matter February 9, 1950 at the Post Office, Lancaster, Pa. under the Act of March 3, 1879.



You may own the finest pickup, amplifier and speaker that money can buy... yet you'll get poor reproduction if your TURNTABLE has excessive wow, hum or rumble!

REK--KUT

... offers a complete range of 12" Turntable models to match your present high-fidelity equipment and your own pocketbook. Not every sound system requires the most expensive turntable... your turntable must be chosen to complement your other components. Each REK-O-KUT Turntable carries an engineering specification which enables your Sound Dealer to select the appropriate unit. The quality and workmanship of every REK-O-KUT Turntable, from our most economically-priced model, to our highest priced professional machine is identical... price differential is dependent solely upon the type of materials used.



MODEL LP-743

3-Speed 12" Turntable
Induction type motor, designed for smooth, vibration-free operation. Instantaneous speed changes without stopping turntable or removing disc\$54.95 Net



MODEL CVS-12

All-Speed Continuously-Variable Turntable
Plays all records, 6" to 16" and broadcast transcriptions, not only at the three normal speeds, BUT AT ANY SPEED from 25 to 100 RPM. You play your records at the EXACT SPEED at which they were recorded, or at any variation of speed or pitch which gives you maximum pleasure. A "must" for serious music lovers, pro musicians, schools, dance studios, etc.\$84.95 Net

MODELS T-12H & T-43H

2-Speed 12" Turntables

The only 12" dual-speed turntables that meet the standards for speed regulation and WOW content specified by the National Association of Broadcasters.



Recommended for use with ULTRA HIGH FIDELITY Amplifiers and Speaker Systems.

MODELS	MOTOR	SPEED	PRICE
T-12 H*	Hysteresis Synchronous	78-33%	\$119.95
T-43 H*	Hysteresis Synchronous	45-33%	\$119.95
T-12	4 Pole Induction	78-33%	\$84.95
T-43	4 Pole Induction	45-33%	\$84.95

* Delivery limited to very short supply of Hysteresis motors.

See... hear... compare REK-O-KUT Turntables, Phonographs and Professional Disc Recorders at leading Music Stores, Audio-Visual Dealers and Radio Parts Jobbers... or write for latest, free Catalogue.

REK-O-KUT CO.

38-01 Queens Blvd., Long Island City, N. Y.

EXPORT BRITISH: 458 Broadway, New York City, U. S. A.
CANADA: 4115 KENNEDY ST., TORONTO, ONT., CANADA

Air-Tone

HEADQUARTERS FOR SOUND EQUIPMENT

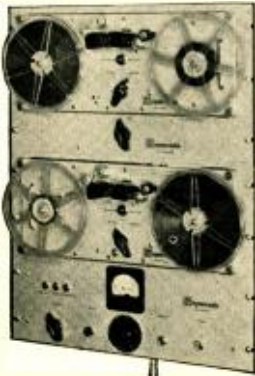

**MAGNECORD
RECORDER & AMPLIFIER**
Complete Systems from \$564.00



**NEWCOMB
AMPLIFIER**
Complete line of High Quality Amplifiers,
from small single units to large rack
installations



ELECTRO-VOICE SPEAKERS
From \$27.00 to \$756.00 NET

Air-Tone
SOUND AND RECORDING CO.
1527 CHESTNUT ST.
PHILA. 2, PA. • RI-6-8388



AUDIO PATENTS

RICHARD H. DORF*

THERE ARE MANY occasions for using high-impedance sound transducers in which conversion to low impedance would be a hardship, but where the cable between transducer and amplifier must be long enough to attenuate to the higher frequencies considerably. A typical example is a motion-picture-projector phototube, in which the preamplifier must ordinarily be very close to the projector to avoid loss of treble.

Louis L. Pourciau of Pleasantville, N. Y., has invented an amplifier circuit which is capable of removing this handicap completely and allowing a very long line without any drop in highs. His patent, assigned to General Precision Laboratory, Inc., is No. 2,559,515. The schematic diagram appears in Fig. 1.

The dropoff in highs in the usual case is caused, of course, by the capacitance between the inner conductor of the cable and the shield (or other wire). The capacitance tends to shunt highs, the effect increasing with both increasing frequency and cable length.

Mr. Pourciau employs two simultaneous methods of cancelling the bad effects. In considering the first, let us ignore the fact that Fig. 1 shows the cable between the photocell and the amplifier as having two shields—let us consider only a single-conductor, shielded line.

The input stage V_1 is a resistance-coupled triode with its cathode connected to the cathode of V_2 , thence to ground through R_1 . The plate of V_1 is coupled to the grid of V_2 , a second resistance-coupled triode (with an unbypassed cathode for better linearity), and the plate of V_2 is coupled to the grid of V_3 . Because V_1 and V_2 are alternate stages, the cathode currents of the two tend to reinforce. Thus, when the instantaneous signal applied to

the V_1 grid is positive, the V_1 plate and V_2 grid are negative and the V_2 plate and V_3 grid are positive. The cathodes of both V_2 and V_3 are also positive, but the cathode of V_1 is much more positive than it would be if it were simply connected to ground through its own resistor. The entire arrangement constitutes a high-gain inverse feedback loop, since the action of the V_2 plate current in making the cathode of V_1 more positive makes the grid more negative to oppose the original positive input signal.

Under these conditions the cathode potential of V_1 approaches the ideal predicted for a cathode follower with an infinite load resistance. This potential, determined only by the μ of V_1 , is $\mu(\mu+1)$.

The result is that the voltages appearing at the grid and cathode of V_1 are almost identical. As the diagram shows, the inner shield of the connecting cable is connected to the cathode of V_1 rather than to ground. With the conductor and the cathode at practically the same potential, the effects of shunt capacitance are very greatly reduced and the gain-frequency curve is much improved.

The second improvement, which results in a perfectly flat characteristic, and may in fact result in a rise of highs with increasing cable length if that is desirable, comes from the use of a second shield placed over the first and insulated from it. This creates capacitance between the two shields, the total value of the equivalent capacitor depending on the cable length. The outer shield is connected to ground, so that the capacitance appears across cathode resistor R_1 (dashed lines). The degree of feedback depends on the cathode load impedance, which now becomes less with rising frequency. The result is decreasing negative feedback with rising frequency and a consequent rise in amplifier gain which compensates for the treble dropoff.

Signal for the output stage V_4 , which is

[Continued on page 4]

* Audio Consultant, 255 West 84th St., New York 24, N. Y.

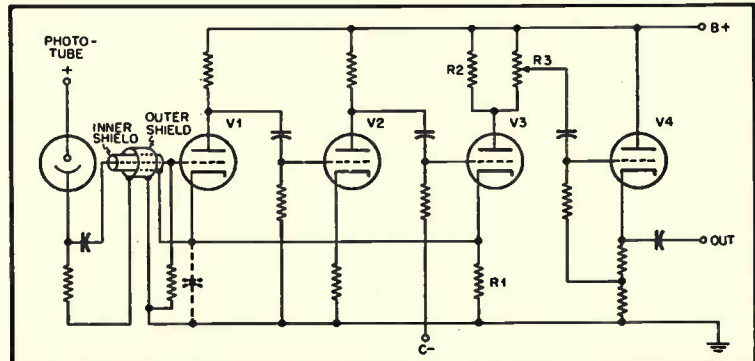

Fig. 1



IT'S UNOBTUSIVE. Umber gray coloring blends it right into the TV picture. Minimum reflection.



In the show . . .
 without stealing the act
 RCA's new ribbon-pressure **"STARMAKER"***

SO SLIM YOU MUST LOOK sharply to see it . . . so skillfully styled its shape and coloring fade right into the scene . . . this tubular microphone has won the favor of entertainers and announcers wherever it has been shown.

Designed by RCA Laboratories after more than three years of painstaking research, the STARMAKER meets the long need of broadcasting, television, and show business for a high-fidelity microphone that—will not hide the features of performers—is easier to handle—and yet retains all the high-quality features of RCA professional microphones. Pick-up is non-directional. Frequency response is uniform, 50 to 15,000 cps.

Here is a "carry-around" microphone free from wind blast and air rumble. It contains no tubes, no condensers, no high-impedance circuits, no special amplifiers, or power supplies—is virtually impervious to mechanical shock.

The STARMAKER fits any standard microphone stand . . . and can be substituted for any professional high-quality RCA microphone. *No extra attachments needed!*

For price and delivery, call your RCA Broadcast Sales Engineer. Or write Dept. 16A, RCA Engineering Products, Camden, N. J.

**Selected from entries submitted by Broadcast Stations in national contest.*



IT'S COMFORTABLE TO HANDLE . . . weighs only 1 lb.



IT'S SMALL. Diameter of body is only 1¼ inches. Diameter of pick-up point is only ⅜ inch!



AUDIO BROADCAST EQUIPMENT
RADIO CORPORATION of AMERICA
ENGINEERING PRODUCTS DEPARTMENT, CAMDEN, N. J.

In Canada: RCA VICTOR Company Limited, Montreal



Balanced tone

... from the flashing sunlight
of Mozart to the storm of
Shostakovich

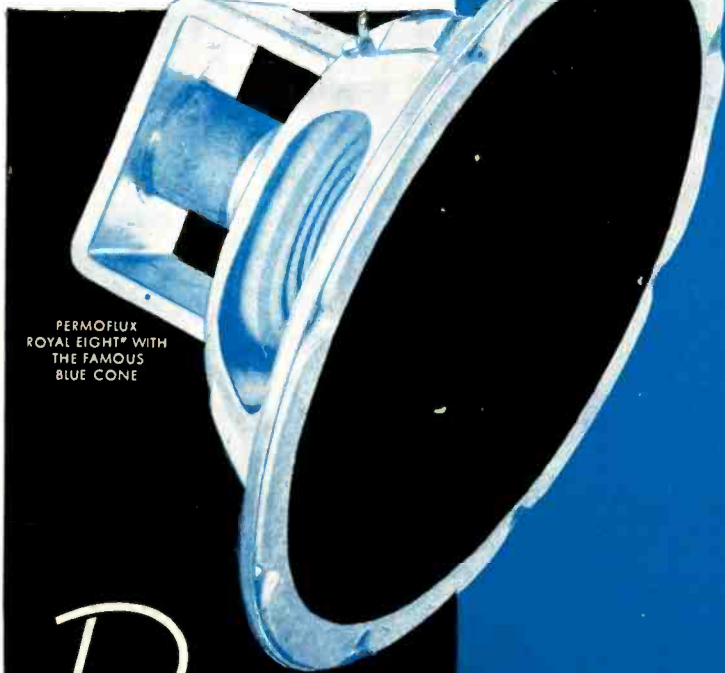

PERMOFLUX
ROYAL EIGHT™ WITH
THE FAMOUS
BLUE CONE

Permoflux ROYAL EIGHT™

AUDIOPHILES the country over acclaim the clean, brilliant, life-like musical reproduction of the Permoflux Royal Eight™... the 8" Speaker comparable to any 12"! Combined with the new Permoflux Corner Baffle, Model CB-8-M, the Royal Eight™ re-creates original programs with even superior sensitivity and fidelity—every instrument in full-range tonal balance. Here's Big Speaker Performance in a small, easy-to-install frame at a sensible price. (\$22.50 List, less Baffle).

See your Radio Parts Distributor or write to Permoflux today for full information about the complete Royal Blue Line of 6" to 15" Speakers and Baffle Combinations. Ask for Permoflux Catalog J-202.

"Sound in Design!... Sound in Price!"

PERMOFLUX CORPORATION 4902-AW, GRAND AVE., CHICAGO 39, ILL.
236 S. VERDUGO RD., GLENDALE 5, CALIF.

Canadian Licensee—Campbell Mfg. Company, Toronto, Canada

a cathode follower for convenient coupling to the power amplifier, is obtained from the load resistor R_L across the plate of V_1 and the volume-control potentiometer R_v in shunt with R_L .

(Note similarity to equipment described by C. J. LeBel in "New developments in cathode followers," *AUDIO ENGINEERING*, Aug. 1949, Ed.)

Inexpensive Bypassing

The ordinary pentode voltage-amplifier stage runs into expense—and, what is more important, takes up considerable room—if it is to be adequately bypassed to allow very-low-frequency reproduction without objectionable attenuation or phase shift. For example, the typical pentode stage of Fig. 2, with its 50- μ f cathode and 1- μ f screen bypasses may have a gain at 20 cps of only 60 per cent of midband and a 35-deg. phase shift.

Howard M. Zeidler of Palo Alto, Calif., has invented the circuit of Fig. 3. The patent is numbered 2,566,508, and is assigned

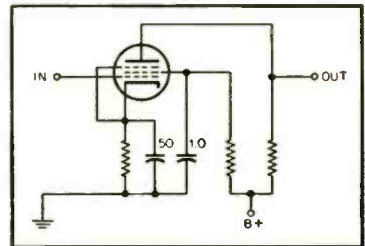

Fig. 2

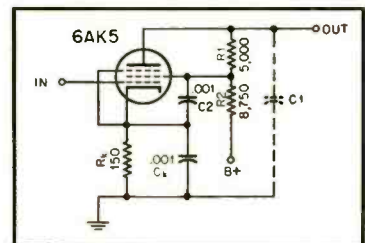

Fig. 3

to Hewlett-Packard. An essential part of the circuit is the method of calculating the components, for which the reader is referred to the patent, available like all others from the Commissioner of Patents, Washington 25, D. C., for 25¢. Note, however, that the two capacitors are very small and make it possible for the entire stage to be placed in small space. In spite of this there is no phase shift nor loss of gain at all at low frequencies. The values shown are typical ones, giving the network a gain of 26 db and response flat to about 2 mc, the upper limit depending on the total of the output capacitance of the stage and the input capacitance of the next stage (shown as a single equivalent capacitance C_1). The limit for low frequencies is only the blocking capacitor between stages.

At high frequencies C_1 is effectively a short between screen and cathode, eliminating screen and cathode degeneration so that the gain is that of an ordinary pentode and the plate load is R_L . At low frequencies C_2 is effectively an open circuit and there are two simultaneous effects. First, the un-bypassed cathode and screen introduce degeneration. But this is offset by the fact that the plate load becomes the sum of R_L

[Continued on page 35]

**CUT CORES
SQUARE
RECTANGULAR
TOROIDAL**

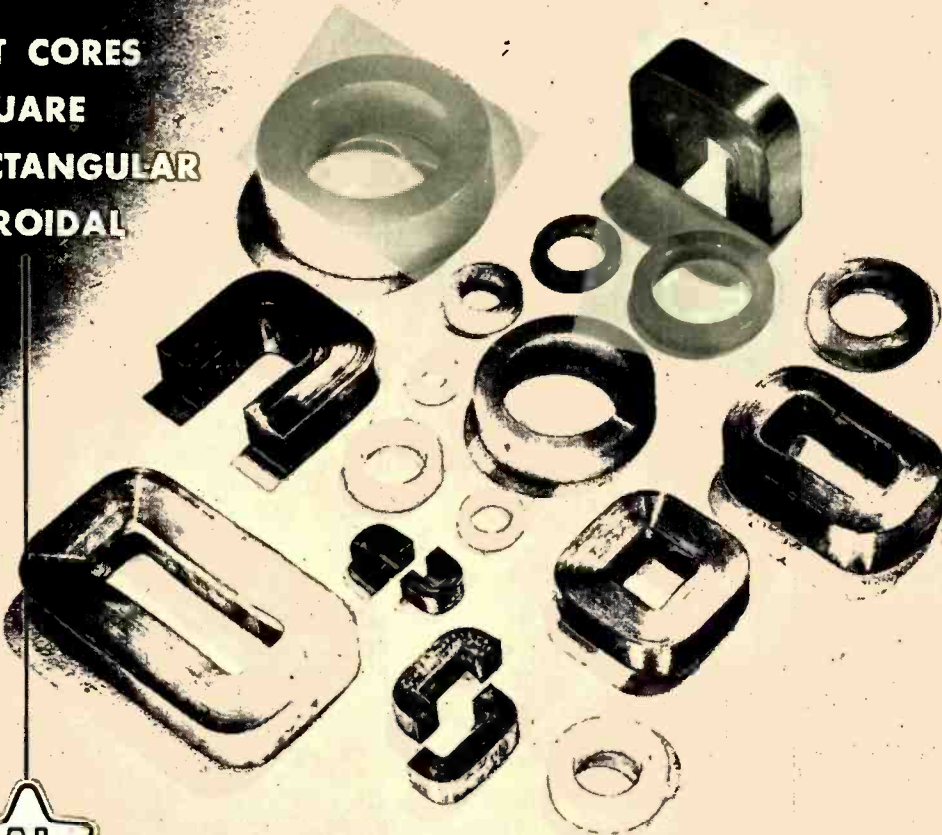

Anything You May Need in **TAPE-WOUND CORES**

RANGE OF MATERIALS

Depending upon the specific properties required by the application, Arnold Tape-Wound Cores are available made of DELTAMAX . . . 4-79 MO-PERMALLOY . . . SUPERMALLOY . . . MUMETAL . . . 4750 ELECTRICAL METAL . . . or SELECTRON (grain-oriented silicon steel).

RANGE OF SIZES

Practically any size Tape-Wound Core can be supplied, from a fraction of a gram to several hundred pounds in weight. Toroidal cores are available in fifteen standard sizes with protective nylon cases. Special sizes of toroidal cores—and all cut cores, square or rectangular

cores—are manufactured to meet your individual requirements.

RANGE OF TYPES

In each of the magnetic materials named, Arnold Tape-Wound Cores are produced in the following standard tape thicknesses: .012", .008", .004", .002", .001", .0005", or .00025", as required.

Applications

MAGNETIC AMPLIFIERS
PULSE TRANSFORMERS
CURRENT TRANSFORMERS
WIDE-BAND TRANSFORMERS
NON-LINEAR RETARD COILS
PEAKING STRIPS . . . REACTORS.

W&D 3983

THE ARNOLD ENGINEERING COMPANY

SUBSIDIARY OF ALLEGHENY LUDLUM STEEL CORPORATION
General Office & Plant: Marengo, Illinois

There's a **NEW SILHOUETTE**
on the Microphone Horizon...

THE NEW
**ULTRA-CARDIOID
DYNAMIC**

MODEL **55s**

"THE PERFECT PERFORMER"

SMALL
Unidyne



MODEL 55-S
List Price \$72.50

The New Small Unidyne is
approximately only half as large as
the Standard Unidyne.

► Eliminates Feedback Problems

► Permits performer to stand
farther from the microphone

THIS MIGHTY, though little, Microphone, is the *only* small-size, uni-directional moving-coil dynamic microphone—all the important directional qualities are retained. The 55-S is actually a new Microphone retaining all the highly desirable features that made the Model 55 "Unidyne" world-famous.

Model 55-S offers superior performance, featured in a streamlined, small, functionally-designed case. The moving-coil system has a high overall efficiency and smooth frequency response. A large air-gap clearance and a rugged coil construction provide immunity to abnormal atmospheric conditions and severe mechanical shocks.



Model 55-S
Small
Unidyne

Model 556-S
Small
Broadcast
Dynamic

Model 55-S Small Unidyne
Model 556-S Small Broadcast

Code: RU DOT List Price: \$72.50
Code: RU DOV List Price: 100.00

Patented by Shure Brothers, Inc.



SHURE BROTHERS, Inc. ★

MANUFACTURERS OF MICROPHONES
AND ACOUSTIC DEVICES

225 W. Huron St., Chicago 10, Illinois

● Cable Address: SHUREMICRO

LETTERS

Pocket FM Receiver?

Sir:

... Would like to know if any of your experimenters have ever built a miniature FM radio that could be operated with hearing-aid batteries and that could be used with receivers such as those used with hearing aids. Do you know of any such radio on the market?

T. W. States,
P. O. Box 303,
Gastonia, N. C.

(To the first question: we know of none, but maybe they've kept it a secret. To the second question: we know of none. E.D.)

English Audio—Version III

Sir:

... The article (*Audio in England, E., Oct. 1951*) appears to be based on an inspection of the recent National Radio and Television Exhibition in London, but your correspondent must have been aware that a large proportion of firms specializing in high-quality recording and reproduction were not exhibiting at this Show, which appeals more to the general public than to the discriminating audio enthusiast.

Nevertheless, it was apparently not known to your correspondent (though the fact was mentioned in the exhibition catalogue and elsewhere) that concurrently with the exhibition and in a hall in the same building, this Institution held a three-day Convention solely devoted to audio engineering. Some fifteen papers were read and discussed, dealing with all aspects of British developments in this field, and much advanced equipment was demonstrated.

The main purpose of this letter is to state that in the view of this Institution your correspondent's comments will undoubtedly create an entirely wrong impression of the present state of audio engineering in this country. This as you must realise, cannot be judged by a superficial glance round a general exhibition of domestic radio and television.

W. E. Miller, Vice-Pres.
The British Institution
of Radio Engineers,
9 Bedford Square,
London W.C.1, England.

Version IV

Sir:

... We appreciate that you have no definite means of ensuring that articles submitted from persons in the United Kingdom do, in fact, convey the correct impression of the subject matter in question, and it is here that we may perhaps be able to offer our assistance in the future by submitting, should you so desire, several names of competent audio and recording engineers who may be willing to provide articles and news pertaining to those subjects, as they exist in this country, in order that you may approach them on the occasions when you feel that such articles would be desirable...

Richard W. Lowden, Hon. Sec'y.
British Sound Recording Assn.,
Wayford, Napoleon Avenue,
Farnborough, Hants., England

[Continued on page 8]



HUDSON has the RIGHT COMBINATION for Your Complete HI-FI Satisfaction!

- ALL FAMOUS HIGH FIDELITY EQUIPMENT IN STOCK
- NEWEST, PUSH BUTTON AUDIO-COMPARISON SOUND STUDIOS
- EXPERT TECHNICAL ASSISTANCE
- LOWEST POSSIBLE PRICES

The Only True High Fidelity—High Performance Tape Recorder in the Popular Price Field!

FAMOUS Concertone TAPE RECORDER

By Any Standard of Comparison It Is The Best Buy in the Tape Recorder Field!



The Concertone meets all professional requirements, yet is priced Exceptionally Low! Equalization conforms to NAB Recommended Broadcast Standards. Extended Frequency Response is 50 to 15,000 cps \pm 2 db at 15" per second speed. Tape Noise down to random level. Also has 7.5" per sec. Speed. Pre-aligned heads quickly interchangeable for

Dual or Single Track Recording. Total Harmonic Distortion less than 2% at normal maximum signal level. Has 3 dynamically balanced motors, separate heads for recording, erase, and playback. Simultaneous monitoring from tape while recording. Instant choice of 7.5" or 15" per second speeds. Fast Forward, Rewind, and Reverse (2500 ft. per min.). All controls are interlocked to prevent spillage or tearing of tape. Size of basic recorder: 22 x 14 x 5" mtg. depth below panel. Use with any good quality amplifier.

AVAILABLE AS BASIC UNIT WITH CARRYING CASE OR CONSOLE CABINET
BASIC RECORDER, 1401D: Drive mechanism, power supply, erase, record, and playback preamplifiers, mounted on base plate, ready for installation. With Dual Track Heads. No. A16147, Net **\$345.00**
 Model 1401S, same with Single Track Heads, Net \$345.00

ELECTRO-VOICE



Model SP15
 RADAX
 SUPER
 FIFTEEN

For the discriminating high fidelity enthusiast, and broadcast monitoring. Deluxe coaxial two-way speaker system employs special 125 sq. in. bass cone for efficient, extended low-frequency reproduction. Bass cone is seamless, molded type—treated against moisture and fungus. 2 1/2" aluminum voice coil directly coupled to "Whizzer" cone for maximum high frequency response. Small size of high frequency propagator insures full dispersion through solid angle of 100° and extends treble range two full octaves. Rated 30 watts program material. Impedance, 16 ohms. Response in proper enclosure, 30-16,000 cps. flat \pm 5 db. Bass cone free space resonance, 38 cps. 5 1/4" lb. Alnico V magnet. Crossover, 3000 cps. Diameter, 15 1/8" x 8 7/8" deep. Shpg. wt., 35 lbs.

No. A30353, List, \$120.00.....NET PRICE **\$70.56**

Amazing Performance! Truly Sensational Value!

Exclusive at HUDSON

audio-pacific

TRUE HIGH FIDELITY AMPLIFIERS

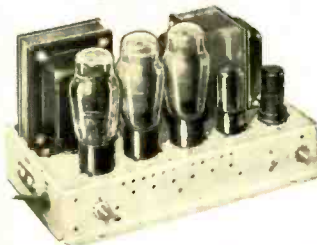

MODEL 4 LH—The basic amplifier of medium gain for use with tuners and as studio monitors, etc. Expressly designed for tuners incorporating bass and treble controls and pre-amplifier stage for phono. Tube complement, 1-6J5, 1-6SN7, 2-6L6G, 1-5U4. Size 7" W x 8" H x 11" L. Net price **\$64.00**

Starting Performance at a price everyone can afford! These famous amplifiers give a new concept to the phrase Hi-Fidelity. They have been rated "Superb" by sound engineers who know!

Leading consumer research organizations have found them very conservatively rated! The frequency response is from 18 to well beyond 20,000 cycles within .1 Db. Presence effect is truly astounding, reproduction is rich, brilliant and crisp. Noise, hum and harmonic distortion have been reduced to the vanishing point, — 85 Db. below 20 watts.

Harmonic distortion is only 1/2% at 19.6 watts (40 watts peak), with 40 Db feed back. Hum, and noise measure less than 1 milli-volt across a 10 ohm load.

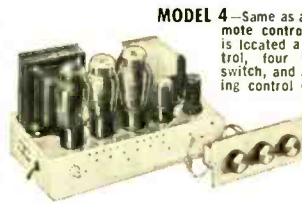

MODEL 4—Same as above with with remote control panel on which is located a master level control, four position selector switch, and a low level listening control designed to allow full round, rich tone at whisper levels. Tube complement 1-6J5, 1-6SN7, 2-6L6G, 1-5U4. Size as above.

Net price **\$68.00**



MODEL 3—Same as 4 LH but with an additional 1-6J5 for the bass and treble boost controls which are incorporated. Size same as Model 4 LH. Net price **\$85.00**

STEPHENS COAXIAL SPEAKERS



MODEL 106AX 15" COAXIAL SPEAKER. For use in installations where a very high degree of audio fidelity is required in reproduction of both voice and music. Ideal for deluxe custom installations, broadcast and FM station monitoring and motion picture sound reproduction. Meets the most exacting requirements. Has power handling capacity of 20 watts.

Employs type "LX" 15" cone for frequencies below 1,200 cycles and a high frequency driver with multicellular horn for the range above 1,200 cycles. Supplied with built-in frequency dividing network.

Clean, distinct bass response is provided by low frequency resonance of 41 cycles, and exceptionally large Alnico V magnet (6 1/2 pounds). Uniform distribution of high frequencies over a large area is assured by extremely wide dispersion angle of 40° x 80°. Frequency response, \pm 5 db from 35 to 12,000 cycles. Usable range extends from 20 to 15,000 cycles. Voice coil impedance, 16 ohms. Diameter, 15 1/8"; baffle opening, 13 1/2"; depth, 10 1/2". Shpg. wt., 30 lbs.

No. A20310, List, \$166.00.....NET PRICE **\$122.01**

FAMOUS COLLINS HI-FI TUNERS

High Fidelity At Its Best! All the technical skill and craftsmanship possible have been incorporated into Collins Audio Products. As a result these units closely approach custom-built quality, which is apparent upon inspection and demonstration.

COLLINS FM-11 FM TUNER. Surpasses the performance of any unit in its price class. 9 miniature tubes, plus tuning eye and rectifier. 19 1/4 x 12 x 7 1/4.

No. A3001.....NET PRICE **\$59.50**

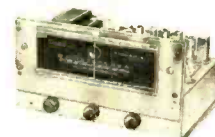

WE STOCK AND DEMONSTRATE ALL STANDARD MAKES OF ELECTRONIC AND AUDIO EQUIPMENT

REVOLUTIONARY NEW SOUND STUDIOS!

Our uptown store features the most advanced installation anywhere! Relax in an easy chair... select and operate ANY combination of world famous high fidelity components by PUSH-BUTTON Remote Controls. Every music lover, engineer, sound technician and high fidelity enthusiast will be fascinated by this new ingenious approach to audio-comparison. Sound studios at Both Stores.

UPTOWN:
 48 West 48th St., New York 19, N. Y.

DOWNTOWN:
 212 Fulton Street, New York 7, N. Y.

PHONE: Circle 6-4060

HUDSON

RADIO & TELEVISION CORP.

Formerly Newark Electric Co., Inc. of New York

For a Glorious

BIG TONE

ON ANY STRINGED INSTRUMENT

specify the Genuine

AMPERITE "KONTAK MIKE"

THE ONLY NO-DISTORTION "KONTAK MIKE"

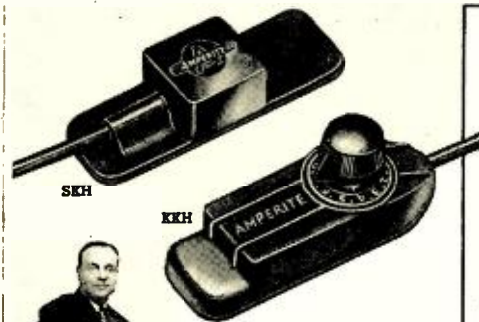

Anthony Antone, widely known as "the most versatile artist of the frets", is an enthusiastic user of Amperite Kontak Mikes.

Used with most amplifiers, including most electric guitar amps.

No changes in amplifier, instrument, or strings. Attached without tools.

The Amperite "Kontak Mike" improves the tone and volume of any Stringed or Fretted Instrument — also Pianos, Accordions, Harmonicas, etc. It is the only "Kontak Mike" that does not introduce peaks or distortion.

Model SKH, hi-imp List \$12.00
Model KKH

(with hand volume control) List \$18.00

AMPERITE STUDIO MICROPHONES at P. A. PRICES!

Ideal for CLOSE TALKING
or DISTANT PICKUP

You can shout right into it, or stand away; in either case, the quality will be perfectly natural.

Model RBLG (200 ohms) List \$42.00
Model RBHG (hi-imp) List \$42.00

AMPERITE CARDIOID
DYNAMIC MICROPHONE
Models PGH-PGL List \$32.00



SPECIAL OFFER:
Write for Introductory
Offer, and 4-page
Microphone Folder 53-M.

AMPERITE Company, Inc.

561 Broadway • New York 12, N. Y.

In Canada: Atlas Radio Corp., Ltd., 560 King St., W., Toronto 28

Version V—Last Rebuttal

Sir:

... Now come orf it Mr. Artley, why so despondent? There's good and bad in the best of us, and there's no sense in telling our American friends only the bad and distorting the facts in addition. . . .

M. M. Freeland,
P. O. Box 3002,
Singapore, Malaya

Theremin Builders, Attention!

Sir:

I would appreciate any information you have or can direct me to on the construction of a Theremin. I want to build or buy one, but there doesn't seem to be any recent information on a model using the late tube types.

Dell F. Allen,
Route 4, Box 123,
Aurora, Colo.

(We take this means of passing Mr. Allen's request on. Any volunteers? Ed.)

Custom Installations

Sir:

I was a former subscriber, but the articles got so uninteresting I failed to renew. It's surprising, though; there is always something of interest in the magazine, and I found myself buying it each month. I missed out on the November issue, and got irked enough to resubscribe. I would hate to miss a good article now and then on amplifiers and preamps. I do feel, though, that the field of custom installations and speaker enclosures has not been covered very completely. . . .

Nathan M. Garfinkle,
141 Greenway Drive,
Walnut Creek, Calif.

(We agree with your last sentence. Commencing in this issue, and continuing every month, is a series by William Shrader—one of the most successful custom builders in the country—on just that subject. We anticipate the answer to your wishes in Mr. Shrader's department. Ed.)

Too Scientific

Sir:

Just received my December issue and was much interested in the LETTERS section. I heartily second Morgan Kennedy's request for more butter on the popcorn. Originally I found Æ palatable because of the wealth of sound detail on speaker systems, etc. that enabled me to fabricate my own home music combination. However, during the past four months or so, Æ's menu has become steadily more indigestible due to the inclusion of mathematical data more suitable to the journal of a scientific society.

The article on the R-J speaker enclosure sounds appetizing, but I don't think it will set really well until you publish a subsequent description of the box with all dimensions included. You might even garnish it with a practical discussion of woodworking techniques.

I think it unfair to allow Canby to whet our appetites by tantalizing tidbits tossed into our musical maw like a fish being thrown to a seal, then to deny us full realization of the main course. We've had the appetizer; just serve the main course and forget the dessert.

Jerome S. Miller,
1338 Washtenaw,
Ann Arbor, Mich.

(Messrs. R-J promise us constructional details as soon as they can release the information—about three months, we'd guess. Ed.)

Be Sure of Your Installations Get the *Aptitude-Tested* RG/U TRANSMISSION LINE CABLES

● You know what you are doing when you use Belden RG/U Transmission Line Cables—they're aptitude rated. They are designed to provide desirable electrical characteristics, and rigid control assures constant quality.

Specify Belden Radio Wires.

Belden Manufacturing Co.
4689-R W. Van Buren Street
Chicago 44, Illinois

APTITUDE RATING No. 8236		APTITUDE RATING No. 8237		APTITUDE RATING No. 8238		APTITUDE RATING No. 8239		APTITUDE RATING No. 8241		APTITUDE RATING No. 8240	
Frequency (Mc)	Attenuation per 100 ft	Frequency (Mc)	Attenuation per 100 ft	Frequency (Mc)	Attenuation per 100 ft	Frequency (Mc)	Attenuation per 100 ft	Frequency (Mc)	Attenuation per 100 ft	Frequency (Mc)	Attenuation per 100 ft
100.	2.65	100.	2.10	100.	1.90	100.	2.90	100.	3.75	100.	4.10
200.	3.85	200.	3.30	200.	2.85	200.	4.20	200.	5.60	200.	6.20
300.	4.80	300.	4.10	300.	3.60	300.	5.50	300.	7.10	300.	8.00
400.	5.60	400.	4.50	400.	4.35	400.	6.70	400.	8.30	400.	9.50



Belden
Radio WIRE

The
Aptitude-Tested **LINE**

EDITOR'S REPORT

THE NEW YEAR

EVERY TWELVE MONTHS at just about this time, most of us are constrained to make a number of resolutions which we may or may not intend to keep—depending upon how much these resolutions encroach upon our personal liberties. Similarly, most publications take this opportunity to make boasts, claims, excuses, or promises with—in many cases, apparently—tongue in cheek, just as we individuals have. There is one difference, however. Most of our personal resolutions are purely oral, and therefore subject to various interpretations depending upon the memory or upon the particular temptation which threatens to breach our good intentions. But when a magazine makes resolutions, it does so by causing them to be printed, and they become a matter of record. Once set down in black and white, these resolutions remain to plague editors and publishers, subject to finger-pointing and such humiliating actions of subscribers, advertisers, and casual readers alike. May we be spared the ordeal of pointed fingers.

Æ is approaching the end of five years of pioneering a field in which there had been a dearth of technical literature. The field is even larger than we have been able to cover thoroughly, and many readers constantly ask for things we haven't yet got around to. For example, literally hundreds of readers maintain that we are too technical—that they try to understand all the articles, but that some are beyond their comprehension. That is not unexpected. Occasionally we pick up a magazine which is—to use a colloquialism—pure Greek to us. We are not familiar with the terms or the symbols employed, and in many cases, with the words used in the body of the text. We have two choices—we can either learn the words, terms, and symbols, or we can continue to remain ignorant in that field. No one seems willing to enlighten us.

Æ is not of that opinion, however, and is willing to try to enlighten the non-professional reader. Æ is going to try to cover more of the field, and in addition is going to introduce an innovation. Suppose, for example, that the article by Toth (p. 13) were read by a layman. He might not understand what it was all about. All right—in the section dubbed Audio-in-the-Home, this same layman can read a condensation of the same article in plain ordinary English. In simple, non-technical terms, he will be told what the article intends to say, its importance to the listener, and the conclusions arrived at. Since the Toth article is in two parts, this new experiment will start next month, but we'll give it a try. And, of course, we'll welcome comments. Which we'll probably get—both pro and con.

Audio-in-the-Home is intended for the person who wants better sound—practically everyone knows by now that it's possible to have it—from radio or records, and who is disinclined to construct an amplifier, a tuner, or any other piece of electronic apparatus. Many of us would rather build equipment than buy it, but we must

admit that it is usually less expensive in the long run to buy an amplifier than it is to build one. That still does not deter us confirmed hobbyists, and we'll still chop holes in chassis and wire up the circuits that someone proposes or that we ourselves design. It's fun both ways—whether we build from scratch or assemble ready-built components. The results justify the time and money expended in either case. Recognizing both types of reader, Æ now takes the step slightly sidewise and brings the lay reader some “butter on his popcorn,” as one reader so aptly expressed it in last month's LETTERS.

ANOTHER INNOVATION

For the photographically inclined we are trying, mildly, another innovation. The double photographs on pages 20 and 21 are not a mistake—they are stereo pairs. With a little practice, you can spread your eyes apart and see them as three-dimensional photos; until you have the practice, you may find it easier to hold a piece of cardboard perpendicular to the page at the dividing line, viewing each photo with but one eye. Try it and see.

We believe that free-vision stereo pictures will lend a new meaning to pictures of chassis, or of whole installations of equipment—both for the home and for professional applications. We will, therefore, accept stereo photos with any future articles if they show more than single pictures do.

Photographic magazines please copy.

REITERATION

For the rest, we shall continue to bring the new circuits, improvements in equipment, developments in the art, and all else in the field of audio—making Æ stand for Audio Everywhere as well as for the more familiar AUDIO ENGINEERING. We shall continue to strive to make every article reliable—as we believe we have in the past. That every circuit presented in these pages should be workable is our foremost precept. That we sometimes do not have room for more articles is regrettable—we could resort to much smaller type, but most readers would not approve of that approach. So, the more we grow, the more articles we can carry, and magazines—like people—generally grow larger with the years.

MISSING CREDIT

Mr. Aubry's article on Intermodulation Testing, in the December issue, described an instrument which he had built and used, and outlined the kind of information which could be obtained by the use of such an instrument. Since the design of the generator and analyzer was so obviously similar to that described by John M. van Beuren in the November 1950 issue, credit for the original circuit arrangement should have been included. Mr. van Beuren's design is commercially available, and we take this means to give credit where credit is due.

MAURER... AT HOME ANYWHERE

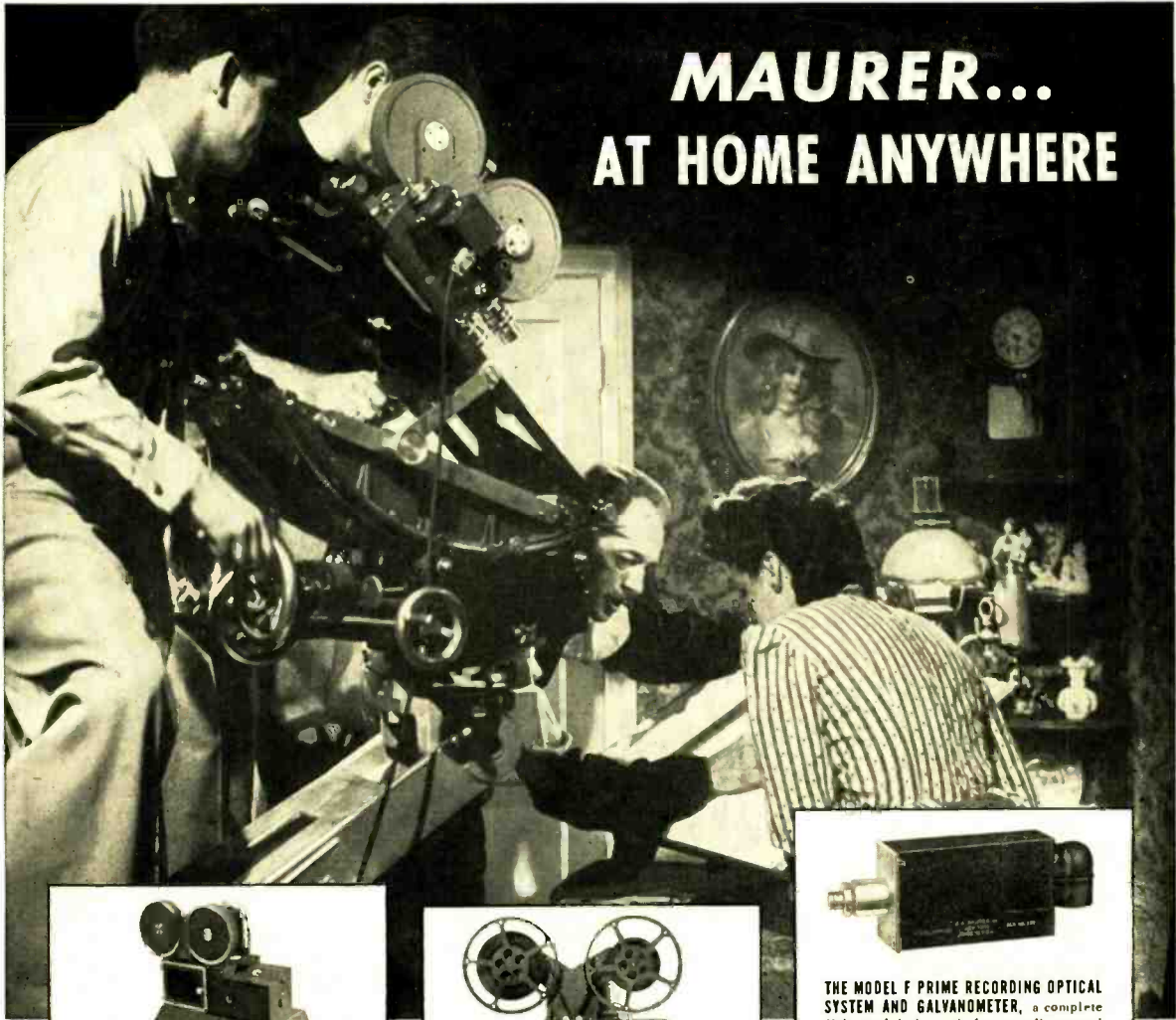

THE 16MM. SOUND-ON-FILM RECORDING SYSTEM. Capable of recording either negative or direct positive variable area and variable density sound tracks.



THE 16MM. FILM PHONOGRAPH. Unique optical system gives an unusually narrow reproducing image with high light output.



THE MODEL F PRIME RECORDING OPTICAL SYSTEM AND GALVANOMETER, a complete light modulating unit for recording sound photographically upon standard film.



THE MAURER 16MM. CAMERA. Equipped with unique precision high-power focusing. Equipment includes: 235 ϕ dissolving shutter, automatic fade control, viewfinder, sunshade and filter holder, one 500-foot gear-driven film magazine, a 60-cycle 115-volt synchronous motor, one 8-frame handcrank, power cable and a lightweight carrying case.

The Maurer 16mm. camera is at home for every professional requirement—and little wonder since it's the only "16" specifically designed for professional use. The Maurer has many unique features—its simplified operation, hair-line accuracy, and job after job dependability, all make it the favorite choice of those who consider time and expense important—and a fine motion picture even more so.

For details on this and other Maurer equipment write:

J. A. MAURER, INC.

37-01 31st Street, Long Island City 1, New York
1107 South Robertson Blvd., Los Angeles 35, California

**16mm
maurer**

CABLE ADDRESS:
JAMAURER



Each crystal is enclosed in a cylindrical oven which holds the crystal temperature to within 1/100 of a degree.

At the A. T. & T. building at 195 Broadway, New York, passersby set watches by the world's most accurate public clock, which is controlled by the master standard.

↑ Front of the new frequency-time standard at Bell Telephone Laboratories. In the rear there are 600 electron tubes and 25,000 soldered connections. Room temperature is maintained within two degrees.



The controlling quartz crystal vibrates in vacuum at 100,000 cycles per second. The standard is powered by storage batteries, with steam turbo-generator standing by, just in case of emergency.

A vibrating crystal keeps master time

Ever since Galileo watched a lamp swinging in the Cathedral of Pisa three centuries ago, steady vibration has provided the practical measure of time. In the 1920s Bell Laboratories physicists proved that the quartz crystal oscillators they had developed to control electrical vibration frequency in your telephone system could pace out time more accurately than ever before.

The Laboratories' latest master standard keeps an electric current vibrating at a frequency that varies only one part in a billion, keeping time to one ten-thousandth second a day.

Through secondary standards, a master oscillator governs the carrier

frequencies of the Bell System's ship-to-shore, overseas and mobile radio-telephone services, the coaxial and *Radio-Relay* systems which transmit hundreds of simultaneous conversations, or television. In the northeastern states, it keeps electric clocks on time through check signals supplied to electric light and power companies.

The new standard also provides an independent reference for time measurements made by the U. S. Naval Observatory and the National Bureau of Standards. Thus, world science benefits from a Laboratories development originally aimed at producing more and better telephone service.

BELL TELEPHONE LABORATORIES



Improving telephone service for America provides careers for creative men in scientific and technical fields.

The Design of Compensated Volume Controls

EMERICK TOTH*

Part I. A study of the psychoacoustic considerations involved in designing a control which is practical in construction and adequate in performance.

THE REPRODUCTION OF SOUND, like the photographic reproduction of scenes in picture form, usually poses a problem of accurate representation in miniature. Through preference, or by force of circumstance, the general public who foots the bill for most radio and phonographic sound is normally interested in a rather low level of average maximum sound intensity.

Listener Preferences

Figure 1 shows the preferred values derived from a recent study of a large group of listeners.¹ In this graph, the connecting lines between points serve only to distinguish between the groups tested. It is interesting to note that, according to this information, Mr. and Mrs. Public do not care to hear symphonic music reproduced at a higher average level than about 78 decibels, while engineers and musicians seem to like having their eardrums battered at 87 to 90 db average. If it's music of any kind, the engineer likes it good and loud, whereas the musician seems willing to turn down the volume control if it isn't "classical," and will then listen at levels not too far from those favored by the general public.

It is evident, from the relative scale of power shown in the graph, that many engineers and some musicians will be good prospects for amplifiers and loudspeakers capable of delivering about 10 times as much power output as will satisfy the ordinary customer. It also appears that disregarding that rugged individualist—the program engineer—the region of 80 to 83 db intensity or sound pressure will be a reasonable compromise as a sort of standard median level for much of the music people listen to. The average sound pressure level of a 75-piece orchestra at 15 feet is of the order of 85 db. Apparently the ordinary listener does not like to get closer than the equivalent of a distance of about 40 or 50 feet, at least with reproduced sound, while the musician and engineer want front seats at the symphony. The graph indicates that most people are satisfied to have speech levels about 4

* Radio Techniques Branch, Radio Division II, Naval Research Laboratory, Washington, D. C.

¹ Derived from data on listener preferences; Somerville and Brownless, *BBC Quarterly*, January, 1949.

to 6 db below their preferred values for light concert and dance music. Current American broadcast practice appears to provide about such a difference for announcements between musical numbers.

Listening Levels

An average maximum level of 80 db for music may not be tolerated very amiably in most households, particularly when it is considered that peaks of sound may then reach subway train noise levels (100 db) or higher. In many cases, the listener may be constrained to get what musical enjoyment he can out of symphonic orchestra or opera reproduction at average maximum sound pressure levels as low as 50 or 60 db, with peaks reaching about 70 or 80 db. It will, of course, be no difficult problem to turn the volume down 20 or 30 decibels below 80 db average, even though it may be a sacrifice. This, however, will not miniaturize the music uniformly in all registers unless special compensating circuits are provided. A decrease of, for instance, 20 db in sound pressure will not produce 20 db decrease of loudness sensation in the listener's mind, even at 1000 cps, except in some one particular range of sound pressures.²

² Derived from curves of 1000-cps loudness vs. loudness level, and from contour lines of equal loudness; Fletcher and Munson, *J. Acous. Soc. Am.*, 1933 and 1937.

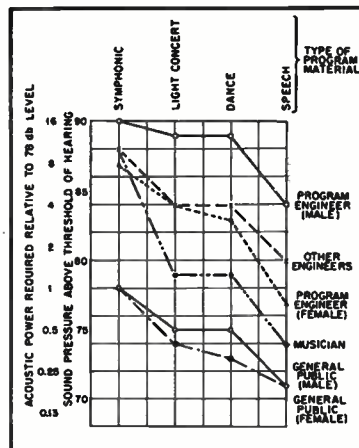

Fig. 1. Preferred average maximum sound pressure levels.

It should be remembered that the "contours of equal loudness" (the Fletcher-Munson curves) show relative loudness only; each curve in the series is plotted 10 db above the preceding curve at 1000 cps, corresponding to an arbitrary increase of 10 db in sound pressure or loudness level (not loudness sensation) at that frequency. As Fig. 2 shows, raising the sound pressure 10 db at 1000 cps does not increase the sensation of loudness in the human mind by 10 db, except in the region of 20 to 40 db sound pressure. This graph is plotted on the basis that the loudness sensation in the brain is a potential or pressure effect, so that a two-to-one change of subjective loudness sensation in the mind

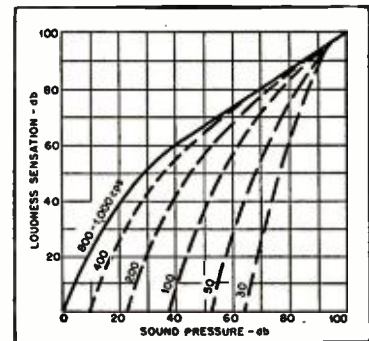

Fig. 2. Relative loudness sensation in the mind for frequencies below 1000 cps. Reference of 0 db corresponds to threshold of hearing, and a 6-db change represents a sound pressure ratio of 2 to 1.

is depicted as 6 db. The 800-1000 cps response then appears as nearly square-law from 0 to 20 db sound pressure, close to linear from 20 to 40 db pressure, and two-thirds law from 40 to 100 db pressure.

This is probably an ideal arrangement from a biological point of view but does complicate matters for the sound equipment designer. The hearing system appears most sensitive to small changes at very low sound levels, a highly desirable condition in the good old days for such purposes as spotting the rustle of a slinking marauder in the depths of the forest. And the ear becomes progressively less sensitive to low-frequency sounds at the lower sound levels, permitting greater concentration on the middle and high

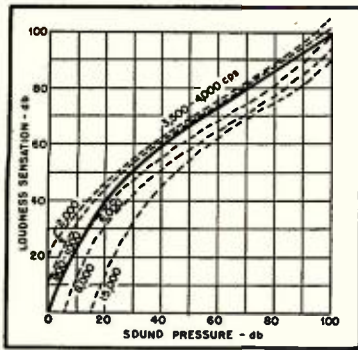

Fig. 3. Relative loudness sensation in the mind for frequencies above 1000 cps.

registers which may carry those tiny warnings of deadly danger. A great variation in loudness sensation occurs with change of frequency below 800 cps over the range of sound pressure from 0 to 100 db. Oddly enough, the loudness response above 800 cps, which is about the geometric mean frequency of the human hearing range for very loud sounds, is much like the 800-1000 cps curve except for substantially constant displacement in absolute value, as shown in Fig. 3.

Transmission Curves of the Human Hearing System

By using Figs. 2 and 3 to determine the values of loudness sensation at the various frequencies for the various sound pressure levels, the transmission graph of Fig. 4 may be constructed. This series of curves shows that the human hearing system, from the air just outside the ear to the impression in the mind, has a response characteristic which is quite constant in form above 1000 cps for constant sound pressure levels of 50 to 80 db. For the same range of sound intensity or pressure, however, the low-frequency region exhibits the interesting phenomenon of a cutoff in frequency which is a function of the sound pressure level. Taking 6 db below the loudness sensation at 1000 cps as the limit, the

following bands of response are obtained from Figs. 2, 3 and 4.

The curves of Fig. 4 are really "fidelity" curves, like those which represent the response of other elements in the reproduction system such as the amplifier or loudspeaker. These hearing curves may be combined with the performance curves of the other sound system elements to arrive at a set of overall transmission characteristics. The listing in Table 1 appears to confirm what many engineers have learned by practical—and sometimes sad—experience; the average listener is not as responsive to frequencies above about 6500 cps as the devout "hi-fi" fan might desire, in fact, the average person's cutoff begins at about 5000 cps. Even this good a high-frequency response is probably the result of resonance in the ear-canal, the short tube leading from the outer ear to the eardrum (microphone cavity resonance). The peaking which appears in Fig. 4 at about 3500 cps indicates such an effect. This is not to say that the frequencies

TABLE 1

Sound Intensity of Pressure Level	f ₁ Low Frequency Cutoff at -6 db	f ₂ High Frequency Cutoff at -6 db
40 db	400 cps	6300 cps
60	200	6700
80	70	6700
90	21	6400

above 6000 or 7000 cps have no importance, for they are essential to the person who wants to hear reproduction of all the music (and noise, too). Unquestionably, the blare and rattle of the brasses, the snap and buzz of side drums, the crash of cymbals, and the tinkle of various triangles all add interest and definition to musical compositions, just as scraping bows, squeaking keys, and breath sounds detract from them. But the average person who is neither musician or engineer nor hi-fi enthusiast cannot be expected to pay a premium for that last octave above 7000 cps, which

is well down in level in the output of most musical instruments as played in their normal ranges, and additionally is about 10 db still lower in transmission through the human hearing system.

Variation in Low-Frequency Response

The same change of 80 to 40 db in sound pressure which produces so little variation in high-frequency response does, however, result in the rather astonishing decrease of about two and a half octaves in low-frequency range at the 6 db cutoff level. This is a sizable slice out of the approximately six and a half octaves of response at 80 db sound pressure (70 to 6700 cps). The effect on the quality of music resulting from a change of this nature is bound to be serious. And in practice we find a widespread public demand for better bass, often subconscious or manifesting itself in such forms as an acceptance of the jukebox or rain-barrel species, or in an insistence on reproduction at levels which excite the latent militancy in neighbors.

Assuming that no severely non-linear elements are present, any variation in the response of one element in the overall sound system may be counterbalanced to a considerable degree by a corresponding but opposite variation in another element. This expedient can usually provide really good compensation only under ideal conditions which will practically never prevail. On the other hand, any reasonable attempt at compensation is certain to result in significant improvement, and it is well worth while if it can be accomplished without much complication.

Computation of Compensation

The first step is to assume an average maximum sound intensity or pressure level which should satisfy the average listener. From the previous discussion, 80 db can be taken as such a figure for music. The problem then is to make reproduction at, say, 50 db average maximum sound pressure sound like a true

[Continued on page 34]

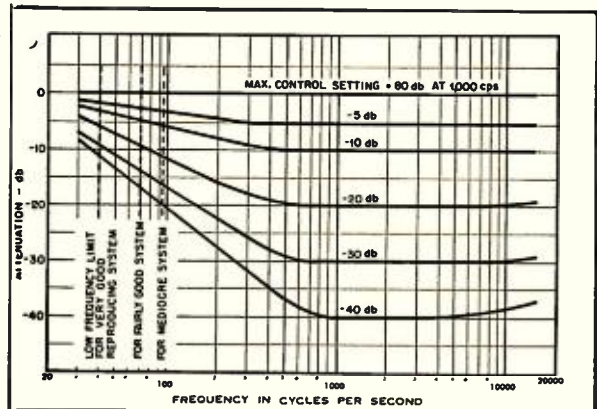
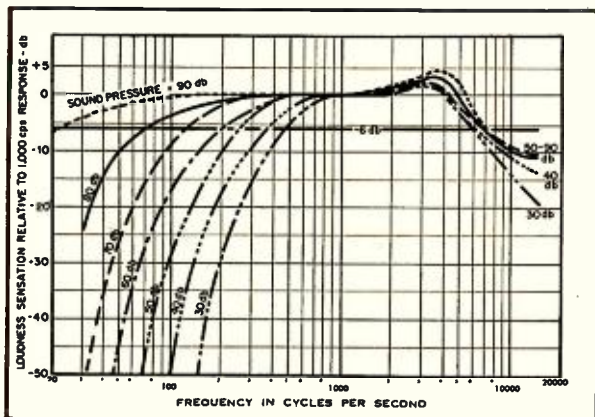

Fig. 4 (left). Over-all transmission characteristic of human hearing system. Fig. 5 (right). Theoretical response of volume control compensated to 80-db standard.

Design for Smooth Response

VERN YEICH*

A simple and effective method of mounting a small loudspeaker in the corner made by two walls and either ceiling or floor.

IN THE BROADCASTING FIELD there has always been a striving for a quality of reproduction suggested by the word "presence." This word quite accurately describes the goal of early broadcasters and manufacturers.

One phase of the development of presence has been the trend toward extended frequency response. This idea was the first to get consideration in the early days of radio, and has ever since received by far the greatest amount of attention. And it true that in order for the reproduction to be a facsimile of the original, flat over-all response is necessary. Although the widest possible range is preferred by most people, facsimile reproduction is not requisite to a convincingly real reproduction of music, and hence a feeling of presence. For instance, we are aware that for a given orchestra, the balance of high- and low-frequency tones will vary from one concert hall to another. The difference will be even more pronounced when the same orchestra is heard outdoors. And although we may thoroughly enjoy our "concert under the stars," the farther we are seated from the orchestra shell, the greater is the effect. We might say, then, that the transmission response of this "real" system is not flat. It will likely be found quite smooth, however. This, perhaps, explains why the small plastic radios have been tolerated; their frequency discrimination is not altogether a new experience.

As a matter of fact, this line of thought seems to lead to the conclusion that the remaining factors detrimental to a feeling of presence might better get a little more attention. A review of the literature shows that the following factors are most important. Some cause wave-shape distortions, and most of them cause response irregularities. The main offenders are: inadequate design in the magnet-voice coil system, non-linear suspensions, cabinet resonances, transient distortions caused by the many resonances in the moving system, irregularities caused by phase relations between units of a multiple system, and room transmission response.

From what has been said, it seems reasonable to expect that an entirely satisfactory reproducing system could be built around a single direct-radiator of superior design, whose response is very smooth, and only as extended as the development of the art permits. This assumes that good associated equipment is used, and that the speaker is properly

buffed, and properly located in a room of good acoustic design.

With this in mind, work was begun on an experimental system using an eight-inch speaker engineered by one of the country's leading acoustic laboratories, and built by a manufacturer certainly suited for the work. It should be expected that its frequency response is as smooth and extended as any similar speaker available. *Figure 1* shows the set up. In the corner of a room with its axis looking down the middle of the solid angle formed by the two walls and ceiling, the speaker enjoys the ideal location for acoustic loading, and room

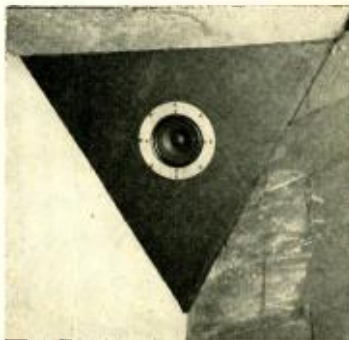

Fig. 1. Front view of the symmetrical corner mounting for an 8-inch speaker of good quality.

coverage. Complying with the manufacturer's recommended volume enclosure, the triangular baffle provides an extremely rigid, resonance-free enclosure with no parallel walls, and no diffracting edges. The speaker was flush mounted to minimize response irregularities caused by speaker-opening cavity resonances. The damping characteristics of the speaker, combined with those of a triode feedback amplifier afforded closest coupling between amplifier input and speaker output.

It seems that the only additional factor which is within the layman's means to help is the transmission response of the listening room, and that is another and important subject. The room used in this case was only fair.

In listening tests the completed speaker system using a Williamson amplifier fed from WWSO's monitoring equipment showed remarkably clean, smooth reproduction. As a result of this experiment, it is felt that smoothness of response is definitely a key factor in the search for realism or a feeling of presence. This experiment, moreover, showed very definite advantages for a symmetri-

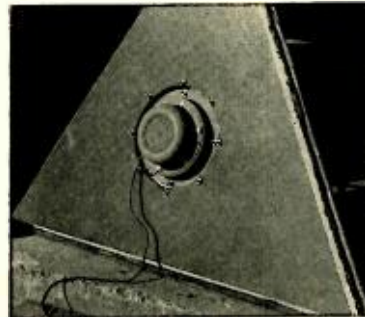

Fig. 2. Rear view of speaker mounting to show use of mounting ring.

cal corner position for better loading and room coverage.

Construction

Building this type of corner enclosure is simplicity itself. It is only necessary to cut a triangular piece of plywood, saw out a hole in the center, and mount the speaker. For the W. E. 755 speaker shown in *Figs. 1* and *2*, the enclosure should have a cubic content of 2 cu. ft., which requires a triangle 39 in. on each side. Table I shows the dimensions for enclosures with various cubical contents.

To provide for the flush-mount adapter recommended for optimum results, a ring of one-eighth-in. sheet aluminum is turned or sawed out, with the hole equal to the free cone opening in the speaker to be used, and wide enough to extend about one inch larger than the speaker all around. This type of mounting reduces the thickness of the material in front of the speaker to a minimum.

If 5/8-in. plywood is used for the triangular piece, it is desirable to line the inner side with some absorbent material such as Celotex or Ozite. For a small speaker—such as the 755—the entire baffle could be constructed from a single piece of Celotex. For permanent fastening to the corner between the ceiling and the walls, it is suggested that strips be attached to both walls and ceilings so that the baffle can be screwed to them.

Since plywood comes in widths of 48 in., it will be necessary to make the baffle out of two pieces if a volume of more than 4 cu. ft. is required. However, the 755 will give good quality, and there are some other types which would serve quite well in the same installation—notably the Permaflux Royal 8, the Altec 400B, the Jim Lansing 208, or

[Continued on page 36]

* Operator, WWSO, Springfield, Ohio.

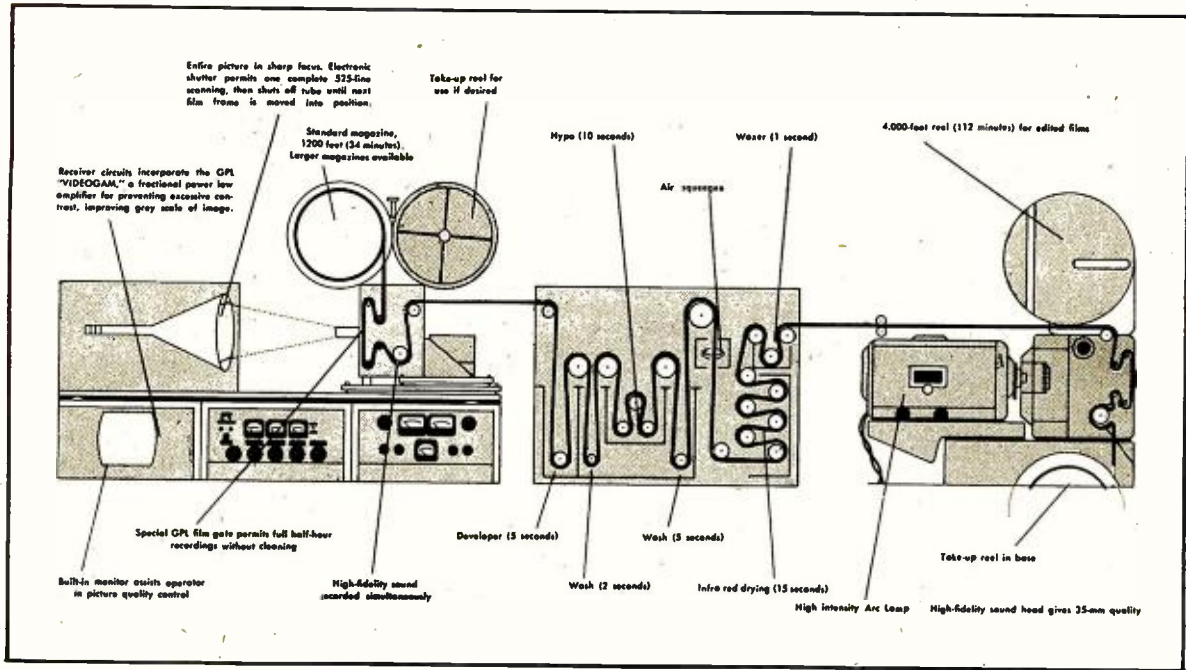

Fig. 1. Block schematic of the entire Videofilm system, from TV picture tube to 16-mm film projector.

The Two Types of Theatre Video

JOHN W. SIMS*

A major development of an entire system for television in the theater is here described, bringing audio readers up to date in a sister field.

THE RAPID GROWTH of theatre TV in the U. S. has resulted in the marketing of a rash of projection equipment, of varying quality and cost. But installations now fall generally into two basic and distinct types: the *film* system, providing immediate or delayed screenings through the medium of video recordings and theatre quality projection equipment; and the *direct projection* system—"done with mirrors"—at lower cost.

At this writing National Theatre Supply, a major distributor to the motion picture industry, is the only source supplying both types of theatre video—the GPL Videofilm System, and the Simplex Direct Projection System. Both were developed by General Precision Laboratory, an NTS affiliate in the General Precision Equipment family, and manufacturer of a wide variety of television studio and field equipment, research instruments, microwave components and similar equipment.

A brief study of these two theatre TV types will bring interested audio-

* General Precision Laboratory, Pleasantville, N. Y.

philes reasonably up to date on the new theatre video industry.

GPL Videofilm

The GPL Videofilm System, consisting of Video Recorder, Rapid Processor and High Intensity Arc Projector, provides immediate or delayed full-screen projection of televised programs. Direct, coaxial cable, or microwave TV transmissions are received on a cathode ray tube, which is part of the equipment, and are simultaneously recorded on standard 16-mm motion picture sound film. A specially designed electronic shutter in the recording unit synchronizes television's 30-frames-per-second with the 24 frames of movie film. Counting circuits allow the receiver tube to be turned on just long enough for the recording camera to scan 525 lines, then shut it off. During the ensuing period, another film frame is moved into place, the tube turns on again, and the procedure is repeated. Thus nothing is visually lost that would not be lost in direct-to-film motion photography. TV's 30 frames are resolved to film's 24 as a result of the use of the electronic shutter. Figure 1 is a "block" schematic of the entire system.

The film made may be either positive or negative. A built-in corrector in the receiver unit improves contrast and gray scale of image, providing sharper and brighter pictures than are possible on any TV home set. Since each exposed frame carries only one complete 525-line scanning of the TV tube, overlap and blurring common with other types of video recorders is entirely eliminated.

High-Speed Processing

From the Video Recorder unit, Fig. 2, the film is fed into the Rapid Film Processor, shown in Fig. 3, where it is developed synchronously with the speed of 16-mm sound projection—24 frames a second or 36 feet a minute. Here it is also washed, fixed, washed again, dried, and waxed—all automatically in 40 seconds. If the film breaks anywhere in the system, the system shuts itself off. Standard developing solutions are employed, with ordinary hose connections providing water, air, and waste facilities. Developer, fix, and wash water are automatically neutralized so they can be discharged into any sewer connection.

When it leaves the Processor, the film

is fed directly into the projection unit, if immediate showing is desired; or to storage reels for later screening.

The 16-mm projector, *Fig. 4*, provided with Videofilm Theatre TV is one of the most important units in the system. A 46-ampere arc lamp puts better than 4000 screen lumens through the lens aperture. The lens resolves 90 lines per millimeter over the entire screen, without a center "hot spot." A sprocket intermittent, running in a continuous oil bath sealed so that no oil reaches the film, is a 35-mm feature new to 16-mm projection. In fact, throughout the design of the Videofilm System, the objective has been to come as close as possible to 35-mm quality while taking advantage of the much greater economies of 16-mm film.

Video Sound Characteristics

A preamplifier is associated with the projector unit in the Videofilm System. This preamp is designed to work into a 500/600 ohm line, but may be reconnected to work into lower impedances such as 250, 125, or 50 ohms. Adjustment of the output level is provided by a step-type gain control. Normal output level from the preamp is 6 mw, but may be increased 10 to 12 db more before there is 1 per cent total harmonic distortion. A socket is provided for a standard plug-in attenuator where the unit must work into low level circuits. When necessary, the level may be as low as -50 dbm without increasing signal-to-noise ratio.

The Video Recorder itself is capable of recording to ± 0.5 db up to at least 7000 cps. By adjusting the separate, independent low- and high-frequency warping controls on the projector preamp, it is possible to obtain an overall frequency response (recorder input to theatre sound system output) of ± 1 db

Fig. 3. The entire "film laboratory" section of the Videofilm system. The Rapid Film Processor develops, fixes, washes, and dries film completely in about 40 seconds.

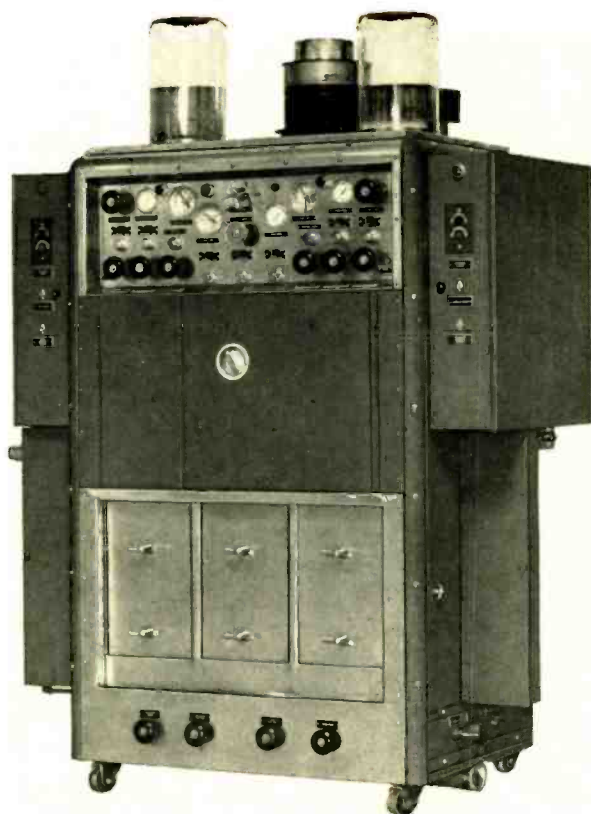

from 50 to 5000 cps, and ± 2 db from 50 to 7000 cps. Five db of high- and low-frequency boost is available, while up to 20 db of high- and low-frequency attenuation may be utilized if desired.

A 20-watt amplifier is available for use in place of the preamplifier where the

recording system is to feed its own loud-speaker. The audio recording amplifier has a step-type input gain control and standard VU meter so that the input level to the recorder may be carefully monitored.

Advantages

The great advantage of the intermediate film system is that a permanent record is obtained. Film may be copied, edited, or stored for later showings. When "hot news" is scheduled for television—such as a championship game or boxing bout, an important announcement by a public official, a homecoming or holiday parade—the theatre program can be interrupted and the important event shown on the screen while it is happening. And it can be *reshown* many times, as long as it has box office drawing power. Or, it can be held for the proper theatre program break.

In Denver, as an example of repeat use, World Series games were shown to a capacity house in the Broadway Theatre with a Videofilm System. As soon as they were shown at the theatre, the films were rushed to the Fitzsimmons General Hospital for immediate showing to veterans.

The second advantage of the film system is its high quality. Resolution, definition, theatre "presence" are at their best where they have been carefully controlled from tube to screen via film.

The Simplex Direct Projection System, consisting of High-Voltage Power

[Continued on page 38]

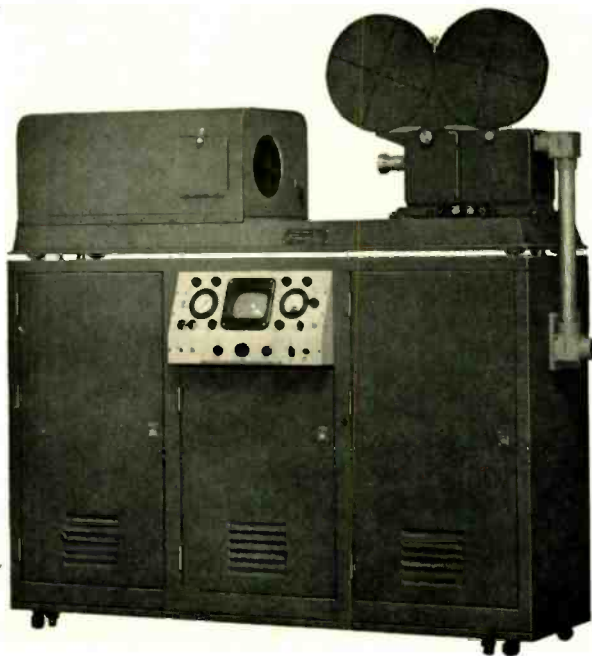
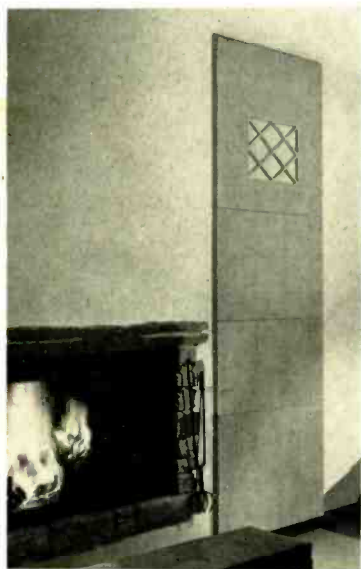

Fig. 2. The Video Recorder unit, which permits photographing either positive or negative film from high quality picture tube.

Audio in the Home

WILLIAM C. SHRADER*

Thirty-two-year old President of the Shrader Manufacturing Company of Washington, D. C., and a leading exponent of custom home music systems.



IN THIS SERIES of articles based on personal experiences over the last fourteen years, we hope to outline a practical approach to the higher fidelity of sound reproduction in your home. It might be a good idea to inaugurate the series with a brief resumé of how we got started in the field.

We began in a one-man radio repair shop, and, being unsatisfied with commercial amplifying systems then available, tinkered around as a hobbyist building our own. The results were unexpectedly gratifying. Some of our customers were sufficiently impressed by the improved tone to want their trade-name sets altered to incorporate our rebuilt amplifier. From this modest start, we advanced to taking the components out of commercial consoles; improving their reproducing ability by rearranging them in the wall or in bookcases and adding professional speakers with

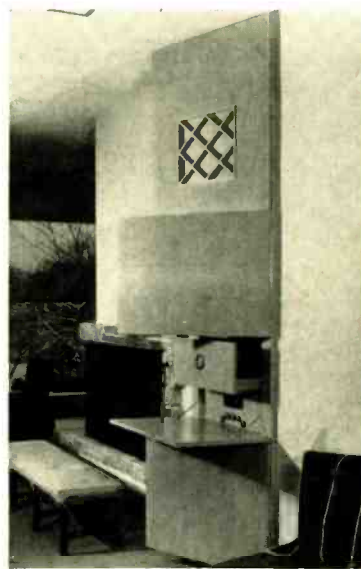

our amplifier. Already sensing the fascination inherent in this kind of work, we sought aid from interior decorators, that our designs might look as well as they sounded.

This was our introduction to the custom home installation, and we soon realized that its development was being retarded by lack of enough suitable equipment. The high-fidelity field, at this time, was virtually unknown to the public, and there were very few lines of merchandise available for home use. We were forced, therefore, to use what we could, and thus became one of the first to adapt professional equipment, on a large scale, to practical home use.

* 2803 M St., N.W., Washington, D. C.

However, only a couple of professional amplifiers were suitable because most were without tone controls or equalization, and there were only two professional lines of speakers. All others were what would be considered today as general replacement type or public-address speakers with limited range—there were no two- or three-way systems, and no single-unit high-quality speakers.

A good home music system requires a stable FM tuner, a quality amplifier, a wide-range speaker in a proper enclosure, and a constant 3-speed player with sensitive pickups. When we entered this business there were, of course, no FM tuners or 3-speed players—nor any records but 78's

PHOTOGRAPHS COURTESY RADIO-WIRE-TELEVISION INC.



to play on them—and few amplifiers or speakers suited to it. Now there are ten or twelve good amplifiers and many respectable speakers at moderate prices. Our business has grown through the constant adaptation of new equipment to current sets, and customers of a dozen years ago have come back in the last five years for FM tuners, and again in the last two or three years for 3-speed players. They have consistently sought better tone through new speakers, better speaker enclosures, and amplifiers with built-in pre-amps to facilitate the use of improved pick-ups.

However, most of these improvements are of recent date. Commercially available products that needed nothing but plugging together have not been long in general use, and amplifiers with built-in pre-amps to accommodate magnetic pick-ups are not an old story. The growing desire for better reproduction of music in his home on the part of the customer has created a demand so great that the manufacturers of electronic equipment now find it commercially feasible to produce it in quantity. Thus, with a large enough quantity of suitable merchandise and a wide enough price range, the field of home installation received such an impetus that it now requires many specialists, in addition to the

Audio equipment in the home does not necessarily have to be housed in revamped orange crates in order to sound good—it can just as well be built into period, modern, functional, or even bizarre furniture designs, as shown in these examples. Or even better, accommodations for speakers, record players, tuners, and amplifiers can be as fully built in as is the heating system. Aside from certain requirements for ventilation and acoustics, it is up to the ingenuity of the builder.

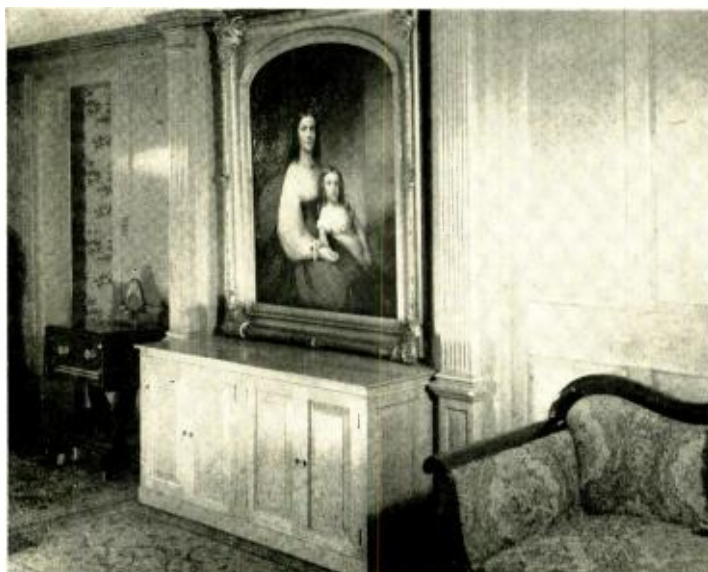

PHOTOGRAPHS COURTESY ELECTRONIC WORKSHOP SALES CORP.

musician or music lover, to complete a system properly. These may include engineers, technicians, cabinet-makers, interior decorators, and architects, to conceive, plan, design, and build the systems. All of them must be unified by a co-ordinator who expresses the customer's desire to all of them. This extremely complex arrangement is not always necessary. For the most part, sales engineers can visualize and foresee the results and can give advice on what components will work well together, the best way to connect them, the acoustic properties of different cabinets, and, in this way, keep the cost down for customers who wish to have good music in their homes but cannot afford the best set that can be installed in leisurely fashion by four or five specialists.

Choice of Components

Choosing the proper equipment is of great importance if the optimum performance is to be obtained from each item. Any persons who seek to select their own components solely from a catalog will encoun- [Continued on page 46]



Music's the Thing

IRVING GREENE* and MELVIN C. SPRINKLE**

Combining gracious living with great music, a great stage star sets the stage for "Audio in the Home."

WHEN WILL SHAKESPEARE wrote *Hamlet*, he aptly advised, "The play's the thing." Three hundred years later, Miss Katherine Cornell, one of the country's leading Shakespearean actresses, paraphrased the Bard's advice in making "music the thing."

"I've always wanted to live in a barn," said Miss Cornell to a close friend while discussing a new home she had decided to build in Rockland County, New York. Her friend happened to be one of the leading architects in the country, so he set out in search of a suitable barn—locating a huge, sturdy one reputed to be over a hundred and fifty years old some sixty miles away on Long Island.

Plans for the house were centered around the barn, and work was soon begun. The foundation was virtually blasted in the rocky Palisades terrain and the barn was moved in sections from its original site and expertly reconstructed on its new foundation. The remainder of the house was then built around it. This barn is by no means diminutive—measuring 34 by 45 feet, and extending up to 28 feet high at the inside tip of the peaked roof. The side walls, which extend to a height of 18 feet, are paneled with a unique Central America wood cut from the logs of the Genezero tree, a member of the mahogany family. The texture and body of the Genezero paneling is softer than most varieties of mahogany, and serves to enhance the acoustic quality of so large a room. This barn-living room was planned as the center of all entertainment and activity.

Music Interest

Once the house was well under way, Miss Cornell concerned herself with a medium for the reproduction of music to provide entertainment for her guests—as well as for herself. Her interest in high-fidelity equipment stemmed from a visit to "Doolhagen," a neighboring estate belonging to Dr. Cushman D. Haagensen, who is on the professorial

* Manager, Audio Dept., Sun Radio & Electronics Co. Inc., 122 Duane St., New York 7, N. Y.

** Altec Lansing Corporation, 161 Sixth Ave., New York 13, N. Y.

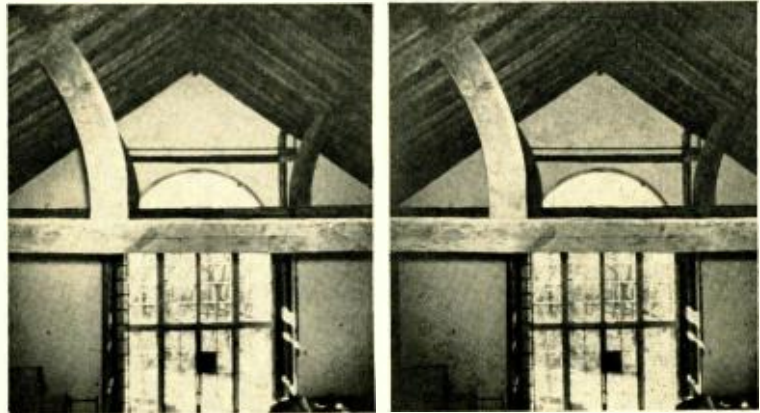

Fig. 1. View of the end of the barn-living room opposite the location of the speaker system. Note that these two pictures constitute a stereo pair. If you stare at them for a moment or so, your eyes may spread apart and you will see the three-dimension effect. It is perhaps easier—for the first time—if you hold a piece of cardboard perpendicular to the page at the dividing line, and view each photo with but one eye. Try it and see for yourself, then turn to page 10 and read Editor's Report.

staff of the Columbia University School of Medicine. Dr. Haagensen played records for Miss Cornell through his own system, which consists of a Reko-Kut LP-743 turntable, a Pickering 190 arm and two Pickering diamond cartridges feeding Altec Lansing amplifiers and speakers.

After many moments of pleasure listening to the music of her favorite composer—Tchaikovsky—Miss Cornell and her manager, Gertrude Macy, were convinced that "music's the thing." With the kind assistance of Dr. Haagensen, Miss Macy had the estate surveyed for installation of a high-quality music system. The requisites were plain and simple—except for one restriction. No furniture was to be involved in any manner with the speaker or the equipment. This meant that the equipment would have to be installed in one of the many closets surrounding the barn on the main floor, since the barn had become the center of the house. The difficult task which lay ahead was the installation of a proper speaker system in one of the walls. For loudspeaker equipment, a small theatre system was selected, inasmuch as the length and breadth of the barn were more than

twice that of the ordinary living room. One idea of its size may be had by observing Fig. 1 which is a view from the "Loom Room" at one end of the barn at about the second-story level toward the arched doors in the opposite end. Another factor in making the choice for a theatre system was the height of the room, which equaled that of many small movie theatres. The Altec Lansing 800 system was actually designed for small theatres, and consequently served this installation admirably.

Speaker Systems

The word *system* used to describe this model should be emphasized. A speaker system differs from a "woofer-tweeter" combination in that the sound from the former is a euphonic blend of high and low frequencies. The addition of a tweeter to an existing speaker does not *automatically* assure best quality sound, since difficulties in phasing the units often arises, and may cause an unpleasant effect which may not be easily located.

It is well known that the modern motion picture theatre has exceptionally good reproduced sound. This is no accident, but is the result of years of

experience and the combined efforts of the country's leading audio engineers. Almost without exception, theatre systems in use today consist of one or more woofer speakers which are coupled to the air by a direct-throw exponential horn, and a high-frequency horn with a driver unit employing a metallic diaphragm. The crossover frequency is usually 500 or 800 cps, depending upon the size of the installation—the higher crossover frequency being used with the smaller systems.

These fundamentally sound design principles are incorporated in the system selected. A 15-in. woofer speaker is coupled to a short horn. This type of horn is used because it is the best method yet devised to couple a loud-speaker diaphragm to the atmosphere, serving as an acoustic transformer which provides an impedance match. By this method of loading the speaker, efficiency is increased, and bass response is "cleaner." The proper amount of bass-reflex action is added to augment the very low frequencies.

Frequencies above 800 cps are reproduced through a high-quality driver unit coupled to a multicellular exponential horn which assures uniform distribution of the high frequencies.

Speaker Location

The one location that would place the speaker system in a position to provide proper coverage of the entire room was that above Miss Cornell's loom room, yet while there was sufficient room *inside* the barn-living room, there wasn't *outside*. The loom room was in an extended portion of the house which had a roof lower by four feet than that of the barn. If it had been aesthetically possible, the sound radiating requirement would have been adequately satisfied by



Fig. 2. Another stereo pair. Mr. Green in the throes of installing the speaker system in the structure built just to house it on the roof. This in one installation where the user won't be changing the balance between high- and low-frequency units very often.

hanging the entire speaker system from the rafters. But everyone agreed that it would not present an appearance in keeping with the decor of the house.

A solution to the problem was effected with the assistance of Mr. Bernard Beck, a staff architect with the firm which designed the house for Miss Cornell. He laid out plans for an outer structure designed to house the speaker system on the roof, above the loom room. The low-frequency speaker enclosure was laid on its side and angled downward into the room at an angle of 30 deg. from horizontal, and the high-frequency horn was mounted atop the bass enclosure—on what is normally the side. *Figures 2 and 3* indicate the general design of the exterior speaker housing. Considerable care was taken to maintain proper phasing at crossover between the low- and high-frequency sections properly. Improper phasing manifests

itself as a very rough transition between the two frequency bands, producing a "hole" in the important midrange. The crossover network was mounted adjacent to the high-frequency driver unit. The transmission line was run from the speaker in 1/2-inch flexible conduit inside the walls, using 14-ga. two conductor Romex cable, to closet No. 74 which was chosen for the equipment location. The conduit was terminated in a standard 3-in. round outlet box.

The outer structure is well built, in order to provide excellent protection from any form of inclement weather. The roof of the structure is made of copper and the access doors in the rear provide entry for any needed servicing. Although it was not an acoustic requirement for good sound radiation into the living room, the interior of the structure was lined with one-inch celotex only for the purpose of soundproofing it to the outside.

The quality of reproduction is all that could be desired, with realism and presence comparable to natural live sound. Directly opposite the speaker system are partially draped glass doors, as seen in *Fig. 1*, which provide a surface that partially absorbs and partially reflects, making a pleasant balance. The height of the high-frequency speaker is advantageous as there is no pronounced beaming effect and the high-frequency coverage throughout the room is crisp and clear. The front of the system is covered with Lumite plastic grill fabric of a color which blends with the natural finish of the Genezero panels.

Equipment Housing

Closet No. 74—believe it or not—houses the components of the system, and is located near one of the entrances to the living room. The door to the closet is in the main hall, and a master switch at the door controls all power to the

[Continued on page 43]

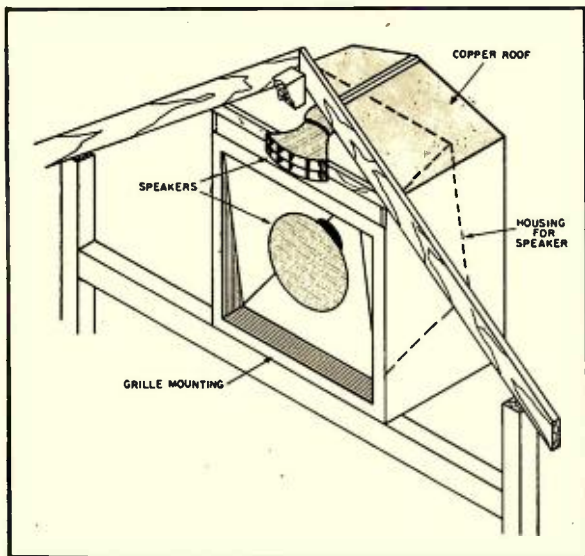

Fig. 3. Isometric sketch of the speaker housing at the peak of the living-room roof.

Horn-Loaded Bass Speaker

EARL R. MEISSNER* AND L. K. ANDREWS**

The swing to better bass response is solved by a method which is available in one form or another to anyone with patience, fortitude, lumber, a saw, and a hammer.

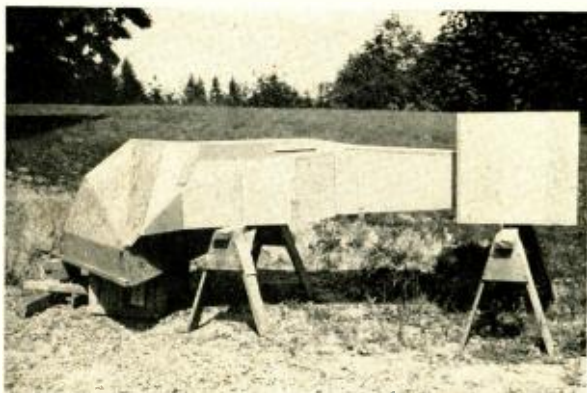

Fig. 1. Side view of low-frequency horn designed for mounting in an attic, with the horn mouth entering the room through a corner of the ceiling.

AFTER MUCH EXPERIMENTATION and careful listening to conventional types of reproducing systems, it appears to us that there is more room for improvement in the bass range than in any other part of the audio spectrum. A great improvement in the middle range of our three-way speaker system had been noted when a Western Electric 15A "Morning Glory" horn and a 555 driver unit had been installed. The question naturally arose could a comparable advantage be obtained by horn loading the bass speaker?¹

Thoughts lead to action, so—taking a quick measurement of the front door and the arch between the living room and dining room, it was apparent that a five-foot square horn mouth could be squeezed in. Just to keep the mathematics simple, we decided to halve the cross sectional area for every foot of axis. One of our engineering friends informed us this gives approximately a 63-cps cut-off exponential horn. So section by section, an experimental horn was constructed of three-quarter-inch plywood (they give it away in Oregon), until it extended through the living room, dining room arch-way and to the back wall of the dining room.

When the throat was down to the 3 x 3 in. size, we connected our bass

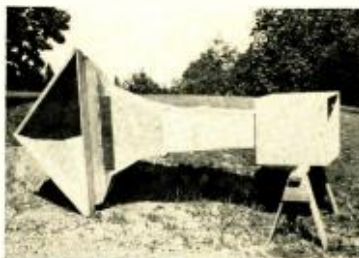

Fig. 2. "Bottom" view of the horn, to show triangular mouth.

"woofer," a four-inch \$1.59 speaker, and gave it the listening test. It sounded darned good. To get a comparison, a fifteen-inch co-axial speaker, mounted in a commercially built bass-reflex cabinet was set up for A-B testing. The results were all in favor of the horn and the \$1.59 speaker. With this encouragement, a fifteen-inch woofer, Stepsens 103LX-2, was obtained, and the results were even better. The bass was much smoother with far less distortion com-

pared to anything we had heard, including folding type corner baffles. The transient response was markedly improved and the whole bass range was much "cleaner." Thus the question as to whether comparable advantages would be obtained by horn loading the bass speaker was definitely answered in the affirmative.

To determine the best match of the horn to the speaker, a few inches of the horn were cut off at a time, until we arrived at a throat area of 100 square inches, which we thought gave the best results. An engineering friend with a well-trained slip stick advised that this gave unity loading for a 15 in. cone.

Domestic Distortion

However pure and well-damped the tones emerged from the horn, there were persistent rumblings within the household. With the usual engineering approach, we went to work tracing these spurious frequencies. We knew the 50-watt amplifier had less than one-half of one per cent distortion, so that was ruled out. Again applying the listening test, we traced it to Mother and determined that it had something to do with the size of the horn and the fact that she had not been able to use the dining-room for three months! Now we knew the rumblings were ominous, and not to be solved by slide rule. Neighbors had added to the discord with a remark like "What in the World!" or by politely ignoring the colossus while carrying on a sprightly conversation as to how well the delphiniums were going.

A hasty consultation was held and in the interest of family relations, the horn was reduced to kindling wood. As time passed, however, we noted the children missed the horn, around, under, and in which they had played hide-and-seek.

[Continued on page 36]



Fig. 3. By constructing the horn in sections, it is possible to handle it without the aid of a crane.

*United Radio Supply, Inc., 22 N. W. Ninth St., Portland 9, Ore.

**Engrg. Dept., Pacific Telephone and Telegraph Co., Portland, Ore.

¹Since then, several articles have appeared, showing the high distortion in speakers below 100 cps and the improvement to be expected if horn loaded. See "Loudspeaker Enclosures," by Daniel J. Plach and Philip B. Williams in *AUDIO ENGINEERING*, July, 1951, p. 12; and "Loudspeaker diaphragm control," by J. Moir, *Wireless World*, July, 1951, p. 252.

it's red hot!



hundreds of PRESTO

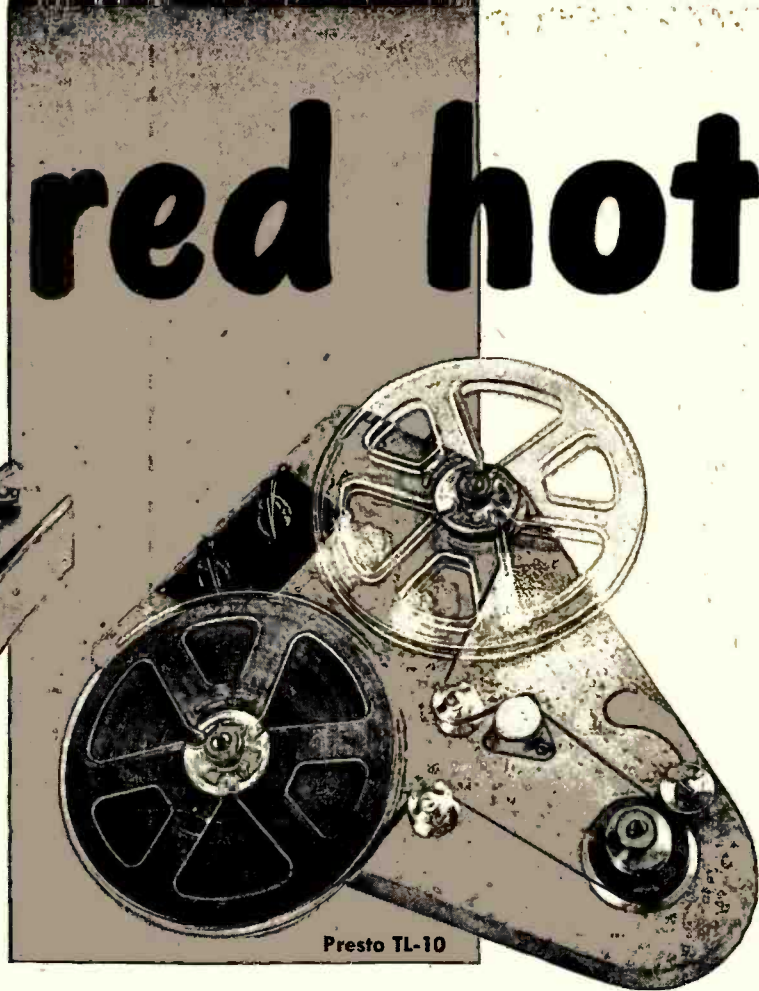

Turntable Tape Reproducers sold in the past six months!

Since its introduction last spring, sales of the new PRESTO TL-10 have surpassed even our expectations. The reason . . . it's an *inexpensive instrument that fills a definite need* in the nation's stations and recording studios. Look at the advantages listed below—then join the ranks of the hundreds of satisfied TL-10 users by calling your PRESTO dealer today.

- Reproduces tape quickly and efficiently—without tying up a regular tape recorder.
- Easy to attach and remove from any standard 16" turntable.
- No motor—turntable acts as motor.
- Can be plugged into any standard speech input equipment.
- Speeds of 7½" and 15" per second, response up to 15,000 cps.
- Easy to operate and maintain.
- Costs only \$140.00 complete, but has reproduction quality and fidelity of a high priced machine.

The TL-10 is an exclusive PRESTO product—made by the world's largest manufacturer of recording equipment and discs.

PRESTO RECORDING CORPORATION
PARAMUS, NEW JERSEY

Export Division: 25 Warren Street, New York 7, N. Y.

Canadian Division: Walter P. Downs, Ltd., Dominion Square Bldg., Montreal

WORLD'S LARGEST MANUFACTURER OF PRECISION RECORDING EQUIPMENT AND DISCS

Two Preamplifiers for Magnetic Pickups

GEORGE ELLIS JONES, JR.*

For those who are never satisfied with existing preamplifiers, these should be attractive. One provides variation in specific turnover points with several roll-off characteristics, while the other provides a continuously variable turnover point.

PROPER REPRODUCTION of sound from phonograph records requires, in general, two types of compensation since both low-frequency attenuation and high-frequency pre-emphasis are introduced before or during the cutting of a "master." Since the recording characteristics vary among different manufacturers and even among different recordings offered under the same label, it is desirable that the playback system afford adjustable compensations. This need exists no matter what kind of pickup is used and obtains for all three recording speeds.

Tone-control systems, including those which provide both boost and attenuation independently for bass and treble, are not particularly suited to this purpose.

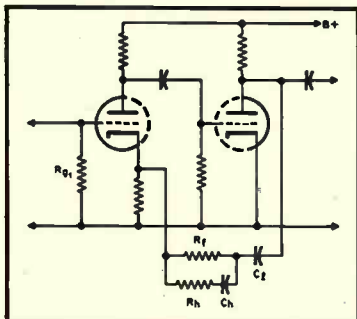

Fig. 1. Basic circuit of first type of preamplifier with adjustable turnover points and roll-off characteristics.

It may be observed that these systems affect primarily the rate of gain change with frequency and to a lesser extent the range over which the gain remains constant. The author prefers to use a preamplifier with adjustable compensation feeding through a volume control to a flat main amplifier, rather than a preamplifier with some fixed average compensation followed by a tone control system and then the main amplifier. No additional tubes are needed in an adjustable preamplifier as compared to one with only fixed compensation. On the other hand, a tone control system providing both boost and cut may be expected to include vacuum tubes so that additional noise, distortion, and varying phase shift will be introduced.

* Instructor, Chemical Engrg. Dept., The University of Pittsburgh, Pittsburgh 13, Pa.

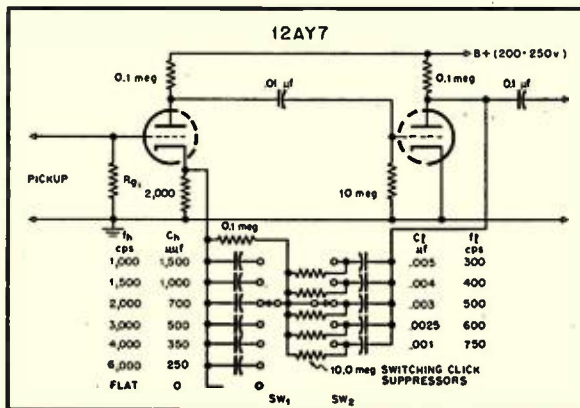

Fig. 2. Complete schematic of pre-amplifier shown in basic form in Fig. 1.

In the past, three methods have been presented for obtaining desired high-frequency roll off:

(a) Loading the pickup with an adjustable resistive load so that the inherent inductive reactance of the pickup will cause a roll-off of 6 db per octave. The frequency above which this roll-off obtains is influenced not only by the value of the load but also by the magnitude of the pickup inductance, which

varies significantly among manufacturers.

(b) Placing a high impedance network between the pickup and the preamplifier input.¹ The operation of this net is based on the assumption that over the frequency range of interest the pickup's inductive reactance will be much

¹ St. George and Drisco, "Versatile phonograph preamplifier," *AUDIO ENGINEERING*, March, 1949, p. 14.



Fig. 3. Internal construction of first type of preamplifier.

TYPE M BLONDE OR CORDOVAN MAHOGANY—FOR 15" SPEAKERS

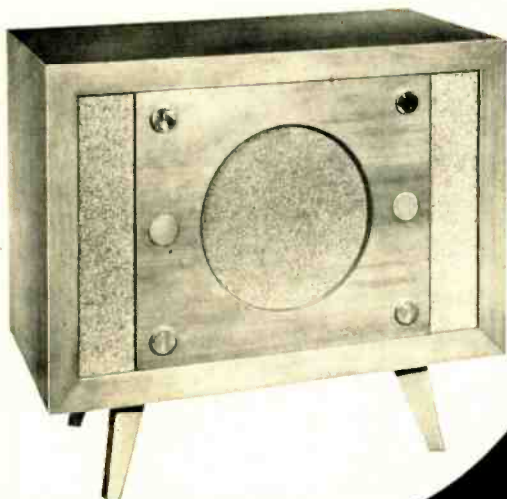

TYPE D WALNUT—FOR 12" OR 15" SPEAKERS



the perfect setting
for a fine loudspeaker

Jensen

BASS REFLEX CABINETS

acoustically-correct
handsomely styled
durably constructed

Jensen loudspeaker cabinets are acoustically-correct, accurately proportioned bass reflex enclosures. In addition to fine acoustic performance, they combine modern beauty, decorative and functional adaptability with convenient features for easy installation. For further information, write for Data Sheet 162

Jensen MANUFACTURING COMPANY
Division of the Muter Company
6601 S. LARAMIE AVENUE • CHICAGO 38, ILLINOIS

TYPE C BLONDE OR MAHOGANY FINISH—FOR 8", 12" OR 15" SPEAKERS



TYPE J WALL OR POST MOUNTING—BROWN LACQUER FINISH—FOR 6" OR 8" SPEAKERS

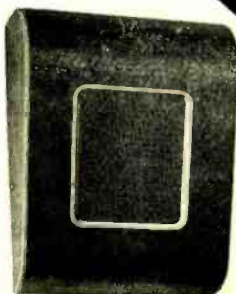

(PERIDYNAMIC TOTAL ENCLOSURE)

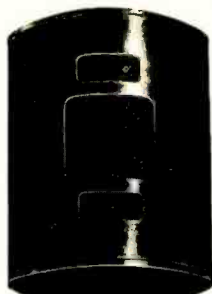

TYPE H BROWN LACQUER FINISH FOR 8" SPEAKERS

TYPE B BROWN LACQUER FINISH—FOR 12" SPEAKERS

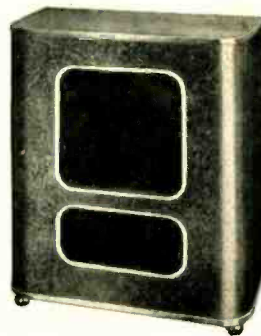

BURTON BROWNE ADVERTISING

smaller than the network impedance. This will be only approximately true; and in addition, the relatively high impedance of the network is a possible source of hum pickup.

(c) Placing a high-frequency attenuator after a preamplifier with a flat high-frequency response.² With this arrangement the output voltage at high frequencies from the preamplifier may be of sufficient amplitude to be distorted. Furthermore, the output impedance of the high-frequency attenuator will be much greater than that of a well designed preamplifier.

The preamplifier shown disassembled in Fig. 3 obtains the desired high-frequency roll-off by adjustment of the feedback loop. This unique method for removing high-frequency pre-emphasis has several advantages:

(a) The preamplifier input is of low impedance and readily adapted for any magnetic pickup.

(b) Both the roll-off frequency and the rate of attenuation above this frequency are readily controlled.

(c) The output impedance of the preamplifier becomes very low at high frequencies due to the increase in feedback at these frequencies.

Circuit Design

The essential components of this preamplifier are shown in Fig. 1. It will be noted that with the exception of C_h and R_h , the preamplifier is essentially that presented by Sterling³ as a modification of a Pickering preamplifier. When R_h is equal to zero, a high-frequency roll off of 6 db per octave occurs; the gain having fallen 3 db when the frequency has risen to that given by the relationship:

$$f_h = \frac{1}{2\pi R_f C_h}$$

In the event that R_h is one fourth of R_f the roll-off rate is about 3 db per octave over a range of frequency from:

² H. T. Sterling, "Simplified preamplifier design," *AUDIO ENGINEERING*, November, 1949, p. 16.

$$f = \frac{1}{2\pi(R_h + R_f)C_h} \text{ to: } f = \frac{1}{2\pi R_h C_h}$$

Because of the loading effect of the feedback loop on the second triode, the gain falls below unity at high frequencies before the phase shift becomes 180 deg. Oscillation does not occur, nor does square-wave excitation reveal any ringing. The high-frequency roll-off is selected by switching one of several available R_h and C_h combinations across R_f , so as to complement the recording pre-emphasis.

For low-frequency compensation, a rising characteristic of 6 db per octave is obtained by the combination of C_i and

not extend to the very lowest frequencies. Low-frequency turnover is established by switching an appropriate capacitor value for C_i into the backfeed loop.

Figure 2 is a complete schematic for this preamplifier as constructed by the author. The chassis was fabricated from sheet aluminum and when assembled places the control shafts on the side opposite the tubes and cable connections. This is a convenient arrangement, since the preamplifier can thus be mounted beneath the phonograph motor board or against the rear of the control panel. The schematic does not indicate the decoupling resistor and electrolytic filter capacitor since their values will depend

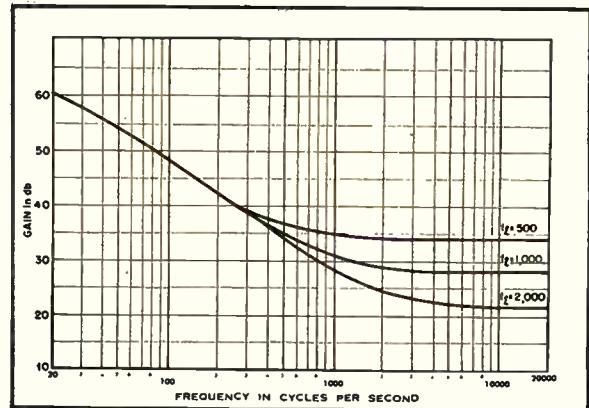

Fig. 6. Response curves obtained with second preamplifier.

R_f , the gain having increased 3 db when the frequency has fallen to that given by the relationship:

$$f_l = \frac{1}{2\pi C_i R_f}$$

This technique for obtaining low-frequency compensation is quite common, but does have the disadvantage of reduction in feedback and increase in output impedance with decreasing frequency. Furthermore, if the turnover frequency, f_l , is increased much above 500 cps, the rising characteristic does

on the B-supply voltage available. For the tube, the author has used with equal success a 12AY7 or a selected 12AT7. The second tube is but slightly more microphonic but does provide a better rising bass characteristic. This advantage is brought out by Fig. 4, which shows the gain vs. frequency curves calculated for the author's unit.

Continuously Variable Turnover

Another preamplifier obtains compensation variation with variable resistors rather than by capacitor switching. Originally conceived as a compact and

[Continued on page 39]

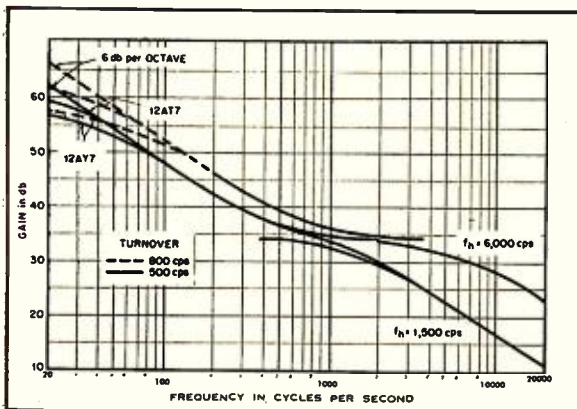

Fig. 4 (left). Typical response curves obtained with first preamplifier.

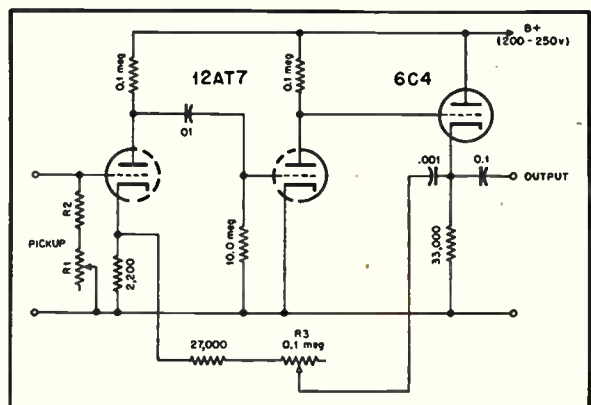

Fig. 5 (right). Schematic of second preamplifier, with continuously variable turnover point.



NEW **E-V** DEVELOPMENT IN A COMPLETE, COMPACT
800 cps Separate 2-way Speaker System
(CROSSOVER)

**GIVES SMOOTHER, CLEANER
 REPRODUCTION OF
 EXTENDED LOWS AND HIGHS**

Aristocrat I and II

For the first time, you have all the advantages of super-efficient separate 2-way operation . . . in such a compact, integrated, low-cost speaker system. Superb bass response . . . new E-V diffraction principle of high frequency sound dispersion . . . and a low crossover point with high transfer efficiency . . . assure smoother, cleaner, more extended lows and highs. New patented Hoodwin Diffraction Horn provides perfect dispersion of high frequencies through a 180° solid angle.

Supplied complete in beautiful ARISTOCRAT Corner Cabinet, or can be used separately in wall, door or other existing enclosures.

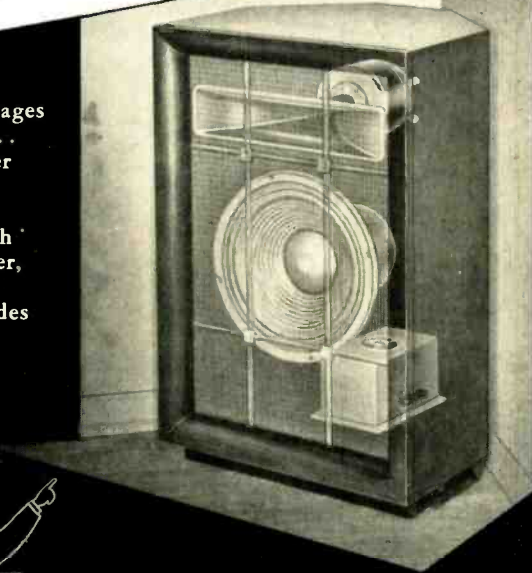

ARISTOCRAT II • Includes E-V Model 111 Deluxe 800 cps Separate 2-way Speaker System completely wired and installed in ARISTOCRAT folded corner horn cabinet enclosure. 29½" high x 19" wide x 16½" deep. Net wt. 91 lbs.
 List Price: Mahogany, \$340.00; Blonde, \$346.50



Model 111 Deluxe 800 cps Separate 2-Way Speaker System • Consists of 12W L-F Driver, T-25 H-F Driver, 8-HD Hoodwin Diffraction Horn, X-8 Crossover Network, AK-1 Accessory Kit of mounting hardware and black flat baffle with cut parts. 27"h. x 18" w. x 13½" d. Net wt. 48 lbs.
 List Price, less cabinet \$255.00

ARISTOCRAT I • Includes E-V Model 108 Economy 800 cps Separate 2-Way Speaker System, completely wired and installed in ARISTOCRAT folded corner horn cabinet enclosure. 29½" h. x 19" w. x 16½" d. Net wt. 72 lbs.
 List Price: Mahogany, \$265.00; Blonde, \$271.50

Model 108 Economy 800 cps Separate 2-Way Speaker System • Consists of 12BW L-F Driver, T-10 H-F Driver, 8-HD Hoodwin Diffraction Horn, X-825 Crossover Network, flat black baffle with cut ports and AK-1 Accessory Kit of mounting hardware. 27"h. x 18" w. x 12½" d. Net wt. 29 lbs.
 List Price, less cabinet \$165.00



ARISTOCRAT (Klipsch-Licensed) Folded Corner Horn Enclosure for single 12" full range speaker. Mahogany, less speaker, List \$ 99.50
 Blonde, less speaker, List \$106.00



Send Now for Bulletin 189

Electro-Voice
 400 CARROLL STREET • BUCHANAN, MICHIGAN

Suppliers to the Radio and TV Networks

HI-FI SPEAKERS • MICROPHONES • PHONO PICKUPS • TV BOOSTERS
 Export: 13 East 40th Street, New York 16, U.S.A. Cables Arlab

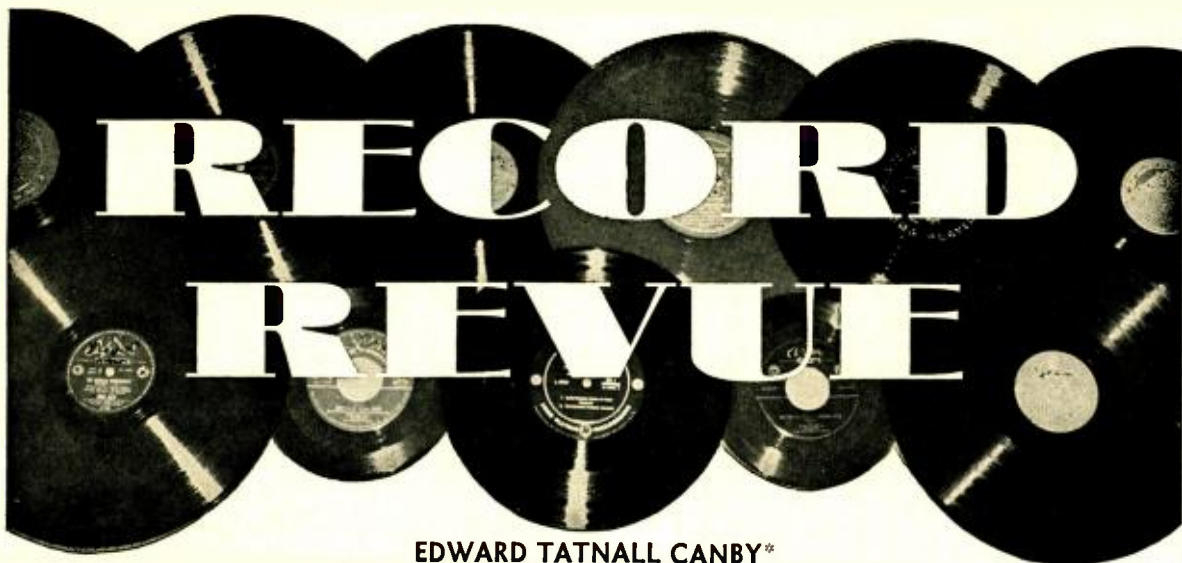

EDWARD TATNALL CANBY*

JUST TWO YEARS AGO, in the January 1950 issue of *Æ*, I wrote out a set of thoughts upon a vexing and yet very interesting subject, the relationship between binaural and monaural hearing and the desirability of some sort of working formula that might put this relationship into more useful terms than now exist. We hear binaurally. But we record and broadcast monaurally.

The inquiry was mostly theoretical. I had not then had any chance to hear binaural sound other than the normal 16-odd hours *per diem* during which my two ears work more or less together. Binaural broadcasts and recording were not available in any immediate form. My interest in the binaural aspect, then, was principally from the point of view of the microphonist—who must work out an equivalent, in monaural terms, of the “natural” live sound heard by two ears. This is no more than the standard problem of all recording and broadcast mike pickup; the trouble is that two few among those who practice monaural miking ever stop to consider that there is a startling and very great difference between the two types of sound as we hear them, and that their skill is, after all, based on a rough-and-ready (or calculated) ability to judge equivalents, between the sound heard on the spot by two ears and the sound to be heard monaurally via the mike. You can't mike anything without matching binaural against monaural—yet precious few of us have stopped to figure out the ins and outs of the relationship (if we even so much as know of its existence).

Binaural Tape

But now comes a wholly new extension of the scope of this problem. Binaural tape. I refer you back to the January, 1950, issue for the possibility of a more useful “scale” of relationships between binaural “live” hearing and equivalent monaural pickup—now we have a far more specific problem to tackle. We have binaural, two-channel recording.

For more than a year I've been in communication with one tape recorder outfit that has been working up a two-channel recorder and play-back using conventional double track tape. Due to necessary government side-tracking (dual-channel re-

Monaural and Binaural— Interim Thoughts

ording for special industrial measurements or some such project) that machine is still not forthcoming. However, unbeknownst to me, the Magnecorder company had been following the same lead. At the Audio Fair the first examples of binaural tape made on a conventional recorder system (i.e. with standard tape and standard speed) were introduced. I count the hearing of the Magnecorder binaural tapes as one of the most significant experiences I've had in the last few years.

Two-channel Listening

The experience was exciting because, first, it confirmed in practice a batch of things I had expected in relation to dual-channel sound; secondly, it was exciting because it points the way, to me anyhow, towards some very startling practical developments-to-come; thirdly because in some fifteen minutes of actual listening I learned more about binaural sound than in a good three years of gabbing and gassing and theorizing on the subject!

I am getting the loan, for experimentation, of one of the new systems as soon as available and shall have much to report on it, I expect. Meanwhile in the space left, let me note a few vital observed points, and make a proposition or two.

1. Two-channel recording is a tremendous experience musically in comparison with even good one-channel work. It is startling via earphones, the theoretical ideal. *Except* that as one turns one's head the reproduced sound turns too, adding a dizzy effect that is *not* realistic at all. A switching from one to two channels on the phones gave an impression of a tremendous bursting-outward into space; the one-channel sound, in comparison, seemed cramped and close, a private world only inches away from one's ears; the binaural sound suddenly jumped away in all directions as though the performers had leapt into the air; suddenly they were more than room distance away and full sized, alive. I won't soon forget that effect.

2. So much for phones. But more important in a practical sense by far was the

reproduction via two speakers in adjoining corners of the room. This is supposed to be a horrid compromise and it shouldn't work. Everything is again it. The results ought to stink. Both ears hear both speakers; the binaural effect can't be more than, say, 30 per cent efficient. And yet the plain fact was that to me and others present the speaker reproduction was not only fabulously effective and realistic but was *easily more pleasing than the (theoretical ideal) earphone system of reproduction.*

I suspect a factor was the room-stability of the sound—when you moved, the music stayed put and there were no performers flying madly about the room in dizzy circles! But other factors weren't so easily accountable. I'd guessed, in any case, that literal, absolute reproduction was not the goal of a practical two-channel recording, but rather a gain, small or large, in *apparent* realism—fake or otherwise. That gain was greater than I had expected.

False Direction

No question—false spatial and directional relationships can and do occur very easily in the reproduction via two speakers. At some points in the music I discovered that a soloist would be double; one of him could be heard in the direction of each speaker. A thoroughly unreal effect; and yet *musically* it did not matter in the least. (After all, the two “doubles” played the same music!) The effect of realism was still terrific.

Indeed, I began to realize that even though the two-speaker system was obviously quite addled and would always be so as far as phasing and directionality are concerned, still, the two-speaker, two-channel sound was just plain gorgeous in its realism and presence. Evidently the dual-channel system was giving the ear a wealth of something that it hugely needs and dotes on when it gets it. I'm not entirely prepared to say what. This is an interim observation. Let's begin with the premise that the thing works! We'll find out how and why, as we go along.

4. Liveness. My expectations were here gratifyingly confirmed. *Viz:* A high school chorus in a gym was recorded, by mistake, with only one mike open, on one channel. Off-mike effect, distant, thin liveness, a

[Continued on page 30]

* 279 W. 4th St., New York 14, N. Y.

NEW (diamond)

chromatic polyphase



Available with the new Compass-pivoted
Audax Arms and for Record Changers

For three long days, at the recent Audio Fair, crowds were literally transfixed by the superb performance of the new CHROMATIC (diamond) POLYPHASE. They actually stood in line, waiting their turn to come into the concert hall, to hear it.

The CHROMATIC POLYPHASE, deliberately placed in the open*, at the very elbows of the audience, the volume control was suddenly turned off to zero, right in the middle of the concert, while POLYPHASE continued in the groove of the rotating disc. The total silence that followed amazed the audience**—The question that was asked and still being asked . . . “What makes such performance possible?”

In Weil's ELECTRONICS PHONO FACTS, Pointer 77 says—“Near-zero vibrating mass and near-infinite compliance are the basic MUSTS for ear-quality. The compliance must be so great that the groove will have absolute control of the stylus—at all times. The seriousness of needle noise is in damage inflicted on the grooves by the factors which cause the noise.” . . . The New CHROMATIC POLYPHASE does away entirely with these highly destructive factors and is therefore free of needle noise.

This is only part of the answer. The rest is in the all-important KNOW-HOW that comes only with years of experience.

“The Standard by which Others are Judged and Valued.”

AUDAK COMPANY

500 Fifth Avenue

New York 18

“Creators of Fine Electro-Acoustical apparatus for over 25 years.”

**Never before such EAR-QUALITY,
such FAITHFUL REPRODUCTION**

Because . . . you and ONLY YOU can decide what sounds best and most pleasing to you . . . see it, HEAR it, compare it with any reproducer anywhere and . . . you be the judge . . . yet, POLYPHASE costs less than ordinary magnetic pickups. And remember, replaceable styli, of course.



**Chromatic Point pressure
may be as low as 2½ grams.**

* Heretofore, in demonstrations it was necessary to place the reproducer and turntable in a closet or under a hood to contain the needle-noise.

** See PATHFINDER Magazine editorial, November '51, page 51.

*Write for editorial reprint
on POLYPHASE Principles*

*Be sure to obtain a copy of PHONO FACTS
from your distributor*

MAGNETIC PICKUPS • ARMS FOR STUDIOS & HOMES • HIGH QUALITY CUTTERS • EQUALIZERS, ETC.

* MAGNECORDER

and Performance



..from "On The Spot"..to ON YOUR DIAL!*



"My daddy flies a jet plane over Korea!" . . . Magnecorders "stationed" in southern Japan perfectly recorded these brave, young words for Americans at home to hear! Easy portability and dependable high fidelity make Magnecorders known to Americans serving at home and abroad.

At KRLC, Lewiston, Idaho, Magnecorders bring the same precision and professional quality into the recording room. On an air base or in the studio you can handle "remotes" or delayed programs with complete assurance when you use Magnecorders, the first choice of radio men everywhere.

MORE FEATURES
PT7 accommodates 10 1/2" reels and offers 3 heads, positive timing and pushbutton control. PT7 shown in console is available for portable or rack mount.

GREATER FLEXIBILITY
In rack or console, or in its really portable cases, the Magnecorder will suit every purpose. PT6 is available with 3 speeds (3 3/4", 7 1/2", 15") if preferred.

HIGHER FIDELITY
Lifelike tone quality, low distortion, meet N.A.B. standards — and at a moderate price. PT63 shown in rack mount offers 3 heads to erase, record and play back to monitor from the tape while recording.



WRITE FOR NEW CATALOG
Magnecord, INC.

360 North Michigan Avenue
Chicago 1, Illinois, Dept. A-1

Send me latest catalog of Magnecord equipment.

Name.....
Address.....
City.....Zone.....State.....



typical badly done monaural miking. Lacked presence. Suddenly, though, the operator, realizing the mistake, cut in the other channel. The effect was astonishing. Instantly the distant chorus was on top of you, around you, everywhere, full and deep and in perspective. I have never heard such a reproduction of sound in my life as that chorus recording, and remember it was *via speakers*. The liveness of the single mike had been way off—too distant, too thin and confused. But from the *same spot* the two channels brought the whole into perspective and naturalness, exactly as listening with two "live" ears at that exact spot. What more could we hope for? Moral: Dual-channel miking is going to relate itself to actual on-the-spot listening conditions, as stereo photography relates to on-the-spot seeing. And this in spite of false phasing, mixed-up directions, overlapping, and the rest that is inherent in two-speaker reproduction. Try it yourself and see.

5. Some interim conclusions from all this:

(a) Dual channel recording via tape will prove far more practical, in terms of more realistic reproduction, than you may have surmised. It works, even if slightly crazily.
(b) Dual miking will follow rules for two-eared normal hearing rather than present traditional monaural techniques. That means a total re-valuation of mike set-up. It means drastic experimenting. Concerts from concert seats. Mikes at a great distance. Pickups of confused group-sounds that would be jargon in conventional recording. Pickups in hitherto wholly unfavorable acoustic conditions. Rule of thumb—what sounds good to two ears will sound good to two mikes.

No more close-up stuff (necessary for monaural distinctness and proper liveness); probably far less need for multi-mike set-ups on one channel.

(c) I suspect a simple rule will show up: *the liveness in a given room will be a fixed factor* though directional and balance factors will change with mike location. Maybe I'm wrong here—we'll see. If I'm right, finding the right mike spot won't be a matter of finding the right liveness, as it is mostly now, but instead will depend on loudness and perspective balance. How loud, how near. Liveness will stay put, wherever you set up. That ought to be something!

(d) As in normal hearing, dual-channel liveness tolerance, over a range of acoustical conditions, will be enormously greater than with monaural pickup. That means that "almost any old place" will do for recording. The listening ear will accept as "natural" a far wider range of variance in all factors. Recording should consequently be both more flexible and far easier.

(e) Judging from the few tapes demonstrated by Magnecorder, a close-together mike set-up, not over 20 inches, gives the most natural, realistic sense of presence; whereas a wide spacing—up to 20 feet—gives the most pronounced directional effect.

Direction—or realism?

Now that's a vital point. Are we after direction, or do we want realism? Experimenters haven't made themselves clear at all on this point in the past. Much ado has been made about trumpets on the right, people walking across stages, etc. Direction. I'm quite clear. I don't mind direction, but I want *realism* in the over-all sound. Moreover, I've discovered that even with false direction, realism is improved via two channels.

[Continued on page 40]

New 1952 HEATHKITS

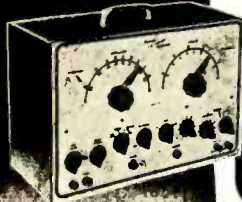

Heathkit TELEVISION GEN. KIT \$39.50



Heathkit ELECTRONIC SWITCH KIT \$19.50



Heathkit AUDIO GEN. KIT \$34.50



Heathkit CONDENSER CHECKER KIT \$19.50



Heathkit R. F. SIGNAL GEN. KIT \$19.50



Heathkit A.C. VOLTMETER KIT \$29.50



Heathkit SQUARE WAVE GEN. KIT \$29.50



Heathkit INTERMODULATION ANALYZER KIT \$39.50



Heathkit AUDIO FREQ. METER KIT \$34.50

Heathkit 5" OSCILLOSCOPE KIT

- New "spot shape" control for spot adjustment — to give really sharp focusing.
- A total of ten tubes including CR tube and five miniatures.
- Cascaded vertical amplifiers followed by phase splitter and balanced push-pull deflection amplifiers.
- Greatly reduced retrocure time.
- Step attenuated — frequency compensated — cathode follower vertical input.
- Low impedance vertical gain control for minimum distortion.
- New mounting of phase splitter and deflection amplifier tubes near CR tube base.
- Greatly simplified wiring layout.
- Increased frequency response — useful to 5 MC.
- Tremendous sensitivity .03 RMS per inch Vertical .6V RMS per inch Hor.
- Dual control in-vernier sweep frequency circuit — smoother acting.
- Positive or negative peak internal synchronization.
- Multivibrator type Wide Range Sweep Generator.

A brand new 1952 Heathkit Oscilloscope Kit with a multitude of outstanding features and really excellent performance. A scope you'll truly like and certainly want to own.

The kit is complete with all parts including all tubes, power transformer, punched and formed chassis, etc. Detailed instruction manual makes assembly simple and clear — contains step-by-step instructions, pictorials, diagrams, schematic, circuit description and uses of scope. A truly outstanding value.

MODEL O-7
SHIPPING WT. 24 LBS.

\$43.50

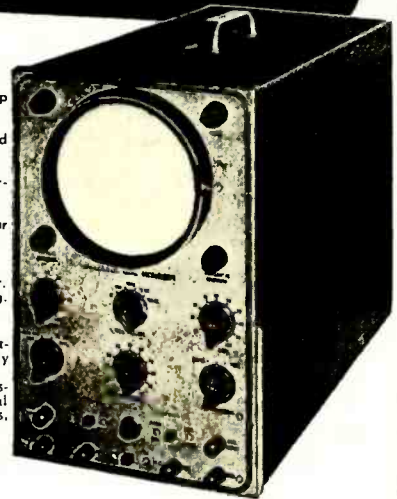

Heathkit VACUUM TUBE VOLTMETER KIT

- New styling — formid case for beauty.
- New truly compact size — Cabinet 4 1/8" deep x 4-1/16" wide x 7 3/8" high.
- Quality Simpson 200 microamp meter.
- New ohms battery holding clamp and spring clip — assurance of good electrical contact.
- Highest quality precision resistors in multiplier circuit.
- Calibrates on both AC and DC for maximum accuracy.
- Terrific coverage — Reads from 1/2V to 1000V AC, 1/2V to 1000V DC, and .J to over 1 billion ohms resistance.
- Large, clearly marked meter scales indicate ohms, AC Volts, DC Volts, and DB — has zero set mark for FM alignment.
- New styling presents attractive and professional appearance.

The 1952 Model Heathkit Vacuum Tube Voltmeter! Newly designed cabinet combines style and beauty with compactness. Greatly reduced size to occupy a minimum of space on your work-bench. Covers a tremendous range of measurements and is easy to use. Uses only quality components including 1% precision resistors in multiplier circuit for greatest accuracy. Simpson 200 microamp meter with easy to read scales for fast and sure readings.

All parts come right with kit, and complete instruction manual makes assembly a cinch.

MODEL V-5
SHIPPING WT. 5 LBS.



\$24.50

YOU SAVE BY ORDERING DIRECT FROM MANUFACTURER

EXPORT AGENT
ROCKE INTERNATIONAL CORP.
13 E. 40th ST.
NEW YORK CITY (16)
CABLE: ARKAN N.Y.

The **HEATH COMPANY**

... BENTON HARBOR 25, MICHIGAN

NEW PRODUCTS

• **Magnetic Tape Recorder.** Many advanced features, both mechanical and electrical, are inherent in the new Concertone Type NWR-1 tape recorder, recently placed on the market by Berlant Associates, 4917 W. Jefferson Blvd., Los Angeles 16, Calif. Designed expressly for broadcast and recording studios and for industrial installations, the new model stresses simplicity and ruggedness of construction. Elimination of drive belts, clutches, and idlers, and the inclusion of a newly-developed self-adjusting disc braking sys-



tem, greatly reduces maintenance problems. Operation is fully automatic by means of single interlocked push-button control of each function. Remote control units available as standard accessory. The NWR-1 may be equipped with many as five heads, thereby affording, in addition to standard operation, such diverse functions as multi-channel recording, simultaneous playback of one program and recording of another, stereophonic recording, and pulse synchronization for motion picture work. Choice of 7.5-in. or 15-in. recording speed is afforded by means of electrical switch which also adjusts equalization to maintain flat response. Designated the Network Recorder, the NWR-1 is made up of three separate panel-mounted assemblies—drive mechanism, amplifier, and 4-position microphone mixer—all of which may be purchased in portable carrying cases or for mounting on standard 19-in. rack. Frequency response of the NWR-1 is within ± 2 db from 40 to 15,000 cps at 15 in./sec. Signal-to-noise ratio is 55 db, and harmonic distortion is 2 per cent at zero VU. Descriptive literature and prices will be mailed upon request to the manufacturer.

• **Portable Level Indicator.** Ruggedness of a field instrument is combined with laboratory accuracy in the new Series 911 volume level indicator recently introduced by the Daven Company, 131 Central Ave., Newark 4, N. J. Designed for the precise measurement of audio levels in broadcasting, recording, and allied fields, the 911 is entirely self-contained, requiring no batteries or external power supply. Indicating meter is of the copper-oxide type, with scale calibrated in both VU and percentage. Two controls are provided, one a small screw-driver ad-



justment for zero level setting, the other a constant impedance T-type network for extending the instrument range in 2-db steps. Over-all dimensions are $11 \times 6 \times 6\frac{1}{4}$ in. and net weight is only $5\frac{1}{2}$ lbs. Complete details will be supplied on request.

• **Diamond-Sapphire Stylus.** Record-playing pattern of most collectors governed the design of the new GE Model RPJ 013 stylus, recently announced for use with GE Model RPX 047 and RPX 050 variable-reluctance cartridges. Studies showing that LP's account for considerably more playing than 78's, are reflected in the fact



that the new dual stylus contains a diamond for the former and a sapphire for the latter. A simple twist of the positioning knob on the cartridge brings into playing position either the diamond or the sapphire. The "double twist" feature of the GE "baton" type stylus has been incorporated in the RPJ 013. Immediate delivery is available and descriptive literature is in the hands of GE distributors.

• **Unique Tape Recorder.** Although similar fundamentally to standard magnetic tape recorders, the new Ampex Model 307 is designed especially for recording signals telemetered from missiles and aircraft. Frequency range of the 307 is 100 to 100,000 cps, which covers all FM/FM telemetering channels recommended by the Telemetering Panel of the Research



and Development Board. Recording speeds are 60, 30, and 15 in./sec. Because of its unusual frequency coverage, the 307 is useful for recording many types of data which heretofore could be recorded only by means of an oscilloscope and moving-film camera. Manufactured by Ampex Electric Corporation, Redwood City, Calif.

• **Portable Mixer.** Although small in size and light in weight, the New Altec Lansing Model 220A 4-position mixer affords a standard of audio performance which suits it for even the most demanding of broadcast or recording applications. Designed primarily for field use, the compact unit incorporates two dual pream-

plifiers with individual controls for four microphone inputs, a line amplifier, master gain control, built-in power supply, and a 4-in. illuminated VU meter. Provision is made for operation from external batteries where a.c. power is not accessible. Available input impedances are 30, 150/250, or 500/600 ohms, and choice of



either 150 or 600 ohms output impedance is provided by means of selector switch. Gain is 80 db with maximum output level of +18 dbm at less than 1.0 per cent harmonic distortion. Frequency response is within ± 1 db from 30 to 15,000 cps. Dimensions are $23 \times 6 \times 12$ in. and complete weight is 27 lbs. Distributed by Graybar, the 220A is manufactured by Altec Lansing Corporation, 9356 Santa Monica Blvd., Beverly Hills, Calif.

• **Juke Box Analyzer.** Developed as a trouble shooter for disabled coin-operated phonographs, the "Master Analyzer," recently announced by AMI Inc., Grand Rapids, Mich., permits factory inspection and repair methods in the field. Among the components which can be serviced

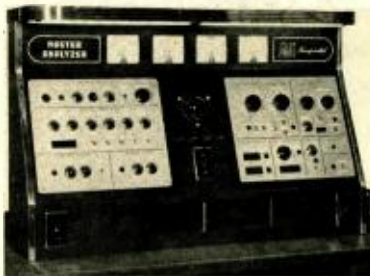

with the device are junction boxes, record-rack assemblies, switches, wall boxes, selector assemblies, and record-changing mechanisms. Although the analyzer is a stationary instrument, it contains elements for simulating actual operating conditions found in various specific locations. Wall boxes, for example, can be tested and adjusted for operation under the extremes of voltage which prevail at the point of usage.

• **Tiny Thermal Delay Relay.** The new Model 207 recently introduced by the Instrument Division of Thomas A. Edison, Inc., West Orange, N. J. provides protection for most any type of electronic

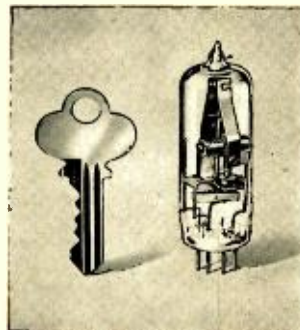

circuit. Weighing but one-half ounce, and sealed in a T-5 $\frac{1}{2}$ glass envelope with a 7-pin base, the 207 is available with delays ranging from 5 to 120 seconds and various heater voltages.

The Discriminating Eventually Come to Leonard's

You . . . and Music as the Masters Played It!

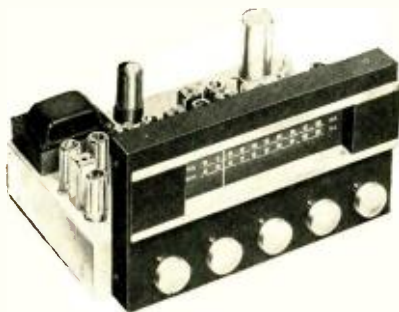

THE RADIO CRAFTSMEN FM-AM TUNER MODEL C-10

Designed and engineered for the music lover, this superb FM-AM tuner is now recognized as being one of the best in the field. Built-in pre-amplifier can be switched for use with GE, Pickering or Crystal phono cartridges. Four controls: Bass, Off-On-Volume, FM-AM-TV-PH selector, Tuning, and Treble. Automatic Frequency Control eliminates entirely the annoyance of station drift.

NET \$131.50

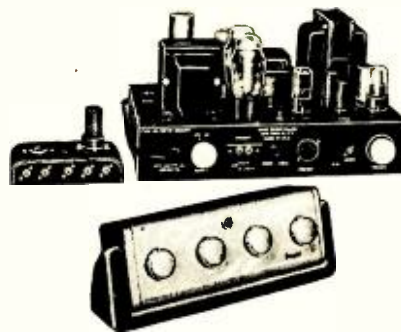

THE *Bogen* BATON

Here, truly, is an instrument of unique quality, appearance and performance. Combining superior technical characteristics and overall balance which distinguishes the true high fidelity amplifier, the Bogen Baton is an all Triode amplifier delivering 10 watts at three-tenths percent distortion! Frequency Response—flat from 10 to 50,000 cycles. Inputs—AM, FM, TV and all popular phono cartridges.

NET \$147.14



GARRARD "TRIUMPH" RECORD CHANGER MODEL RC-80

Completely automatic, this superb three speed record changer plays every type of record exactly as the manufacturers intended. Heavy-duty constant speed motor assures quiet performance—without "wows". Heavy professional-type turntable "bearing balanced". You need not lift records over spindle when removing them from turntable—simply remove spindle from socket. Records may then be taken off turntable WITHOUT DAMAGE to record. Pick-up Arm is specially designed to eliminate resonance. Plug-in type heads for both standard and microgroove recordings. Automatic shut-off. Special heavy-duty spindle for 45 rpm discs. Dimensions—15 1/2" W x 13 1/2" D x 5 1/2" H.

NET \$39.00



WESTERN ELECTRIC LOUDSPEAKER MODEL 728B

Developed by the Bell Telephone Laboratories, this 12" loudspeaker represents an advanced application of the latest techniques and is a result of expensive research and development in the interests of natural reproduction of sound. While some loudspeakers have been described as having "presence," the 728B has what might be described as an "emotional" characteristic which eliminates the consciousness that the program is coming through a loudspeaker. It is intended for high quality reproduction of sound, for radio monitoring of speech and music, and for musical reproduction and public address systems. Now being offered to the public at 1/3 its original price! Frequency Response—60 to 10,000 cps. Power Rating—30 watts. Impedance—4 ohms.

NET \$35.70

Winner of PEN-TRON 9T-3C contest held at the AUDIO FAIR: Mr. Jaime Caro of 141 No. High Street, Mt. Vernon, N. Y. Number of beans in jar — 12,943. Mr. Caro's guess—12,960

CORTLANDT 7-6563

Leonard Radio inc.

the house
built on
SERVICE

69 CORTLANDT ST., NEW YORK 7, N. Y.

Write for
our
Hi-Fi
Catalogue

HARVEY OFFERS YOU QUALITY UNITS FOR YOUR SPEAKER INSTALLATIONS

STEPHENS COAXIAL 2-WAY SPEAKER



A compact assembly combining a cone-type, low-resonant low-frequency unit with multi-cellular type, wide-angle high-frequency dispersion. Recommended for broadcast monitoring, motion picture sound, and—especially—FM and record reproduction. Power rating—20 watts. Impedance—16 ohms. Frequency response—40 to 12,000 cps. Diameter—1 1/2". Depth—10 1/2". Weight—30 lbs.

No. 106AX\$124.50

PERMOFLUX CORNER BAFFLE



**EFFICIENT
ATTRACTIVE
LOW PRICED**

Designed for use in almost any room of the house, this 4-layer plywood cabinet improves the performance of any 8-inch speaker. Finished in rich mahogany teak-erette, it measures 24 in. high, 14 in. wide and is 9 1/2 in. deep at top and 13 3/4 in. at bottom. Weight, less speaker is 21 lbs.

No. CB-8-M\$39.00

PERMOFLUX MONAURAL HEADPHONES



Capable of reproducing full orchestral scale within range of average human hearing. Compact, light weight. Finger-tip adjustment for proper fit.

No. DHS-17 As illustrated with No. 1505 Ear Cushions\$45.00

New! JIM LANSING SPEAKER SYSTEM



FEATURING UNIFORM SOUND WAVE DISTRIBUTION OVER THE ENTIRE AUDIO RANGE.

Designed specifically for the music lover who wants accurate and undistorted sound reproduction—this system incorporates a new, improved acoustical lens and 2-15" woofer speakers in conjunction with a crossover network. Housed in attractive corner cabinet.

No. D1004 in dark mahogany.....\$390.00
No. D1005 in blonde finish.....\$396.00

PERMOFLUX ROYAL EIGHT"



8-inch Speaker offers big-speaker performance in a small frame.

No. 8T-8-1 Low Priced at\$13.50

CABINART HORN LOADED CORNER BAFFLE IN KIT FORM



Constructed of 5-layer, 1/2" thick selected plywood. Completely sanded and ready for finishing. Kit includes grille cloth, mounting hardware, glue, etc....

Easy-to-follow instructions for simple and rapid assembly.
Kit for 12" speaker.....\$19.95
Kit for 15" speaker.....\$23.95

HARVEY STILL HAS AVAILABLE

Altec 604B Speakers
Electro Voice, Lansing Stephens
Western Electric 755A Speakers
others, etc.

In fact, we have almost all of the better grade speakers at the right prices. All with Alnico 5 PM Fields. Come in now, or order by mail... get your quality speaker while it is still available.

Telephone **hrc** LUxemburg 2-1500

HARVEY

RADIO COMPANY, INC.

103 West 43rd St., New York 18, N. Y.

NOTE: In view of the rapidly changing market conditions, all prices shown are subject to change without notice and are Net, F.O.B., N.Y.C.

VOLUME CONTROLS

[from page 14]

miniature version of the much louder 80 db average condition. This lower listening level means reproduction at only about one-thousandth of the average power required for the 80 db reference level.

As has been shown, the human hearing system is generally non-linear in amplitude response, even at a fixed frequency such as 1000 cps. For that reason, the relative response curves of Fig. 4 cannot be used to compute the needed compensation for low-level reproduction, and we must go back to Figs. 2 and 3. The Fletcher-Munson contours of equal loudness show relative loudness only, as already mentioned, but may also be used to determine relative attenuation by subtracting other curve values from the reference level (80 db) curve. The compensation determined in this way or from Figs. 2 and 3 is shown in relative attenuation form in Fig. 5. To illustrate the derivation of the curves of Fig. 5, assume that proper 50 cps compensation is desired at 30 db below the reference level of 80 db, i.e., at 50 db sound pressure. The 1000 cps loudness sensation for 80 db sound pressure in Fig. 2 is 87 db, while the 50 cps response is 76 db or 11 db below the 1000 cps response. At 50 db sound pressure, the 1000 cps loudness is 67 db and the 50 cps loudness sensation should again be 11 db lower, or 56 db. However, it takes about 70 db sound pressure to make 50 cps sound this loud, so that 50 cps reproduction should be attenuated only 10 db when 1000 cps reproduction is attenuated 30 db.

Variations of one db or less have been ignored in plotting Fig. 5. The family of curves shows that only very minor compensation is needed for frequencies above 1000 cps. This is a fortunate state of affairs, for it makes possible inclusion of overall fixed high-frequency compensation to correct, at least partially, for deficiencies of the loudspeaker and other units in the system. The best location for both low- and high-frequency compensating circuits will generally be at some point in the amplifier element of the system.

Interstage Bass-compensation Circuits

The slope of the low-frequency compensation shown in Fig. 5 is roughly 2 db per octave at 10 db reduction in 1000 cps amplification, about 4 db per octave at 20 db reduction, about 6 db at 30 db, and about 7 db at 40 db. This means that a simple one-section RC network is inherently capable of fairly good compensation from 0 to about 30 db below the maximum gain reference level. Such a network (C_2R_2) is shown in Fig. 6. The values of the various resistors and capacitors in this circuit may be proportioned so as to approach the desired frequency-response variations shown in Fig. 5 with adjustment of the resistance of R_2 . The series impedance of C_2R_2 at

1000 cps must be much lower than the maximum value of the bass control R_2 (1 megohm), by a factor of at least 20 to 1. However, this compensator works not by "boosting" the lower frequencies but by attenuating the middle and high frequencies. A considerable volume con-

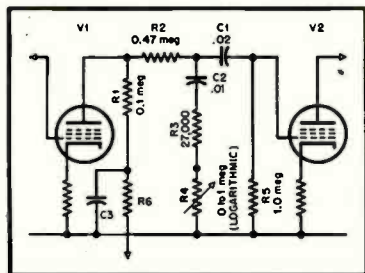

Fig. 6. Interstage bass-compensation circuit.

trol effect will therefore be produced when R_4 is adjusted because the frequencies affected include the middle range which determines apparent loudness. R_4 thus functions as a composite bass-and-volume control. Such combination is desirable but open, in this case, to the usual objections to an audio interstage gain control plus the shortcoming of insufficient range of attenuation. The presence of R_2 is beneficial in that it prevents the a.c./d.c. load ratio for V_1 from varying seriously with adjustment of R_4 . Components R_2, C_1 are the usual elements of a plate-circuit isolation filter for V_1 .

(To be concluded)

AUDIO PATENTS

[from page 4]

and R_c . Expressions are derived in the patent for high- and low-frequency gain and by equating the two a value can be found for R_c which will keep the gain constant at all frequencies up to the upper limit.

If C_k , which up to this point is not needed, is omitted, an appreciable portion of the very-high-frequency plate current will pass through C_1 and any cathode impedance to the cathode. Degeneration from this source is reduced by including C_k to bypass the cathode at these frequencies. With a value of 10 μf for C_1 and with the values shown in Fig. 3, response at 2 mc is about 70 per cent of the midband response.

Aid for Censors

During the last war, many radio stations employed censors whose task it was to monitor transmissions constantly and cut off the program whenever some kind of *verboten* information crept into the material. Listeners were sometimes very much startled to find a speaker cut off in the middle of a word, and censoring was never as effective as it could have been because before the censor could act, enough of the information had to be transmitted to let the censor know he should do something.

Edward F. Hogan of Andover, Mass., has provided in his Patent No. 2,561,698 a simple solution, illustrated in Fig. 4. It is a continuous-loop magnetic recorder with record, playback, and erase heads as shown.

SHALLCROSS

PRECISION-BUILT ROTARY SWITCHES

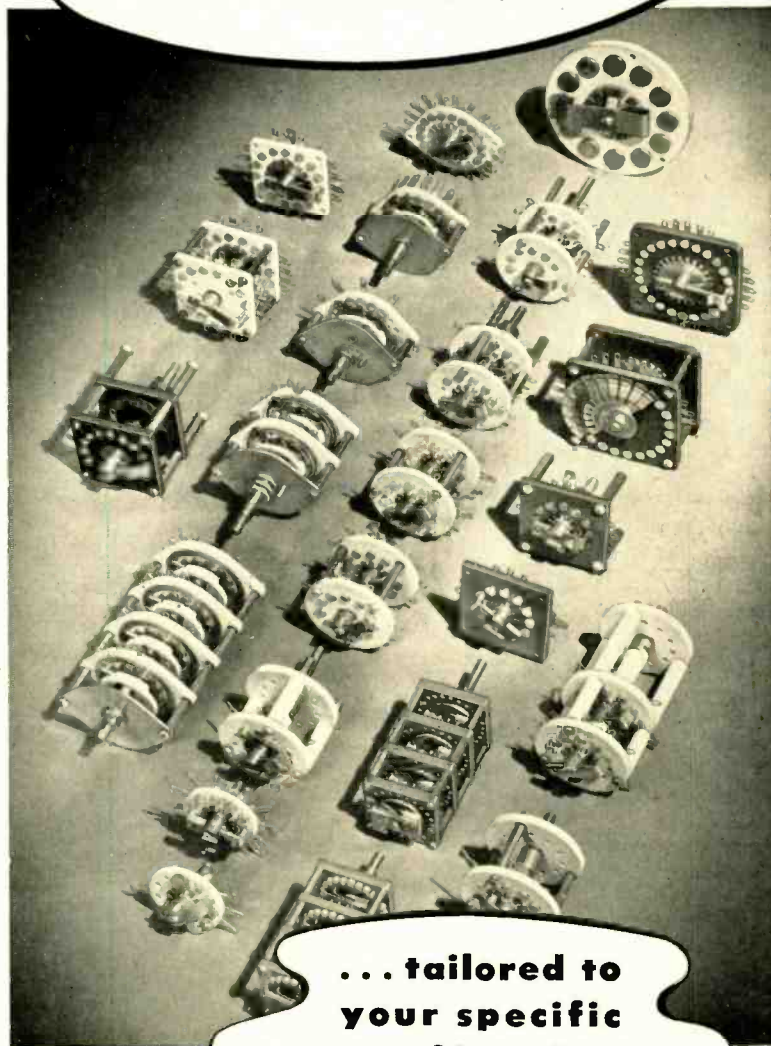

... tailored to
your specific
application

Dozens of standard basic switch plates, each subject to numerous adaptations, enable Shallcross to supply switches that are exactly suited, for your job. Single or multi-deck types having up to 60 non-shorting positions are regularly produced.

Contact resistance less than 0.001 ohm is a feature of many types. Silver contacts, steatite insulation are standard for 11, 15, and 18 position switches. Paper, nylon, and linen base phenolics and glass melomine insulation are available where required. Write for information.

SHALLCROSS MANUFACTURING COMPANY

Electronic Designer • Engineers • Manufacturers

Collingdale, Pa.

Microphones

BY TURNER
QUALITY that speaks for itself

in every sound application

The Aristocrat Model 50D

The world's finest dynamic. For TV, FM, AM. Recording, public address and broadcast. Laboratory calibrated. No closely associated auxiliary equipment required.

Response: 50 - 15,000 c.p.s. flat within $\pm 2\frac{1}{2}$ db.
Level: 56 db below 1 volt/dyne/sq.cm. at high impedance.

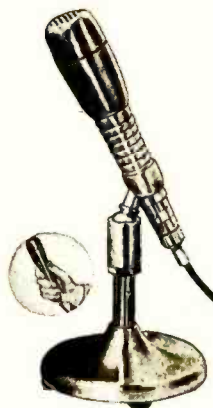

Model 60X

A new low priced crystal desk and hand microphone for economical recording and sound systems, amateurs, dictation machines.

Response: 70 - 7000 c.p.s.
Level: 52 db below 1 volt/dyne/sq.cm.



The Dependable 33X-33D

A general purpose microphone that offers high quality performance at medium cost.

Model 33X Crystal

Response: 50 - 9000 c.p.s.
Level: 52 db below 1 volt/dyne/sq.cm.

Model 33D Dynamic

Response: 30 - 9000 c.p.s.
Level: 54 db below 1 volt/dyne/sq.cm. at high impedance.



The Professional Model U9S Dynamic

A rugged reliable microphone. 4 impedances at your fingertips. A smooth performer at all impedances and frequencies.

Response: 40 - 9000 c.p.s.
Level: 52 db below 1 volt/dyne/sq.cm. at high impedance.



THE TURNER COMPANY

929 17th Street N.E. Cedar Rapids, Iowa

In Canada:

Canadian Marconi Company, Toronto, Ontario and Branches

Export:

Ad. Auriema, Inc., 89 Broad Street, New York 4, N.Y.

Crystals licensed under patents of the Brush Development Company



The studio output goes into the record head and the censor's monitor headset or speaker is also normally across the studio channel. The output of the playback head is fed to the transmitter's audio circuits, so that the studio output undergoes a short delay before going on the air.

The censor can catch a forbidden topic and prevent it from going on the air by

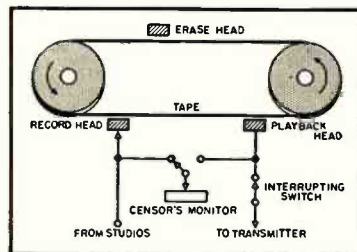

Fig. 4

interrupting the playback circuit during the delay time. By switching his monitor between record and playback points he can cut the transmission at the end of a sentence and restore it at the correct point to lend more smoothness to the whole process. And, more important, he can stop even the first word of forbidden material from appearing on the air.

SMOOTH RESPONSE

[from page 15]

others of similar characteristics. Larger models can be used, if desired, with probable improvement in low-frequency reproduction.

TABLE I

Volume cu. ft.	Side of Triangle inches
2	39
3	44½
4	49
5	53
6	56¼

BASS SPEAKER

[from page 22]

Junior complained of the loss of his slide, while father missed his bass, and pondered how he could build a bass horn into the house. There seemed to be only one answer, to build a house around the horn.

An architect was consulted, and it seems that houses cost from twelve dollars per square foot up. It didn't seem economical to use floor space for a horn, so why not place it in the attic and enter the room in a corner so that the walls and ceiling became the extended portion of the mouth. While at it, why not extend the range down another octave or so, and really leave nothing undesired? Consideration was given to the Hypex formula versus the exponential. It seems that when the Hypex horn cuts off, it

really cuts off, so we stayed with the exponential and increased the area 15.6 per cent for every six inches of axis. This gives a 26-cps cut-off. Figure 1 shows the result of much sawing, planing, and gluing. The throat is actually octagonal in shape, the corners of the square being filled in with triangular shaped pieces which are tapered to give the exponential expansion to the cross-sectional area. The section that connects to the room measures 4 ft. x 4 ft. x 5.65 ft. The axis curves into the room and the expansion of the walls and ceilings very nearly matches the horn for an axial distance of some five feet, at which distance, the cross-sectional area of the horn is triangular, having three equal sides approximately 11 ft. 6 in. each. This is best seen in Fig. 2, while Fig. 3 shows the various sections of the horn during construction.

This point is the virtual horn mouth and has an area of some 65 square feet, which is sufficient for a cut-off frequency of 26 cycles. The horn actually does not stop here, but the expansion is no longer at an exponential rate. Hence, reflections occur at this point as well as at the boundaries of the room.

One lot, six months and several headaches later the house took shape around the horn. It was placed in the far corner of the library which is connected to the living-room by double doors. Facing the living-room, and mounted flush in the wall are the middle-range speaker and the high-frequency speaker; the former consists of a Western Electric 555 driver unit, connected to a straight exponential horn, and the latter is a Smith-Selsted high-frequency speaker.²

Recessing these units was made possible by furring down over the bathtub in the adjoining room. The entire library thus becomes part of the bass horn and mixing chamber, while the listening area is in the living-room. The cross-over networks were designed for 400 and 5000 cps respectively. Variable pads were inserted in the middle- and high-frequency channels so that the relative levels could be adjusted.

Came the big moment when we turned the switch and music flooded the house—definitely up to our expectations—and now for the criticism of those who had stood by during the months of labor it took to launch our brain-child. The first week, some fifty enthusiasts and friends came to "give a listen." The extended range and cleanness of reproduction was apparent to all and doubly so to those who brought along their pet records. Some, accustomed to "Juke Box" bass, inquired, "Where is the bass?" On further listening to such fine recordings as Columbia's LP of Saint-Saens' Symphony No. 3 in C Minor, they realized the full, beautiful, bass organ tones were there without the usual distortion, hang-over effects and indistinguishably muddled bass. Others expressed their views

² B. H. Smith and W. T. Selsted, "A loudspeaker for the range from 5 to 20 kc," AUDIO ENGINEERING, Jan. 1950, p. 16.

For Matchless Performance—Use

CHICAGO

MATCHED

Power Transformers & Filter Reactors

Optimum performance is no accident. CHICAGO transformers insure optimum performance, first by advanced design geared to today's electronic tubes and circuits, second by famous Sealed-in-Steel construction, and third by matching associated units to perfection.

Electronic designers, engineers, experimenters and builders are fast learning about CHICAGO advantages. There's proof in the increasing preference for Sealed-in-Steel power units. They're exactly suited to requirements—one range of ratings specifically designed for capacitor input, another for reactor input. Filter reactors are perfectly matched to power transformer units both in rating and construction characteristics. For a complete range of matching units, designed for matchless performance, you'll want to refer to the CHICAGO New Equipment Line Catalog. Send for your copy today.



Full Frequency Range Audio Transformers

within $\pm \frac{1}{2}$ db
30-15,000 cycles

For uniformly low distortion, for response curves that are truly flat over the full frequency range, use these famous CHICAGO Sealed-in-Steel input and output units. Get the facts on the BO-6 (P-P 6L6's to 6/8 or 16/20 ohm speaker), the BO-7 (600/150 ohm line to 6/8 or 16/20 ohm speaker), and the full line of CHICAGO full frequency units—years ahead in audio transformer design—tops for performance.



Public Address Range Audio Transformers

within $\pm \frac{1}{2}$ db
50-10,000 cycles

CHICAGO P.A. range units are geared to today's public address circuit requirements and to latest tube types. Line and voice impedances used in the advanced Sealed-in-Steel output designs meet RMA standards. The 4, 8, and 16-ohm voice coil impedances can also be used with 3.2, 6 and 20-ohm speakers without appreciable mismatch. Available in a complete range of perfectly matched driver and output units.



SEND FOR FREE NEW EQUIPMENT LINE CATALOG

You'll want the full details on CHICAGO'S New Equipment Line—the famous Sealed-in-Steel line that offers advanced engineering design to fit today's circuits. Lists units for all purposes: Power, Bias, Filament, Filter Reactor, Audio (in 3 frequency ranges), JAN-T-27, Modulation, Stepdown and Isolation, High Q, Splitter, Low Pass. Write for your FREE catalog today—or get a copy from your distributor.

CHICAGO TRANSFORMER

DIVISION OF ESSEX WIRE CORPORATION

3501 ADDISON STREET • CHICAGO 18, ILLINOIS



on the marvelous presence of the system, glancing up from time to time in the direction of the speakers as though half expecting to see the orchestra or performing artist.

The best recording we have from a technical standpoint is one taken live, on tape, of a symphony orchestra. The recording was made at the fifteen-inch per second speed, and one of the new miniature high-quality condenser microphones was used for the pick-up. The gain was set for full track on the loudest portions, and no monitoring was done. This recording has a quality and dynamic range when reproduced on our horn system that led one engineer to remark, "This is the first time I ever heard recorded music that sent thrills up and down my spine!"

THEATRE VIDEO

[from page 17]

Supply, Control Panel, and Optical Barrel, provides instantaneous direct projection of images as received on a direct view television tube.

The design of the entire optical system—which is shown in Fig. 5, and which consists of cathode ray tube, reflecting mirror, and corrector plate—is controlled by the cathode ray tube. For good focus over the entire picture area it is essential that the curve of the mirror be concentric with the curve of the tube face, and that the tube face be located approximately at the focal point of the

mirror. The system has a focal length equal to the radius of curvature of the tube face.

These optical qualifications result in a fixed focal length and a single value of magnification for any chosen throw distance. Thus picture size at a fixed throw distance can be changed only by changing the size of the picture on the cathode ray tube. This may result in clipped pictures or poor resolution, but a variation of about 10 per cent either way in picture dimension is feasible. The preferred throw distance of the Simplex system is 62 feet, providing a picture 15 feet high by 20 feet wide.

The corrector plate is a precision unit achieving a high standard of picture resolution. Light distribution is balanced over the entire screen, without "hot spot" center glare.

Operation of the Simplex system is virtually as simple as tuning a home television set. Accurate metering circuits in the projection booth show when the

Presenting

GOODMANS

HIGH FIDELITY - 12" P.M.

TWIN CONE AXIOM 150

\$65.00 LIST

This 12-in. high fidelity unit has a twin-curvilinear diaphragm (British patent No. 451754). A carefully designed magnet assembly using anisotropic material provides a total flux of 158,000 maxwells on a 1½-in. pole. The back centering device is a dustproof bakelised linen disk with concentric corrugations. The combination of these features gives this precision-built instrument an outstandingly wide coverage from 40 to 15,000 c.p.s. free from bass modulation effects. An ideal high fidelity reproducer for the record enthusiast and the connoisseur of wide range musical reproduction, it gives exceptionally fine transient and frequency response.

U. S. NATIONAL SALES
WILLGOLD ELECTRONICS SALES CORP.

350 Fifth Avenue, New York, N. Y.

New England Office
Harold A. Chamberlin
31 Milk St., Boston 9, Mass.

Pacific Coast Office
Perlmuth-Colman & Associates, Inc.
1335 Flower St., Los Angeles, Calif.

Chicago Office
Harry Halinton Co.
612 N. Mich. Ave., Chicago 11, Ill.

Canadian Office
A. C. Simmonds & Sons, Ltd.
100 Merton St., Toronto 12, Can.

Manufactured by:

GOODMANS INDUSTRIES LIMITED
WEMBLEY MIDDLESEX ENGLAND

SPECIFICATION

Frequency Coverage
40/15,000 c.p.s.

Overall Diameter
12 in.-31.3 cms.

Overall Depth
6 in.-17.6 cms.

Fundamental Resonance
55 c.p.s.

Voice Coil Diameter
1¾ in.-4.4 cms.

Voice Coil Impedance
15 ohms at 400 c.p.s.

Maximum Power Cap.
15 Watts Peak A.C.

Flux Density
14,000 gauss

Net Weight
12 lbs. 13 ozs.
(5810 grs.)

Finish—Grey Rivelling Enamel.



Fig. 4. High intensity 16-mm projector which puts a theatre-quality picture on moving picture theatre screens.

most perfect picture is obtained. All circuits are protected by "fail-safe" design: failure of one component will not cause failure or injury to any other component. The unit is protected by a specially designed re-circulation system which cools the optical barrel, making it practically dust-proof, controlling humidity in the barrel, and eliminating arc-over of high voltage.

The system provides for three incoming program channels, each consisting of an audio and a video line. Normally one of these channels will be connected to the receiver included with the equipment. The second will take the incoming program line. The third might be used for a parallel safety channel for the main program line, for an auxiliary microwave receiver, or possibly for a local signal generated by pick-up equipment within the theatre.

The direct-projection type of theatre

TV system is lower in initial cost, and considerably lower in operation and maintenance costs. It is the easiest to operate of the two types, and is highly dependable in performance. When designed and constructed to high standards, it provides high-quality screenings that do not suffer greatly in comparison with theatre quality projection.

Choice of a system for theatre video will depend on the size and type of theatre, its audience and location, its



Fig. 5. The Optical Barrel for use with direct projection from TV receiver.

expected revenue, and its available finances. But one thing is sure: theatre TV in one form or another has already taken hold in many U. S. cities; it has proven its power to pull audiences and to make profits; its ability to outbid major advertisers for exclusive showings of important events has been demonstrated and will increase. Only its final acceptance by the general public as a logical and natural entertainment form remains to be achieved.

TWO PREAMPLIFIERS

[from page 26]

economical design, it is presented because of several other advantages. First, the degrees of compensation for bass and treble correction are continuously variable. Second, bass amplification rises at a 6 db per octave rate to very low frequencies, no matter what turnover point is selected.

A high-frequency roll of 6 db per octave is obtained by loading the pickup with R_1 and R_2 in Fig. 5. The variable resistor should have a log (audio volume control) taper with maximum resistance in full clockwise position. R_1 should be the maximum resistance recommended by the pickup manufacturer for flat response, and R_2 should be one tenth of R_1 . The following values will work well with two magnetic pickups tested:

Pickup	R_1	R_2
Audak	50,000	4,700
G. E.	25,000	2,200
Pickering	15,000	1,500

The continuously variable low-frequency turnover is established by setting R_2 , which is a 0.1 meg log taper control,

NEW ASTATIC CARBON HAND MICROPHONE MODEL 11M5 OFFERS NEW, HIGH SENSITIVITY

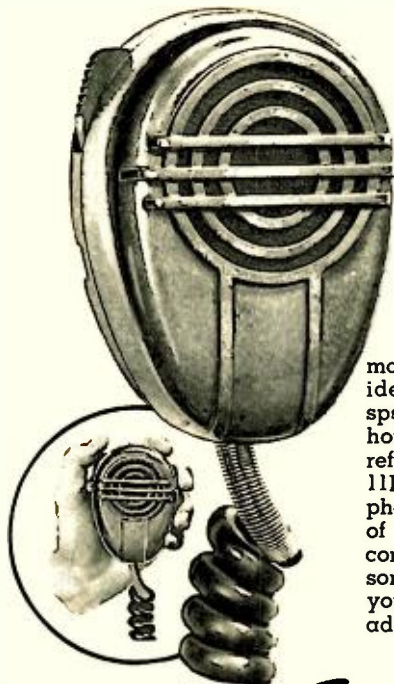

GREAT physical ruggedness and immunity to high temperatures and humidity have long been the claims to fame of carbon microphones. Now you can obtain these important features, PLUS an appreciably increased standard of performance quality, in the newly developed Astatic 11M5 Carbon Hand Microphone. Principally, it is a matter of greater sensitivity and ideal response for maximum speech intelligibility. You will note, however, many other features and refinements that help make the 11M5 the most desirable microphone available for a multitude of hand applications and mobile communications systems. Your personal examination will convince you that here, indeed, is a sizable advance in carbon microphones.

Features

1. New level of ruggedness and performance quality, in a single button carbon microphone.
2. Notably high sensitivity: one volt for 100 microbar signal. (100 ohm load) microbar = 1 dyne/cm². Will work into power output tubes without preamplifier stages, when step-up transformer is used.
3. Ideal response for maximum speech intelligibility: 100 to 4,500 c.p.s. range.
4. Single button carbon element is moisture- and fungus-proofed, to meet exacting military specifications.
5. Rugged die-cast housing finished in grey Hammerlin. Designed for most comfortable, convenient hand use.
6. Double-pole, single-throw switch, with relay and microphone circuits normally open (press-to-talk), can be adapted easily to a wide variety of circuits. Wiring instructions furnished. Positive-acting switch control button operates freely, smoothly, is positioned for ease of thumb operation.
7. Four-conductor, self-coiling cable has oil-resistant Neoprene rubber cover. Retracted length, 12 inches; extended length, five feet. Conductors are color coded and free ends stripped and tinned. Coiled spring cable protector at microphone.
8. Surface mounting wall, panel or dash hang-up bracket furnished. Bracket has anti-rattle prongs that slip on or off button at rear of microphone.



EXPORT DEPARTMENT: 401 Broadway, New York 13, N. Y. Cable Address: ASTATIC, New York

wired for maximum resistance in full clockwise position, in which position the low-frequency turnover is about 400 cps. This method of determining the low-frequency turnover does not actually affect the gain below the turnover point. Rather, the gain above turnover, which remains constant for any given control setting, is decreased, and the turnover frequency is increased. Figure 6 shows this effect much better than words describe it. Figures 7 and 8 show this preamplifier assembled and disassembled. As with the previous unit, the chassis was built from sheet alumi-

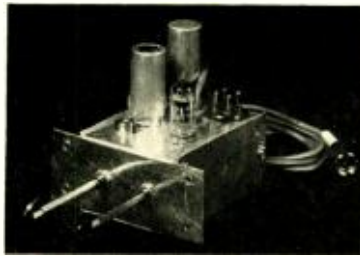

Fig. 7. External view of second preamplifier.

num, although ready made boxes suitable for such work are available. This second preamplifier does have one distinct disadvantage in that a change in the low-frequency turnover setting should be accompanied by an adjustment of the amplifier volume control if the level above the turnover is to be maintained constant. The cathode follower was inserted to provide a low source impedance to the feedback net so that it would not unduly load the amplifier when R_2 was in a counterclockwise position.

The purpose behind both of these designs was to provide a maximum of control, action with a minimum of non-linear elements. Either of these pre-

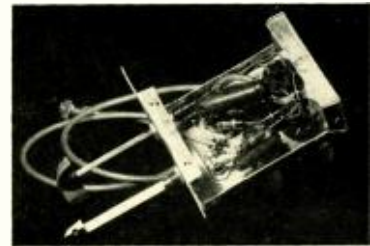

Fig. 8. Chassis wiring of second type of preamplifier.

amplifiers will provide quiet, compact, and effective compensated gain between a magnetic phonograph pickup and an amplifier.

Floating Action!

for all TV Cameras

"BALANCED" TV TRIPOD



This tripod was engineered and designed expressly to meet all video camera requirements.

Previous concepts of gyro and friction type design have been discarded to achieve absolute balance, effortless operation, super-smooth tilt and pan action, dependability, ruggedness & efficiency.

Below:
3 wheel portable dolly with balanced TV Tripod mounted.

Complete 360° pan without ragged or jerky movement is accomplished with effortless control. It is impossible to get anything but perfectly smooth pan and tilt action with the "BALANCED" TV Tripod.

Quick-release pan handle adjustment locks into position desired by operator with no "play" between pan handle and tripod head. Tripod head mechanism is rustproof, completely enclosed, never requires adjustments cleaning or lubrication. Built-in spirit level. Telescoping extension pan handle.



Write for further particulars

CAMERA EQUIPMENT CO.
FRANK C. ZUCKER
1600 BROADWAY NEW YORK CITY

RECORD REVUE

[from page 30]

Let's get this point very clear. Dual channel recording is of use only if it gives a greater flexibility and greater realism to music. Directionality, in the literal sense, is quite secondary. Who cares where the soloist is, if he obviously is *present* and alive. Sounds like a contradiction—but, I ask you, just try two-channel tape for yourself!

(f) Is this binaural or "stereophonic" reproduction? A tricky question, and no space to go into it. Later. 'Nuff to say that we have a compromise, in the two-speaker arrangement and in the miking itself. The compromise ranges over a considerable area of variation, between binaural, with a two-eared "head" and a two-eared reproduction, one channel for each ear alone—and "stereophonic," which merely picks up the sound, say, 20 feet off to the right, and then reproduces same via a loudspeaker, in the same spatial relationship, 20 feet off to the right. You hear it to the right because it is to the right. (Via binaural phones, the direction is a "virtual" image—it *seems* to be in a given direction because of the phasing of the two sounds your two ears are hearing simultaneously.)

The practical two-speaker system will make use of both effects, blended, in ways that aren't going to be easy to evaluate. (I.e. the speaker to your right is to your right. And yet it also is in that position *not* for direction but to make your right ear hear its signal more loudly than the left ear . . . a tricky thing.)

(g) Frankly, I go along with Magnecord for the present in feeling that it really

doesn't matter exactly how all this happens—the thing to do is to listen and judge effects, as good or bad, valuable or not. Work out techniques, and explain 'em later.

Main point to keep in mind. I'd say, is that this new medium for recording, different, related to binaural hearing, still will be basically a matter of achieving *illusions of realism*, just as monaural recording is, right now. There are "tricks" (and formulas for tricks) with monaural mixing; there will be the same for dual-channel work.

But they won't be the same tricks at all. We'll have to start with a cleanish slate. For those who can manage, there'll be a lot of fun in it.

RECORDS

Try these on your hi-fi equipment

(Note: Preferences of readers continue to sway back and forth as to what type treatment is most useful in this space! Here-with a try at a compromise. E.T.C.)

Beethoven, Symphony # 7.

- a. Vienna State Opera, Scherchen
Westminster WL 5089
- b. N. Y. Philharmonic, Walter.
Columbia ML 4414
- c. Amst. Concertgebouw, Kleiber.
London LLP 240

Three top quality recordings technically, the Westminster rather close and intimate, the N. Y. Philharmonic with Walter and London's Kleiber version both big, sharp, live—the last two surprisingly alike in sound. Musically, I'd pick the Walter; Scherchen is close second, but less architectural, less big-style lyricism. The Kleiber is good but not too well rehearsed, not primo. (Toscanini's and Munchi's on RCA are not up to these technically.)

Beethoven, Quartet Op. 59, # 2 in E minor.

- a. Pascal Quartet.
Concert Hall CHS 1206
- b. Vienna Konzerthaus Quartet.
Westminster WL 5098

The Pascals, French trained, do a wonderfully taut, architecturally conceived job, not unlike the Budapests. Recording is on dry side, close-up—excellent of the type. One of a major series of Beethoven quartets by this group. The Konzerthaus Quartet plays in Viennese style—slower, more melodious, more romantically, less architecture. Recording is huge and live, a gratifying but not quite natural sound. (Like numerous other LP's by the group.)

Beethoven, Cantata on Death of Emperor Joseph II. Solos, Vienna Symphony, Akademie Chorus, Klemens Krauss.

Vox PL 6820

A remarkable early work for big orchestra, chorus, soloists, that will be eye-opener for those thinking B. "grew up" only after 1800. Very romantic—much anticipates "Fidelio." A fine performance and top quality recording.

Beethoven, Grosse Fuge, Op. 133; Purcell, London Chaconne, Three-part Fantasias.

Vienna Chamber String Orch., Litschauer.
Vanguard VRS 419

A remarkable feat of virtuoso playing—the difficult Great Fugue, originally for string quartet (and almost impossible there), is played here without a blob or a burble by a string orchestra. Fine string recording, and the Purcell items on the reverse make up in smoothness for Beethoven's rocky musical terrain.

Beethoven, Piano Concerto # 4.

Rubinstein; Royal Philharmonic, Beecham.

RCA Victor LCT 1032

A "reissue" of a post-war 78 on collector's label. Presumably it was disc-made; it lacks highs. This one was never issued here as 78. Not a bad recording at all, with R. at his best—

TERMINAL
OFFERS THIS GREAT VALUE
IN THE FULL RANGE, VERSATILE

BRILLIANTLY
ENGINEERED

PRECISION
BUILT

Concertone
MAGNETIC TAPE RECORDER
BROADCAST STUDIO
QUALITY



No. 1401

Concertone
MAGNETIC
TAPE RECORDER

\$345⁰⁰ Net
LESS TRAY
F.O.B. N.Y.

A precision built and thoroughly tested instrument, capable of recording the full range of audible sound with full dynamic sweep and freedom from distortion.

Only the most expensive professional equipment rivals the tape handling ability of the Concertone recorder — and none equals its versatility and simplicity of operation. Especially designed for the most discriminating user, the basic recorder comprises a 14" x 22" rigidly ribbed, cast, aluminum plate carrying the tape mechanism, dual track heads, a shock mounted chassis containing erase amplifier, record amplifier, and playback preamplifier, a power supply chassis, mounting lugs for auxiliary equipment, and all necessary switches and controls, ready for use. Weight: 30 lbs. Easily connected to your existing high fidelity amplifier system. Monitoring directly from the tape while recording gives a constant check and control on what is being recorded while it is being recorded. A much prized program is never lost unknowingly, any departure from proper operation is immediately heard. High speed rewind in either forward or reverse direction, firm, positive braking and fully interlocked controls assure rapid handling without damaging tape. A special circuit controlling a cathode "eye" gives accurate indication of the proper record level for best results. A special locking button prevents accidental erase of recordings.

The Concertone magnetic tape recorder uses any standard reel from the tiny five inch to the professional NAB 10½ inch reel, together with instantaneous choice of 7½" or 15" per second tape speeds, permitting matching frequency response and length of program to operating cost.

- Broadcast studio quality complies with NAB standards.
- Separate heads for high frequency erase, record and playback.
- Simultaneous monitoring from the tape while recording.
- Preamplified heads quickly interchanged for single or dual track.
- Instantaneous choice of 7.5 or 15 inch per second tape speeds.
- Plays standard 5 inch, 7 inch and NAB 10½ inch reels.

- High speed rewind, forward and reverse — 2500 feet in 60 seconds.
- Single or dual track optional.
- Size: 22" x 14" x 5" mounting depth below panel.
- Frequency response: ± 2 db from 50 to 12,500 cycles at 15"/sec.
± 2 db from 50 to 7,000 cycles at 7.5"/sec.
- Total harmonic distortion: Less than 2% at normal maximum signal level.
- Playing time: Up to 2 hours on dual track.

CONCERTONE TAPE RECORDER ACCESSORIES

REEL ADAPTERS

No. 801 — Accurately machined to hold NAB 10½ reels on standard RMA spindles of recorder **3.00**

NAB 10½" REELS

No. 802 — Low inertia 2500 foot reels, flanged on both sides. Conform to NAB recommended standards **2.50**

CARRYING CASE NO. 501

This handsome fitted custom case quickly and easily converts the basic recorder #401 into a complete system for portable use. Supplied with built-in monitoring amplifier #603, and eight inch high fidelity speaker mounted in detachable cover. Convenient to carry; 24" x 15" x 12". Weight: 15 lbs. CONSOLE TRAY AS ILLUSTRATED **14.95**



82⁵⁰

TERMINAL VALUES ON QUALITY PLASTIC RECORDING TAPE

DOMESTIC		PROFESSIONAL	
600 FT.	\$1.35	600 FT.	\$1.65
1200 FT.	2.10	1200 FT.	2.70
2400 FT.	4.20	2400 FT.	5.40

Terminal Radio Corp.
Distributors of Radio and Electronic Equipment

85 CORTLANDT STREET • NEW YORK 7, NEW YORK
WOrth 4-3311



for flawless reproduction
**NO OTHER CARTRIDGE CAN
 PERFORM LIKE A PICKERING**

patented design
DYNAMIC COUPLING*
 provides
throughout the entire audible range

*** DYNAMIC COUPLING ASSURES**

- constant stylus contact with the record grooves over the entire audio spectrum (20-20,000 cps)
- full frequency response
- full transient response

**NO RESONANCES
 NO MISTRACKING
 NO GRINDING OF GROOVE WALLS**

Pickering Cartridges transmit all of the sounds in the musical spectrum, without loss of definition, just as a fine optical lens passes all of the colors in the rainbow.

For literature address Dept. A

Well-informed engineers and technicians, schooled in the science of electro-mechanics, know that only wide-range frequency response provides full transient response; the electronic phenomena which enables the reproduction of orchestral music with all the subtle sounds that give each musical instrument its individual character.

Pickering engineers and designers have but one objective . . . to produce products that will please the music lovers' insatiable appetite for the flawless recreation of recorded music . . . for the utmost in quality insist upon Pickering Audio Components.



Order Your 1951 Bound Volume

SUPPLY LIMITED
\$8.95

AUDIO ENGINEERING

342 Madison Ave.

New York 17, N. Y.

NEW.... by Cabinart
KITS
FOR CORNER FOLDED HORN ENCLOSURES

- The Kit includes:
- LUMBER CUT TO SIZE
 - BAFFLE PRE-CUT FOR 12" OR 15" SPEAKER
 - GRILL CLOTH
 - HARDWARE
 - PLASTIC WOOD
 - GLUE
 - RIMSUL ACOUSTIC INSULATION
 - ASSEMBLY INSTRUCTIONS
 - FINISHING INSTRUCTIONS

Assemble your own folded horn from a Cabinart Kit. All material included. Gain a full octave of clean bass that is never reproduced by ordinary cabinets.

MODEL 61
 12" Speaker
\$19.95

MODEL 63
 15" Speaker
\$23.95

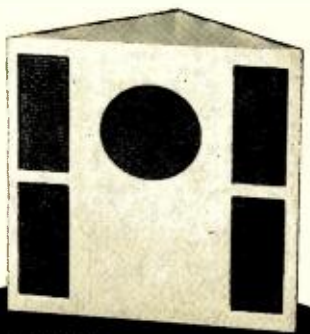

SOLD ONLY THROUGH
 RADIO PARTS DISTRIBUTORS

Your radio parts distributor can obtain this kit from:

G & H WOOD PRODUCTS COMPANY
 75 NORTH 11th STREET • BROOKLYN 11, N. Y. • Evergreen 8-2058

but for my collection I'd rather see one of the Schnabel versions reissued on LP. Schnabel is dead.

Beethoven, Piano Sonata #14 ("Moonlight"). #26 ("Les Adieux").
 R. Serkin. **Columbia ML 4432**

A hard, driving, effective playing of loud, fast parts, rather uneven in the slower; recording is hard, but clean. Breath-sounds audible. This is still not tops for naturalness.

Beethoven, Violin Sonata #10 in G, Op. 96; Violin Favorites.
 Tossy Spivakovsky; R. Firkusky, A. Balsam. **Columbia ML 4402**

A lush and juicy playing of this rather lush Beethoven, nicely miked hi-fi, with better piano than above, the fiddle a bit close. "Favorites" with Balsam) are corny, the violin very close and sharp.

Beethoven, Quartet #15, Op. 132.
 Paganini Quartet. **RCA Victor LM 1179**

This, one of the greatest (and now most popular) of late Beethovens, is not as breathlessly perfect as in a Budapest version, but, with lesser profundity, still has plenty to offer. Good close-to recording in big space, just a hint of slow-period echo in background; nice effect.

More big-orchestra stuff

(As in earlier listings, combining hi-fi on technical side with good miking for the music and good performance, except as indicated)

Dvorak, Violin Concerto in A mi. Milstein;
 Minneapolis Symph., Dorati. **RCA Victor LM 1147**

Dvorak, Cello Concerto in B mi. Casals;
 Czech Philharmonic, Szell. **RCA Victor LCT 1026**

Tchaikowsky, Suites #1, #2 for Orch.
 Winterthur Symphony, Goehr **Concert Hall CHS 1121, 1122**

Sadler's Wells—"Sylvia," Inv. to the Dance, Dance of the Hours.
 Royal Opera House Orch., Rignold **Decca DL 9549**

Rachmaninoff, Symphony #2.
 Phila. Orchestra, Ormandy **Columbia ML 4433**

Tchaikowsky, Symphony #4.
 Vienna State Opera Orch., Scherchen **Westminster WL 5096**

Sibelius, Symphony #2.
 Boston Symphony, Koussevitsky.

Strauss, Don Juan; Wagner, Siegfried's Rhine Journey.
 NBC Symphony, Toscanini. **RCA Victor LM 1157**

Tchaikowsky Waltzes.
 RCA Victor Orch., Reiner **RCA Victor LM 103**

Chausson, Symphony
 San Francisco Symphony, Monteux. **RCA Victor LM 1181**

Rachmaninoff, Rhapsody on a Theme of Paganini.
 Wm. Kapell; Robin Hood Dell Orch., Reiner. **RCA Victor LM 126**

Debussy, La Mer.^{oh} Mendelssohn, Midsummer Night's Dream Music.
 NBC Symphony, Toscanini **RCA Victor LM 1221**

Saint-Saens, Cello Concerto #1.
 Piatigorsky; RCA Victor Symphony, Reiner. **RCA Victor LM 1187**

Pineapple Poll (Gilbert and Sullivan ballet music).
 Sadler's Wells Theatre Orch., Mackerras. **Columbia ML 4439**

Key

* Outstanding over-all sound, ^b Big brass.

° Crashing cymbals, etc. ^d Some distortion in highs. ^b Highs missing. ^o From older 78 issues. ^v Violin solo very close. ^z These best with some bass boost; highs tend to be shrill. ^f Flattish high end; needs boost over normal LP playback.

MUSIC'S THE THING

[from page 21]

system. The closet is approximately 8 ft. high, and it measures 2 ft. 9 in. deep by 6 ft. wide. The general design of the shelving is diagrammed in Fig. 4. The components used in the system are:

Radio Craftmen RC-10 AM-FM tuner
"Musician's" Amplifier and power supply
Rek-O-Kut LP-743 turntable
Pickering Model 190 Arm
Pickering Model 132E Compensator
Two Pickering Diamond Cartridges
Altec 400B speaker in Small baffle

The latter is for the purpose of monitoring the adjustment of controls or for tuning in radio programs. In addition, a simple preamplifier was constructed

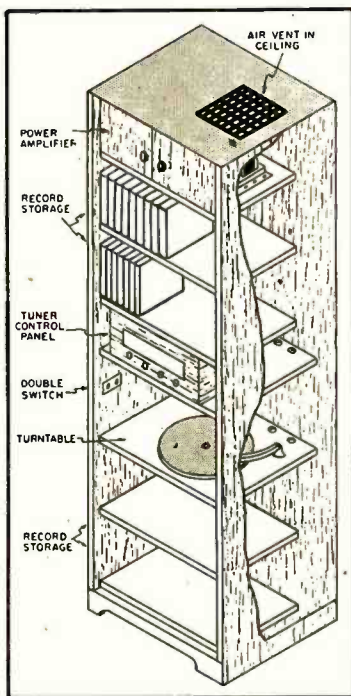

Fig. 4. The closet arrangement provides for mounting tuner, amplifier, power supply, and phonograph turntable with adequate ventilation aided by the overhead vent shown.

in accordance with the schematic of Fig. 5. to provide sufficient gain and low-frequency boost. This unit is of conventional design, and employs a cathode follower output. In conjunction with the Compensator, it provides proper equalization for all types of records. A light mounted above the rear of the record playing system provides adequate illumina-



LEADING ENGINEERS and MFRS. SPECIFY

PAR-METAL

Standardized HOUSINGS
for ELECTRONIC EQUIPMENT

because they're
MADE BY SPECIALISTS,
READY-TO-USE,
LOW IN COST!

CABINETS
CHASSIS
PANELS
RACKS

We manufacture Metal Housings for every purpose — from a small receiver to a deluxe broadcast transmitter. And the cost is low!

Because we specialize in the Electronics field, Par-Metal Products excel in functional streamlined design, rugged construction, beautiful finish, and economy.

Remember, Par-Metal equipment is made by electronic specialists, not just a sheet metal shop.

Made by
Electronic
Specialists!



PAR-METAL

PRODUCTS CORPORATION

32-62 — 49th ST., LONG ISLAND CITY 3, N. Y.

Export Dept.: Rocke International Corp.

13 East 40 Street, New York 16, N. Y.

WRITE FOR CATALOG!



IT'S **ALLIED** FOR **RCA** 
Electron Tubes for Industry

ALL TYPES IN STOCK

- Vacuum Power
- Thyratrons
- Vacuum & Gas. Rect.
- Ignitrons
- Cold-Cathode
- Phototubes
- Oscillograph Tubes
- Camera Tubes
- Monoscopes
- Special Types

FREE Interchangeability Directory

Valuable guide to selection of proper RCA tube type replacements. Lists 1600 tube types. Write for FREE RCA Guide No. 37-046.

Quick, Expert Service on RCA Tubes

ALLIED maintains in stock for quick shipment, the world's largest distributor inventory of RCA special-purpose tubes—of all types. We specialize in supplying the needs of industrial, broadcast, governmental and other users. To save time, effort and money—phone, wire or write to ALLIED. Fill all your needs quickly from the complete, dependable electronic supply source.

See Your 1952 ALLIED Catalog

Refer to your ALLIED Catalog for all electronic supplies—parts, tubes, test instruments, tools, audio amplifiers, accessories available from the world's largest stocks. Write today for your FREE copy of the complete 212-page ALLIED Catalog.

FREE! Send for it now

ALLIED RADIO

833 W. Jackson Blvd., Dept. 17-A-2, Chicago 7, Ill.



Everything in Electronics from ONE Source

PROFESSIONAL DIRECTORY

Custom-Built Equipment

U. S. Recording Co.

1121 Vermont Ave., Washington 5, D. C.
Lincoln 3-2705

Now Ready!

1952
LAFAYETTE CATALOG FREE

Your complete buying guide for everything in electronics.

Authorized distributors for:

Magnecorder	Jensen
McIntosh	Leak
Jim Lansing	Masco
Partridge	Meissner
Altec-Lansing	Pickering
Audax	Presto
Bell	Radio Craftsmen
Bogen	Rek-O-Kut
Brook	H. H. Scott
Browning	Stephens
Electro-Voice	Thordarson
Espey	University
Garrard	Webster-Chicago
G. E.	Wharfedale

This is only a partial listing. Write for our **FREE** High-Fidelity Guide in which you'll find a complete section on custom-built cabinets and ideas on wall installations. (All custom installation work is done in our own workshops at the branch nearest you.)

Our 31st Year
Pioneers in the development of High-Fidelity.

Lafayette Radio

DIV. RADIO WIRE TELEVISION, INC.
NEW YORK: 100 Sixth Ave. REctor 2-8600
BOSTON: 110 Federal St. Hubbard 2-7850
NEWARK: 24 Central Ave. Market 2-1661

Lafayette, Dept. AA
100 Sixth Ave., New York 13, N. Y.

Send me the **FREE** 1952 catalog.

Name _____

Address _____

City _____ Zone _____ State _____

Indicate here if you are interested in our complete High Fidelity Guide, also

nation for changing records or adjusting the Compensator.

For protection against dust and to facilitate mounting the tuner escutcheon, a panel was made to fit against the two shelves above and below the tuner.

A Yagi FM antenna was mounted on the inside of one of the twin chimneys, visible only from an unused part of the

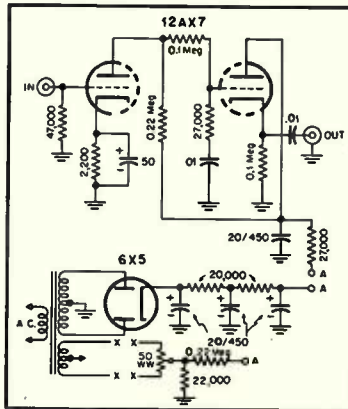

Fig. 5. Simple preamplifier equalized for 500-cps turnover, for use with Pickering Compensator.

grounds. A 300-ohm twin-lead line was brought into the attic below the structure housing the speaker and run to a multiple set coupler, with outputs running to the closet containing the equipment and to Miss Cornell's sitting room in another part of the house, where a second system is contemplated for the future. While the latter is intended to be used primarily for record playing, it will be sufficiently flexible to permit the addition of a radio tuner and connecting the already available antenna lead.

In her new home on a cliff on the Palisades along the Hudson River, our first lady of Shakespearean drama can reap from radio or records the realism and quality she so sincerely puts into her performances for her public . . . us. For now Miss Katherine Cornell, with a high-fidelity music system, is another in the ranks of the audio enthusiasts.

AES Lecture Course

Third course of lectures presented by the Audio Engineering Society will begin in New York January 10. Consisting of six two-hour evening discussions, given on consecutive weeks, the course is aimed at (1) the audio technician in broadcasting and recording, (2) the serious and experienced hobbyist, and (3) the more experienced engineer who wants a refresher course in amplifier design and operating technique.

Lectures will be delivered by recognized authorities in their respective fields, and will be presented in the New York studios of the Gotham Recording Company. Cost for the complete course will be eight dollars to members and twelve dollars to non-members. Complete program may be obtained by writing C. J. LeBel, Secretary, P. O. Box 12, Old Chelsea Station, New York 11, N. Y.

CLASSIFIED

Rates: 10¢ per word per insertion for noncommercial advertisements; 25¢ per word for commercial advertisements. Rates are net, and no discounts will be allowed. Copy must be accompanied by remittance in full, and must reach the New York office by the first of the month preceding the date of issue.

FOR SALE: 600-record collection, mostly classic, in albums and singles little used, \$140. Catalogue on request, Otto Flakowski, 744 Addison St., Chicago, Ill.

USED CONCERTONE or Magnecorder wanted. Harry Dinackus, 4029 Spruce St., Philadelphia, Pa.

KLIPSCH High-frequency horn (K-5) and W.E. 713A Driver, \$125; Stephens 824H horn and P-15 tweeter, \$55; Presto 15G-2 3-speed turntable, \$30; McProud horn with Jensen PLA-15 woofer \$90; Carl Hovland, 151 Hartford Turnpike, Hamden, Conn.

McINTOSH 20W2 basic amplifier, used, perfect condition, \$120. Apt. 3M, 34-35 76th St., Jackson Heights 72, N. Y. Illinois 7-8649.

FOR SALE: New: Livingston Arm with G.E. dual cartridge, \$10.50; G.E. transcription arm FA-21-A, \$25; Rek-O-Kut Master-Pro recording mechanism B-5 with Brush RC-20 cutter, \$100; Rek-O-Kut LP-743 turntable, \$37; Presto PT-900 tape recorder \$820. John Ward, 2500 N. 42, Seattle, Wash.

FOR SALE: Approved Model A-710 tuner with power supply, never used, \$60. John Birch, Box 2641, San Antonio, Texas.

FOR SALE: Western Electric 10A broadcast tuner with external power supply. Make offer. Box CJ-1, AUDIO ENGINEERING.

WANTED TO PURCHASE: Two RCA (ML-11206-B) Type 83-C Isolation Amplifiers, 50 to 10,000 cps. in good operating condition, for non-commercial use. Please send all communications to Box CJ-2, AUDIO ENGINEERING.

FOR SALE: (2) Rek-O-Kut recording turntables, two-speed, 12-in. Model TR12, like new, \$89.50 each; (2) overhead lathes with LP lead screws and heads, like new, \$89.50 each; Elcor tape recorder, two speed, Model 1000, good condition \$75. Immediate Delivery. "Off-the-Air" Records Service, 545 Fifth Ave., New York 17, N. Y.

FOR SALE: Jensen H-510 speaker, used one year. \$70. M. C. Myers, Somerset, Wis.

FOR SALE: Stephens P-15 Driver (brand new) with 8-cellular horn (used). Both for \$50. J. Buld, 720 W. 180th St., New York 33, N. Y.

FOR SALE: Altec Lansing 604B in 605A mahogany cabinet, \$185; Brook 12A basic amplifier, \$50; Meissner 8C tuner, \$25; Webster Chicago 356-27 changer, \$20. Perfect condition guaranteed. Robert Green, Longhill Road, Great Notch, N. J.

SAVINGS up to 40% off net. As new, A-1 equipment. Electro-Voice Patrician 5-way corner speaker, \$550; Klipschorn, Brocner-built, \$375; McIntosh 20W2 plus 2E2A front end, \$175; Fairchild turret arm, with dynamic pickup, output preamplifier, \$90. Elliott, 649 E. 14th St., New York 3, N. Y. O'Regon 7-1669, mornings and evenings.

FOR SALE: Magnavox 101B 30-watt high-fidelity power amplifier (pre-amp. required), \$30; FM tuner, Heath, blond cabinet, like new, \$25; Stromberg-Carlson 1121 AM-FM chassis and matching Stromberg 12-in. speaker, \$50; Vacuum-tube voltmeter, Heath 4A, wired, tested, like new, with leads, \$24. Louis Moench, 2207 Preston St., Salt Lake City 6, Utah.

THE AUDIO EXCHANGE buys and sells high-fidelity sound systems and components. Guaranteed used and new equipment Catalogue. Department AE, 159-10 Hillside Ave., Jamaica 32, New York. OL 8-0445.

FOR SALE: (2) Presto 6N Recording Tables, factory reconditioned, in portable cases; (1) 87B amplifier; various microphones, cables, and accessories. Call between 11 and 12 a.m. or 6 and 8 p.m. Associated Recording Studios, 1625 Broadway, New York 19, N. Y. Circle 5-7351.

NEW LITERATURE

● **Stupakoff Ceramic and Manufacturing Co.**, Latrobe, Pa. is distributing a new 52-page catalog describing the company's entire line of Steatite ceramic products. Included in detailed form are engineering and mechanical data on such items as tubing, coil forms, stand-off insulators, strain insulators, bushings and the like. A complete section of the manual is devoted to general standards for Steatites and other electronic grade ceramics, as adopted by the Steatite Research Council. In writing specify Catalog No. 95.

● **Audio Devices, Inc.**, 444 Madison Ave., New York 22, N. Y. has just issued what may well achieve acceptance as a classic paper in the field of magnetic-tape recording. Titled "Fundamentals of Magnetic Recording," this 50-page pocket-size volume is a complete engineering treatise. It contains valuable data on historical background, recording methods, magnetic relationships, tape characteristics, erasure, frequency response, noise level, distortion, and helpful suggestions on operation and maintenance of equipment. Written by C. J. LeBel, outstanding authority on the science of magnetic recording, the book is exceedingly well-illustrated, and combines in a single volume information heretofore accessible only through widely separated sources. Will be mailed free on request to recordists and audio engineers. This book is certain to excite an unprecedented demand—better write for yours pronto.

● **General Electric Company**, Schenectady 5, N. Y. has issued a new 80-page catalog summarizing for the first time under a single binding all of the company's test and measuring equipment for laboratory and production line applications. Designated Booklet GHC-1016, the manual contains more than 150 pictures and diagrams, and describes the features, specifications and prices of GE test and measuring instruments. Also listed are references to GE bulletins that describe each device in more complete detail.

● **G. K. Leland, Inc.**, Dayton 2, Ohio, describes many production applications of Ledex rotary solenoids, as well as the units themselves, in a new 4-page folder. Illustrated are solenoids with power source requirements ranging from 6 to 650 v.d.c., and in which starting torques for a 45-degree stroke range from one-quarter to 50 pound inches.

● **Standard Transformer Corp.**, 3580 Elston Ave., Chicago 18, Ill. is distributing chart No. 375 which lists 129 of the most frequently used output transformers and the tubes with which they should be matched. This is a handy guide which simplifies the selection of the proper transformer for use as replacement in radio receivers or in the construction of audio amplifiers. Listed are tubes, use, class, watts, load resistance in ohms and the correct Stancor output transformer for each tube type.

● **Concord Radio Corp.**, 901 W. Jackson Blvd., Chicago 8, Ill. will mail free a copy of the company's 48-page catalog of audio equipment titled "Concert Hall Realism with High Fidelity." Along with listings of high-quality audio components, the catalog features a special section for decorators. Illustrated and described are various ways in which music systems can be installed to enhance the motif of any room. Requests should specify Catalog No. HF951.

● **Lenkurt Electric Co.**, County Road, San Carlos, Calif., describes a new carrier system with remarkable thoroughness in folder 32E-P. Capable of superimposing up to four high-quality voice channels and four dial or ringdown-signalling channels on an open wire line, the system operates in the carrier-frequency range from 3.3 to 35 kc. Folder 32E-P covers application, physical description, and operating characteristics.

● **Audio & Video Products Corp.**, 730 Fifth Ave., New York 19, N. Y. describes two new Ampex devices in a 4-page folder which will be mailed on request. The bulk of the bulletin is devoted to the Model 307 tape recorder (See New Products, p. 32), the remaining portion to the Model 375 tuning fork-amplifier. The latter unit provides a highly-corrected source of 60-cycle power for driving the capstan motor of any Ampex recorder, thus assuring correct tape speed irrespective of line-frequency variations.

Something worth thinking about—

ARE DAILY
ADJUSTMENTS
INFLUENCING
YOUR
OPERATING COSTS?

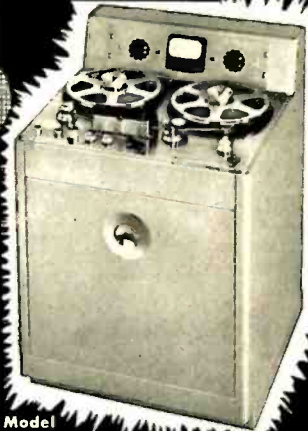

Model
300

There's a big factor showing up in the tape recording world... it's the tragedy of High Maintenance Costs. Many radio stations are confronted with the daily ritual of recorder checking and adjusting. Added to the time cost of such inspections is the cost of frequent parts replacements and loss of program time.

In contrast, Ampex users find their equipment will operate continuously eighteen hours a day with but infrequent inspection. Upkeep and replacements are almost nil; heads have remarkably long life. Ampex performance is constant over long periods of continuous operation. Long life with low maintenance is assured in each Ampex recorder by high manufacturing standards and complete test of each machine before shipment. It all adds up to one sure fact—Ampex quickly pays for itself out of savings from lower operating costs and added dependability.

Complete Specifications on Request

Shown is the time proven Model 300 Console. Throughout the field of professional audio recording this machine is the recognized leader.

STANDARD OF THE GREAT RADIO SHOWS



AMPEX ELECTRIC CORP.
Redwood City, California
Dealers in Principal Cities

AMPEX

Magnetic Tape Recorders

RIGHT!



from
any
angle

A challenging answer to low cost, wide-angle high fidelity reproduction. Diffusicone-12 is a newly engineered speaker with exclusive dual concentric cone design, which diffuses the normally beam-like high frequencies. Results in exceptionally uniform response... assures full range reception over the entire listening area.

Write today for Bulletin 62N73
— address inquiries to Desk 35.

THE NEW

University DIFFUSICONE-12

An Engineering Achievement of UNIVERSITY LOUDSPEAKERS INC.
80 So. Kensico Ave., White Plains, New York

FREE!

NEW 2nd EDITION HIGH FIDELITY GUIDEBOOK

Full of Solid
Information!



Tells All

the things you want to know about High Fidelity! Explains how to bring concert hall realism into the home. Tells what makes a real Hi-Fi Music System. Explains how to select individual components or complete ensembles. Pictures various types of installations — shows how easily you can have your own custom Hi-Fi System at modest cost! Illustrates and describes a complete range of the finest nationally known Hi-Fi units on the market. Prepared for the new enthusiast and for the advanced High Fidelityist. • Send for your FREE Hi-Fi Guidebook today!

GET BIG NEW 1952 CATALOG



OF TV • RADIO • ELECTRONICS
Concord's all-new, complete Buying Guide will save you time and money! Brings you page-after-page of the latest values in world-famous guaranteed parts and equipment for every need! Send today for your FREE copy!

CONCORD RADIO CORPORATION

901 W. JACKSON BLVD. • CHICAGO 7

CONCORD RADIO CORP., Dept. AA-52
901 W. Jackson Blvd., Chicago 7, Ill.

- Rush FREE High Fidelity Guidebook
- Rush FREE Big, New 1952 Catalog

Name _____

Address _____

City _____ Zone _____ State _____

AUDIO IN THE HOME

[from page 19]

er difficulty because of a lack of standardization in measurements. It is our opinion that the R.T.M.A. requirements for high-fidelity have been outmoded, and this can easily be recognized by reading a catalog and then listening to two amplifiers with similar ratings, each of which will sound entirely different. Claims in catalogs about flat response are difficult to compare. One company will say its amplifier is flat within $\frac{3}{4}$ db from 30 to 15,000 cps, and another will claim its amplifier is within 1 db from 20 to 20,000 cps. Both meet R.T.M.A. specifications, but how flat is flat! It has been our experience that most amplifiers would give this flat response only at less than 1 watt power. This might be true of the first amplifier, whereas the other was able to deliver a full 20 watts of power at 20 and 20,000 cps. This is one reason that one amplifier will sound so much better than another.

Another stems from distortion. A certain amplifier has a power output rating of 10 watts at less than 3 per cent distortion, but we find this true only at 400 cps. At 50 and 15,000 cps the same amplifier has distortion above 20 per cent. Another amplifier at 20 watts power has less than 1 per cent distortion at 50, 400, and 15,000 cps. The second is obviously professional, whereas the first is the usual home type. Also affecting the sound are improperly designed tone controls and equalization circuits for magnetic pick-ups, which can make even the best amplifiers sound very poor.

The radio industry in general has

certainly improved in the last few years, as was evident by successive Audio Fairs in New York. Instead of a few amplifiers and speakers, there were many that were of acceptable quality. Nonetheless, there is still the problem of utilizing these components properly together and of housing speakers acoustically correct. In a subsequent article we shall discuss different groups of components and the reasons they go well together.



Employment Register

POSITIONS OPEN and AVAILABLE PERSONNEL may be listed here at no charge to industry or to members of the Society. For insertion in this column, brief announcements should be in the hands of the Secretary, Audio Engineering Society, P. O. Box 12, Old Chelsea Station, N. Y. 11, N. Y., before the fifth of the month preceding the date of issue.

★ Positions Open • Positions Wanted

★ TRANSFORMER and electronic specialty firm in upstate New York anxious to hire engineer experienced in the design of transformers for communication equipment. Salary and opportunities for advancement will be commensurate with the man's ability. Box 101, AUDIO ENGINEERING.

★ LOUDSPEAKER ENGINEER with several years' development and acoustic measurement experience. Large Eastern manufacturer. All replies will be held confidential. Box 102, AUDIO ENGINEERING.

Grand Opening for Audio & Video Products Corp.



On the occasion of the grand opening celebration held on Friday, December 14, at the new offices of Audio & Video Products Corporation, 730 Fifth Avenue, New York, the executives of Ampex Electric Corporation and the Audio-Video organizations got together. From left to right they are: Kenneth B. Boothe, manager of the Instrumentation Division of Audio & Video; T. Kevin

Mallen, Executive Vice President and Chairman of the Board of the Ampex Electric Corporation; Charles E. Rynd, President and Chairman of the Board of the Audio & Video Products Corporation; George Long, Vice President and General Manager of the Ampex Electric Corporation; and Russell O. Hudson, Vice President of the Audio & Video Products Corporation.

The World's Finest Transformer!

Acrosound*

TO-300

(tapped for Ultra Linear Operation)

The principle of Ultra Linear Operation* was discussed in the Nov. 1951 issue of AUDIO ENGINEERING. It provides efficiency, low distortion, and superior listening quality. For example, the popular Williamson circuit arrangement can be readily converted to Ultra Linear Operation, resulting in doubled power output and reducing the distortion by one half.

These improvements are due to this major advancement in output coupling arrangements and to the use of the new Acrosound transformer model TO-300—the world's finest, by any standard!

The ACROSOUND TO-300 features:

- Response ± 1 db—10 cps to 100,000 cps
- Undistorted power—20 cps to 30,000 cps
- Resonance free response
- Unequaled square wave response
- Low phase shift
- Best performance at any price, resulting in unsurpassed listening pleasure

Complete transformer data and parameters available on request along with data on Ultra Linear Operation.

TO-300 \$24.75 net
* Patent Pending

Acro Products Co.

369 Shurs La., Roxborough, Phila. 28, Pa.

If you are moving, you must notify our Circulation Department at least 5 weeks in advance. The Post Office Dept. does not forward magazines sent to wrong destinations unless you pay additional postage, and we can NOT duplicate copies sent to you once. Please give old and new addresses.

RADIO MAGAZINES, INC.

342 Madison Ave.
New York 17, N. Y.

IF YOU BUY ON SPECIFICATIONS



and tops in value, you'll buy the

TWIN-TRAX* TAPE RECORDER
"Choice of Engineers Everywhere"

Compare the guaranteed specifications of a Twin-Trax Tape Recorder with any other recorder in any price class. You'll find that Twin-Trax gives you more features, better all-around performance and more value for your money. Complete specifications, performance ratings and direct factory prices in our catalog 5109. Send for it today.

*Trademark Reg.

AMPLIFIER CORP. of AMERICA

398 Broadway, New York 13, N. Y.

Industry Notes--

Allied Radio Corp., Chicago, has affected top-level reorganization to handle sharply increasing sales and company expansion. A. D. Davis, president announces the following appointments: Alex Brodsky, merchandising manager; S. H. Levey, sales manager; J. W. Rubin, advertising manager; L. M. Dezettel, purchasing agent; W. M. Kordsiemon, general superintendent; A. E. Shapiro, office manager, and C. S. Kanak, credit manager.

Eltron Radio & Electronics Co., Salem, Mass., has promoted George Deters and Fred H. Garcelon to sales managers for Midwestern and Eastern regions respectively.

New sales manager for Stackpole Carbon Co., St. Marys, Pa., is A. K. Neff.

Clarostat Mfg. Co., Inc., Dover, N. H., has engaged Albert W. McCarty, formerly of General Foods Corp., as manager of personnel.

Simpson Electric Co. will soon open new addition to Lac du Flambeau, Wis. branch—will give full employment to the remainder of Chippewa Indians who live on nearby reservation and are now 75 per cent employed by Simpson.

Webster-Chicago Corp. has upped Gus W. Wallin and H. A. Gumz to vice-presidencies.

International Rectifier Corp., Los Angeles, has purchased new factory building in El Segundo, Calif. Present plant will be maintained for research and development. General sales and administrative offices have been transferred to new location.

Sprague Electric Co. has opened new application engineering office in Dayton, O.—will be under management of William M. Lana, former Air Force engineering officer.

Audio-Video Recording Co., Inc., New York, has appointed Dick Stone as sales representative.

Hudson Radio & Television Corp., New York, has added Harold Winberg and Sidney Krinetz to Sound department staff.

Industry People--

Oliver Summerlin, chief engineer of Audio & Video Products Corp., New York, receiving plaudits from industry leaders for magnificent job of planning and installing equipment in A & V's new Fifth Avenue studios.

William H. Finestriber, Jr. who won his spurs in Audio as manager of Carnegie Hall, is new executive v.p. of Mutual Broadcasting System.

Oscar Krant, audio enthusiast of long standing and formerly violinist with the St. Louis Symphony, joins Hudson Radio & Television Corp., New York, to give consulting service to musicians interested in high-quality sound.

Appointment of Anthony K. Lamb to vice-presidency in charge of manufacturing is announced by Earl R. Mellen, president of Weston Electrical Instrument Corp., Newark, N. J. Other recent Weston promotions include George T. Deaney who becomes superintendent of manufacturing, and Raymond T. Pearce who is upped to chief production superintendent.

Entire industry heartened at election of Fred Throver, official of A-V Tape Libraries, Inc., New York, to vice-presidency of CBS Television Network.

Jon Stroup, feature editor of House and Garden, reports December issue a complete sellout thanks, he believes, to 20-page feature article on audio in the home—(Ed's note: Can there be doubt?)

Paul A. Rothschild has joined Oren H. Smith Co., Chicago, as director of sales engineering.

Dick Stuber, formerly executive with Air Associates, has been appointed to head up two-way radio division of Avia Products Co., Los Angeles.

Brig. General David Sarnoff announces election of Robert L. Werner and Ernest B. Gorza as vice-pres. of RCA—will also serve as general attorney and treasurer respectively.

Herman S. Sacks, formerly executive sales administrator for Hudson-Ross, prominent Chicago retailer, has joined Bendix Television and Radio Division of Bendix Aviation Corp. as assistant general sales manager.

Marjorie Meshoum, prominent Chicago commercial artist and audio hobbyist, impressing friends with one of the Windy City's most complete installations of high-quality music equipment—includes such noted names as Hammond, Pickering, Brook, Concertone, etc. With an exhibit like that in his own living room, he's still among those pushing the movement for a Chicago edition of The Audio Fair. How about a few expressions on this subject from A's midwestern constituents? Could be, you know.



NOW... CUSTOM QUALITY enters low price field

AT last a quality variable reluctance, balanced armature magnetic pickup at low cost. The Clarkstan Model 204 features removable and replaceable stylus to permit use with all recordings, LP microgroove, and commercial pressings. Change the size of the sapphire ball point as desired without altering fine performance. Weighs $\frac{1}{2}$ an ounce and plays all popular record changers having standard mounting holes $\frac{3}{8}$ " between centers. Encased in a beautiful transparent case $1\frac{1}{2}$ " overall length. Velocity responsive (flat ± 2 db) from 50 cps to 12,000 cps. Delivers .030 volt from average record.

PRICE: #204 cartridge only with sapphire needle \$5.40 net.
#204-D cartridge only with diamond needle \$21.00 net.

See your jobber or write for Bulletin 7A

CLARKSTAN ELECTRONICS DIVISION 7A
11921 W. PICO BOULEVARD
LOS ANGELES 64, CALIFORNIA



Plays all speeds

GARRARD
"Triumph"
WORLD'S FINEST RECORD CHANGER

Fully automatic with automatic stop
Easily installed in your present set.

Write for FREE literature

GARRARD SALES CORP., Dept. 1E
164 Duane St., New York 13

Gentlemen:
I am interested in learning what to look for when purchasing a 3-speed record changer. Please send me, without obligation, your FACT SHEET.

NAME
ADDRESS
CITY ZONE ... STATE



**A SUGGESTION
THERE IS SOME TRUTH
IN OUR ADVERTISING**

While we were in America, we had the chance to have the performance of the 215 speaker in its Baffle measured by one of the best equipped sound laboratories in the U. S. A. As you will know, we are rather averse to publishing response curves, since they can be so easily misinterpreted, and we wondered just what this opportunity would reveal.

Our own measuring equipment is not truly reliable beyond 15,000 cps, and our previous curves have not shown what happens beyond 10,000. This time we were going to get a story up to 20,000. What would that story be?

We had estimated what the speaker actually did beyond 15,000, which accounts for our claim that it will show up extremely well against any multiple unit system, but could we prove it by measurement? The unqualified answer is "Yes." We are much gratified that independent measurement has confirmed what we thought the speaker really does, and we are even more gratified at an astonishing set of polar curves which show that the 215 has a truly wonderful forward spherical radiation.

These curves are being embodied in a technical report covering the performance of the 215 in detail. A copy will be sent to everyone on our mailing list, and anyone else who is interested—and every high-fidelity enthusiast will be interested to find what can be achieved at so little cost—need only send us a postcard bearing the words "215 report please", and your name and address.

We are often told that our advertisements tend to carry conviction, and that is gratifying to us. Nevertheless, we are glad to be able to prove to you that everything we have said about the 215 speaker is true—by measurement.

**The Hartley-Turner 215 Speaker
is the greatest bargain in the
world of high-fidelity.**

Price only \$48.00. Import duty \$6.00

H. A. HARTLEY CO. LTD.
152, Hammersmith Road
London W.6, England

**ADVERTISING
INDEX**

Acro Products Co.	47
Air-Tone Sound & Recording Co.	2
Allied Radio Corp.	43
Amperite Co., Inc.	8
Amplex Electric Corp.	45
Amplifier Corp. of America	47
Arnold Engineering Co., The	5
Astak Corp.	39
Audak Co.	29
Audio Devices, Inc.	Cover 2
Belden Mfg. Co.	9
Bell Telephone Labs, Inc.	12
Berlant Associates	48
Camera Equipment Co.	40
Chicago Transformer Co.	37
Clarkstan Corp.	47
Classified Ads	44
Concord Radio Corp.	46
Electro-Voice	27
Garrard Sales Corp.	47
Goodman Industries Ltd.	38
G & H Wood Products Co.	42
Hartley, H. A., Co. Ltd.	48
Harvey Radio Co.	34
Heath Co., The	31
Hudson Radio & Television Corp.	7
Jensen Mfg. Co.	25
Lafayette Radio	44
Leonard Radio, Inc.	33
Magnecord, Inc.	30
Maurer, J. A., Inc.	11
Orradio Industries, Inc.	Cover 3
Par-Metal Products Corp.	43
Partridge Transformers Ltd.	48
Permoflux Corp.	4
Pickering & Co., Inc.	42
Presto Recording Corp.	23
Professional Directory	44
Radio Corp. of America	3
Rek-O-Kut Co.	1
Shallcross Mfg. Co.	35
Shure Brothers, Inc.	6
Terminal Radio Corp.	41
Turner Co., The	36
U. S. Recording Co.	44
United Transformer Corp.	Cover 4
University Loudspeakers, Inc.	45

**PARTRIDGE
WILLIAMSON
OUTPUT TRANSFORMER**
*Built to the
original specification*

De-luxe model now available from stock from all important Radio Stores throughout the U.S.A. (Price \$26.00 duty paid)

This transformer is now accepted as the most efficient in the world. According to "Audio Engineering" (Nov. 1949) there is no U.S. equivalent. Thousands already sold in the U.S.A.

Partridge CFB Output Transformer, accepted as without rival. Series leakage induct .10 mh., primary shunt induct, 130 H., with "C" core construction and hermetically sealed. (Price \$40.00 duty paid)

The Following Stores are among those now Stocking Partridge Transformers.

Harvey Radio Co. Inc. 103 West 43rd Street, New York 18.	Terminal Radio Corporation 85, Cortlandt Street, New York 7.
Electronic Wholesalers Inc. 2014 14th Street, N.W., Washington, D. C.	Gates Radio Company, 2700 Polk Avenue, Houston Texas.
Radio Electric Service Co. 5 North Howard Street, Baltimore 1, Maryland.	Wholesale Radio Parts Co. Inc. 311 W. Baltimore St., Baltimore 1, Maryland.
Gates Radio Company, Quincy, Illinois.	Sole Agents in Canada: Atlas Radio Corporation, 560 King Street West, Toronto 2-B.

If you are unable to purchase Partridge transformers in your city, write to us and mention the name of your dealer.

Fullest data, including square-wave tests, distortion curves, etc., together with list of U. S. stockists rushed Air Mail to you.

PARTRIDGE TRANSFORMERS LTD.
TOLWORTH, SURREY, ENGLAND

**Concertone
MAGNETIC TAPE
RECORDERS**

NETWORK
RECORDER
NWR-1

just like being there
**THE ONLY low cost high
fidelity tape recorders
delivering professional
performance. Professional
users' net prices begin at**

\$34500

Write for Bulletin #101
Manufactured By
Berlant Associates
4917 W. Jefferson Boulevard
Los Angeles 16, California

WHAT

OTHERS

SAY

about

SOUND RECORDING



ORRadio

irish
BRAND

MAGNETIC RECORDING TAPE

“**SWEETEST** quality I’ve ever heard”

“Irish Magnetic Tape is the **BEST** I’ve used”

“Orradio Magnetic Tape **RINGS THE BELL** with me”

“I **LIKE** Orradio Irish Tape because it’s so easy to use”

“**CONGRATULATIONS** on your extended frequency performance”

“I use Irish Magnetic Tape because it gives me **EVERYTHING I WANT**
in good quality recordings”

“I am **IMPRESSED** with the fine service of the Orradio organization, as well as the quality of their products. It’s Orradio Tape for me”

From Alaska to South America—from Israel to Korea—words of praise and appreciation for the fine quality of ORRADIO Magnetic Tapes tell the story of what can be accomplished by a small company regardless of overwhelming odds in a competitive market, when users have faith—this is The Spirit that makes America, AMERICA!

To our countless friends all over the world, we say “THANK YOU” for the tremendous part you have played in helping us to produce a commodity that has received such magnificent approval.

Your choice of 2 fine magnetic tapes:

NEW 211RPA Plastic Backing for Professional Users \$5.50 list (1270 feet)

NEW 195RPA Plastic Backing for Slow Speed Recorders \$3.50 list (1270 feet)

THE NEXT TIME YOU need magnetic recording tape — ask for ORRADIO IRISH TAPE at your Electronic Distributor or Photo Supply Shop. Distributors everywhere.

ORRADIO INDUSTRIES, INC. — OPELIKA, ALABAMA



for **MILITARY COMPONENTS**

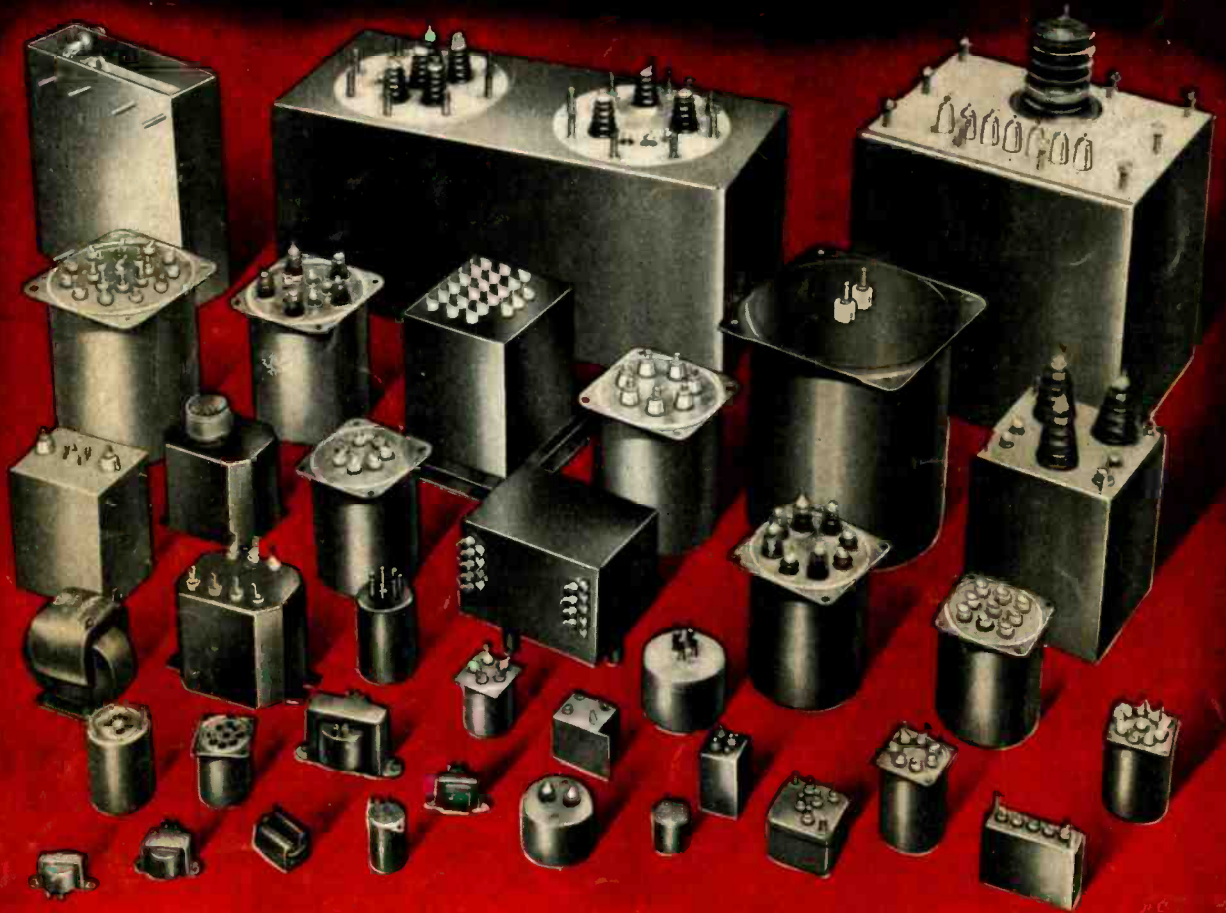

*Precision
Production to
Military
Requirements*

The manufacture of transformers and associated devices for military requirements has been one of the specialties of United Transformer for the past fifteen years. Thousands of military designs are in present production and a few examples are illustrated above.

In this photograph you will find transformers, reactors, filters, high Q coils, and magnetic amplifiers. Types illustrated include units to MIL-T-27, JAN-T-27, and ANE-19.

If you have a tough problem in an Hermetic or Fosterized unit, UTC is your logical production source.

United Transformer Co.
150 VARICK STREET NEW YORK 13, N. Y.

EXPORT DIVISION: 13 EAST 40th STREET, NEW YORK 16, N. Y., CABLES: "ARLAB"

4/1
24/1