

white — blue  
red — green — chrome

# AUDIO

ENGINEERING MUSIC SOUND REPRODUCTION



The Audio Fair—Los Angeles won't have any signs like this at the entrance, but the one in Tokyo did and attracted 55,000 visitors. See Audio Comes to Japan, page 20; for AFLA, page 30.

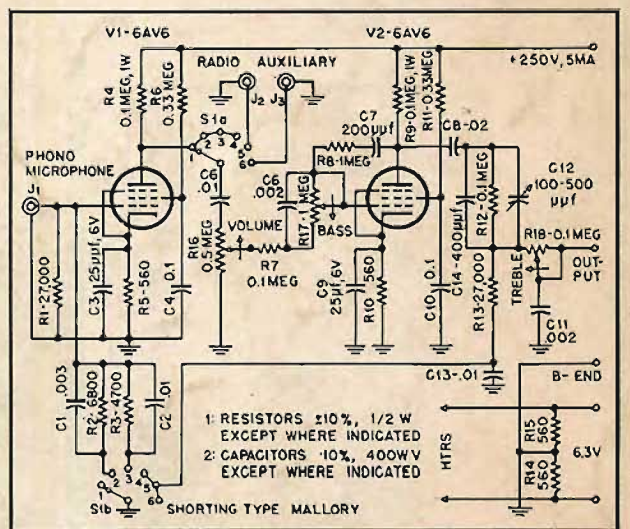

1: RESISTORS  $\pm 10\%$ , 1/2 W  
EXCEPT WHERE INDICATED  
2: CAPACITORS  $\pm 10\%$ , 400V V  
EXCEPT WHERE INDICATED

Preamplifier-tone control units are becoming larger and more elaborate in the commercial field, as in the imagination of many who long for infinite flexibility. But this design is aimed at those who want practical and complete controls without complexity, performance without bulk. See page 20.

SOUND SYSTEM FOR MULTI-USE AUDITORIUM  
 THE MINIATURE PREAMPLIFIER  
 AUDIO COMES TO JAPAN  
 NEW APPROACH TO ELECTRICAL RESONANCE



# AMPEX 600

## for perfectionists only

It's in a class completely by itself. For instance, the Ampex 600 records 30 to 15,000 cycles at 7 1/2 in./sec. Signal-to-noise ratio is over 55 db. Flutter and wow is less than 0.25%. But what matters most is what you hear. There is a monitoring switch on the face of the Ampex 600. Turn it, and you can compare what goes in and what comes out. You will hear no difference. Fidelity is "perfect"—and this is a portable machine that weighs less than 28 pounds.

Though there is a wide selection of tape recorders that can be bought for less, there are great numbers of discerning high fidelity enthusiasts who will hear the difference. And they will want an Ampex 600 and no other.

**The AMPEX 600**—The first truly portable tape recorder capable of meeting the highest professional demands. It is usable either as a portable or in a custom installation—either vertical or horizontal. It plays through an external amplifier and speaker.

**The AMPEX 620**—A portable amplifier-speaker unit of comparable high quality. It is furnished in matched portable case, weighs 19 pounds and provides remarkable high fidelity in a convenient size. Prices: Ampex 600; unmounted \$498; in portable case \$545. Ampex 620 amplifier-speaker in portable case \$149.50



*Here is what Yehudi Menuhin,  
world famous violinist, says:*

"For years I have been seeking a portable recorder to use in practice and rehearsal. In the new Ampex 600, I finally found what I've been looking for—a unit which reproduces music with complete fidelity. Even on tour I practice with Ampex."

*Yehudi Menuhin*

**AMPEX**  
CORPORATION

*The Signature of Perfection in Tape Recorders*

For complete specifications, write today to Dept. B-1886

Distributors in principal cities (see your local telephone directory under "Recording Equipment")

AMPEX CORPORATION • 934 CHARTER ST. • REDWOOD CITY, CALIFORNIA

# AUDIO

ENGINEERING MUSIC SOUND REPRODUCTION

**C. G. McProud, Editor and Publisher**

Henry A. Schober, Business Manager  
 Harrie K. Richardson, Associate Editor  
 Florence Rowland, Production Manager  
 Edgar E. Newman, Circulation Director  
 S. L. Cahn, Advertising Director



**Representatives**

*H. Thorpe Covington and Dick Knott*  
 Special Representatives

7530 North Sheridan Road, Chicago 26, Ill.

*Sanford R. Cowan, Mid-West Representative*  
 67 W. 44th St., New York 36, N. Y.

**West Coast**

*James C. Galloway* *J. W. Harbison*  
 816 W. 5th St., Los Angeles 17, Calif.

**CONTENTS**

Audio Patents— <i>Richard H. Dorf</i> .....	2
New Literature .....	6
Letters .....	8
About Music— <i>Harold Lawrence</i> .....	10
Editor's Report .....	14
Sound System for Multi-Use Auditorium— <i>Thos. R. Hughes</i> .....	17
New Approach to Miniature Preamplifier Design— <i>Arthur J. Rose</i> .....	20
Audio Comes to Japan— <i>Warren Birkenhead</i> .....	22
The Poughkeepsie Audio Society— <i>Charles R. Doty</i> .....	24
Scaling—An Aid in Circuit Analysis— <i>Edgar D. Morgan</i> .....	26
Audio Techniques— <i>R. S. Houston</i> .....	27
A New Approach to Electrical Resonance— <i>N. H. Crowhurst</i> .....	28
Going, Going, Going— <i>Audio Fair—Los Angeles</i> .....	30
Equipment Report— <i>Pilotone AA-420 Amplifier—Sargent Rayment SR-808</i> <i>Tuner-Tone Control—Radio Shack Corporation's Realist Amplifier, FM</i> <i>Tuner, AM Tuner</i> .....	32
Record Revue— <i>Edward Tatnall Canby</i> .....	38
New Products .....	48
Audio ETC— <i>Edward Tatnall Canby</i> .....	50
Glossary of Tape Recording Terms .....	56
Coming Events .....	65
Book Reviews .....	66
Industry Notes .....	75
Advertising Index .....	76

AUDIO (title registered U. S. Pat. Off.) is published monthly by Radio Magazines, Inc., Henry A. Schober, President; C. G. McProud, Secretary, Executive and Editorial Offices, 204 Front St., Mineola, N. Y. Subscription rates—U. S., Possessions, Canada and Mexico, \$4.00 for one year, \$7.00 for two years, all other countries, \$5.00 per year. Single copies 50c. Printed in U. S. A. at Business Press, Inc., 10 McGovern Ave., Lancaster, Pa. All rights reserved. Entire contents copyright 1955 by Radio Magazines, Inc. Entered as Second Class Matter February 9, 1950 at the Post Office, Lancaster, Pa. under the Act of March 3, 1879.

RADIO MAGAZINES, INC., P. O. Box 629, MINEOLA, N. Y.

## Get New FREE PUBLIC ADDRESS HANDBOOK



**Valuable Facts  
 Help You Install  
 Better PA Systems**

*For the first time, such helpful  
 information in a compact Handbook!*

- Shows how to make sound surveys and recommendations—with factory and arena examples.
- Discusses public address requirements in auditoriums, stadiums, large rooms, etc.
- Explains operational factors of importance in public address loudspeaker systems for all types of applications, indoors and outdoors.
- Explains three major points to consider in public address loudspeaker projectors.
- Tells what the CDP Compound Diffraction Projector\* is—what it does—and how it provides a PA speaker system of much greater range, efficiency and dispersion.
- Includes illustrations, diagrams, charts, formulas, engineering data, technical & architectural specifications.

\*Design Patent 169,904  
 Additional Patent Pend.

Send for your FREE copy now  
 or see your E-V Distributor

**Electro-Voice®**

ELECTRO-VOICE, INC. • BUCHANAN, MICH.

Without obligation, send me FREE copy  
 of the CDP Public Address Handbook.

NAME \_\_\_\_\_

ADDRESS \_\_\_\_\_

CITY \_\_\_\_\_ ZONE \_\_\_\_\_ STATE \_\_\_\_\_

# Miniaturization Engineers

**FOR  
RESEARCH,  
DEVELOPMENT  
AND  
APPLICATION  
OF  
SUBMINIATURIZATION  
TECHNIQUES**

Significant advancements in the fields of guided missiles, airborne electronic systems and commercial electronic computers are requiring further applications of miniaturization techniques in the Hughes Advanced Electronics Laboratory. Positions are open for engineers qualified in this work.

### AREAS OF WORK

Techniques involved deal with printed and etched circuits, encapsulation, plastics, metallurgy, dip-soldering, spot-welding, electrochemistry and materials. Development activities are concerned with plug-in units, auto-assembly techniques, potted units, new wiring methods, electromechanical devices, hardware and production techniques. These techniques are used to achieve compactness, reliability, ease of manufacture, serviceability and interchangeability.

### How to apply:

Write today, giving details of qualifications and experience. Assurance is required that relocation of the applicant will not cause disruption of an urgent military project.

Scientific and Engineering Staff

# Hughes

RESEARCH  
AND DEVELOPMENT  
LABORATORIES

Culver City,  
Los Angeles County,  
California

# AUDIO PATENTS

RICHARD H. DORF\*

**H**ERE IS A VOLUME COMPRESSOR or limiter (depending on the effective gain of the control tube) which we present because of its simplicity rather than any startling new concepts. The inventors, Kenneth H. Doriot and George F. McGlumphy of Penn Township, Pa., state that it combines the instant action of a clipper without a clipper's distortion and the constant regulating action of an a.g.c. system. The Patent Office, however, allowed only one claim covering the a.g.c. part. The clipping action, which takes place in the second stage quite independently of the a.g.c. does contribute some distortion and might well be left out by those using this circuit for good-quality recording. The number of the patent is 2,695,338.

The circuit appears in Fig. 1. Ignoring  $R_1$  and  $V_1$  with its associated components, except to note that a d.c. grid-leak path to ground is provided through  $R_1$ , the back-resistance of RECT, and  $R_3$ ,  $V_1$  and  $V_2$  make a standard-looking two-stage amplifier, in which  $V_1$  is a variable- $\mu$  pentode. Bias for  $V_1$  is obtained at the cathode from a voltage divider  $R_3$ - $R_4$  across the B-supply, with  $C_1$  for bypassing. This keeps cathode bias voltage constant and makes the net bias, and thus gain of the stage, dependent on a negative d.c. applied, as discussed below, to the grid. For the same reason screen voltage is obtained from a divider  $R_5$ - $R_6$  across the B-supply, with  $C_2$  as bypass.

The input signal goes not only to the grid of  $V_1$  through d.c. blocking capacitor  $C_3$ , but also to the grid of  $V_2$ , the control tube, through blocking capacitor  $C_4$ , with  $R_7$  as the  $V_2$  grid leak. When a signal appears at the input, it is amplified by  $V_1$ , whose plate is connected through blocking capacitor  $C_5$  to its own internal diode and the audio is thus rectified, appearing across  $R_8$  as a pulsating negative voltage with

respect to ground. This negative voltage passes through RECT, a copper oxide or other kind of dry rectifier, in the forward direction and charges up  $C_6$  negatively with respect to ground. The negative charge on  $C_6$  is applied, of course, to the grid of  $V_1$ , and reduces its gain by an amount proportional to the charge and thus to the amplitude of the incoming signal. This comprises gain-limiting action.

The value of  $C_6$  in relation to that of the forward resistance of RECT comprises a time constant which is quite short, but must be equal to at least one cycle of the lowest frequency to be passed through the system so that the amplifier gain does not follow the audio waveshapes. This is standard in situations of this kind. At all frequencies above the lowest, therefore, one or more cycles of audio will pass through before the amplifier gain is reduced, which is also standard for a.g.c. circuits for obvious reasons.

The circuit should not recover instantly after a high-amplitude signal because, especially with speech, the next word or syllable might also be of high amplitude and this rapid and continual change in gain would be unpleasant. This is taken care of here by the fact that the back-resistance of the rectifier is enormously larger than the forward resistance. Therefore, while  $C_6$  charges quickly, with  $C_7$  chosen for minimum usable charging time, it discharges through the RECT back resistance smoothly and slowly. Thus the next syllable or word will normally come while the gain is still reduced and the desired effect is obtained.

This a.g.c. action is perhaps somewhat better than most in that response to an overloading peak can be theoretically as fast as, say, 1/16 of a second, assuming the low-frequency audio limit to be 16 cps, while the recovery time is very much slower and smooth enough not to cause system noise to give the game away by fluctuating in level obviously.

\* Audio Consultant, 255 W. 84th St., New York 24, N. Y.

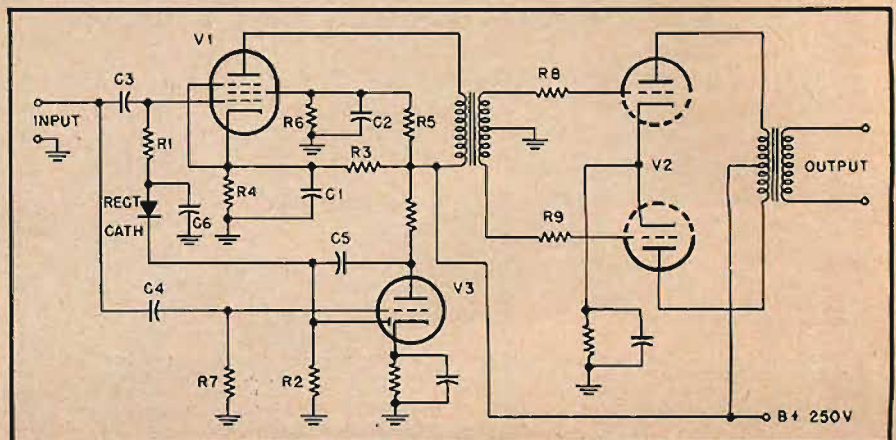

Fig. 1

# Incomparable...

Since 1935  
the Garrard has been  
sold and serviced  
throughout the United States.

It is recognized every where  
for superior  
performance, ruggedness  
and reliability.

**CHECK CRAFTSMANSHIP, FEATURES,  
PRICE AND SERVICE . . .**

and you will understand clearly why this is  
the world's No. 1 high-fidelity record changer.

**"RIGHTS" and "WRONGS"**  
of record changer design  
(important in protecting your records).

**RIGHT:**

Garrard Precision Pusher Platform . . .  
the only record changing device that insures  
positive, gentle handling of records with standard  
center holes.



**WRONG:**

"Overhead Bridges" (as on ordinary changers)  
. . . which may damage or dislodge records  
accidentally.

**RIGHT:**

Garrard removable and interchangeable  
spindles . . . Easily inserted; accommodate all  
records, all sizes, as they were made to be  
played; pull out instantly to facilitate removal of  
records from turntable.



**WRONG:**

Fixed Spindles (as on ordinary changers) . . .  
which require ripping records upwards over  
metallic spindle projections after playing.

Other Garrard features include: 4 pole motor  
—no rumble, no induced hum • heavy drive shaft  
—no wows, no waves • weighted turntable—  
flywheel action, constant speed • muting switch  
—silence between records • silent automatic  
stop—shuts off after last record; no disturbing  
"pop" • easy stylus weight adjustment—pro-  
tects long-playing records • balanced-mounted  
tone arm—true tangent tracking • universal shell  
—fits all popular high fidelity cartridges



## GARRARD "Triumph"



# World's Finest Record Changer

You are cordially invited to visit the British Industries Corporation exhibit at the 3rd Annual Los Angeles Audio Fair, at the Alexandria Hotel, Rooms 315 and 318, February 11 through 13. See and hear Britain's finest audio equipment, including:

**WHARFEDALE LOUDSPEAKERS** . . . designed and built under the personal supervision of G. A. Briggs . . . world renowned authority on sound. Wharfedale Loudspeakers offer the unique construction feature of cloth suspension—a felt buffer between speaker frame and cone—and cast chassis.

**LEAK TL/TO** —High fidelity AMPLIFIER complete with "Point One" REMOTE CONTROL PRE-AMPLIFIER. Most economical amplifier combination ever built by Leak. Harmonic distortion only one tenth of one percent. Insures flawless reproduction. **EXCLUSIVE FEATURE!** Convenient tape recorder jacks (input and output) on front panel for instantaneous use!

**R-J LOUDSPEAKER ENCLOSURES**—"Maximum Bass—Minimum Space" Hearing is believing! R-J Speaker Enclosures have established an entirely new trend in audio design with thrilling performance from any loudspeaker. Bookshelf and Floor Models.

**THE R-J WHARFEDALE** . . . First and only complete R-J unit! Two great products—the R-J single shelf ENCLOSURE and a special WHARFEDALE SPEAKER have been brilliantly matched in this . . . the definitive combination among compact high-performance speakers.

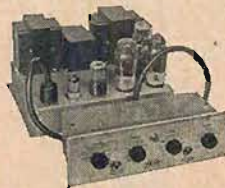

**WRITE FOR A COPY OF  
"SOUND CRAFTSMANSHIP"**

Mail coupon today for a complimentary copy of "Sound Craftsmanship" 16 pages illustrating and describing all products of the British Industries Group.

**BRITISH INDUSTRIES CORP., Dept. A-2**  
164 Duane Street  
New York 13, N. Y.

Please send "Sound Craftsmanship" to:

Name \_\_\_\_\_

Address \_\_\_\_\_

City \_\_\_\_\_ Zone \_\_\_\_\_ State \_\_\_\_\_



## WHY A PROFESSIONAL STUDIO MICROPHONE FOR HOME RECORDING?

### SHURE CONCERT-LINE "333"

Tested and approved by  
DOWN BEAT'S Hi-Fi Buyers Aid (Oct. 20, 1954)



CONCERT-LINE "333"



For treasured recordings in your home you always can depend on this Shure Concert-Line Studio Microphone. It is highly recommended for the most discriminating users who insist on the finest equipment—because they know that for professional results a professional microphone must be used.

The Concert-Line "333" is a slender, rugged, truly high-fidelity microphone. It is uni-directional, reduces random noise pickup by 73%. This means that the distracting background noises you so frequently encounter when using conventional microphones for home recording are almost completely eliminated.

The "333" has a smooth, extended frequency response of 30-15,000 c.p.s., plus or minus 2½ db—perfect for vocal or instrumental, solo or group recordings. It is equipped with a voice-music switch for added flexibility in achieving the finest recordings.

Write for the informative Catalog 33, which gives complete descriptive literature on the Model "333"—or see your Shure Distributor.

**SHURE**

*The Mark of Quality*

Sales Division, Shure Brothers, Inc., 225 W. Huron Street, Chicago 10, Ill.

Anyone who builds the device may want to be able to control the degree of a.g.c. and this is simply done by converting  $R_7$  to a potentiometer with the  $V_2$  grid connected to the pot arm. As to time constants, the value of  $C_1$  should govern attack almost entirely since the forward resistance of a rectifier is negligible. Decay of the a.g.c. voltage could be hastened by placing a suitable resistor across  $C_2$  or perhaps across the rectifier.  $R_1$  must, of course, be kept high since it isolates  $C_2$  from the  $V_1$  grid and prevents it from acting as a low-pass filter.  $C_1$  can be removed, incidentally, if the input signal contains no d.c. And except for the following clipper stage,  $V_1$  can have a resistance-coupled output circuit.

$V_2$ , which need be used only where even a very short overmodulation peak might destroy equipment or relations with the FCC, is a clipper stage which operates as such only during the short period required for  $C_2$  to charge up and reduce the gain of  $V_1$ . The clipping creates distortion, of course, but it happens for such brief periods that the inventors claim its effect is negligible.

The  $V_2$  stage looks like an ordinary push-pull arrangement, except for  $R_3$  and  $R_4$ , but is biased so that it operates near the knee of its saturation curve. This means that the increase of plate current in each triode is not proportional to the increase in positive grid voltage. In addition, the stage will absolutely clip off the tops of any wave whose peak amplitude is more than 10 per cent greater than the average amplitude and additional positive grid voltage above a certain point will produce no increase in plate current, presumably due to a negative voltage drop across  $R_3$  or  $R_4$  caused by grid current. All this, we assume, takes place near maximum desired amplitude, the stage operating linearly at normal levels.

The usual user will employ only the  $V_1$  and  $V_2$  portions of the system, using resistive output for  $V_1$  and feeding signal from here to whatever the next voltage-amplifier stage would normally be. We would like to give you values of  $R$  and  $C$  and exact tube types for the circuit, but the inventors didn't give them and we haven't done the necessary design work. They should not be hard to arrive at, however, with a little intelligent experimentation.

You may have a copy of this or any other U. S. patent for 25 cents from The Commissioner of Patents, Washington 25, D.C.



GO WEST

AUDIO FAIR—L. A.

February

10-11-12-13

Alexandria Hotel

# THE TAPE YOU'VE BEEN WAITING FOR!

SOUNDCRAFT  
**"PLUS 50"**  
 (50% EXTRA PLAYING TIME)  
 magnetic recording tape



- 50% EXTRA PLAYING TIME
- EXTRA STRENGTH "MYLAR" BASE
- FULL DEPTH OXIDE COATING
- ... YET COSTS NO MORE

**PLUS 50**

is the *perfected* "long-playing" magnetic tape, bringing you *50% extra* playing time with no compromise in strength or recording quality.

One reel of "Plus-50" is equal in recording or playback time to 1½ reels of standard tape. More listening per reel . . . less time changing reels. Best of all, Soundcraft "Plus-50" *actually costs less per foot* than quality acetate-base tapes!

The secret of "Plus-50" lies in its extra thin "Mylar" base (1 mil as compared to 1.5 mils in acetate tapes). "Mylar," DuPont's Polyester Film, con-

tains no plasticizer. It will not cup or curl. Elongation and shrinkage from heat, cold and humidity are barely measurable. And it's far stronger than the thicker acetate . . . one third as strong as steel!

There has been no compromise in the development of "Plus-50"—a big advantage for you! The oxide coating is *constant, full-depth*—to maintain correct frequency response, output level, and bias characteristics. No machine adjustments are needed. "Plus-50" can be interspliced with other fine quality tapes without level change.

See your Soundcraft Dealer for "Plus-50" as well as these other famous Soundcraft Magnetic Recording Tapes:

**Soundcraft Recording Tape** (in the box with The Red Diamond) the all-purpose "Standard of the Industry."

**Soundcraft Professional Tape** (in the box with The Blue Diamond) for radio, TV and recording studios. Splice-free up to 2400 feet. Standard or professional hubs.

**Soundcraft LIFETIME® Tape** (in the box with The Yellow Diamond) for priceless recordings. DuPont "Mylar" base. For rigorous use . . . perfect program timing. Store it anywhere virtually forever.

Soundcraft Tapes are the world's finest—and yet they cost no more.

**FOR EVERY SOUND REASON**

**REEVES SOUNDCRAFT CORP.**  
 10 East 52nd St., New York 22, N. Y.

**MAKE  
YOUR  
OWN**

**HIGH  
FIDELITY  
RECORDS**

with the **REK-O-KUT**

# Challenger

**PORTABLE DISK RECORDER AND  
PLAYBACK PHONOGRAPH**

The outstanding advantages of a disc recording is that it is permanent and it can be played back on any phonograph. Because of this, most tape recordings ultimately end up on discs.

If you would like to add your favorite tape recordings to your regular record library, it is a simple procedure to cut your own high quality record discs with a Rek-O-Kut Challenger. And you can also make direct recordings on disc—"live" or "off-the-air"—at 33½, 45 or 78 rpm. And when the discs are finished, you can play them back immediately on the Challenger or on your own high fidelity music system.

The Challenger is the only portable recorder that employs a professional overhead cutting lathe with interchangeable lead-screws, and a turntable driven by a hysteresis synchronous motor. The playback amplifier has a frequency response from 20 to 20,000 cycles  $\pm$  1 db with independent bass and treble controls. A wide-range 10-inch speaker is mounted in the detachable cover. The playback arm is equipped with a dual sapphire magnetic pickup.



**REK-O-KUT Challenger**  
for 33½ and 78 rpm—with Standard  
Groove Leadscrew . . . . \$459.95  
45 rpm Accessory Idler . . . . 8.00

*For complete description, write Dept. AB-1*

**REK-O-KUT COMPANY**  
MAKERS OF THE FAMOUS *Rondine* TURNTABLES  
38-01 Queens Boulevard, Long Island City 1, N. Y.

## NEW LITERATURE

• **Allied Radio Corporation**, 100 N. Western Ave., Chicago 80, Ill., is offering free of charge an interesting two-color booklet which explains high-fidelity reproduction of voice and music. The attractively-illustrated booklet is titled "This is High Fidelity." It explains in non-technical language the functions of the basic units which are used in home music systems. The booklet also discusses what percentage of the hi-fi dollar should be devoted to each component, and includes tips on how to save money for the budget-minded. A separate section shows ways of modernizing existing equipment.

• **Acro Products Company**, 369 Shurs Lane, Philadelphia, Pa., covers the complete line of Acrosound Ultra-Linear transformers in a new 16-page booklet available on request. Along with a thorough description of each item, the booklet is replete with schematics which show various Acrosound transformers used in many types of amplifier circuits.

• **Centralab Division of Globe-Union, Inc.**, 900 E. Keefe Ave., Milwaukee 1, Wis., has available for service engineers, amateurs and experimenters a thoroughly revised 16-page catalog containing technical data and illustrations of the company's five stock lines of controls and electronic components. Among the items listed are Fastatch dual controls, Snap-Tite controls, and various types of switches and capacitors. Request for free copy of Catalog No. 29 should be addressed to Dept. A-32.

• **Carter Motor Co.**, 2648 N. Maplewood Ave., Chicago 47, Ill., in its latest dynamotor catalog No. 155 presents 28 attractively illustrated pages which provide both electrical and mechanical specifications of all Carter products. Cataloged for the first time is the improved Carter Change-A-Volt dynamotor, by which it is possible to use present 6-volt mobile radio equipment in the new cars with 12-volt electrical systems without rewiring or tube replacement. Requests should be directed to Dept. 10.

• **Altec Lansing Corporation**, 3356 Santa Monica Blvd., Beverly Hills, Calif., is now releasing its new catalog titled "Jobber Sound Products." This catalog gives complete data on eight different Altec microphones including the special scientific condenser microphones for the measurement of high-intensity sounds and the newly-developed heart microphone for cardiovascular research. Amplifiers, speakers, horns, cabinets and 70-volt transformers are also included. Copy may be obtained from the company or from its authorized jobbers and dealers.

• **E-Z Way Templates**, 2242 S. Colby Ave., Los Angeles 64, Calif., has available literature on templates for electronic engineers, draftsmen, and designers. Among items covered are vinyl plastic templates for layout of vacuum-tube sockets, capacitor twist-lock bases, rotary-selector switches, and vacuum-tube outlines. Inquiries should be directed to the attention of Richard D. Blayney.

• **Trio Laboratories, Inc.**, 3293 Seaford Ave., Wantagh, N. Y., will mail to interested parties a series of four Engineering Bulletins which describe the company's line of miniature panel-mounting vacuum-tube voltmeters, auxiliary power supplies, and the technique of obtaining automatic scale selection in test equipment design. The sheet covering the VTVM is of great interest to users of portable equipment, designers of airborne devices, and manufacturers of complex test instruments.

• **Beckman Instruments, Inc.**, 220 Pasadena Ave., South Pasadena, Calif., has issued a 4-page illustrated bulletin describing d.c. and a.c. expanded-scale panel voltmeters which are now available from the company's Arga Division. Tables are given for base voltages, spans, and accuracy. In all of these meters only the range of interest is included on the scale; the remainder of the scale has been discarded for greater expansion and consequent ease of reading.



*"Praise... owes its value only to its scarcity"* — Samuel Johnson

---



## C. G. McPROUD

Editor of  
**Audio Magazine**

"From the standpoint of economy alone, the diamond stylus will give many more hours of high-quality reproduction per dollar than any other. Aside from that, however, the possibility of damage from a worn stylus is reduced considerably, and I will not use any pickup for more than an hour or so unless it has a diamond stylus."



PLAY SAFE  
PLAY DIAMOND

# TETRAD

WORLD'S LARGEST  
MANUFACTURERS  
OF DIAMOND STYLI

Ask your dealer or serviceman for a **BRAND NAME DIAMOND**  
Record-Needle Care Folders: Dept. U-2, 62 St. Mary Street, Yonkers, N. Y.

# BE YOUR OWN AUDIO ENGINEER

MODEL 80  
MODEL 8112  
MODEL 8115

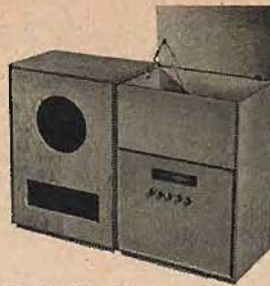

## CABINART

H I F I	EQUIPMENT CABINET
	SPEAKER CABINET

Model 80 has lift lid, removable panels. Bass reflex tuned for 12" or 15" speakers. Overall dimensions: 33 1/2" H, 23" W, 14" D. M80 tuner section. Inside: 20" H, 21 3/4" W, 15 1/2" D. M8112, M8115 baffle volume: 6 cubic feet. 5/8" white pine

80	equipment cabinet kit	\$27.00
8112	12" speaker cabinet kit	18.00
8115	15" speaker cabinet kit	18.00

# K I T S

ACOUSTICALLY ENGINEERED — ASSEMBLED WITH ONLY A SCREWDRIVER!

FEATURING  
THE KLIPSCH-DESIGNED

## Rebel\* 4 KITS

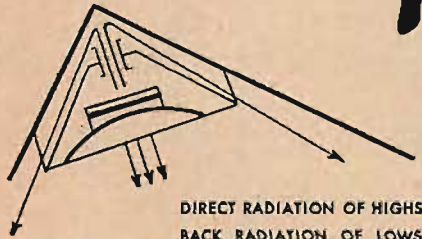

DIRECT RADIATION OF HIGHS  
BACK RADIATION OF LOWS



MODEL K-12  
MODEL K-15  
K. 12 36.00  
K. 15 42.00

ready-to-finish birch

All kits precision-cut to size, baffles pre-cut for 12" or 15" speakers. Kits include Saran plastic acoustic cloth, glue, sandpaper, plastic wood, hardware, assembly instructions and finishing instructions. Write for complete catalogs and nearest Cabinart kit dealer.

REBEL enclosure development entails a cavity and slot port, to form a resonant chamber, and a horn coupled to the slot. The slot is loaded by the horn; the proportioning of slot, cavity and horn provide bass response below 100 cycles which corresponds in efficiency to the front-of-cone direct radiator response above this critical 100-cycle point. There are two ways one might consider the function of this horn. One is a bass reflex with a horn acting as a resistive load on the port. System resonances are damped by useful radiation resistance while the horn does not cost anything. It is already formed by the room corner. Again, if a full horn were added below the 100-cycle point bass response would be boomy and unnatural. But, in the Rebel enclosures, the cavity-port combination acts as an acoustic low pass filter. And its design is such that low-end response will compare with response higher in the sound scale.

Model 61, Model 63  
corner horn



12" speaker — \$19.95  
15" speaker — \$23.95

all prices slightly higher west and south

\* Trade Mark

KITFORMS BY CABINART

75 North 11th Street  
Brooklyn, N. Y.

## LETTERS

### Apology

SIR:

Mr. Neaman, senior attorney for the Columbia Broadcasting System, has called our attention to certain comments appearing in our article published in the August, 1954, issue of *Auro*. The article has evidently been the cause of an unfortunate misunderstanding.

Mr. Neaman's criticisms were especially directed to the use of the word "sorcery," and he has applied to that word a very literal dictionary connotation. It is believed, however, that the word, as it appears in context, does not convey to the reader such a meaning. Actually, the word was used in a colloquial sense to indicate the complexities inherent in listener tests generally. Certainly, it was not intended to be considered as a personal reproach to either Mr. Chinn or Mr. Eisenberg, nor to convey the meanings attributed to it by Mr. Neaman.

We are, as is the profession generally, well aware of the significant contributions and advancements to science which each of them has made and would not, intentionally or otherwise, do anything which might impugn their fine reputations. In view of the respect we have for their ability and competency, we unhesitatingly wish to and do offer our profound apologies for any misunderstandings which may have been caused by the article.

JAMES CUNNINGHAM,  
National Broadcasting Company, Inc.,  
Merchandise Mart,  
Chicago 54, Ill.  
ROBERT OAKES JORDAN  
Robert Oakes Jordan & Associates,  
929 Marion Avenue,  
Highland Park, Ill.

### Future Article Requests

SIR:

I have two suggestions for future articles which strike a note of keen interest for me, and possibly, I believe, for many others of your readers. They are:

1. The question of the effect of crossover networks on the damping factor of amplifiers. To date this has not been explained clearly, although Wentworth (Dec. 1952) stated that even the popular crossover network employing two capacitors and two inductances was very poor from the standpoint of damping. Wentworth recommended taking feedback voltage after, rather than before, the crossover network, although the calculation of feedback was not too well explained.

In view of all the current interest in current feedback, I should like to see an article specifically discussing the best way to apply feedback when speaker crossover networks are used.

2. For the benefit of this particular apartment dweller and the multitude of other of your subscribers who face an adamant anti-9-cubic-foot-enclosure wife, please test and report on the small cabinet and novel speaker design described by Villchur (Oct. 1954). Is this really the answer to big clean bass in small space?

(Continued on page 65)

**GREATER VERSATILITY  
HIGHEST QUALITY  
MAXIMUM CONTROL**

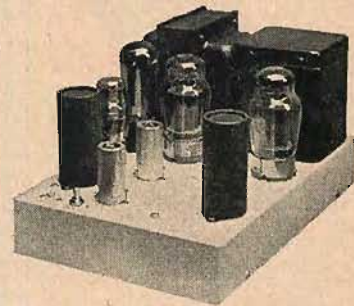
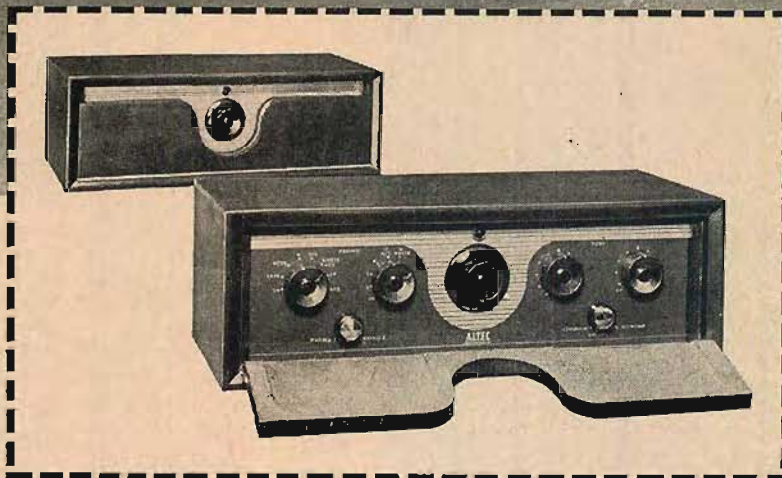

**the new ALTEC A-440A preamplifier  
and the A-340A amplifier!**

Here are Altec's latest developments in high fidelity control and amplification. Now you can have home music system components with the same conservative design and ratings found in the thousands of Altec Lansing control consoles and amplifiers in use in broadcast and recording studios throughout the world. Although specifically designed for home use, these units are truly professional in concept, design, construction and flexibility. They offer more and finer control than any other home units available. A striking feature of design is the door of the A-440A preamplifier. With the door closed, the unit is inconspicuous and only the all important on-off volume control is exposed. With the door open, the unit presents controls to gratify the most particular. If you want the finest you want the new Altec A-440A and A-340A.

**The A-440A:** five inputs with individual level controls • smartly designed hardwood cabinet • 25 record playback characteristics • loudness-volume selection • full range separate bass and treble controls • tape recording output from any input • tape playback monitoring while recording • self-contained power supply • d.c. heater supply • low noise tubes.

**The A-340A:** 35 watts at 0.5% distortion •  $\pm \frac{1}{2}$  db 5 to 100,000 cycles • 66.5 db gain • 200,000 ohm input • adjustable output impedance • power tubes with 100 watt capacity • simple circuitry • exceptional stability (no tube selection or balancing needed) • gain control.

**Altec Fidelity is HIGHEST Fidelity**

See your **ALTEC HIGH FIDELITY**  
**DEALER** now for complete  
details or write Department 2-A



Dept. 2-A  
9356 Santa Monica Blvd., Beverly Hills, Calif.  
161 Sixth Avenue, New York 13, N.Y.

For the Finest in

# MUSICAL QUALITY

## CHROMATIC Hi-Q7

World-famous CHROMATIC performance. Higher output overrides interference. (See Canby, p. 86, Oct.) This magnetic unit plays all speed records. In effect, two cartridges, one diamond and one sapphire. Of course, both replaceable—AT HOME. Net \$41.70



## COMPASS-PIVOTED ARM

Most efficient arm—barring none. NO SPRINGS, no fatigue. New adapter makes Audax Compass-Pivoted arms useable with most cartridges. Adapter is of all metal construction.

#12 arm  
Net \$13.80  
Adapter  
Net \$ 4.80



## STYLUS-BALANCE

75% of cartridges in use operate with incorrect stylus-pressure. This means record destruction. Stroboscope-like, STYLUS-BALANCE indicates correctness or incorrectness of stylus-pressure. Works with any cartridge, any arm. All metal construction. Net \$4.80



Write for literature and FREE copy of ELECTRONIC PHONO FACTS.

## AUDAX COMPANY

500 Fifth Ave. Dept. A New York 36

Audio-Electronic apparatus over 25 years

# ABOUT MUSIC

HAROLD LAWRENCE\*

## The Measure of Wilhelm Furtwängler



The late Wilhelm Furtwängler

WHEN THE SPECIAL BULLETIN broke into WQXR's regular mid-morning concert on Tuesday, November 30th, with the announcement of the death in Baden-Baden, Germany, of Wilhelm Furtwängler, a shiver must have run down the spine of more than one listener. For, by an eerie coincidence, immediately after the "flash" was read, the program continued with its scheduled selection: *Siegfried's Funeral Music* from Wagner's *Die Götterdämmerung*. The growling double bass figure and pungent brass chords seemed an eloquent commentary on this new irreplaceable loss. Among the foremost conductors of his day, Furtwängler, who died at 68, was virtually a youngster, with Toscanini at 87, Walter at 78, Beecham at 75, and Monteux at 79. His premature death (cause: pneumonia) signifies more than the cutting short of the career of a persuasive and superbly trained musician. The cloud of controversy, under which the conductor had been living for more than two decades, was at last about to be dispersed. Sponsored by the Bonn government, Furtwängler was to lead the Berlin Philharmonic Orchestra on an American tour early this year. Six years ago, that would have been an impossibility.

Plans were then afoot to have Furtwängler conduct the Chicago Symphony Orchestra. When subscribers, guest artists

and the press got wind of it, an outcry was raised that he had been a Nazi sympathizer. Rather than prolong the business, Furtwängler turned down the invitation—this, despite the fact that the Allies had cleared him of the Nazi taint the previous year, and in Paris, in January 1948, French audiences had welcomed him with open arms. Ironically, those countries that suffered most from German militarism were the first to recognize the separation of art from politics. In the French capital, for instance, German conductors and soloists ("tainted" or otherwise) are acclaimed.

Protests over the appearance of such artists in the United States have been far from consistent. Picket lines forced the cancellation of Gieseking's first postwar Carnegie Hall recital, but no one kicked up a row when the Metropolitan Opera House hired a singer who likewise had thrived under the Nazi regime, and who, in 1936, was appointed tenor to the Saxon court. Proof of the absurdity of musical boycotts occurred in Haifa, Israel on April 13, 1953 when Jascha Heifetz broke a 20-year ban on the playing of music by German composers and received a thunderous ovation for his performance of the Strauss Violin Sonata. (Later, a fanatic struck the virtuoso a blow on the wrist with a metal object when he played the work again.) But politics and music are really not the concern of this article.

Furtwängler's early career can only be described as meteoric. Within seven years, he attained the dream of every conductor in pre-war Germany: leadership of the Berlin Philharmonic Orchestra. The first step in this direction took place in 1915 when he succeeded outgoing Artur Bodansky as operatic and concert conductor at Mannheim, a post that had been created in 1779. From there he migrated to Vienna, then to Berlin as conductor of the State Opera Orchestra. In 1922, he followed Nikisch as leader of the Gewandhaus concerts, and finally took over the Berlin Philharmonic.

Such a phenomenal rise seems to belie the fact that Furtwängler was essentially naive in his business relations. Timid, sensitive, wrapped up in his own thoughts, he was guided—or rather led—into an even more powerful position by his shrewd general secretary, Berta Geissmar. He was about to accept the Vienna State Opera directorship starting with the 1929 season when Fräulein Geissmar brusquely interrupted a handshake on the agreement between the conductor and the Viennese manager, and hustled Furtwängler back to

\* 26 West Ninth St., New York 11, N.Y.

**GREATER VERSATILITY  
HIGHEST QUALITY  
MAXIMUM CONTROL**

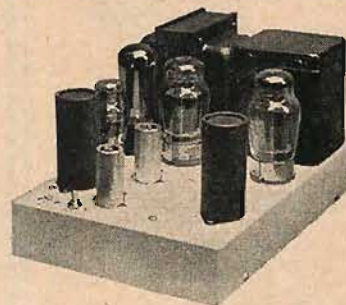
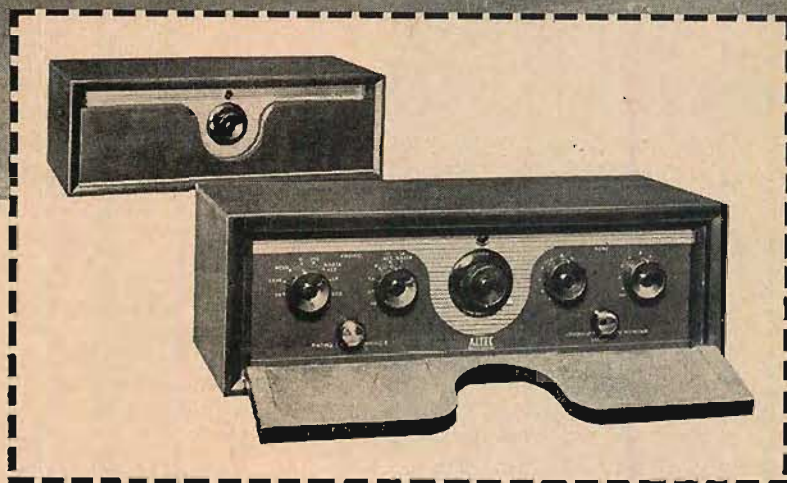

**the new ALTEC A-440A preamplifier  
and the A-340A amplifier!**

Here are Altec's latest developments in high fidelity control and amplification. Now you can have home music system components with the same conservative design and ratings found in the thousands of Altec Lansing control consoles and amplifiers in use in broadcast and recording studios throughout the world. Although specifically designed for home use, these units are truly professional in concept, design, construction and flexibility. They offer more and finer control than any other home units available. A striking feature of design is the door of the A-440A preamplifier. With the door closed, the unit is inconspicuous and only the all important on-off volume control is exposed. With the door open, the unit presents controls to gratify the most particular. If you want the finest you want the new Altec A-440A and A-340A.

**The A-440A:** five inputs with individual level controls • smartly designed hardwood cabinet • 25 record playback characteristics • loudness-volume selection • full range separate bass and treble controls • tape recording output from any input • tape playback monitoring while recording • self-contained power supply • d.c. heater supply • low noise tubes.

**The A-340A:** 35 watts at 0.5% distortion •  $\pm \frac{1}{2}$  db 5 to 100,000 cycles • 66.5 db gain • 200,000 ohm input • adjustable output impedance • power tubes with 100 watt capacity • simple circuitry • exceptional stability (no tube selection or balancing needed) • gain control.

**Altec Fidelity is HIGHEST Fidelity**

See your **ALTEC HIGH FIDELITY**  
**DEALER** now for complete  
details or write Department 2-A



Dept. 2-A  
9356 Santa Monica Blvd., Beverly Hills, Calif.  
161 Sixth Avenue, New York 13, N.Y.

For the Finest in

# MUSICAL QUALITY

## CHROMATIC Hi-Q7

World-famous CHROMATIC performance. Higher output overrides interference. (See Canby, p. 86, Oct.) This magnetic unit plays all speed records. In effect, two cartridges, one diamond and one sapphire. Of course, both replaceable—AT HOME.  
Net \$41.70



## COMPASS-PIVOTED ARM

Most efficient arm—barring none. NO SPRINGS, no fatigue. New adapter makes Audax Compass-Pivoted arms useable with most cartridges. Adapter is of all metal construction.

#12 arm  
Net \$13.80  
Adapter  
Net \$ 4.80



## STYLUS-BALANCE

75% of cartridges in use operate with incorrect stylus-pressure. This means record destruction. Stroboscope-like, STYLUS-BALANCE indicates correctness or incorrectness of stylus-pressure. Works with any cartridge, any arm. All metal construction.  
Net \$4.80



Write for literature and FREE copy of ELECTRONIC PHONO FACTS.

## AUDAX COMPANY

500 Fifth Ave. Dept. A New York 35

Audio-Electronic apparatus over 25 years

# ABOUT MUSIC

HAROLD LAWRENCE\*

## The Measure of Wilhelm Furtwängler



The late Wilhelm Furtwängler

WHEN THE SPECIAL BULLETIN broke into WQXR's regular mid-morning concert on Tuesday, November 30th, with the announcement of the death in Baden-Baden, Germany, of Wilhelm Furtwängler, a shiver must have run down the spine of more than one listener. For, by an eerie coincidence, immediately after the "flash" was read, the program continued with its scheduled selection: *Siegfried's Funeral Music* from Wagner's *Die Götterdämmerung*. The growling double bass figure and pungent brass chords seemed an eloquent commentary on this new irreplaceable loss. Among the foremost conductors of his day, Furtwängler, who died at 68, was virtually a youngster, with Toscanini at 87, Walter at 78, Beecham at 75, and Monteux at 79. His premature death (cause: pneumonia) signifies more than the cutting short of the career of a persuasive and superbly trained musician. The cloud of controversy, under which the conductor had been living for more than two decades, was at last about to be dispersed. Sponsored by the Bonn government, Furtwängler was to lead the Berlin Philharmonic Orchestra on an American tour early this year. Six years ago, that would have been an impossibility.

Plans were then afoot to have Furtwängler conduct the Chicago Symphony Orchestra. When subscribers, guest artists

and the press got wind of it, an outcry was raised that he had been a Nazi sympathizer. Rather than prolong the business, Furtwängler turned down the invitation—this, despite the fact that the Allies had cleared him of the Nazi taint the previous year, and in Paris, in January 1948, French audiences had welcomed him with open arms. Ironically, those countries that suffered most from German militarism were the first to recognize the separation of art from politics. In the French capital, for instance, German conductors and soloists ("tainted" or otherwise) are acclaimed.

Protests over the appearance of such artists in the United States have been far from consistent. Picket lines forced the cancellation of Giesecking's first postwar Carnegie Hall recital, but no one kicked up a row when the Metropolitan Opera House hired a singer who likewise had thrived under the Nazi regime, and who, in 1936, was appointed tenor to the Saxon court. Proof of the absurdity of musical boycotts occurred in Haifa, Israel on April 13, 1953 when Jascha Heifetz broke a 20-year ban on the playing of music by German composers and received a thunderous ovation for his performance of the Strauss Violin Sonata. (Later, a fanatic struck the virtuoso a blow on the wrist with a metal object when he played the work again.) But politics and music are really not the concern of this article.

Furtwängler's early career can only be described as meteoric. Within seven years, he attained the dream of every conductor in pre-war Germany: leadership of the Berlin Philharmonic Orchestra. The first step in this direction took place in 1915 when he succeeded outgoing Artur Bodansky as operatic and concert conductor at Mannheim, a post that had been created in 1779. From there he migrated to Vienna, then to Berlin as conductor of the State Opera Orchestra. In 1922, he followed Nikisch as leader of the Gewandhaus concerts, and finally took over the Berlin Philharmonic.

Such a phenomenal rise seems to belie the fact that Furtwängler was essentially naive in his business relations. Timid, sensitive, wrapped up in his own thoughts, he was guided—or rather led—into an even more powerful position by his shrewd general secretary, Berta Geissmar. He was about to accept the Vienna State Opera directorship starting with the 1929 season when Fräulein Geissmar brusquely interrupted a handshake on the agreement between the conductor and the Viennese manager, and hustled Furtwängler back to

\* 26 West Ninth St., New York 11, NY.

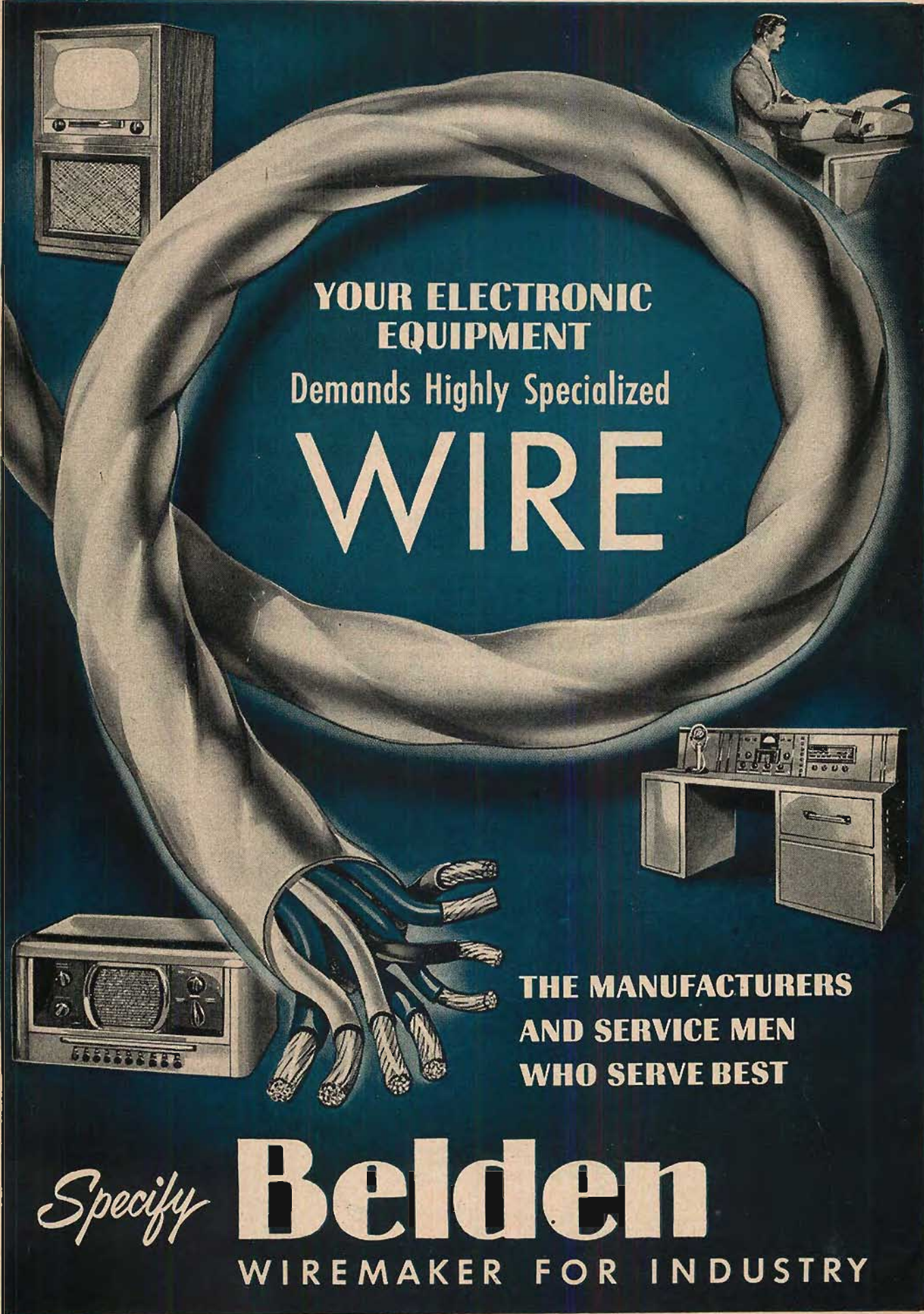

**YOUR ELECTRONIC  
EQUIPMENT**  
Demands Highly Specialized  
**WIRE**

**THE MANUFACTURERS  
AND SERVICE MEN  
WHO SERVE BEST**

*Specify* **Belden**  
WIREMAKER FOR INDUSTRY

Exciting High Fidelity Firsts!

# INTERELECTRONICS

Now . . . in these superb matched instruments . . . enjoy the foremost advances in High Fidelity . . . startling realism, greater power, lowest distortion, precision craftsmanship.



INTERELECTRONICS  
"Coronation 100"

**40 WATT Amplifier \$99<sup>50</sup>**

Greatest amplifier buy today and here's why. RESERVE POWER — 80 watt peak. EXCLUSIVE NOVALOOP CIRCUITRY — completely new, non-ringing multiple path feedback design, over 50 DB feedback. 40 WATT HIGH EFFICIENCY, WIDE RANGE OUTPUT TRANSFORMER — sealed multiple-section winding, thin strip core. FOOLPROOF DAMPING CONTROL — continuously variable, exactly matches loudspeaker for startling performance. 5 to 200,000 cycle response. DISTORTION FREE — less than 0.05% at 30 watt level, ex-

ceeds FCC requirements for FM broadcasting. POWER RESPONSE—at 30 watts  $\pm 0.1$  DB from 16 to 30,000 cycles. HUM AND NOISE LEVEL—virtually non-measurable. DESIGNED FOR THE FUTURE — finest sealed components mounted on Bakelite terminal board for decades of trouble-free listening pleasure. Plug-in filter capacitor. Critical networks of precision components, lifetime encapsulated. BUILT-IN PREAMPLIFIER POWER SUPPLY. BUILT-IN POWER FOR NEWEST ELECTRO-STATIC TWEETERS. Other firsts.



INTERELECTRONICS  
"Coronation"

**\$79<sup>50</sup>** CONSOLE PREAMPLIFIER-EQUALIZER

Worthy companion to the incomparable "Coronation 100" 40 watt amplifier. ADVANCED EXCLUSIVE CIRCUITRY — the only preamplifier-equalizer operating entirely thru negative feedback. REVOLUTIONARY NEW INPUT TUBE, Z-729, phenomenal low noise followed by premium 12AY7 tube. HUM INAUDIBLE with all controls on full. DISTORTION FREE—virtually non-measurable, exceeds FCC requirements for FM broadcasting. 5 to 200,000 cycle response. HIGHEST GAIN — no transformers required with all present phono cartridges. LOUDNESS CONTROL—continuously variable to your exact pref-

erence. MAXIMUM BASS AND TREBLE COMPENSATION — over 20 DB distortion-free boost and attenuation. FIVE INPUT SELECTIONS. 16 PRECISION PLAYBACK CURVES — lifetime encapsulated precision plug-in networks, instantly replaceable if equalization curves change. ULTRA COMPACT, EASY MOUNTING. Built-in power for Weathers cartridge, film projector photocells, condenser microphones. Distinguished satin-gold LUCITE front panel. Custom finished table cabinets available. Many extras.

For the hi-fi thrill of your life, hear the Coronation Twins today! Some dealerships still available.

INTERELECTRONICS  
2432 Grand Concourse  
New York 58, New York

Berlin to think it over. When the Berlin officials attempted to persuade him to turn down the Viennese offer, Furtwängler (acting, no doubt, on his secretary's advice) drew up an ultimatum. He declared that only if the Berlin Philharmonic obtained a government subsidy, and gave him sole authorization over the hiring of musicians, would he consider remaining in Berlin; otherwise he would go south. Berlin saw to it that he stayed.

His relationship with the Nazi government was less successful. In choosing to make music under the new regime (for which fact alone he was condemned), Furtwängler was compelled, as the nation's leading conductor, to pay homage to the authorities. There were many disagreements: Furtwängler refused to go along with the Aryanization policy by protecting Jewish musicians in the orchestra; he also disobeyed a ban on Hindemith's music by giving the first performance of *Mathis der Maler* in 1934. But, eventually, the Nazis won out on these and other points. After the war, Furtwängler quickly regained his position of prominence among European conductors.

So much for the man's career. As a conductor, Furtwängler was anything but a baton virtuoso. His beat—if it could be called that—was an absolute enigma to all players until they got used to it. A member of the London Philharmonic once declared that it was "only after the thirteenth preliminary wiggle" that his baton descended. His gestures were often clumsy, and his height seemed to accentuate an almost gawky neck. Yet once an orchestra began to understand his "beat" and lines of communication were firmly established, the players responded to a man. As Miss Geissmar put it: "When the concert begins he seems to leave behind all earthly things . . . the expressive and directing movements of his hands . . . paint the music on an unseen screen or form it out of an unseen piece of clay. . . . With half-closed eyes he seems to mesmerize the orchestra."

Naturally, Furtwängler's hypnotic effect carried over into the audience as well. This "lean, lonely man quivering the whole of his body" as he directed the orchestra, believed in creating a genuine community in the concert hall so that an "individual is no longer a separate entity, but a part of humanity, a part of the Divine Nature operating through him."

This is only one of the many concepts underlying Furtwängler's approach to his art. If it smacks of the Romantic age, the resemblance is not purely coincidental. For Furtwängler was at heart a creature of the nineteenth century. Everything points to it: the repertoire that suited him consisted of Beethoven, Brahms, Schubert, Schumann, Wagner and Strauss; his tempi were thoughtful and unhurried; he strove less for sensationalism, or what Wagner called "effects without causes," than for a penetration into the heart of the music. The excitement that developed in a great Furtwängler performance was never peripheral, but grew out of the fibre of the work. There was even something Romantic about his appearance. In his Mannheim days, he used to stroll through the town wearing a long black cape and leading a large dog.

(Continued on page 55)

REVOLUTIONARY NEW CIRCUITRY!





ALBERT PULLEY, *Chief Recording Engineer, RCA Victor Record Division*

*Photo by Arnold Newman*

## “‘SCOTCH’ Brand High Output Tape meets all our demands for RCA Stereophonic recordings.”

ALBERT PULLEY, *Chief Recording Engineer, RCA Victor Record Division*, holds an enviable position in the field of audio engineering. His contributions to the development of high fidelity sound over a period of years have helped establish the United States as a leader in recorded sound. In addition, his brilliant and sensitive supervision of recordings by such masters as Toscanini, Stokowski and Koussevitsky have won him the warm praise of critics and technicians alike.

To meet the exacting standards demanded for RCA Victor “Red Seal” Stereophonic recordings requires the finest recording material available. That is why RCA uses new “Scotch” Brand No. 120A High Output Tape for their original recordings. With no increase in noise or harmonic distortion . . . 133% more output, new “Scotch” Brand No. 120A High Output Tape assures audio engineers clearer, greater dynamic range recordings. Have you tried it?



Reg. U.S. Pat. Off.  
**SCOTCH** Magnetic Tapes  
 BRAND

The term “SCOTCH” and the plaid design are registered trademarks for Magnetic Tape made in U.S.A. by MINNESOTA MINING AND MFG. CO., St. Paul 6, Minn. Export Sales Office: 99 Park Avenue, New York 17, N. Y. In Canada: Minnesota Mining and Manufacturing of Canada, Ltd., P.O. Box 757, London, Ontario.



# EDITOR'S REPORT

## FINALLY—AND AN APOLOGY

**A**FTER MONTHS AND MONTHS of delays—some of which were laid to our door and some to others—the Dorf book “Electronic Musical Instruments” is finally off the press, and we have actually held copies in our hands. Many readers thought that we had developed a new racket, it appears, and a few came just short of accusing us of running a modern form of shell game. But the books are now being mailed out and you who have waited so patiently—or otherwise—will have them within a few days. To all, our most abject apologies. Our respect for book publishers has increased immeasurably, since a six-month delay is almost unheard of in those circles. At least, we have learned a lesson—never again will we announce the availability of a book on a certain date until the entire approved page proofs have gone to the printer. Too many things can go wrong from the time the original manuscript is in our hands and actual delivery date.

In spite of the long wait, we believe the book will answer the desires of many of our readers who have been interested in electronic organs since 1947 and 1948, when we published a number of articles by Winston Wells, Mr. Dorf, who has made a specialty of electronic musical instruments for a number of years, has turned out an excellent book, we believe, and hope that its readers will consider it well worth waiting for.

## A REMINDER

Just to refresh the memories of audio people and manufacturers of audio equipment, we are running this month's Employment Register right here on this page where everyone is most likely to see it. This service is a monthly feature—when anyone announces he is looking for a position or when an employer signifies an interest in locating someone with just the right qualifications for a position that is open. There is no charge to industry for this service, nor is any charge made to members of the Audio Engineering Society who are looking for a new connection. Heretofore we have not accepted Position Wanted announcements from non-members, since the Employment Register was operated by a committee from the Society. It is recognized, however, that many who are not members of the Society may occasionally find themselves in search of employment. For them, the Employment Register column is now available at a nominal charge of one dollar for each issue in which the announcement is to be run—a charge which is absorbed by postage and clerical work in connection with each insertion. Each announcement will carry an indication of membership, when such is the case, in the form “(AES)” after the job classification.

As before, the Employment Register is open at no charge to anyone offering employment. All such notices must be received by AUDIO, P. O. Box 629, Mineola, N. Y. before the 10th of the month preceding date of insertion. Those who are not members of the AES must enclose one dollar with the copy, and box numbers may be used if desired. Here are the two announcements received for this month:

★ Development Engineers: Leading midwest manufacturer of microphones, phono pickups, and magnetic recording components has immediate openings for experienced Engineers and Physicists having three to five years on electromechanical or magnetic recording devices. Salaries are commensurate with training, experience, and ability. Apply, giving full resume, to Box 201, AUDIO.

● Technician: Desires position with progressive firm where a responsible, experienced, versatile technician can use his abilities to mutual advantage. Over sixteen years of work with audio and other equipment in radio and TV broadcasting stations, theatre film reproducing systems, component manufacturing, recording, transmitters, etc. Maintenance, operation, construction. For resume, address: M. Goldberg, 2652 E. 21st St., Brooklyn 35, N. Y. Telephone NI 8-2092. (AES)

## PICKUP MOUNTING

We are in receipt of a communication from Harold Leak with some relevant comments about the mounting of phonograph pickups for optimum reproduction quality. He says: “It is not generally realized that inaccuracies of  $\frac{1}{8}$  inch in the mounting position of the pickup can be made easily when using a simple type of flat paper or cardboard template usually supplied with pickup arms.”

Not being content with a destructive comment of this type, the ingenious Mr. Leak enclosed a simple cardboard template which should correct this trouble easily. It consists of an L-shaped strip with a notch to fit over the spindle cut in the long leg, which lies flat on the turntable. Height lines are printed on the short leg, which is cut off at the proper point so that it lies flat on the motor board. Vertical lines indicate the drilling points very accurately for the Leak pickup, and avoid the possibility of an appreciable variation which others have certainly observed (and done nothing about) whenever they had occasion to locate a pickup arm with respect to the center of a turntable. We predict that this device will come into universal use as soon as other manufacturers have a chance to see it.

## AM GOOD MUSIC AT NIGHT

WCRB, Boston, reports that their nighttime grant from the FCC has been received and that the station expanded into evening broadcasting on the regular AM band, at 1330 kc, marking the first time that New England has had a station devoted to Concert Music broadcasting on AM at night. The station has been featuring good music exclusively in the daytime for over a year on AM, and on FM at 102.5 mc day and night since early Fall.

Since visiting the Hub city for the New England Hi-Fi and music show in October, we have been envying the residents there, since they have *five* stations devoted to “good music.” Wonder if the networks mightn't take a hint from that kind of interest—or maybe they prefer disc jockeys.

**PICKERING** models **220** / cartridges  
**240**

*The Most Nearly  
Perfect Phono Pickups  
Ever Produced . . .*

they are sold separately for all standard arms or  
mounted back-to-back to make up the famous  
**PICKERING 260 TURNOVER PICKUP.**

MODEL 220—for 78 rpm records  
diamond or sapphire stylus



MODEL 240—for 33 1/2  
and 45 rpm records  
diamond stylus only

MODEL 260—turnover  
cartridge for 78 or 33 1/2  
and 45 rpm records  
(the 220 and 240  
back-to-back)

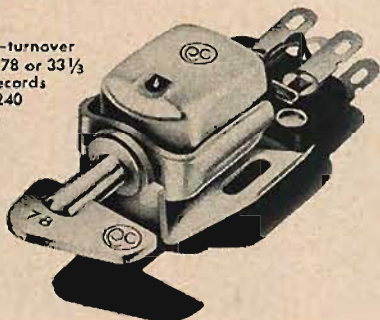

The **220** and **240** are engineered to  
maximize performance. By comparison they  
are without equal . . .

The **220** and **240** are

**Lighter—5 1/2 grams**

**Smaller—5/8 by 3/4 by 3/8 inches**

The **220** and **240** have

**Highest Output—30 millivolts/10cm/sec.**

**More Compliance with Less Tracking Force**

**Lower Overall Distortion**

**Less Moving Mass**

**Wider Frequency Response**

**Mu-Metal Shielding for Less Hum**

These characteristics have real meaning to those who understand that  
maximum performance depends upon components which meet professional  
standards. If you want the best that high fidelity can offer, ask your dealer  
to demonstrate the 220, 240 and 260 Pickering cartridges . . .

*The Most Nearly Perfect Phono Pickups Ever Produced*

**PICKERING** and company incorporated • **Oceanside, L. I., New York**



PICKERING COMPONENTS ARE PROFESSIONAL QUALITY

*“For those who can hear the difference”*

. . . Demonstrated and sold by leading Radio Parts Distributors everywhere. For the one nearest you and for detailed literature, write Dept. A-7.

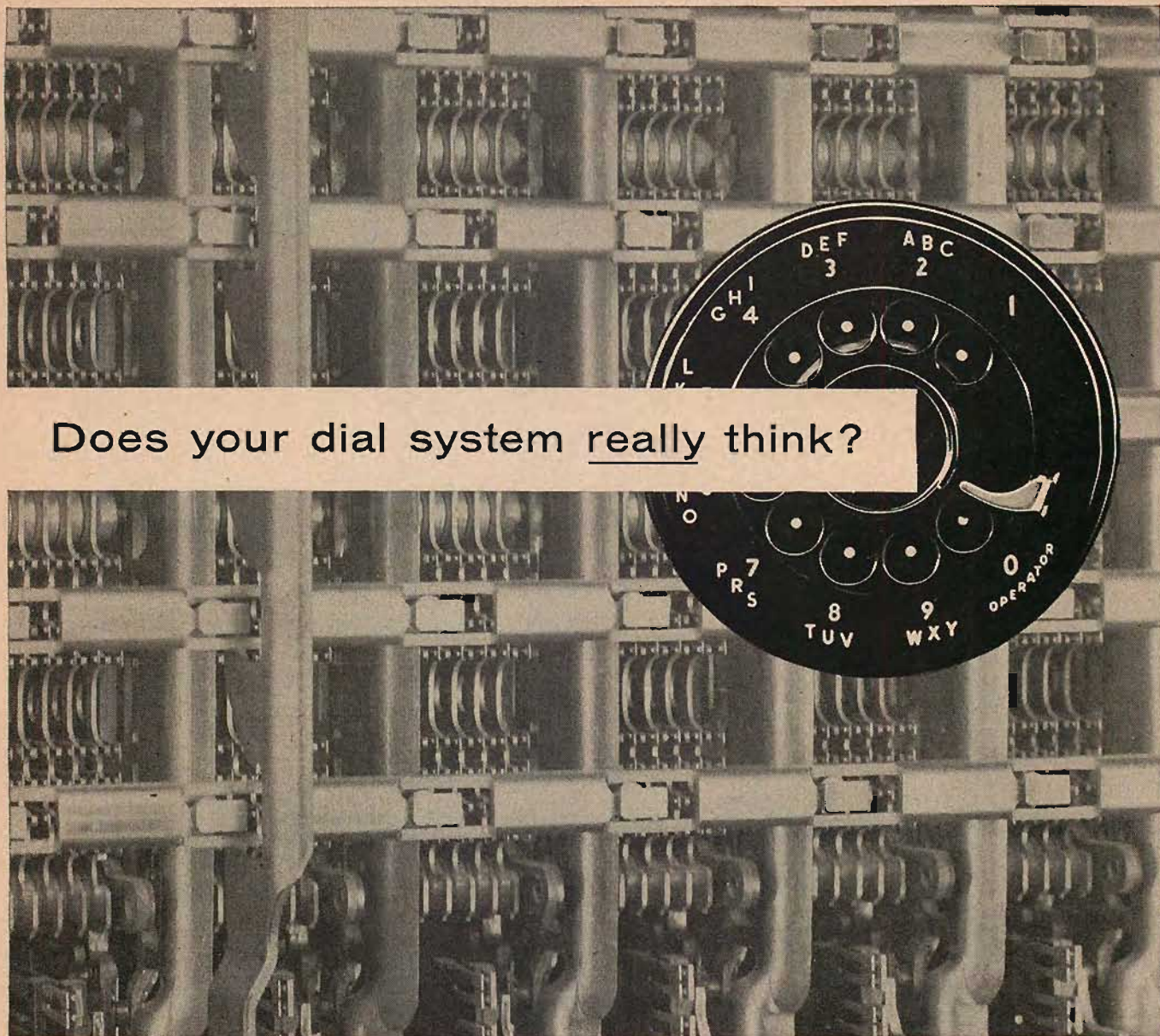

Does your dial system really think?

Part of the control equipment of a modern dial system—dial telephony's equivalent of a brain. It goes into action the instant you dial a call, selecting the telephone you want to reach and directing the switches that set up the connection . . . just as the brain directs the muscular actions of the body.

This question can't be answered until we learn more about the nature of thought. But dial telephone systems *do* simulate many of the processes of the human brain. For example, when a number is dialed, Bell's newest switching system —

**COUNTS** the dial pulses

**REMEMBERS** them

**DECIDES ON** the best route to a nearby town or across the nation

**TESTS** to see if the route is clear

**SELECTS** an alternate if the first route is busy

**REPORTS** difficulties in circuits, if any

Today's automatic switching reflects the creative thinking of many scientists and engineers at Bell Telephone Laboratories. Each year your dial telephone is able to do more for you. And this is but one phase of the continuing effort to keep your Bell telephone service the world's best.

**BELL TELEPHONE LABORATORIES**

IMPROVING TELEPHONE SERVICE FOR AMERICA PROVIDES CAREERS FOR CREATIVE MEN IN SCIENTIFIC AND TECHNICAL FIELDS



# Sound System for Multi-use Auditorium

THOS. R. HUGHES\*

A discussion of the problems encountered in providing a public address system in a typical medium-sized auditorium, and the methods used to solve them without the aid of professional sound-system engineers.

THE PURPOSE OF THIS ARTICLE is to point out the many requirements and problems involved in making an auditorium p.a. installation and to cover their solutions. The installation described is in the new fellowship hall of a church but the same problems are encountered in the entertainment halls of clubs or large banquet halls in restaurants.

This hall is 50 × 80 feet and has a stage for plays at one end and a projection room for handling movie and theatrical spotlight equipment at the other end. Its main use is for banquets followed by programs, and places can be set for 350 plates.

Our primary problem was acoustics. The first public-address system we set up in this hall (a portable system which had served well in our old dining room) was a dismal failure. So we will take up the problems of acoustics and their solution first.

## Out-of-Phase Reflections

Reflection of sound from a smooth plaster ceiling has always been a problem, but vaulted or arched ceilings with heavy exposed trusses usually break up much of the reflection. Since World War II, laminated wood arches and tapered steel I-beam arches have eliminated the exposed truss in architecture for small assembly rooms.

We have found that vaulted ceilings, without the trusses to break up angular reflections, can produce more confusion of speech than a level ceiling, and music projection from direct-radiating loudspeakers at one end of the room is really butchered.

Figure 1 shows how a person at a chosen position in the audience can receive reflected sound from point X on the wall nearest him; from point Y on the ceiling; and directly from the source of speech. The three images are received at different times, making the understanding of speech extremely difficult when the speaker talks fast and clips syllables.

So far, we have just considered the geometric patterns involved. We must

\* 3721 Hillcrest Dr., Los Angeles 16, Calif.

also take into account the fact that understanding of speech is hindered if the high-frequency components are not received in correct proportion to the lows. It is common knowledge among sound men that highs are never reflected from walls of an auditorium to the same extent as the lows.

This loss of highs is a three-fold problem with an indoor public-address system and it is where 90 per cent of the systems prove deficient. As the reader can see, we have not only the problem of the three images being received out of phase but two of them are distorted by loss of highs. And we still haven't considered the effect of the audience.

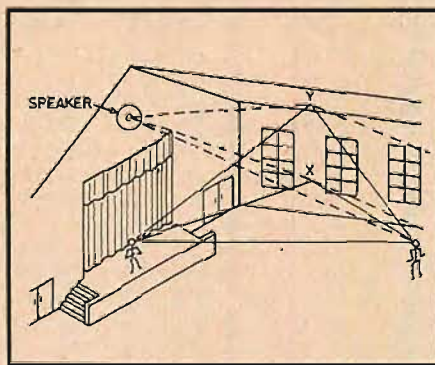

Fig. 1. Reflections of direct sound (solid lines) from speaker to listener in a typical room. Dotted lines show additional reflections from sound-reinforcing loudspeaker.

## Sound Affected by Audience

Anyone who has struggled with indoor PA systems knows that it is difficult to adjust a system in an empty hall. Hum that is distressing in the empty hall is masked by the noise level created by the audience, even when they are being as quiet as possible. And tone quality changes considerably while the clothes of the audience "soak up" much of the sound radiated from the speaker as well as that reflected from the walls.

The nature of the audience—whether they will always be closely seated in permanent chairs or loosely disposed at banquet tables—will affect both the re-

quired sound reinforcing and the tone quality. But, in any event, the reader can see that hearing is a problem in a hall of this size, with or without an adequate sound system.

Of course, the most desirable solution of the major problem is to build the room with adequate acoustical treatment of walls and ceiling. This is nearly always impossible for financial and decorative reasons.

In the hall we are discussing, we often notice that when two or three people are working in the empty hall, preparing for functions, some voices can hardly be understood at distance of 40 feet or more because of confusion of syllables. But one can walk up to the mike and speak to them through the p.a. system in an ordinary tone of voice in the empty room and they can understand perfectly and with no listener fatigue at almost any position they happen to be.

With an audience of 100 to 150 persons grouped near the platform and with a speaker who projects his voice and doesn't talk too fast, we find the p.a. system is often unnecessary because of the corrective effect of the audience. With larger gatherings, however, the audience soaks up too much of the sound before it reaches the farthest seats. Usually more than one person is on the program with questionable ability for making his voice heard.

## Acoustical Feedback

The average application of indoor p.a. systems produces a three-fold deficiency in high frequencies at the listener's ears. In the first place, as previously mentioned, the lows are reflected off the walls and compound their effect at the listener while the highs do not. So he loses a little there before the p.a. system is turned on. This is called acoustical discrimination.

Then, taking up the components of the p.a. system, the first mistake is usually made in choice of microphone. Naturally, if it is to do justice to the overtones, its normal pickup range should extend to around 10,000 cps. But, in our predicament, its pickup pattern is of equal importance.

Outdoors or in a large hall seating 2,000 people, the pattern isn't especially



Fig. 2. Placement of trumpet horn in organ-loft opening, and fairing with plastic material to prevent reflections from inside of aperture.

important. But we have already emphasized the fact that our small hall is very live, with the sound bouncing at the listener from every direction.

In an omnidirectional or bidirectional (figure-8 pattern) mike is used, the low frequency sound is returned and re-emphasized through pickup of reflection from the walls. Of course, if this is allowed to proceed to any degree, the acoustical feedback sets the p.a. system into ringing and finally an unbearable oscillation. Even if it doesn't reach this stage, the listener is getting another dose of emphasized low frequency.

A unidirectional (cardioid pattern) mike with a generous frequency range is usually the first requirement.

But even a unidirectional mike must be protected from the surfaces behind the speakers or performers. It is usually used in front of the soft stage curtains or flimsy stage scenery, which absorb the energy of the lows instead of reflecting.

#### Direct Radiation Pattern

So far, we have considered reflections from the physical properties of the room but now we come to the second offender in the loss of highs by a p.a. system. What about the reinforced sound the loudspeakers are generating?

The reader is no doubt familiar with the fact that all electromechanical transducers project the highs forward in a relatively narrow beam while they spread the lows in a broad pattern. Below 500 cps, there is enough energy in the sound wave to bend (refract) it around the edges of the proscenium arch and into the stage cavity in its attempt to assume a spherical pattern.

From this fact it is seen that we are concerned both with the projected sound that is returned from the walls and that which finds its way directly from the loudspeaker to the mike by refraction. Thus we can have trouble from

acoustical feedback with even a cardioid pattern mike if ordinary cone speakers are mounted on the wall containing the proscenium arch of a stage and the mike is placed out in front of this wall. Or, in extreme cases, low-frequency waves from the loudspeakers refract into the stage cavity and reflect from hard objects into a cardioid microphone.

This is one reason for objecting to the use of ordinary cone speakers for reinforcing speech. Another reason is unsatisfactory range of frequencies and the tendency to produce peaks in the sound level (frequency discrimination) at the middle frequencies. If proper balance of the highs is to be achieved, a tweeter and a dividing network are necessary.

#### Horns Solve the Problem

In this fellowship hall and our main auditorium for Sunday services, we finally came to the use of horn-loaded diaphragm speakers. Some second-hand trumpet-type, straight exponential-flare horns were available and one was used for each hall. Their rated cutoff frequency is 115 cps and they were fitted with drivers having a range from 90 to 10,000 cps. The diameter of the horn opening is 30 inches and the length is 6 feet.

These horns prove to be as near the ideal as possible for several reasons. We could probably obtain the same results with well-designed re-entrant horns flared for a cutoff at 200 cps or preferably lower. Both the horn (if re-entrant type) and driver must be of high-quality design.

Among the advantages of a horn-loaded diaphragm is its smooth performance over the whole range. It smooths out the peaks usually found in the response of a direct-radiating cone speaker and eliminates the need for a tweeter and dividing network. With the woofer-tweeter combination there is always the problem of balancing the two response levels at the crossover region.

The greatest benefit of the horn is its sound projection pattern, which is approximately pear-shaped with the wide end of the pear away from the horn. This is advantageous with a high ceiling or arched ceiling, such as ours, but would be of no use in a basement or low ceilinged room. With a low ceiling, the only chance is to use several small cones dispersed over the area and operated at low volume levels.

The axis of the horn in each hall was aimed at the floor in the center aisle just ahead of the rear wall. This spreads the base of the pear nicely across the rear seats of the room, where the full force is needed most. As one moves toward the front its sound level gradually falls off fairly evenly across the room. At the stage end there is a nearly dead zone for hearers directly under the horn and subtending an arc that reaches across the front of the room and falls back a few feet along each wall, where viewing of movies is also impossible.

This dead zone is such that a stranger,

using a mike on the stage, thinks the sound system is dead and asks the audience if he's being heard. But, reverting to our previous discussion of problems with acoustical feedback into the mike, the reader will see where this dead zone has eliminated much of our troubles. An omnidirectional mike still can't be used at normal levels in the new hall, though, because of reflection of lows from the walls, but there is at least a 100 per cent improvement in the overall acoustics.

This can be understood if we look again at Fig. 1. With the horn near the ceiling its boosted radiation strikes the wall and ceiling at X and Y with angles of incidence such that the reflection from X hits the floor and the reflection from Y hits the back wall. We had previously tried two horns near the walls instead of the one at the center and the results were not nearly so good.

Figure 2 shows how the plastic laminate process was used to couple the flare of the horn to the sides of the only opening available in the main auditorium. This is an opening from the organ loft, high in the left corner of the room, and the angle of the horn was such that some of the sound would have been caught by the right side of this opening and reflected back into the horn, causing distortion.

Plastic laminate is the compounding of layers of glass fiber cloth and plastic to make a solid skin, as stiff as the wall of the horn. The first layer of cloth is cemented to the inner surface of the horn and tacked to the opening at its edges. Plastic (as a powder) is mixed with a liquid agent and spread generously over the cloth. After setting a few minutes another layer of cloth is laid over the first and the process continued. Such a process is used for the skin of guided missiles and body and fenders of some sport cars.



Fig. 3. "Keepaway" mike and manuscript stand which prevents speakers from hugging the mike.



Fig. 4. Wallbox housing for small preamplifier located near the stage to feed a long line to projection room and main amplifier.

### Microphones

The majority of meetings in the fellowship hall are built around luncheons or dinners. The chairman or master of ceremonies has to call on various people for reports or make frequent introductions. So, an ordinary dynamic mike is provided on a desk stand at the chairman's place at the table. This mike is operated at a very low level to get away from acoustical feedback and table noises. The chairman has to pick it up and talk up against it in a normal voice in order to be heard. So it can be a switched or unswitched type.

The other mike, for general-purpose use at normal operating level, must be a unidirectional or cardioid type. A high-medium-low impedance model is desirable because it can be used with a long line by switching to the low-impedance position and plugging in a line transformer just ahead of the amplifier.

When a speaker stands too close to the mike, every move of his head changes the pickup of his voice. We solved this problem by mounting the mike on a reading stand which we designed especially to suit our needs. Figure 3 is a picture of this stand in use. It is made from standard electrical metal tubing with a 20-gage sheet-metal top and trussed with 3/16-inch rods threaded through lateral tubing spreaders. This makes it light enough that it can be carried with one hand.

The sloping top is 16 inches from the front edge to the back and serves a two-fold purpose—providing a place for the speaker to rest his notes, and keeping him a normal distance away from the mike. The edge of the top nearest the speaker is 41 inches above the floor and the mike is centered at 53 inches above the floor. This proves to be a fair average for men and women. The stem that the mike screws on is threaded 5/8-27 and can not be raised or lowered. Below the mike is a shock mount which is a necessity with the regular stand when people start handling or adjusting the mike.

### Mixing Preamplifier

At the time of building, various communication and remote-control lines were run from the stage back to the projection room. A 2-conductor "Romex" was provided for speaker cable and a 2-conductor armored cable (BX) was strung for the shielded cable between amplifier and preamplifier. Figure 4 shows how the preamplifier was installed with its power supply in a locked wall panel on the stage.

On the other side of this wall, a closet is provided in an anteroom for storing the mike stands and other movable equipment. A 4-wire circuit from the projection room terminates in this closet. This circuit is used for 3-way switches in the closet and the projection room so that both the amplifier and preamplifier can be turned on or off at either location. An indicator light shines through a red jewel in the door of the closet when they are on.

Figure 5 shows how microphone-cable jacks were mounted under hinged door covers at the front edge of the stage. From these jacks, 2-conductor

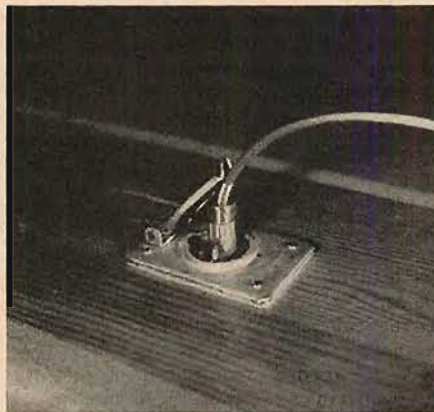

Fig. 5. Microphone plug mounting in stage floor.

shielded cables are run under the stage to the preamplifier. This line from the main microphone and the line to the projection room are connected to the

preamplifier by 2-prong shielded connectors.

The mating of male and female portions of these two connections is transposed so that the mike cable can be unplugged from the preamp and plugged directly into the line to the projection room. Thus the preamp can be bypassed if it develops trouble. In this event, the line transformer is inserted in this line just ahead of the main amplifier. The output of the line transformer is then plugged into the extra mike channel of the amplifier and the switch on the mike is turned to its low-impedance position.

Figure 6 is a schematic of the preamp circuit, which provides controlled mixing from two mikes and uses cathode follower output to the line. Small war-surplus shock mounts were used for mounting the preamp chassis in the panel, to avoid microphonics from action on the stage.

The stage lights and curtain are controlled from a room above the anteroom, where the operator can look out over the stage scenery. Another mike cable extends from the preamp panel to a connector in this room. It is anticipated that a mike may be mounted on a boom to swing back and forth over the stage when plays are put on with the weak voices of children or junior teen-agers.

### Main Amplifier

The main amplifier is mounted in the projection room at the rear and above the hall because it is out of the way there and locked up from the kids. It is in a good vantage point for the operator without making him conspicuous. There is plenty of room there to spread out a radio tuner or record player and records. And finally, the movie projector sound pickup is fed through our amplifier when it is used there.

The quality of sound recording on many of the 16-mm religious and the trade promotion movies is much inferior to that of the professional films.

(Continued on page 52)

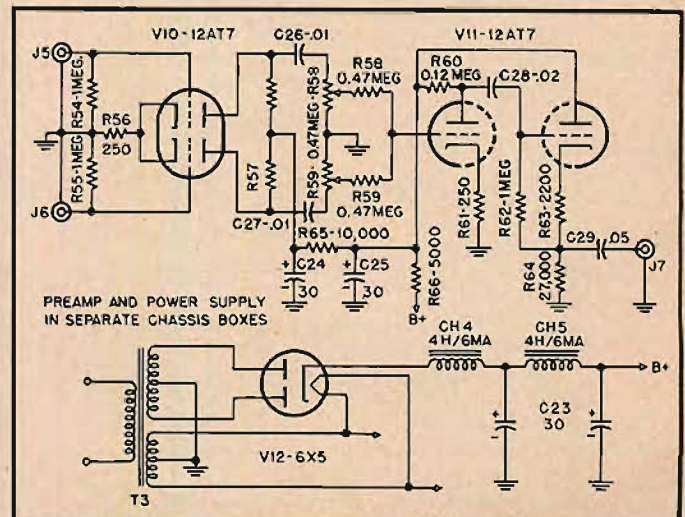

Fig. 6. Mixing preamplifier schematic for unit shown in Fig. 4.

# New Approach To Miniature Preamplifier Design

ARTHUR J. ROSE\*

Simplification of design requirements is said to yield a small and inexpensive unit with performance just as satisfactory to the ear as more standard products.

**A** STUDY OF manufacturers' specifications and of the technical literature will reveal that the major differences between phonograph preamplifier designs is mainly a matter of styling. The general preamplifier design recipe as usually followed calls for the following:

1. Equalizers for Recording Characteristics.
2. Means for switching inputs.
3. Gain control.
4. Frequency correction for room acoustics, speaker system variations, and human hearing discrepancies.
5. Means for overcoming system flaws, e.g. turntable rumble and record noise.

A restudy of the manner in which these goals are reached has shown that much can be done toward simplification of circuits, based on eliminating what is really superfluous even though "necessary" from the standpoint of convention. Once the absolute minimum requirements have been established, it is only a matter of fulfilling them with as little extravagance as possible. The problem of educating those who will

benefit from the simplification is another, more difficult, matter.

In accord with this thinking—and in flagrant violation of convention—a pint-sized preamplifier was developed by the writer. It fulfills admirably the purpose generally served by larger, more complex units. The reduction in the number of parts brings the cost to an uncommonly low figure.

### Frequency Correction

Bass and treble controls are usually thought necessary because of room acoustic and speaker-system variations. These are unchanging once the system has been installed in a particular location. Why, then, is it not possible merely to fix the positions of these controls after installation and then rely solely upon the record equalizer to match each record type to the corrected system? Overlooking the loudness versus hearing difficulties for the moment, the answer is rather obvious: equalizers do not adequately correct from record to record.

What record manufacturers do to their products is purely a matter of speculation. All the user has is a recommended playback curve. Before the average record sounds right the listener must do more than just switch in this

particular curve. That in itself suggests that equalizers need more flexibility.

Fortunately, the type of correction afforded by certain bass and treble tone controls closely parallels that of the record equalizer. It appears that equalizers that do not have the flexibility of continuous variation around a particular characteristic might just as well be replaced by a fixed reference curve and then adjusted to suit the circumstances with a properly designed separate set of bass and treble controls.

This seemingly unscientific fact has met some stiff resistance from those who claim they must have *some* place in the preamplifier where the signal is exactly the same as that entering the recording microphone. Their point is admittedly only an academic one, since they also admit that this condition has little bearing on the correctness of reproduction—particularly if tone controls are not constantly adjusted. The solution to the matter really lies with the problem of "a properly designed set of bass and treble controls."

Another point—more practical but also more subjective—lies in the fact that most records worth playing through a high-quality system in the first place are of recent vintage. The majority of

\* 300 Broadway, Dobbs Ferry, N. Y.

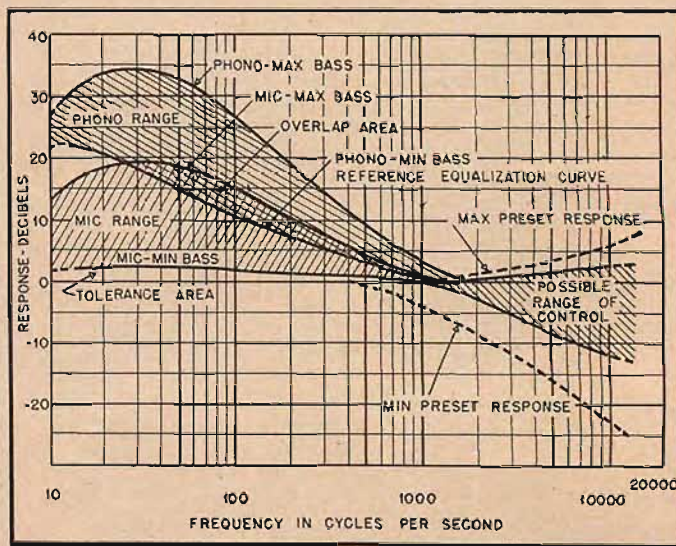
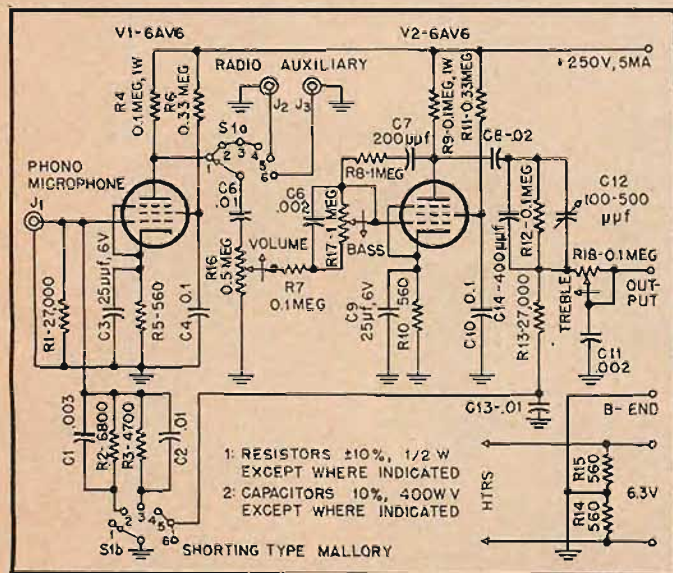

Fig. 1. (left) Schematic diagram of the 2-tube miniature preamplifier. Bass and treble controls are controlled by concentric shafts as the knob arrangement of Fig. 3 indicates. Fig. 2. (right) These curves show the maximum equalization ranges of the preamplifier and the reference curve discussed in the text.



the current recordings are very similar and there is promise that the RIAA "standard" may really become a standard!

Most recordings are made with a 500-cps bass turnover. In some cases there is bass pre-emphasis that requires a flattening of the playback curve below 50 or 100 cps. Treble pre-emphasis is usually at a fixed rate approaching 6 db per octave, with time constants ranging from 50 to 100 microseconds. For reasons made evident later, the writer's miniature preamplifier uses a straight 500-cps turnover without de-emphasis as a fixed reference curve.

To reduce the circuit to a minimum, only those functions that can be justified as essential are included. There is only a rare need for bass rolloff, especially at low and medium volume levels. A fortuitous circuit arrangement permits some bass droop at higher volume settings, but requires only the components for boost.

Need for large amounts of bass boost at low volume levels to produce proper scaling of sounds that were originally loud has given rise to loudness controls. Although their use has been justified more by the whims of bass-crazed audio hobbyists, it is desirable to have sufficient boost available to cover extreme conditions. The actual loudness correction to be used is subject to variation depending upon the relationship between the playback and the original levels, with due consideration to individual hearing. It is evident that there are a great number of possible circumstances and any compensation fixed solely as a function of playback level would prove to be incorrect in most of them.

Using terminology which divides hearing and acoustic corrections into two functions is paradoxical. It would be interesting to learn how someone in average circumstances can make a purely acoustic correction without benefit of hearing. Even sound-level meters are fitted with frequency-weighting networks to simulate the response of the human ear. Both acoustic and hearing correction can be and are made simultaneously, provided the maximum bass response is adequate.

The similarity of characteristics used as a basis for lumping corrective measures is more than just fortunate. It suggests to the writer that some types of correction may be imaginary and other types need stronger emphasis. Or viewing from another angle, there can be only one ideal resultant correction curve for a given situation, and a much smaller range of variation is needed to cover most situations than would be supposed.

Obtaining a large amount of bass boost can prove to be difficult if one wishes to reduce circuitry to a very simple form. Making allowance for normal boost requirements plus that needed for low levels has been solved by the writer with a simple circuit that applies a sort of automatic correction so that theoretical limits of boost are actually attained. This circuit has been used with success in supplying an 8-in. speaker

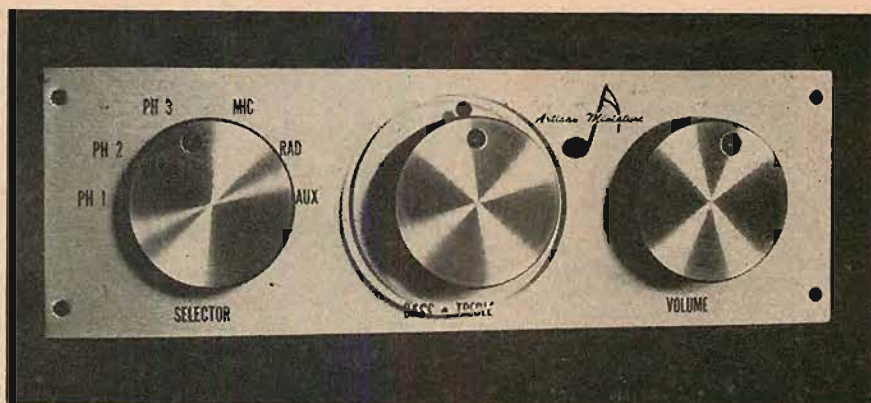

Fig. 3. As constructed by the author, the preamplifier is built in an aluminum box with this aluminum panel on the front. The outer shaft of the concentric bass-treble control is operated by a Plexiglas disc.

with sufficient low bass to rival much more formidable systems. In itself, this fact shows that the need is only for improvement in circuit efficiency in most cases where bass is lacking, rather than for additional circuits.

In accord with this trend of thought, all functions related to the bass region are combined in the miniature preamplifier in one circuit, with a single control governing whatever adjustment is necessary. Figure 2 shows its range.

#### Treble Correction

Treble compensation can be simplified in like fashion. It has been general practice to apply 50 to 100 microseconds de-emphasis in the equalizer, and then by use of the treble control apply up to 75 microseconds further de-emphasis or emphasis. It is easy to see that some saving can be made by not including de-emphasis in the equalizer. This entails applying a variable de-emphasis to a response with fixed treble boost.

For example, a recording with 50 microseconds pre-emphasis initially has treble boost to the extent of 10 db at 10 kc. Why de-emphasize it to a flat

response and then boost or droop it  $\pm 15$  db? The same effect can be had without initial de-emphasis if the signal is fed into a system with a +5-db boost. Then, application of only rolloff to a maximum of 30 db will produce the desired result.

That sounds simple enough but there are some apparent drawbacks. De-emphasizing to the extent of 30 db in a simple circuit involves reducing amplitudes below the midfrequency region. This occurs because a single R-C network has a maximum slope of 6 db per octave. Another seeming drawback is that recordings vary in the amount of pre-emphasis, and radio inputs and some recordings have no pre-emphasis at all.

To justify intuition on the part of the writer, listening tests were conducted using a wide variety of recordings and program material with a considerable variety of associated equipment. In no case was there need to vary the treble response more than 15 db! It appears that all that is required for most purposes is a certain maximum response depending upon the associated

(Continued on page 69)

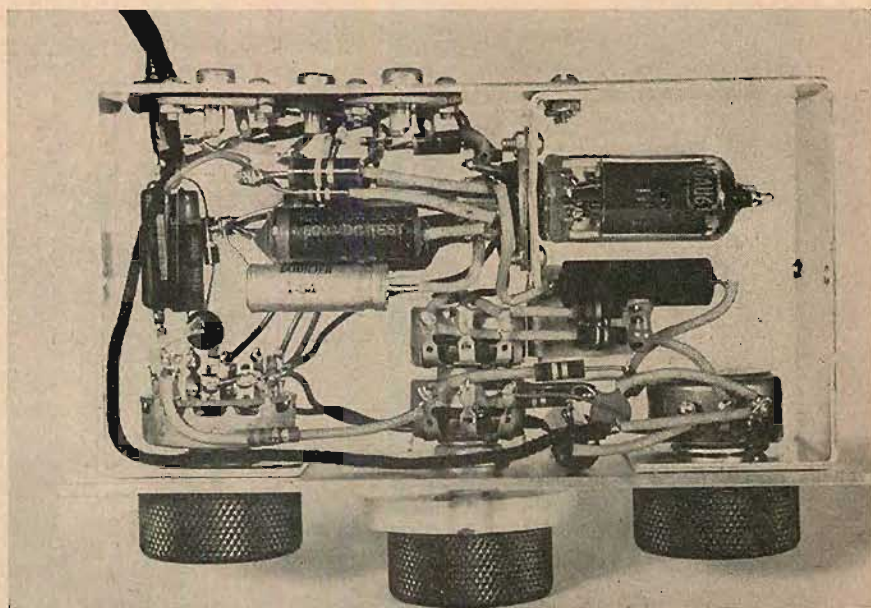

Fig. 4. Interior of the preamplifier. Size can be judged by the tubes. Even though the panel is just about large enough to accommodate the controls, there is plenty of space inside for components and wiring.

# Japan Goes Hi-Fi

WARREN BIRKENHEAD\*

Good audio isn't exclusive to the United States—it is rapidly gaining a foothold in Japan, too.



**A**BOUT ONE YEAR AGO, LP disks began to emerge in quantity from the pressing plants of certain Japanese record companies. And while the initial production was a painful process, with two pressings going into the scrap barrel for every one accepted, technical difficulties were soon overcome.

Since there were no Japanese manufacturers selling phonographs capable of reproducing LP's, the phonograph and record buying public interested in hi-fi consisted mainly of those Japanese

\*18310 Kingsdale Ave., Redondo Beach, Calif.

and those members of the United States armed forces stationed in Japan who could afford the imported articles.

Today the situation is far different. A considerable number of 2- and 3-speed Japanese-made LP phonographs are on the market, and hi-fi components are available. All of the record companies are in acceptable microgroove record production.

American record labels can be found in any record store in Japan. All of the major American companies have associate Japanese companies who press and market American records. Mother matrices are air-shipped from the States

to be converted into stampers and pressings by the Japanese associate companies.

The Japanese pay the Americans a royalty based upon the record retail sales. It is interesting to note that approximately 50 per cent of all records sold today in Japan are of foreign label, and largely American. It is estimated that total Japanese record sales for 1954 will top 30 million.

Hi-fi sets in use in Tokyo alone today are estimated at more than 50,000. These installations are estimated at an average of \$90 each. Considering the fact that more than 95 per cent of the Japanese



Above, Listening Room "Matsuya" Department Store, view from speaker end to rear. Notice the complete lack of the other sex!

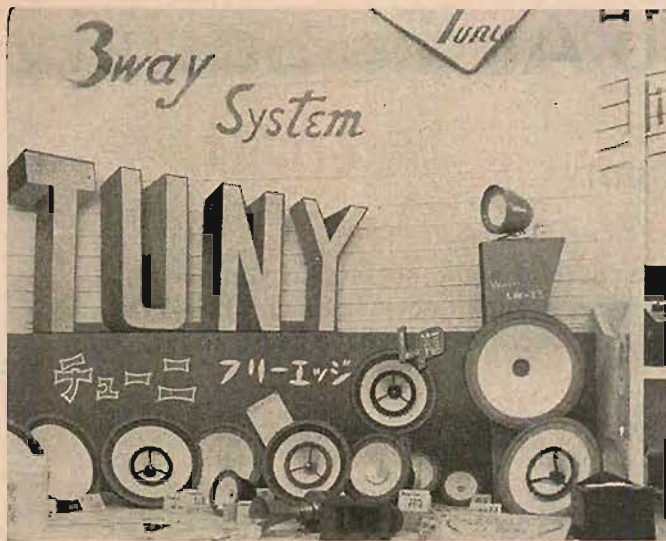

Left, loudspeaker display from Hark K.K. Right, sapphire needles displayed by Nagaoka Seiki K.K.

hi-fi enthusiasts build their own amplifiers and assemble their own hi-fi systems, and considering the lower component cost in Japan, this average cost is comparable to an average Stateside cost of several times that figure.

In the Kanda area of Tokyo—just north of the famous Ginza—one can browse through more than a hundred retail stores that sell hi-fi parts. Loudspeakers, amplifiers, amplifier parts, pickup cartridges, turntables, preamplifiers, and equalizers are all in abundant

supply by many manufacturers, and are hawked in the many stores throughout the day and night.

One enterprising Kanda hi-fi store has set up a coffee shop on the second floor above his establishment. There, prospective hi-fi customers, while drinking coffee, may listen to LP's reproduced through the various loudspeakers, amplifiers, and pickups which are on sale in the store below.

There is always a demand in Japan for parts and equipments made in the

United States. If a store manager can display a Stateside item, he can always be sure of a higher price and a quick turnover. For this reason, there is a tremendous temptation to market Japanese-made articles with a Stateside label. This practice is definitely deplored by the Japanese government and stopped when detected. Reputable Japanese manufacturers and engineers alike join in condemning it. However, the practice is still a factor, and while small and

*(Continued on page 68)*

Scenes in the Hi-Fi Coffee Shop of a Kanda store, where customers taste the delights of quality sound as well as the savor of the bean. Left, coffee-shop proprietor Kinjiro Maruyama inspects playing desk. Above, left to right: waitress, Hideo Iguchi, Nippon Times record columnist, and author. Note speakers in upper left.



# The Poughkeepsie Audio Society

CHARLES R. DOTY\*

The easiest way to learn how to form a successful audio society in your own home town is to study how an already successful group functions. This one—in existence for nearly five years—is one of the most successful we have heard about.

**W**HILE THE SALES of high-fidelity equipment in the year 1950 amounted to but a small fraction of the estimated \$250,000,000 for 1954, there was nevertheless, a definite indication at that time that the interest in audio was making rapid strides. This display of interest was not limited to those who were technically minded and who were interested in high fidelity for its hobby aspects. Included were many who knew nothing about the equipment and its installation but who were interested in securing the high degree of faithful reproduction of music which was available only through custom installation of the various components. A considerable number of people approached the writer and requested his advice. The time spent in discussing the considerations of finance, speaker placement, and equipment arrangement, plus demonstrations of the writer's equipment, was beginning to seriously encroach on his free time for grass mowing and other around-the-home chores and social engagements. No inference should be drawn from this background that the writer is unusually qualified to give advice. His situation is the same as thousands of others who were among the first in their communities to install good equipment and who were, and probably still are, bombarded with

\*International Business Machines Research Laboratory, Poughkeepsie, N. Y.

requests for guidance. The problem in 1950, which still exists in 1955, was how to offer guidance to people which would enable them to make a wise selection of the better grade of components so that the over-all result would be satisfactory.

The only possible way to handle this flood of interest seemed to be through gatherings where people could discuss their problems with others and in this way receive the benefit of their experiences and conclusions. Also, by getting a number of people together, one demonstration would suffice where several individual demonstrations were formerly required. Accordingly, a meeting was held at the writer's home on the evening of June 5, 1950 at which it was decided to form such a group. There were twelve people present at this first meeting of the Poughkeepsie Audio Society. The fact that there are presently 279 men and women in the Society is an indication of the large number of people who are interested in some phase of audio and who are anxious to learn more about the subject through demonstration and discussion sessions.

We purposely avoided the inclusion of the word "engineering" in deciding on a name for the Society as we did not want anyone to feel that our meetings were to be of a predominantly technical nature and thereby be of little or no interest to lay people—for after all, they are the ones who need assistance most. We decided that our organization was

to be devoted to all phases of audio and that all of our programs would include some music for those who were only interested in listening. It is surprising how many of those who just came to listen at first have now become interested in the why's and wherefore's of the equipment. The exposure to the technical aspects of the subject during the first portion of our meetings has created a desire in many members to know more about the basic principles because of their fundamental relationship to the over-all result. For example, the wife of one of our members, who has been attending our meetings fairly regularly, came up to me after one of our recent sessions and said "I am quite proud of myself, I understood everything the speaker said." The talk that evening was an explanation of the recording characteristics of the very latest types of LP records.

Our first regular monthly meetings began in the Fall of 1950. We started very modestly by meeting at the homes of the members and by covering such fundamental subjects as pickup stylus wear, the preamplifier-equalizer and why it is required, the power amplifier requirements, and so on. A portion of each meeting held at a member's home was devoted to listening to records on his equipment. After a few months we outgrew even the most pretentious home quarters and rented a room at the YMCA or local High School. In order to pay for these facilities everyone who attended a meeting paid 25 cents. For the past two years our meetings have been held in the largest quarters of the two local hotels. We now charge 50 cents per person and our average attendance at meetings this past spring has been over 100.

## Operating Procedure

Meeting notices are mailed out about a week in advance of the meeting date. We endeavor to word our notices in such a manner that they will attract the attention and stimulate the interest of both the male and female members of the Society. Letters rather than postal cards are used because they are more personal and convey more information about the program, the speaker, and the equipment to be demonstrated and discussed. Our notices always conclude with an invitation to members to bring along as many friends as they may wish



Charles R. Doty, the author, with his Life Membership Card No. 1 which was presented on the occasion of the Society's first dinner meeting. Mr. Doty was first president, and has served ever since as program director.

because anyone who is interested in any phase of audio is always welcome to attend our meetings. We make a charge of \$1.00 per year if a member wishes to be notified by mail of the meeting night and subject. This charge is necessary to defray the cost of the preparation and mailing of the notices. This who do not wish to subscribe to the mailed notices learn of our meetings through the two local radio stations and newspaper.

Everyone attending a meeting is assessed 50 cents to defray the expense of the meeting quarters and the dinner of the guest speaker. There are no other assessments involved. We have a standing offer that anyone who does not feel that he has received his 50 cents worth from any meeting can get his money refunded at the close of the meeting, providing that he can convince our Treasurer that such was the case. To date there have been no refunds made. On this basis no one should feel that he has an obligation to attend our meetings. We wish every member, or interested non-member, to feel free to attend only those meetings which are of interest to him, or to attend the meetings only as long as necessary in order to secure the information or help he is looking for. In other words, we are interested in performing a service rather than having large turnouts at the meetings. The element of friendship and the opportunity to talk things over (and possibly to brag a little bit about one's accomplishments) is an ever-present force which brings many people out to every meeting. As members leave our rank, others step in to fill their places and so far our membership has shown a continuous growth from year to year.

We make every effort to conduct our meetings as informally as possible and to restrict the business portion to absolute necessities such as the reading of the reports of the Secretary and Treasurer. The officers of the Society make final decisions on all matters of policy or the expenditure of money, so that only occasionally does anything develop which requires the attention of the membership. We have no constitution or by-laws. Announcement of sales of records or equipment by the local stores are made at the meetings. Also announcements are made of topics of interest to our members concerning meetings of other organizations, such as the IRE and AIEE. These matters seldom take more than 10 or 15 minutes, so that practically all of our time is devoted to the speaker of the evening, demonstration of the equipment under discussion and the playing of records for the "listener" segment of the organization.

Our regular monthly programs are presented by guest speakers and representatives of manufacturers of high fidelity equipment. The list of those who have come to Poughkeepsie and presented programs during the past three years reads like a "who's who" at the Audio Fairs. In other words, the leading manufacturers send a speaker (in most cases a loud speaker as practically every



PAS officers for year 1953-54—left to right: Carter S. Ammon, treasurer; John E. Sill, president; David W. Muir, vice president; and Lawrence A. Tate, secretary.

one of our guests has shunned our microphone system) and generally a complete complement of equipment. Of late we have had a series of programs presented by the leading manufacturers of matched components. Our guests are free to present their products in any manner that they desire. In many cases the talks are supplemented by projection slides or blackboard diagrams.

Letters to manufacturers inviting them to participate in our meetings contain sufficient basic information about the Society to permit them to rough out a program presentation. Further correspondence generally follows about the equipment, arrangements for a slide projector when required, and so on. Prior to the meeting, generally during dinner, the speaker is further briefed on the aims and purposes of the Society and the type of people he will talk to so that he can present a well-rounded program which will cover all facets of interest. Following the talk a question and answer period is provided, and then the equipment is demonstrated. In most cases this is done through the medium of records. The selections played are chosen by the speaker to bring out certain features of the equipment which will demonstrate it to the best advantage. During the demonstration part of each meeting we try to play a few selections from the same records (which are provided by the Society) so that a direct comparison of the merits of the equipment can be made from month to month. These records include piano, ballet, and organ selections. One selection which we always request be played as a part of the demonstration is Contrasts Over Pedal, (Study in Overtones, No. 102) by Bartok, Mikrokosmos Suite, record BRS 303. This we consider the "acid test" and guest speaker and audience alike enjoy the reparte.

One should not assume from the mention of the above selection that we go in for the window rattling type of demonstration. On the contrary, we make every effort, and in most cases succeed, in keeping the volume at living room level. We believe that a modern high-fidelity installation is an instrument for reproducing music for pleasurable listening and not for testing the adequacy of the construction of the house or the patience of the family or neighbors.

At the June meeting, which is our annual dinner gathering, the President appoints a nominating committee whose duty it is to select a set of officers for the next year. The selections are voted on at the first meeting in the Fall. We have a standing rule that elected officers can serve only one term.

The elected officers of the Society comprise the President, Vice President, Secretary and Treasurer. The Program Director and all committees are chosen by the President at the time of his election. The President presides at all meetings, dictates the order of business and introduces the speaker of the evening. The duties of the Vice President, Secretary and Treasurer are the same as in other organizations. The Program Director has complete charge of the programs, and makes all of the arrangements with the equipment manufacturer and the guest speaker. The Program Director makes it a practice to secure complete information on all new records played during the meeting in case anyone should be interested in purchasing one or more for his own collection.

It is the custom for all officers to circulate among the members to exchange pleasantries and to greet those attending a meeting for the first time. They also

(Continued on page 70)

# Scaling—

## An Aid in Circuit Analysis

EDGAR D. MORGAN\*

A simple preliminary operation transforms circuit values to numbers much more easily dealt with in computation.

THE DESIGN AND ANALYSIS of audio networks can be a challenging and satisfying occupation. On the other hand, some of the computations required are best described as just plain, hard work. Calculating the frequency response of some networks, for instance, is discouraging enough to make one forego it. The functions often become unwieldy as soon as we insert values for the parameters. This is due mainly to the numerical magnitudes of the elements themselves.

To simplify the expressions somewhat, present-day practice uses a system of exponential powers of ten. Thus, a resistance might be written as  $5.6 \times 10^5$  ohms rather than 560,000 ohms. While this is an improvement on the decimal system, it still fails to eliminate much of the drudgery. A significant step can be made, though, by employing a process called *scaling*.

### What Is Scaling?

Scaling is a technique which changes the components of an electrical network to a more convenient magnitude before computation or analysis begins. Very large numbers can be appropriately reduced and small ones increased. This virtually eliminates the exponential notation and we are faced with a network containing only "nice" values, such as 5.6 ohms, 15 farads, etc. Analysis then proceeds unburdened with awkward numbers. The results are interpreted by an inverse process putting impedance, voltage and frequency concepts in their proper perspective.

The principle point to be noted, however, is that our choice of scaling values is not completely arbitrary. We are, of course, governed by the physical relationships between impedance, inductance, capacitance, frequency, voltage, current, etc. These laws determine which class of components we may freely adjust, and the resultant effect on the other components. The simplification obtained makes it worthwhile to investigate these limitations and to formulate the rules we must observe.

### Relations Between Parameters

Let us suppose we have arbitrarily adjusted both resistance and capacitance by

\*2124 31st Place, S. E., Washington 20, D. C.

a given factor. For instance, we may have reduced every resistance by a factor of 1000 and increased every capacitance by 100,000. This would have the effect of changing a 50,000 ohm resistance to 50 ohms and a 1- $\mu$ f capacitance to 0.1 farad. If any further computations are to yield a useful result, fundamental relationships must hold. In particular, examine the relationship  $\omega = 1/RC$ . It is apparent that we have, by independent adjustment of  $R$  and  $C$ , effected an adjustment of  $\omega$ . In this case, our adjusted angular fre-

where the primed factors indicate adjusted values, and  $a$ ,  $b$ , and  $c$ , arbitrary scaling factors. From this point, we can derive the other relationships between components.

If we ignore vector relations between the quantities, we may drop the operator  $j$  from our calculations. Then, as

$$\omega' L' = Z'$$

we can substitute our chosen values and get

$$L' = \frac{Z'}{\omega'} = \frac{aZ}{c\omega} = \frac{a}{c} L$$

In a like fashion

$$C' = \frac{1}{\omega' Z'} = \frac{1}{aZc\omega} = \frac{1}{ac} C$$

and finally

$$E' = I' Z' = aZbI = abE$$

This covers all the factors needed for most problems, and the results are summarized in Table I.

Dimensionless quantities such as amplification factor and gain are unaffected by the scaling, although plate resistance and transconductance are. The quality  $Q$  of a circuit is unaltered. This can be readily demonstrated for a coil, as

$$Q = \frac{\omega' L'}{R'} = \frac{c\omega \frac{a}{c} L}{aR} = \frac{ca\omega L}{caR} = Q$$

### An Illustrative Problem

A simple problem will serve to illustrate the technique. Let us calculate the midfrequency gain and the half-power points of the R-C-coupled amplifier in Fig. 1(a). The conventional equivalent circuit is shown in 1(b).

If we choose the scaling factor  $a$  to be  $10^{-4}$  then the resistance values will appear as in Fig. 2. An equivalent current generator is indicated, in which

$$g_m' = \frac{\mu}{r_p'} = \frac{100}{8} = 12.5 \text{ ohms.}$$

The three parallel resistances combine to give an equivalent resistance equal to 4.5 ohms and the midfrequency gain is given by

$$A = g_m' R_{eq}' = 12.5 \times 4.5 = 56.3$$

For calculating the high-frequency circuit values,  $a$  remains equal to  $10^{-4}$ . The quantity  $1/ac$  has been chosen as  
(Continued on page 61)

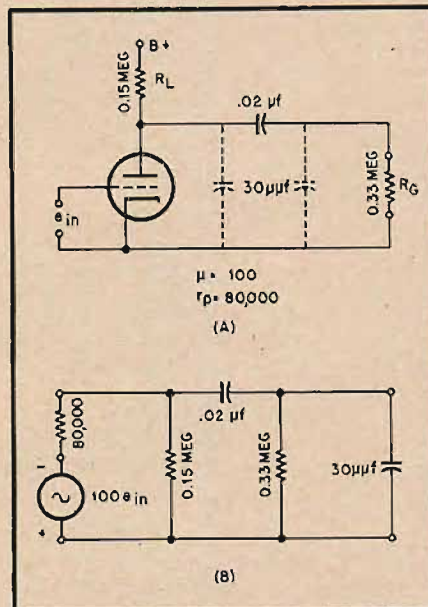
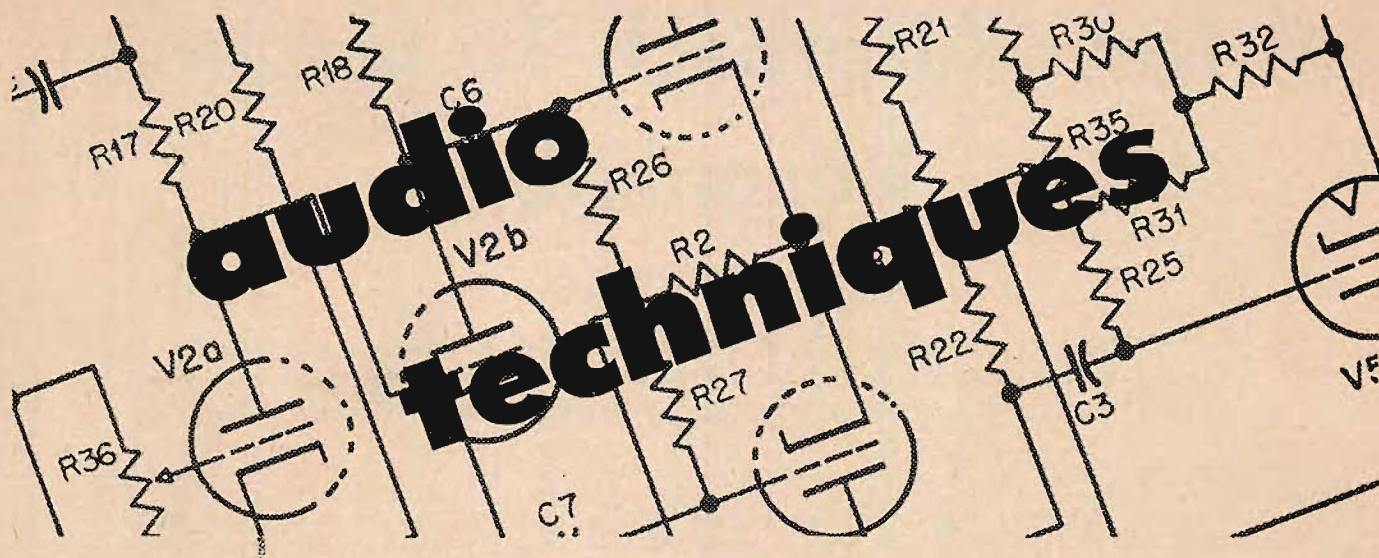

Fig. 1. R-C-Coupled amplifier and conventional equivalent circuit.

quency is 100 times smaller than its proper value. The true value is 200 radians per second, but use of our scaled values indicates the angular frequency as .2 radian per second. This poses no difficulty as long as we recognize this additional adjustment is required to place  $\omega$  in its proper perspective.

As this interdependence between parameters is easily investigated, we can tabulate the possible choices of scaling we have at our disposal. A convenient start may be had by choosing

$$\begin{aligned} Z' &= aZ \\ I' &= bI \\ \omega' &= c\omega \end{aligned}$$



## Some Hints for Broadcast Engineers

R. S. HOUSTON\*

The author tells about some useful "gim-micks" he has devised to lighten the daily load.

### Sound-Conditioning for Plastered Rooms

When confronted with the task of recording a school band inside a concrete room, the task of obtaining proper acoustics seemed insurmountable. Although there was a high ceiling with quite a pitch to it, the major source of reverberation came from the hard plaster and concrete walls, coupled with a concrete floor. There was no money with which to treat the walls with commercial sound board, nor was it considered practical, since the room was so seldom used for recording but merely as a rehearsal room. However, it was agreed that even rehearsals would sound better in a more dead room.

After experimenting with various types of drapes, panels, and so on, it was discovered that the soft pulpboard separators for egg crates were almost the perfect answer. Each one has 36 egg cups of spherical shape which make for perfect diffusion, and the material itself is a good sound absorbent. Since this was an agricultural territory (Colorado), egg-crate separators were practically free. The students themselves undertook the task of applying them to the wall with every sort of glue imaginable, and none has fallen off after several years.

One or two coats of water-mixed paint can be applied without interfering with the surface and finish of the paper. But even if hard-finish paint is used, the shape of the separator is such that diffusion is nearly perfect. By using them with the cup turned out, that is, with the convex side showing, a greater diffusion is obtained. The difference with and without this treatment is almost overwhelming, and satisfactory recordings can now be made.

\* 7723A Broad St., Pennsauken, N. J.

### Remote Air Monitor Speaker

Often there arises a need for the transmitter man on duty to do work away from the building or out in the field—in either case, out of earshot of the monitor speaker. When work is being done on or around the antenna tuner, the method described here will provide positive monitoring without the need of stringing a monitor pair to the location.

It consists simply of a high-level diode monitor driving a speaker directly as

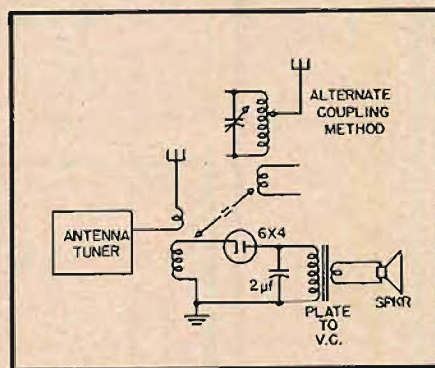

Fig. 1. The air monitor speaker.

indicated in Fig. 1. A 1- or 2-turn loop is used at the cold end of any inductor in the antenna tuner to sample the r.f. in the tower. In the case of a current-fed antenna, the loop could be in the feed line to the tower. A power-type diode such as the 6X4, is used to rectify the r.f. to pulsating d.c. A regular plate-to-voice coil transformer is used to match the signal from the loop to the speaker. A 2- $\mu$ f capacitor is used across the primary of the transformer to bypass the r.f. to ground.

A weatherproof 6-inch projector was mounted on the roof of the tuning house to enable the sound to be heard at some distance. Thus it was possible to be aware of the program and still not be tied down to the building proper. This method drains perhaps 1 watt from the r.f. energy, which is hardly enough to bother about.

### Unattended Remote Without Amplifiers

In the course of experimentation, it was determined that the telephone lines in one town were exceedingly quiet. It came to light when, through emergency, earphones had to be used as both microphone and receiver for a talking circuit. In order to hear the signal from the line it was put through an amplifier at the studio. Surprisingly, there was little noise noticeable. Further research disclosed that with low-impedance microphones the noise was cut down to practically zero—the lower the impedance, the lower the noise. It was also discovered that if the studio input impedance was kept considerably higher, the noise was still further reduced.

The user of this system must remember that while a balanced line will reduce crosstalk tremendously, there is still some susceptibility, so the area through which a given line will travel must be comparatively quiet, particularly free of electrical disturbances. On the several lines the author has had occasion to use, the results have been completely acceptable, and the advantages of not needing an amplifier are many. There is nothing save the line connection to the microphone to worry about. There is no need to fear that nontechnical personnel will forget to turn on the amplifier. And the

(Continued on page 60)

# A New Approach To Electrical Resonance

N. H. CROWHURST\*

A clarification of the subject of resonant circuits presented in a manner that makes it easier to understand the effects of series and shunt connections of inductance and capacitance in combination with each other.

**A**T A RECENT DISCUSSION of difficulties in the teaching of electrical and mechanical resonance at the British I.E.E. some of the sources of confusion were enumerated, and some suggestions, including the present new approach, were put forward with a view of overcoming difficulties. That the conventional approach is unsatisfactory is evident, not only from difficulties encountered during the teaching of this subject, but also from the misunderstandings and fallacies one finds even in the minds of qualified engineers years after the completion of their training.

So long as one is interested in resonance only in a general sort of way, the difficulties remain unnoticed. The general principles that series circuits provide a low impedance, and parallel circuits a high impedance at resonance are easily understood. The difficulties arise when detailed investigation of circuit performance in the vicinity of resonance is required due to the number of quantities associated, the possibilities of different quantities varying, and the choice of phenomena by which resonance is identified. Usually frequency is taken as the independent variable, circuit quantities being considered at least relatively fixed; but some practical applications require a consideration of response as certain circuit elements are varied with the frequency fixed. Whatever is varied, maximum or minimum impedance coincides with the condition for unity power factor, resistive impedance, or in-phase transfer only for special cases. In some arrangements there may be from four to six different critical or reference frequencies associated with resonance.

Part of the difficulty arises because most presentations of the subject either include erroneous statements, or are in-

\*82, Canterbury Grove, London, S.E. 27, England.

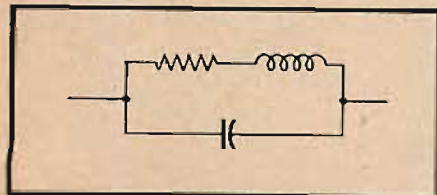

Fig. 1. This is the conventional circuit for considering parallel resonance.

sufficiently explicit in specifying conditions.

The most common fallacy arises from using the circuit of Fig. 1 as the basic or simplest parallel resonant arrangement, and then assuming for simplicity that the resistance may be given a constant value over the range near resonance. In actual fact, as we shall show, resistance often contains a term varying with  $\omega^2$ , which means it can vary more rapidly than the reactance of either L or C. But no one would dream of assuming the reactance of L and C to be constant over a range of frequencies near resonance! "Yes we know," is the usual response, "but one must make simplifying assumptions somewhere in a first approach."

The author agrees; but simplifying assumptions should always follow a channel designed to aid the approach, and should, as far as possible, have some significance in practice.

## Series Circuits

To start with, take the series circuit, shown in Fig. 2. Consider it first with assumed constant current as frequency is varied as in Fig. 2(a). If difficulty is encountered in visualizing the condition of constant current, it can be assumed that current is adjusted to the same value at each frequency before a reading is taken.

Voltage drop across the resistance element  $V_r$  is constant. Drop across the inductance  $V_L$  is proportional to frequency, hence is represented by a straight line at slope proportional to L. Drop across the capacitance will be inversely proportional to frequency, giving a hyperbola.

When the two reactances are equal, the resultant drop is that across the resistance, and unity power factor coincides with minimum (resistive) impedance for this arrangement. There is only one critical frequency, at which both minimum impedance and zero phase occur; there are no other maxima or minima.

Next, transfer this information to an assumption of constant applied voltage, shown in (b) of Fig. 2. Readjustment of value is made at each frequency so that the "curve" for  $V$  is now a straight horizontal line, as a result of which the  $I$  and  $V_r$  curves now peak upwards, instead of being horizontal lines. The voltages across the inductance and capacitance elements also take the form of upward peaks, staggered about the resonant frequency. To make the voltage curve flat, the ordinates from the constant-current condition have to be multiplied by the factors producing the central peak in the  $I$  and  $V_r$  curves. But as both  $V_C$  and  $V_L$  have a slope at the resonant frequency in the constant-current

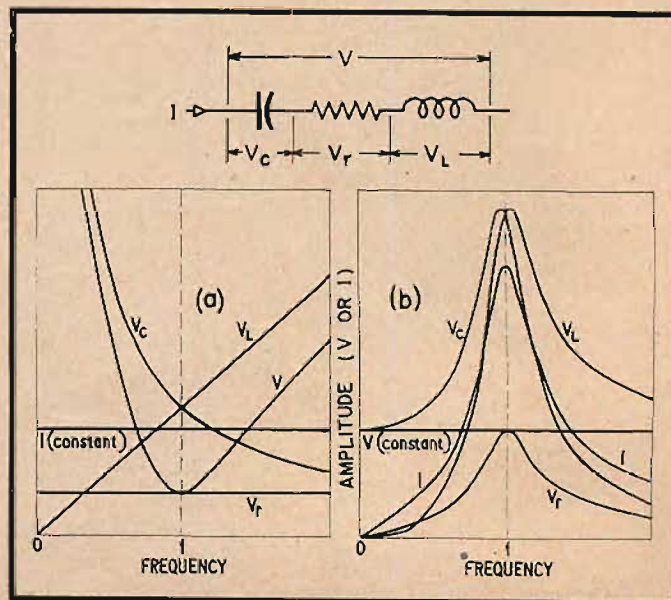

Fig. 2. Curves relevant to the resonance of a simple series circuit, using (a) constant current, and (b) constant applied voltage.



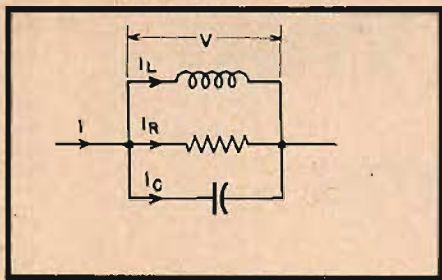

Fig. 3. This circuit is suggested as a better simple basis for consideration of parallel resonance.

condition, it follows they must each have a similar slope in the constant-voltage condition at resonance, where the current curve has a stationary point. So the peaks will be shifted by the influence of the slope shown in the constant-current curves.

**Parallel Resonance**

Now for parallel resonant circuits. Why not take the arrangement of Fig. 3 as basic? It has the advantage that consideration can take the same form as for the series circuit, of which it is actually the dual. In teaching, the term *duality* need not be mentioned at this stage, but the approach can well pave the way for introduction of this idea later. It is much easier to accept a principle if it can easily be identified with previous work. The curves of Fig. 2 can serve exactly by making the following substitutions:  $I$  (constant) and  $V$  (constant) are interchanged, as are also  $V$  and  $I$ ; and  $V_L$ ,  $V_C$  and  $V_R$  are replaced respectively by  $I_L$ ,  $I_C$  and  $I_R$ . It is convenient to distinguish between series and parallel components of resistance by the use of  $r$  and  $R$ , respectively, as symbols. This approach for parallel circuits has the advantage that impedance maximum occurs at the same frequency as zero phase or unity power factor.

Here the objection will be raised that such a circuit is not practical. But is it not as practical as the more conventional one? The only case where an inductor even approximates inductance in series with constant resistance is when an air-cored inductor is operated at relatively low frequencies. Inductors for low (power or audio) frequencies are more often iron-cored to increase their Q factor; and at radio frequencies, high-frequency resistance invalidates the assumption of constant resistance even in air-cored coils. There are cases where assumption of constant shunt resistance is a nearer approximation, over a range of frequencies at least, than assumption of constant series resistance. One such case is a gapped iron-cored inductor where the gap is smaller than that for optimum Q over the range considered. The principal loss is then core loss, and at the higher audio frequencies this will be principally due to eddy currents, which can be considered the result of a constant shunt resistance.

Another useful feature of this approach is that it can demonstrate the usefulness of the terms *susceptance*, *con-*

*ductance*, and *admittance*, as reciprocals of reactance, resistance, and impedance.

**Using The  $j$  Operator**

Now, what is wrong with introducing  $j$  at this stage? Possibly the student has not covered work in his mathematics introducing expressions such as  $\cos \theta + j \sin \theta$ . (Or do the mathematicians still prefer it?) But the author remembers at this stage of his own mathematical studies he wondered why *sine*  $\theta$  should have the imaginary coefficient rather than *cosine*  $\theta$ . For a long while it seemed quite arbitrary. Introduction of  $j$  with a practical purpose such as this in view will surely avoid such puzzled states of mind, although a rigorous proof for its use is not given, and the mathematics will be easier to absorb in due course. It can be shown that successive multiplication by  $j$  is equivalent to rotation of a vector through 90 degrees, and that the significance of "real" and "imaginary" as applied to in-phase and wattless components, respectively, is quite logical, without a rigorous mathematical proof. Conversion from combinations of conductance and susceptance to resistance and reactance and *vice versa* can be shown by inverting and rationalizing the denominator, and it will help the student to appreciate quickly the usefulness of  $j$ .

Figure 4 illustrates this for converting actual series components to equivalent shunt components. The actual series combination has an impedance of

$$Z = r + j\omega L \quad (1)$$

The corresponding admittance expression is

$$Y = \frac{1}{r + j\omega L} = \frac{r - j\omega L}{r^2 + \omega^2 L^2} \quad (2)$$

The admittance of the equivalent arrangement, using the resistance symbol rather than conductance, as the former is often more easily visualized, is

$$Y = \frac{1}{R'} + \frac{j}{\omega L'} = \frac{1}{R'} - \frac{j}{\omega L'} \quad (3)$$

For complete equivalence, the real and imaginary parts of expressions (2) and (3) must be equal, so the equivalent values are

$$L' = L + \frac{r^2}{\omega^2 L} \quad (4)$$

and

$$R' = r + \frac{\omega^2 L^2}{r} \quad (5)$$

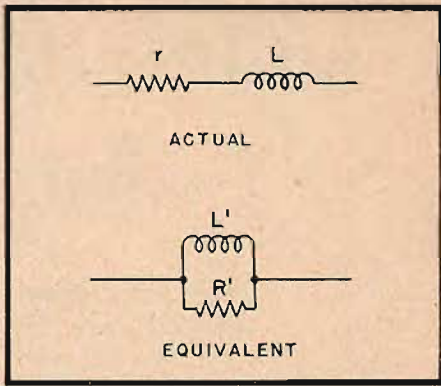

Fig. 4. Conversion of series elements into equivalent parallel connected elements.

Approximations for these expressions when  $r$  is small or large compared with the reactance  $\omega L$  can then be given:

$$r \ll \omega L: L' \approx L \quad (4a)$$

$$\text{and } R' \approx \frac{\omega^2 L^2}{r} \quad (5a)$$

$$r \gg \omega L: L' \approx \frac{r^2}{\omega^2 L} \quad (4b)$$

$$\text{and } R' \approx r \quad (5b)$$

Expressions (4a) and (5a) show that when  $r$  is small,  $L'$  is nearly the same as  $L$ , and  $R'$  varies in proportion to  $\omega^2$ . The equivalent inductance of (4b) has not much importance, but when the series inductive reactance is small the resistance value is nearly identical, whether the inductive component is considered as a small series inductance or a large shunt one.

Similar expressions for conversion the other way are:

$$L' = L \frac{R^2}{R^2 + \omega^2 L^2} \quad (6)$$

and

$$r' = R \frac{\omega^2 L^2}{R^2 + \omega^2 L^2} \quad (7)$$

$$R \gg \omega L: L' \approx L \quad (6a)$$

$$\text{and } r' \approx \frac{\omega^2 L^2}{R} \quad (7a)$$

$$R \ll \omega L: L' \approx \frac{R^2}{\omega^2 L} \quad (6b)$$

$$\text{and } r' \approx R \quad (7b)$$

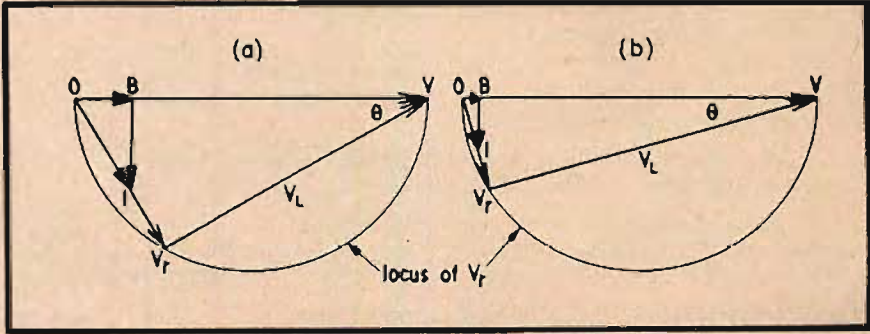

Fig. 5. Demonstration of expression (5a) by means of vector diagrams.

# Going, Going Going, West— for the Third Time

Audiofans, buyers, customers, doubting Thomases, engineers, fiddlers, general public, hucksters—all are entraining and enplaning and enautomobiling for the West's biggest audio event—Audio Fair-Los Angeles

**T**HE EVENING of February 10 will witness the largest collection of audio equipment ever assembled under one roof west of the Hudson River when the third annual Audio Fair—Los Angeles opens its doors to the public. Representatives of all leading equipment manufacturers will be present with their wares to delight the people of Southern California—and all others who find it easier to go to Los Angeles than to New York—for their audio enlightenment.

And the engineers will have their day too, with the coincidental West Coast Convention of the Audio Engineering Society, with sessions devoted to technical papers, meetings of section chairmen, planning, and just plain eating—for the first annual banquet of the Los Angeles Section is to be held on the evening of February 9.

As everyone knows who has ever attended an Audio Fair, it is likely to be a noisy affair—who would have it otherwise?—and thousands of people will go away with one idea firmly implanted in their minds, how do I go about building up a home music system for myself? All the answers will be at the show, for enough equipment will be exhibited to suit even the most critical enthusiast, and systems ranging all the way from \$150 to \$1500 could easily be put together from components selected at this gathering.

The following is a list of the exhibitors as of press time. As usual, others will sign up at the last moment, and those who attend will get more than they bargain for, since they can be sure at least of those listed here plus an almost certain few more.

ACOUSTICRAFT 48 E. San Jose, Burbank, California In Attendance: Charlie Klein	314	ANGEL RECORDS P. O. Box 201, Altadena, Calif. In Attendance: Ralph Auf Der Heide	686	D & R LIMITED 7225 Beverly Blvd., Los Angeles 36, Calif. In Attendance: Roland Olander	403
ALTEC LANSING CORPORATION 9356 Santa Monica Blvd., Beverly Hills, California 161 Sixth Ave., New York 13, N. Y. In Attendance: Ed Grigsby	409	ARCTURUS MANUFACTURING CORPORATION 4301 Lincoln Blvd., Venice, Calif. In Attendance: Paul Anderson	506	DAYSTROM ELECTRIC CORPORATION 753 Main St., Poughkeepsie, N. Y. In Attendance: Frank Randall	584
AMERICAN MICROPHONE CO. 370 S. Fair Oaks Ave., Pasadena 1, Calif. In Attendance: Gramer Yarbrough	657	AUDIO P. O. Box 629, Mineola, N. Y. In Attendance: C. G. McProud	543	ELECTROSONIC LABORATORIES P. O. Box 201, Altadena, California In Attendance: Ralph Auf Der Heide	686
AMPEX CORPORATION 934 Charter Street, Redwood City, Calif. In Attendance: Forrest Beard	521	AUDIO DEVICES, INC. 1006 Fairfax Ave., Los Angeles 46, Calif. In Attendance: Alan H. Bodge	459	ELECTRO-VOICE, INC. Cecil & Carroll Sts., Buchanan, Mich. In Attendance: Lawrence LeKashman	685
		AUDIO ENGINEERING SOCIETY P. O. Box 12, Old Chelsea Station, New York 11, N. Y. West Coast: Herb Farmer, University of Southern California, University Park, Los Angeles 7, Calif.	576	ESPEY MFG. CO., INC. 8346 Beverly Blvd., Los Angeles, Calif. In Attendance: Roy Smith	485
		AUDIO FAIR—LOS ANGELES	566	FAIRCHILD RECORDING EQUIPMENT CO. 154th St. & 7th Ave., Whitestone, L. I., N. Y. In Attendance: Jay H. Quinn	343
		AUDIOGERSH CORPORATION 1865 N. Western Ave., Los Angeles, Calif. In Attendance: Conrad Strassner	559	FENTON COMPANY 15 Moore St., New York 4, N. Y. In Attendance: Charles F. Fenton	540
		BELL SOUND SYSTEMS, INC. 555 Marion Road, Columbus 7, Ohio In Attendance: H. H. Seay, Jr.	679	FERRANTI ELECTRIC INC. 7225 Beverly Blvd., Los Angeles 36, Calif. In Attendance: Roland Olander	403
		DAVID BOGEN CO., INC. 29 Ninth Ave., New York 14, N. Y. In Attendance: Vinton K. Ulrich	512	FISHER RADIO CORPORATION 21-21 44th Drive, Long Island City 1, N. Y. In Attendance: James J. Parks	486, 487
		R. T. BOZAK CO. P. O. Box 201, Altadena, California In Attendance: Ralph Auf Der Heide	686	GENERAL ELECTRIC COMPANY Radio & Television Department, Electronics Park, Syracuse, N. Y. In Attendance: N. R. Bibko	684
		BRADLEY MFG. CO., INC. 11 W. Magnolia Blvd., Burbank, Calif. In Attendance: Frank Valenta	303	HARMAN-KARDON, INC. 520 Main St., Westbury, New York In Attendance: Sid H. Hecht	687
		BRITISH INDUSTRIES CORPORATION 164 Duane St., New York 13, N. Y. In Attendance: Leonard Carduner, Frank Hoffman	315, 318	HIGH FIDELITY MAGAZINE Great Barrington, Mass. In Attendance: Charles Fowler	440
		CALIFORNIA RECORD DISTRIBUTOR 2962 W. Pico Blvd., Los Angeles, Calif. In Attendance: Jack Lewerke	520	INTERNATIONAL ELECTRONICS CORPORATION 159 Howell St., Dallas, Texas In Attendance: Edmond A. May	418
		CAPITOL RECORDS DIST. CORP. 318 W. 15th St., Los Angeles, Calif. In Attendance: Robert C. Camp	405	JENSEN MANUFACTURING COMPANY 6601 S. Laramie Ave., Chicago 38, Ill. In Attendance: Louis W. Selsor	607, 608
		CONCERTONE 4917 W. Jefferson Blvd., Los Angeles, Calif. In Attendance: Bert Berlant, Ed Altschuler	609, 623	KARLSON ASSOCIATES, INC. 1483 Coney Island Ave., Brooklyn 30, N. Y. In Attendance: John Karlson	406
		CONRAC, INC. 19217 E. Foothill Blvd., Glendora, Calif. In Attendance: W. J. Moreland	515		

(Continued on page 46)

Introducing a new Triumph in engineering  
and designing skill created by **Pilot**

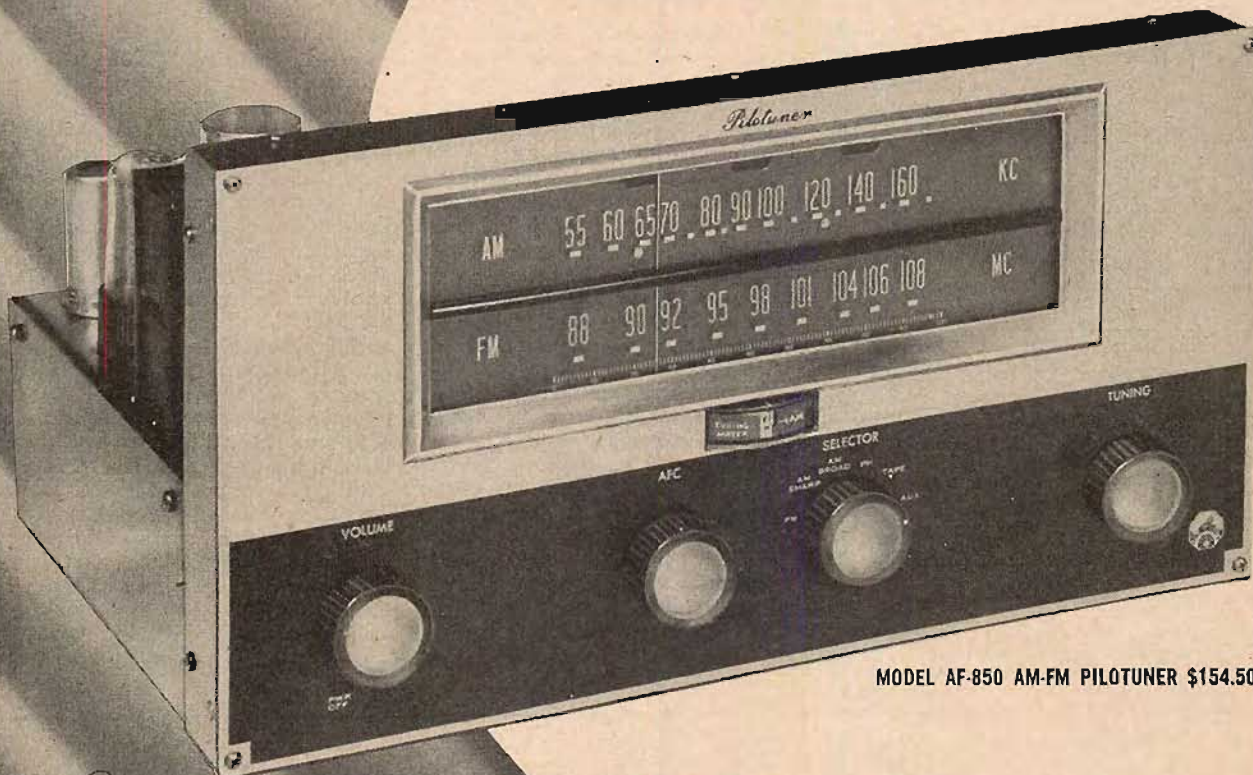

MODEL AF-850 AM-FM PILOTUNER \$154.50\*

the *Ultimate* in sensitivity interpreted by the exclusive

**micro-meter**



The *Ultimate* in High Fidelity . . . a proud achievement in engineering efficiency exemplified by Pilot's vast electronic experience for 35 years.

- Armstrong Dual Cascade Limiter—Discriminator circuit on FM.
- FM Sensitivity better than 1.5 microvolts for 20 db of quieting.
- AM Sensitivity better than 2 microvolts for 20 db signal-to-noise ratio.
- Exclusive **Micro-Meter** for Laboratory Precision Tuning on FM and AM.
- Continuously variable amplified AFC (automatic frequency control).
- Two-stage IF amplifier for broad or sharp AM bandwidth.
- Selectively illuminated slide rule dials.
- Temperature compensated oscillator for drift free operation.
- Cathode follower audio output permits use of up to 100 ft. of cable.
- Built-in power line antenna for FM. Built-in loop stick antenna for AM.

Visit your Pilot dealer for a new concept of brilliant musical reproduction. **\$154.50\***



Write for free brochure Dept. A-2

\*Slightly higher West of Rockies

**PILOT RADIO CORPORATION** 37-06 36th ST., LONG ISLAND CITY 1, N. Y.

# Equipment Report

Pilotone AA-420 Amplifier—Sargent-Raymont SR-808 Tuner-Tone Control—Radio Shack Corporation's Realist "af" Amplifier, Realist FM Tuner, Realist AM Tuner

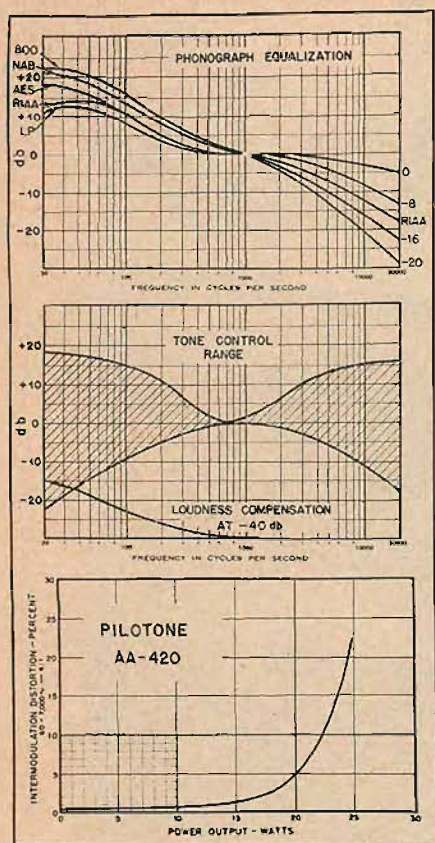

Fig. 1. Performance data on the Pilotone AA-420 Amplifier and Preamplifier.

**P**ILOT's new compact amplifier, the AA-420 is one which should make it possible for the music lover to set up a system in the smallest possible space with the assurance that his performance is not limited by the miniaturization of the equipment. This unit combines essentially the same facilities for phono equalization and tone control used on the AF-860 Pilotuner with a power amplifier having a 15-watt capability, and the over-all size is only 13 in. long, 10 in. deep, and 5 in. high. It uses seven tubes—a 12AX7 as phonograph pre-amplifier, a 6C4 and one half of a 12AU7 as voltage amplifiers, the second half of the 12AU7 as a phase splitter, two 5881's as output tubes, pentode connected, and a 5Y3GT rectifier. The construction is basically that of two separate units—the power amplifier which is similar to the AA-903, and a preamplifier section similar to that in the tuner, although on a small chassis. These two units are fitted together, and the entire assembly is enclosed in a perforated metal case which provides adequate ventilation. The schematic of the amplifier is

shown in Fig. 2, while the external and chassis appearances are shown in Figs. 3 and 4.

A study of the schematic will show some of the interesting features—among them being the provision of a level-set control on the three high-level inputs, RADIO, TAPE, and AUXILIARY, and the use of a dual volume control with one section ahead of the tone control stage and the other just ahead of the power amplifier section. This results in the minimum noise level, since the reduction of input signal to the power amplifier reduces hum arising in the tone-control section as the volume is lowered, whereas the first section of the control prevents overload of the input stage. As with most other Pilot equipment, the load resistor for the phono pickup is variable with a range from 6800 ohms to 100,000. This control and the level-setting controls are all located on a panel at the rear of the amplifier adjacent to the input jacks. In addition, a switch is provided to accommodate high- or low-level pickups, thus avoiding overload of the first preamp stage.

(Continued on page 62)

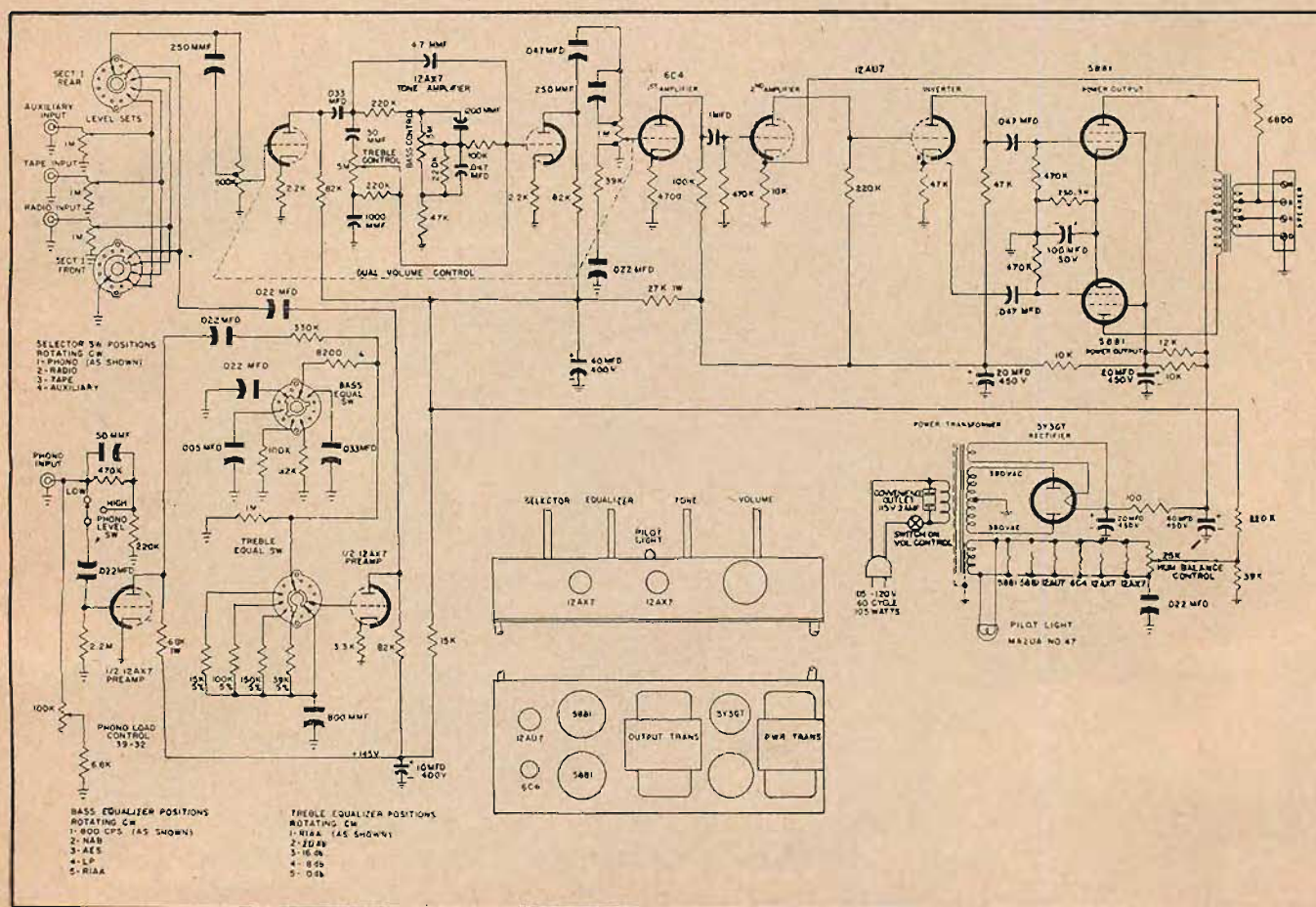
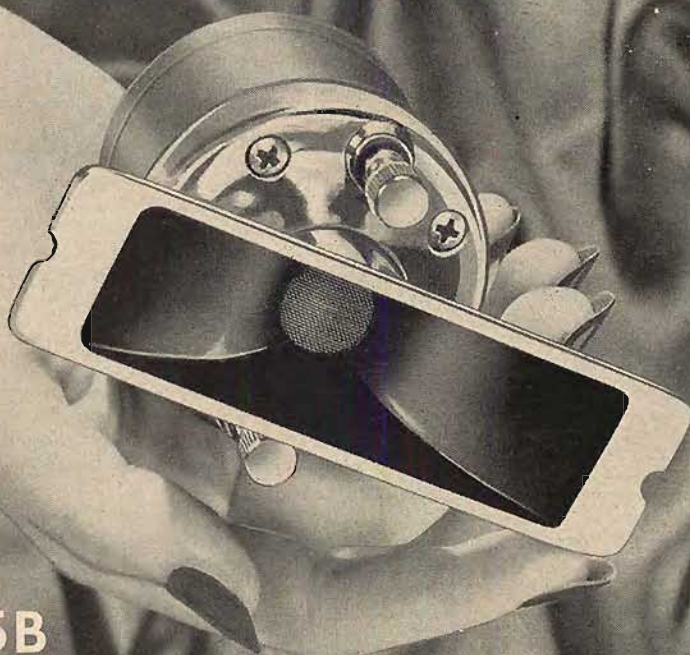

Fig. 2. Over-all schematic of the AA-420 amplifier.

# Silky Highs

IMPOSSIBLE TO OBTAIN WITH ANY OTHER TYPE SPEAKER  
3500 cps to beyond audibility / 180° Dispersion / + 56 db RETMA Rating



T35 and T35B

*Super Sonax*®

VERY HIGH FREQUENCY DRIVERS



The T35B—for lower powered systems and existing quality AM-FM radio or radio-phonographs, finished in flat matte black. Requires only X36 to attach to music system. AT37 level control optional. Impedance 16 ohms. Shipping wt. 2 lbs.



Beautiful Piccolino Accessory Enclosure for T35 or T35B, mahogany or blonde. List \$15.00, Audiophile net \$9.00.

The Piccolino, complete, Super-Sonax, X36 crossover and AT37 level control, wired to connect to music system: with T35 List \$90.00, Audiophile Net \$54.00; with T35B List \$70.00, Audiophile Net \$42.00.



Prove It To Yourself at Your E-V Distributor's—Test the T35 for yourself with this special demonstrator. You operate the switch that cuts the T35 in or out of an actual high fidelity system. Your ears give you the proof of T35 performance!

Any high fidelity music installation shows amazing improvement in the last two octaves with the addition of the easily installed T35 or T35B. The E-V T35 is without equal in its ability to reproduce highest audio frequencies with distortionless purity. At least one more octave of silky highs is afforded through use of T35 for systems over 20 watts, or T35B for systems under 20 watts. Solid 180° dispersion is accomplished by the E-V developed diffraction slit type horn. E-V Model X36 crossover and Model AT37 level control are designed for use with the T35 and T35B. Impedance 16 ohms. Shipping weight 2 lbs.

T35	List \$55.00	Audiophile Net \$33.00
T35B	List \$35.00	Audiophile Net \$21.00
X36	List \$14.00	Audiophile Net \$ 8.40
AT37	List \$ 6.00	Audiophile Net \$ 3.60

TODAY—write for Bulletin 194 and name of nearest E-V dealer.

**Electro-Voice**®

ELECTRO-VOICE, INC. • BUCHANAN, MICHIGAN

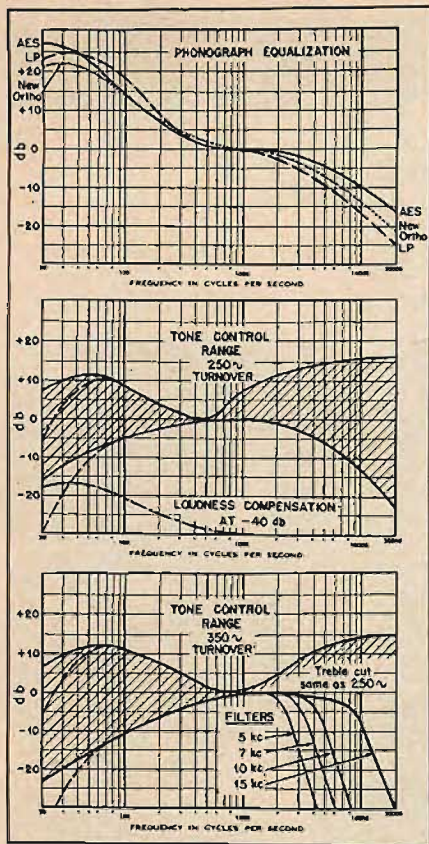

Fig. 1. Performance curves of the audio portion of the SR-808 Tuner and Tone Control.

## SARGENT-RAYMENT SR-808 TUNER and TONE CONTROL

Those who take pleasure in observing well constructed equipment in any form—amplifier, tuner, sports car, or watch—invariably study the design and its execution from every standpoint. Sargent-Rayment amplifiers and tuners have heretofore shown some excellent features, and this newest model is no exception. The line previously included an AM-FM tuner, an AM tuner, an amplifier-preamp unit, an amplifier, and a separate preamplifier-control unit.

The SR-808, introduced only a month or so ago, combines the AM-FM tuner with a preamplifier and tone-control section to provide everything except the power amplifier and speaker for a home system—unless one includes phono equipment as an essential, as most do.

The new unit, shown in Fig. 2, does offer considerable flexibility of control, and in addition provides some completely new features which have never before been incorporated in home equipment. The tuner itself is quite complete, with separate sections for AM and FM except for the tuning capacitor. The FM section consists of a grounded-grid input stage followed by a tuned r.f. amplifier and the mixer, with a separate tube being used for oscillator and a.f.c. control. The mixer is followed by two i.f. amplifier stages, two limiter stages, and a discriminator, using a total of nine tubes. The AM section consists of an r.f. amplifier stage, mixer-oscillator, one i.f. amplifier, and the Sargent-Rayment low-distortion detector. This consists of a diode rectifier feeding the grid of a cathode follower, with the latter deriving its bias

from the diode load resistance, and offering an a.c. load which is exactly equal to the d.c. load, an arrangement which eliminates most of the distortion which obtains on high-level modulation with ordinary diode detectors. A separate diode provides a.g.c. voltage, removing this load from the detector diode circuit. The tuning indicator is an "eye" tube which is permanently connected to the a.v.c. buses of both tuner sections, and the actuating signal derives from the section which is operating at any particular time—plate supply being switched to select the section in use. The selector switch also controls the heater voltages of the tuner sections, and when using the audio section for phono reproduction, both AM and FM heaters are turned off. As the user turns to either AM or FM, the heaters for that section are energized. We do not consider this a useful feature—as we explained to the manufacturer—but the reply was that many people feel that their tubes are being "worn out" unnecessarily if their heaters are energized even though the tubes are not in use. This may be true, but it would be no problem to wire this "feature" out, as we would do immediately since the delay in waiting for a section to heat up as we change from AM to FM, for example, or from phono to AM or FM, is a minor annoyance. For those who want to conserve tubes, this would be considered a useful feature; those who don't would simply jumper the switch, so it is not an important objection.

The audio section consists of a preamp tube with three phono curves, using feedback equalization, a two-section volume-loudness control, a five-position filter switch, and a cathode-follower output tube. The tone control section is located between two sections of the voltage amplifier tube, and feeds the compensated portion of the volume-loudness control. Provision is made to accommodate the usual magnetic pickups,

as well as the crystal, ceramic, and capacitance types, and a spare high-level input is provided for tape recorder, TV tuner, or whatever the user might require. Three outputs are provided—DETECTOR, which is ahead of the tone-control and filter circuits; TONE CONTROL, which includes these circuits; and MULTIPLEX-BINAURAL, which is a connection ahead of the de-emphasis network in the discriminator circuit of the FM section.

Figure 1 shows the performance curves for the SR-808 tuner and tone control. The top section shows the phono equalization curves with the filter out of circuit and with the tone controls flat, and the loudness control switched out. The center section shows the tone-control limits with the selector switch set at the 250-cps position. This requires some explanation, since this is one of the unique features of the tuner. As many listeners have observed, some types of tone controls give too great a boost in the upper low-frequency region as the control is advanced, so that the tone quality is "chesty" on male voices. However, this same type of tone control may be eminently satisfactory on music reproduction. Therefore, this tuner incorporates a switch along with the continuously variable bass tone control to offer a choice between two inflection points. In addition, either inflection point—250 or 350 cps—may be selected with or without a 50-cps cut, which may be used to eliminate hum from a radio program, for example, or to reduce rumble from a faulty turntable. Thus the curves in the center section of Fig. 1 shows the limits of tone-control action with the 250-cps turnover, the dotted lines at the left showing the effect with the 50-cps cut in operation. Also shown in this section of the performance curves is the effect of the loudness compensation with the volume reduced 40 db from the maximum position

(Continued on page 63)

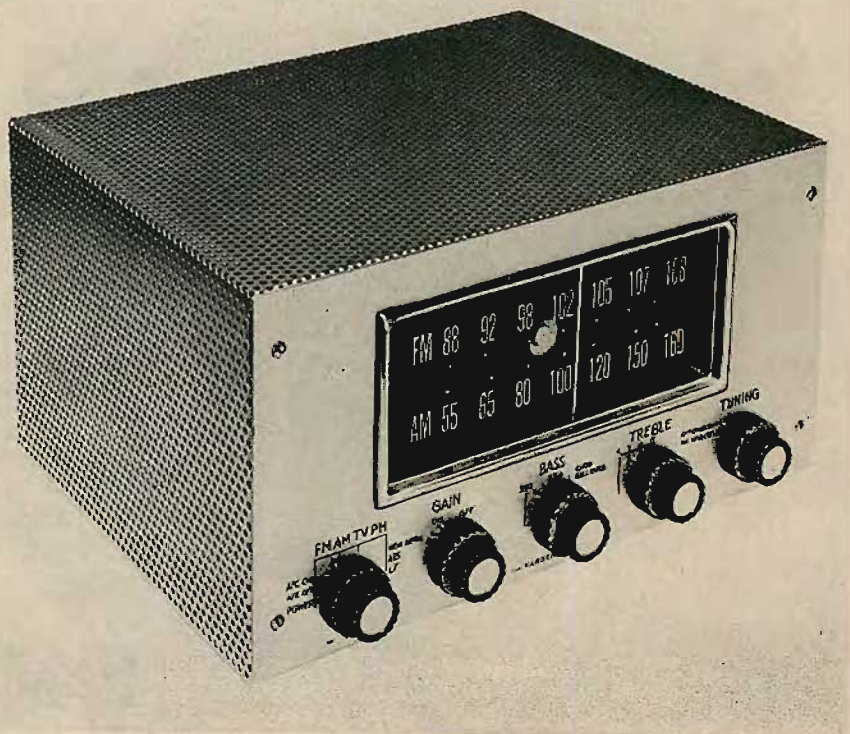

Fig. 2. Sargent-Rayment model SR-808 tuner and control unit.

# NEW...G-E 3-WAY RECORD FILTER

## Filters all noise... restores balance to every record... Only \$19.95\*

HERE is a brand new concept in filter systems. Every accessory control for fine music reproduction is wrapped up in this one instrument. There's a Lo cut-off to suppress turntable rumble and vibration... a Hi cut-off for total reduction of record scratch and high frequency distortion... plus a complete compensator selection.

Now—compare the cost. General Electric's Record Filter is priced at little more than half what you'd pay for less flexible instruments! It belongs in every type of home record equipment. Hear it soon and treat yourself to the custom-tailored brilliance this filter reveals... with even the oldest recording in your collection.

*\*Subject to change without notice. Slightly higher West and South.*



FOR CUSTOM INSTALLATIONS...

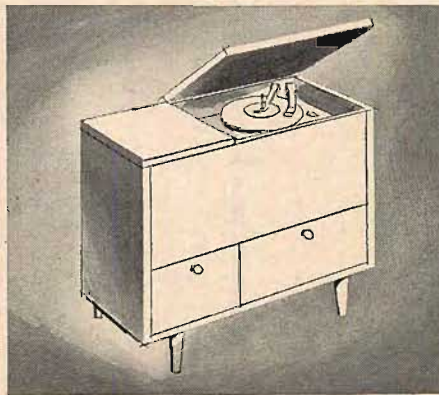

OR CONSOLE PHONOGRAPHS...

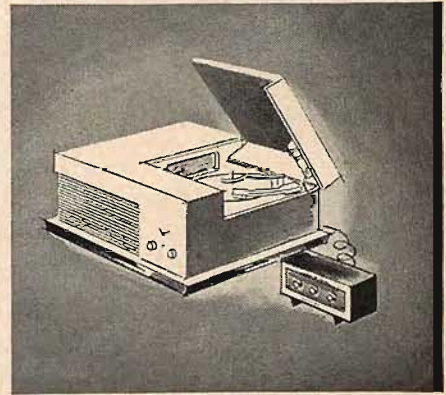

EVEN WITH INEXPENSIVE RECORD PLAYERS

- Lo cut-off—Four positions 0, 40, 60 and 80 cps.
- Hi cut-off—Four positions 3, 5, 9kc and flat.
- Six Selective Compensator settings.
- Completely independent controls.
- Developed exclusively for use with G-E variable reluctance cartridges or similar types.
- Use with or without compact cabinet.

**BE THE FIRST TO OWN ONE!  
MAIL THIS COUPON TODAY!**

General Electric Company  
Radio & TV Department, Section R4425  
Electronics Park, Syracuse, N. Y.  
Please send me information regarding your  
new 3-Way Record Filter.

NAME .....

ADDRESS .....

CITY..... STATE.....

*Progress Is Our Most Important Product*

**GENERAL  ELECTRIC**

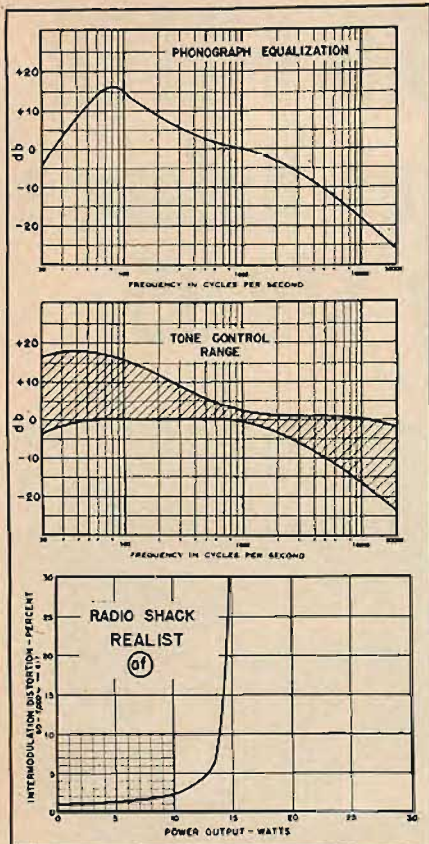

Fig. 1. Performance curves for the Realist model AF amplifier.

## “REALIST” COMPONENTS CORPORATION’S RADIO SHACK

When space considerations enter into the selection of equipment for a modern home music system, the user is confronted with a problem—“Shall I forego a radio tuner, or must I provide the space for one even though it means that I may have to cut down on some other component in order to get the tuner into the available space?”

The new “Realist” tuners—both AM and FM—are extremely compact, and if the addition of the tuner or tuners makes it necessary to cut down on the space for the amplifier—then the Realist amplifier can help, because it, too, is quite compact. And it appears that the compactness have been achieved without too much corner-cutting, for the performance measures up fairly well with many of the other small amplifiers on the market. One of the principal advantages of the Realist tuners is that they make it possible to add an FM tuner to a present installation with a minimum of expense—or to add the AM tuner when a larger and more elaborate FM unit is already in use but where the owner finds it desirable to have AM to get some of the stations that are not duplicated or possibly to add the facility for stereophonic reception.

### The Amplifier

The AF model Realist amplifier consists of four stages—a 6SC7 as the preamp with feedback-type equalization and with a switch which makes the stage “flat” for microphone input; a 6SL7 serving as a

voltage amplifier and self-balancing paraphase splitter which drive a pair of 6V6’s connected as pentodes. The output transformer offers impedances of 4, 8, and 16 ohms, and feedback extends back to the cathode of the first section of the 6SL7.

The unit also provides for an input from a crystal pickup or a radio tuner, and a jack for output to a tape recorder—the latter being connected ahead of the volume control. A 5V3GT rectifier furnishes plate current for the unit, using a total of 90  $\mu$ f of filter and decoupling capacitors.

The volume control is compensated, with the bass tone control acting to remove the compensation as desired. The treble tone control serves only to reduce high-frequency response. This would be adequate for the average installation, although some users might feel the need for bass boost over that which is provided, and might want it to be separate from the volume control compensation. In addition, some users might feel the need for some degree of bass cut. It is rare that treble boost is used for consistent listening, and it is not unusual that the amplifier does not provide the treble boost that some find occasionally necessary. In view of the low cost of this amplifier, however, it is felt that these refinements may well be dispensed with, and that satisfactory performance can be obtained without them.

The performance curves of the amplifier are shown in Fig. 1. Intermodulation distortion just barely exceeds 2 per cent at 10 watts output, and from 5 watts down remains below 1.5 per cent, which is about normal for 6V6 amplifiers. Equalization at the low end for phonograph is approximately correct for the RIAA curve, with slightly more rolloff than normal on the high end. With the volume control set at 40 db below maximum—which would be about right for average listening levels—the compensation at 50 cps is of the order of 15 db, and this may be reduced by operation of the bass control at the discretion of the user.

At maximum setting of the volume control, an input signal of 0.26 volts gives a 1 watt output from the radio input jack, while a 2.5 mv signal from phono or a 3.2 mv signal from a microphone will give the same output. Power consumption is 65



Fig. 2. External appearance of the Realist amplifier.

watts. Figure 2 shows the external appearance of the amplifier.

### The FM Tuner

The Realist FM Tuner is an intriguing little device, for in spite of its small size and low cost, it is sensitive and capable of putting out a high-fidelity signal. The entire chassis is only  $4\frac{1}{4}$  in. high,  $9\frac{1}{2}$  in. long, and  $6\frac{3}{8}$  in. deep, and can either be mounted in an opening  $3\frac{7}{8}$  by 9 in. or used in a wooden cabinet which may be obtained for use with it. It has its own power supply, and is equipped with a power switch and a tuning control, in addition to a phono-radio switch on the front panel which permits the installation to be made with an existing amplifier which accommodates “phono” inputs—making it especially convenient for use with existing radio sets, for example, or as an accessory for use with a TV set which is equipped with a phono jack. Thus the pickup lead is simply removed from the other radio or TV set and the lead from the tuner is plugged in instead—the phono lead then being plugged into the FM tuner chassis. Power consumption is 26 watts under no-signal conditions. The chassis is shown in Fig. 4.

The circuit of the tuner is conventional, as shown in Fig. 3. It employs a tuned r.f. stage using the pentode section of a 6U8, followed by the triode section serving as the mixer. The oscillator and the a.f.c. reactance tube employ two halves of a 12AT7, and two 6AU6’s are used as i.f. amplifiers. A third 6AU6 serves as a

(Continued on page 64)

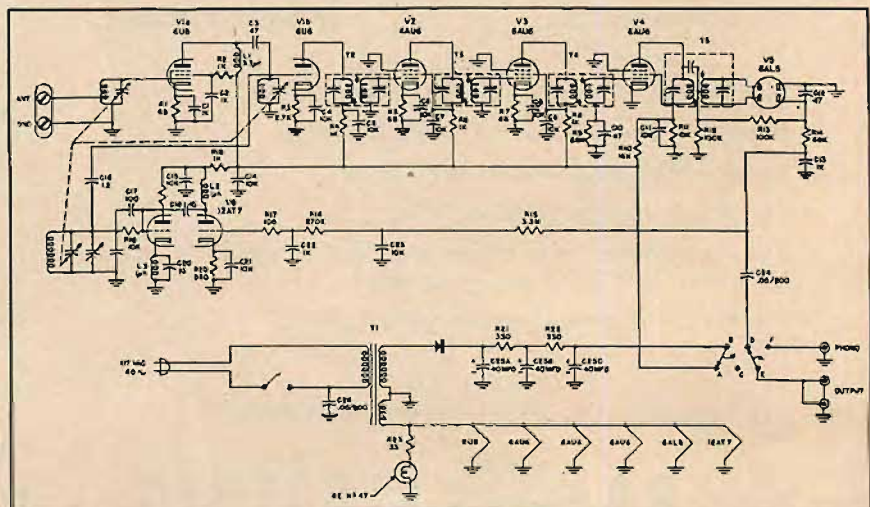

Fig. 3. Schematic of the Realist FM tuner.





## EDWARD TATNALL CANBY\*

### Big Noise

**T**HIS MONTH'S recommended Big Noise, you'll be surprised to hear, is on a low-cost label, Columbia's Entré. (They pronounce it AWNTRAY, far as I know.) The set has two LP records, but the lower price will help you decide that you can afford it—after you've heard the last part of Side 1. . . .

**Berlioz: Requiem Mass. Chorus, Orch. Rochester Oratorio Soc., Theodore Hollenbach; Ray De Voll, tenor.**

**Columbia Entré EL-53 (2)**

Berlioz is becoming a well known, if somewhat eccentric, hi-fi composer, not to be trusted too far (he's apt to go off into a half hour of pianissimo music between two good "demonstration" passages—most inefficient of him) but at his best unbeatable, because of (a) superb orchestration, like nobody else's, and (b) sheer enormousness of effect, with huge orchestras, organs, brass bands, choirs, etc.

Band Two, side One, of this work, will outlive every other hi-fi record ever made except another of this same piece, and the sound of its music will never be rivalled elsewhere by any conceivable change. Why?

This is the famous Dies Irae with its second part, the Tuba Mirum (the trumpet of doom) that, beginning with vast masses of singers, 250 here, includes not only a huge orchestra but four brass bands that are supposed to be situated at the four corners of the earth—pardon me, of the church, cathedral, concert hall, colosseum or what have you, plus the most enormous battery of kettle drums ever known to man, all pounding away at once. What an incredible sound! I've been in the midst of a relatively stripped-down performance of this music—we didn't have enough drums nor brass—and I never hope to hear such an astonishing noise again in my life; this performance purports to have the full instrumental complement, and it sounds that way.

How loud? Loudness isn't the point, on records. There is, of course, a maximum level that can be cut into a standard record and this one does not exceed it, nor should. The loudness is a function of your equipment. But here, at last, is a recording that you may play as loud as you want—and yet not exceed the intended ear volume and ear-effect—for I am dead sure that if Berlioz could have doubled the hitting power of his music he would instantly have jumped at the chance! Here's a chance of a lifetime, for those who are always getting sat on because they play hi-fi music too loud for the composer's intentions.

I've long since learned to play most of my music at a reasonably medium-power volume, about half what my equipment will do. When this Turba Mirum arrived, I shoved 'er into high gear and opened up. Wow! My ears were ringing afterwards, but I played it right over again. Here is the ultimate coming-together of music and hi-fi power.

It isn't so much the sheer noise, either, but the extraordinary quality of that noise—the skillful orchestration, on a colossal scale. First—have you any idea what X kettledrums (the number is finite, but I won't spoil your anticipation) sound like, all going together full blast? It is a sound like an approaching avalanche, or of fifty fast freights a mile away, or a devastating earthquake in the neighborhood. It will remind you of a vast mountain thunderstorm where the thunder never ceases but blends into a continuous roar. And over this extraordinary noise—what sound, you'll ask, could cut through it—comes the successive blasts of the great brass bands in their four corners; no other musical instruments could brave those vast drums. And on top of it all, an almost inaudible yell of doom, comes the combined singing, in high octaves (chords would never get through to be heard) of the 250 pipsqueak voices against the continuous thunder. . . .

Try it for yourself. There's a vast quantity of other music here too, for those who tire of kettledrums. (Some other "hi-fi" passages as well, of a less earthquake-like power.) The performance is an odd one, wonderfully enthusiastic on the part of the mainly amateur singers, strongly felt in just the direct, naive, dramatic, uncritical way that Berlioz intended, except that in the pure technical details, of phrasing, dynamics, tone production, there is a stiffness, an unsubtlety, that is decidedly not Berlioz. The spirit could not be improved; but the actual music could be better shaped, more poetic, more romantic. Berlioz was naive, but he was no musical amateur. Loud or soft, his music like most French music must be turned out with a finesse, that here is lacking.

**Ravel: Pavane pour une Infante Defunte; Le Tombeau de Couperin; Bolero. French Nat. Radio Orch., Cluytens. Angel 35102**

Everybody knows the famous cumulative build-up of sound in Ravel's "Bolero", a "natural" for the big hi-fi machine. Well, there's an extra wallop, perhaps unintentional, in this recording, which adds considerably to the potency of this particular Big Noise.

Don't start with the "Bolero"; put on the other side and play it all the way through, first. The dark-toned "Pavane", one of those richly antiqued works of Ravel, dignified, stiffly graceful, modern-mediaeval, makes a superb beginning and, as I hear it, this performance seems deliberately toned on the reserved side, the colors kept dark brown, rich, but keyed low. The wonderful "Tombeau", a miniature suite of a less formal antique sound, lightens considerably when it appears; but still in comparison to other playings it is here somewhat veiled, richly veiled. The mood picks up, bright colors appear everywhere, lush melodies, chiseled harmonies, warmth—but, you will feel, there is still something to come.

The end of this record-side left me a bit disappointed. I had expected more of an opening-foreshadow, more of a giving. But then I turned the record over, for the "Bolero". ("Might as well listen to the d-d thing once. . .")

Maybe it's my own imagination, but I would swear that the famous "Bolero" starts off right out of the preceding two works, picking up the

still somewhat reserved mood, carrying it right on into those ominous early repetitions of the famous two-section theme. Still on the cold side—but what an awakening is to come!

I leave the rest to you. I can only say that the old "Bolero" never mounted such an appallingly terrifying climax in any performance I've ever heard before, as it came forth in this particular sequence of events. (And I heard it brand new and "live" with the Boston Symphony the very year it was composed, 1928.)

I don't have it with me, but the Paul Paray "Bolero," of recent Mercury vintage, would seem to me to be an interesting one to compare with this—for that estimable comic conductor did a tour de force with the "Bolero," turning it into a quite believable good humored dance, utterly musical but not at all appalling!

**Echoes of Hi-Fi Vox. (15 Excerpts). Notes by R. D. Darrell. Vox UHF-1 (10")**

There seems to be a slight confusion here as to the intention of this disc; Vox itself suggests that you shop in your home, browsing through the Vox catalogue in terms of actual sound, whereas Mr. Darrell assumes that you will buy the disc with one thing in mind—hi-fi demonstration. Both are quite feasible.

I'll say honestly that I played just enough of this to get the hang of it—which is loud, louder, and louder still. I have an awful hankering for soft music these days and this merely whets my appetite. But let's be objective—and you choose for yourself.

The record has excerpts from the Vox catalogue, many of them necessarily incomplete sections of music. The breaks are relatively well done—no ghastly fades in the middle of a musical sentence. But musically they still hurt, like the finale of the Beethoven 8th which ends suddenly, high and dry, on a sub-dominant (IV) cadence, just crying for the few short measures that remain to the end of the piece. Nevertheless, of its type this is a good editing job. Good, if you accept the principle of excerpting, which I never shall.

Good: the shortest, quickest frequency run I've heard—a pleasure after those long, solemn processions of pure tone, "THUREE thousandddd, beeeeeeeeeeeeeeeeeeeeeeeeeeep." This one goes so fast you'll gasp, but it gets all the way down, from 15K to 20 cps.

Bad: Vox sticks to the more extreme pre-emphasis of highs characteristic of the older NAB and LP curves and this is accentuated by the prevailing close-up Vox recording technique (in a big liveness, always). It seems to me that for hi-fi loud sounds such as these Vox is making a mistake; the pre-emphasis should be reduced, in line with the newer curves, for less distortion in the playing.

I'm not suggesting that there is distortion on the record. There may be very little. But isn't that academic, for any record that is subject even to average hi-fi equipment? On most people's equipment, right up into the fancy brackets, these excerpts will come through with some very ugly sounds in the higher areas, due to the extreme stresses in these regions produced by the heavily boosted high highs. With less high boost, that stress would be less; the sound, for most of us, much cleaner.

\* 780 Greenwich St., New York 14, N.Y.

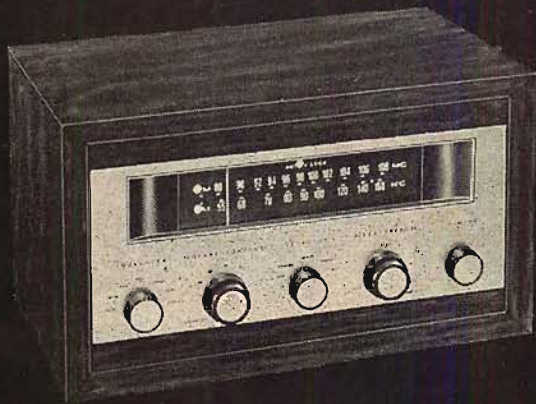

## Portrait of a homing pigeon

### NEW BOGEN AUTO-LOCK TUNER "ZEROS IN" FROM FRINGE TO PERFECTION

Your "knob jockeying" days are over. With the Bogen R765 FM-AM Tuner you just tune until you hear the FM station you want—and let go! Before you can sit back in your favorite chair, Auto-Lock tuning takes over to make precise adjustments for unbeatable reception . . . and then locks into position.

No chance for drift. No chance for a strong signal to dominate the AFC. The AFC will not operate until you have selected the station. An instant later a light on the panel indicates that the AFC is on and you are locked into precise tuning.

#### R765 TUNER FEATURES:

- Extreme Sensitivity
- Complete silence between stations on FM
- Precision record equalization (7 positions)
- Feedback tone controls
- Delayed AFC (Auto-Lock) for simplified FM tuning
- Colored dots on controls indicate best settings for your neophyte Aunt Minnie

R765 Tuner in chassis form—\$199.50.

R765W Tuner in handsome blond or mahogany veneer cabinet—\$221.75

Write for specifications on the perfect companion amplifier, Bogen D030A with exclusive "ultimate damping."



**Bogen**  
HIGH FIDELITY  
BECAUSE IT SOUNDS BETTER

David Bogen Co., Inc. Dept. VB  
29 Ninth Avenue, New York 14, N. Y.

Please send me your 56 page book, "Understanding High Fidelity," by L. H. Bogen and Louis Biancolli. This new enlarged edition presents invaluable practical information to help get more out of any sound system. I enclose 25¢ for my copy. Also send catalog.

Name \_\_\_\_\_

Address \_\_\_\_\_

City \_\_\_\_\_ Zone \_\_\_\_\_ State \_\_\_\_\_

Send free catalog only.

Send this coupon today!



*Build it  
YOURSELF*

**Heathkit  
HIGH FIDELITY  
PREAMPLIFIER**



MODEL WA-P2

performance and most attractive in appearance. Fulfills every requirement for true high fidelity performance. Shpg. Wt. 7 lbs. **\$19.75**

**Heathkit**

**WILLIAMSON TYPE  
(PEERLESS TRANSFORMER)**

This latest and most advanced Heathkit hi-fi amplifier has all the extras so important to the super-critical listener. Featuring KT-66 tubes, special Peerless output transformer, and new circuit design, it offers brilliant performance by any standard.

Bass response is extended more than a full octave below other Heathkit Williamson circuits, along with higher power output, reduced intermodulation and harmonic distortion, better phase shift characteristics and extended high frequency response. A new type balancing circuit makes balancing easier, and at the same time permits a closer "dynamic" balance between tubes.

Aside from these outstanding engineering features, the W-5 manifests new physical design as well. A protective cover fits over all above-chassis components, forming a most attractive assembly—suitable for mounting in or out of a cabinet. All connectors are brought out to the front chassis apron for convenience of connection.

Model W-5M consists of main amplifier and power supply on single chassis with protective cover. Shpg. Wt. 31 lbs. **\$59.75**

Express only. Model W-5 consists of W-5M, plus WA-P2 Preamplifier shown on this page. Shpg. Wt. 38 lbs. **\$79.50**

Express only

**Heathkit**

**HIGH FIDELITY  
20 WATT AMPLIFIER**

This particular 20 watt Amplifier combines high fidelity with economy. Single chassis construction provides preamplifier, main amplifier and power supply function. True hi-fi performance  $\pm 1$  db, 20 eps to 20,000 cps. Preamplifier affords 4 switch-selected compensated inputs. Push-pull 61.6 tubes used for surprisingly clean output signal with excellent response characteristics and adequate power reserve. Full tone control action. Extremely low cost for real high fidelity performance. Shpg. Wt. 13 lbs. **\$35.50**



MODEL A-98

**HEATHKIT**  
*High Fidelity*  
"BUILD IT YOURSELF"  
**amplifier  
kits**

**Heathkit**

**WILLIAMSON TYPE  
(ACROSOUND  
TRANSFORMER)**

This dual-chassis high fidelity amplifier kit provides installation flexibility. It features the Acrosound "ultra-linear" output transformer, and has a frequency response within 1 db from 10 eps to 100,000 cps. Harmonic distortion and intermodulation distortion are less than .5% at 5 watts, and maximum power output is well over 20 watts. A truly outstanding performer. W-3M consists of main amplifier and power supply. Shpg. Wt. 29 lbs., Express **\$49.75**  
Model W-3 consists of W-3M plus WA-P2 Preamplifier listed on this page. Shpg. Wt. 37 lbs., Express **\$69.50**



**Heathkit**

**WILLIAMSON TYPE  
(CHICAGO TRANSFORMER)**

This hi-fi amplifier is constructed on a single chassis, thereby affecting a reduction in cost. Uses new Chicago high fidelity output transformer and provides the same high performance as Model W-3 listed above. An unbeatable dollar value. The lowest price ever quoted for a complete Williamson Type Amplifier circuit. Model W-4M consists of main amplifier and power supply on single chassis. Shpg. Wt. 23 lbs., Express **\$39.75**  
Model W-4 consists of W-4M plus WA-P2 Preamplifier. Shpg. Wt. 35 lbs., Express only. **\$59.50**



COMBINATION  
W-5M and WA-P2



**BENTON HARBOR 25,  
MICHIGAN**

Why boost highs so greatly? The old necessity for noise reduction is now an outdated excuse, for there is no longer any very good excuse for noisy plastic, considering the high quality of a lot of it. As standards for plastic have gone up, boosted highs have come down. Witness the newer Angels that, as far as I can figure, have considerably less high boost than the new curves over here demand—not far from none at all. They sound wonderful, and the plastic is good enough so that noise is still decidedly low, even when the playing is flat in the highs, without roll-off. This is a highly desirable end in respect to true hi-fi. How about it, Vox?

**Haydn: Symphonies #100 ("Military"), #102. London Philharmonic, Solti. London LL 1043**

Well, well! Welcome back to our columns, London—just received the first ffrs since around April '54. Dunt ask why—we like 'em around here. Anyhow, this one is a pleasure on several counts.

First, after all that time it is good to hear the old reliable ffr sound, just as it always was, in a world of sound where somebody thinks up a new extreme every day.

Londons, and I'll have to hand it to them, were the first records we had over here (originally on 78's, before LP) to use the newer techniques of "trick" microphoning—trick only in the sense, so often discussed here, that recording technique must be contrived, for the special effects of sound reproduction in the home. (Even a one-mike pickup is contrived, for the mike is usually hung up where no "live" listener would hang, fifteen feet or so directly above the conductor of the orchestra.)

When it first appeared, ffr seemed to our ears pretty extreme; the strings seemed sharp and close, the solo instruments often enlarged, magnified. But I think that was inevitable; for it takes all of us awhile to learn that wide-range music via the phonograph has its own laws and its own sound, quite unlike that of the concert hall. As long as we used the old tin boxes, or the mammoth boom-chambers, the details of sound were academic; but when hi-fi came along (and it was not last year either) we began to listen for the actual concert hall—and of course we did not find it.

But now our ears have learned to evaluate recorded sound in its own terms. London's ffr, though not always ideal for every combination of music and instruments, was surely, as we now can hear, a reasonable and sensible approach, with moderation, to the "new sounds" now being so widely exploited under the banner of hi-fi. The strings still glitter, close-up, the triangle is still larger-than-life; but not too large. It has to be larger than life, for best recorded effect.

To get to cases—compare this Haydn "Military" Symphony with the ever-famous early Westminster version that shook the Audio Fairs three or four years ago. That was one of Westminster's first hi-fi sensations and one of the first of the new extreme recordings. The cymbals were perfectly enormous, in the famous slow movement military (Turkish music) section, and the big bass drum practically blew you out of your chair at each thump.

A deservedly sensational release—but this one, from London, is far nearer to a musical realization of those same sounds via the recorded medium. The cymbal is still bigger than life, but only a bit so; the drum is still huge, but not too huge. The triangle sounds only moderately telephone-like.

And—for the rest of the music—the sound is beautifully round, in excellent perspective, live, but not with that enormous, exaggerated liveliness of the extreme hi-fi discs.

In other words, radical ffr has now, with the force of time, become respectably conservative ffr, and I'm all for it.

Note, musically, that Solti's big-sized Haydn is in the excellent new tradition that treats the late symphonies as big, near-Romantic works rather than "cute" little tid-bits full of clever wig-jiggling. Scherchen's best work for Westminster was in this area; Solti's Haydn is less dramatic, more comfortable, but not a tiny bit cute, nor are his tempi exaggerated either too fast or too slow. The superb #102—also one of Scherchen's best—is memorable here.

*Write* **FOR FREE CATALOG AND SCHEMATICS**

## BEETHOVEN AND SCHUBERT

**Schubert: Symphonies #1, #2.** Royal Philharmonic, Beecham. Columbia ML 4903

Those who have thought Schubert's "Unfinished" the beginning and end of Schubert symphonic listening would do well to try a few of the six early symphonies—works admittedly not quite in the "great" category but nonetheless clearly the music of a sheer genius at musical communication, and a joy to listen to.

Symphony Number One was composed by Schubert at 16. To the expert—very expert—ear there are certain relatively unperfected aspects to it, redundancies, sequences, somewhat overblown construction. But how utterly unimportant is this alongside the startling evidences of extraordinary musical powers! For this is the purest Schubert, even at 16; it is full of typical Schubert devices of later years, harmonies, ways of orchestrating, above all that superb sense of lyric melody that joins all the parts together so flawlessly and with such grace. A piece of music to bow down before in humility, that it exists as a remembrance of an astonishing youth.

Perhaps the most significant "lesson" to be heard in this work is the insight it gives us into the state of musical training of a gifted young Viennese music student at the tender age of 16, back in the early 1800's. Schubert had just left the Imperial Konvikt, a choir school where the boarders studied music and practiced it along with a general education. (The present Vienna Choir Boys are the descendants of this organization.) An extraordinary amount of music-making was accomplished. The student orchestra—children from 16 down, remember—played through at least a symphony and an overture every evening, the students composed right and left for whatever medium was available. In addition, there was much home music-making in the Schubert family.

Schubert's First Symphony was written for this orchestra of kids shortly after (his voice having changed) he "graduated;" it reflects directly the musical ideas and the techniques of composition he had been absorbing through all this intensive musical experience. How many of our own little geniuses get a tenth as good a musical background?

Sir Thomas Beecham has a special fondness for early Schubert and gives these the very best of his own sure lyric powers with an orchestra, without a trace of the eccentricity that he often indulges in when more famous works are involved. He treats both of these as though they were entirely mature symphonies, and it is amazing how much of their substance really blossoms out under the treatment. A highly recommended disc.

**Schubert: Piano Sonatas in D, op. 53, E Flat, op. 122.** Friedrich Wuehrer.

Vox PL 8820

Another disc in the series by this pianist that is to cover the entire list of Schubert sonatas, some of the most difficult works, musically, in the entire piano repertory. I missed the second disc (this is the third), but my impression that Herr Wuehrer is a master pianist but a hard-fingered one is strengthened by this record. Definitely, this man is a big artist. (He teaches master classes for selected advanced student pianists at Salzburg.) But, within that category, I'd suggest that he is among the less lyric Schubert interpreters, stressing the violent, hard, explosive music that is undeniably in Schubert, playing the priceless lyric parts with a certain grimness (a driving, rather staccato touch) that isn't always ideal.

Possibly the hard piano tone is due in part to rather close-style microphone placement; one cannot be entirely sure. But my hunch is that the music would be hard in the flesh as well. Fingers of steel.

The D major sonata with the lower opus number is actually a later work, published during Schubert's lifetime, one of those huge, rambling, all-powerful monsters that almost defy the performer's attempt to unify them for the ear. Wuehrer's driving power does the job in one way; another is to stress the superb lyric melodies and the striking harmonic contrasts, letting continuity take care of itself. That, to my mind, is what Schubert meant. His large architecture is usually made up of many a smaller drama, cumulatively, not unlike the Wagnerian technique of later times.

The E Flat, opus 122, is an early sonata, much simpler and more easily tuneful, not nearly as difficult in the performing. (It was published after his death—hence the higher opus number, as with most early Schubert works.)

*The Sensation of Two Audio Fairs . . .*

# PERMOFLUX

*Largo and Diminutive*  
2-WAY SPEAKER SYSTEMS

Now Available Under

HTP\*

Acclaimed at the Sight and Sound Exposition in Chicago and the Auditorama in New York, these amazing high-fidelity speaker systems are now available under HTP—an exclusive Permoflux insured plan that enables you to try a Largo or Diminutive in the quiet and comfort of your own home for 15 days. See your hi-fi dealer today!

\*EXCLUSIVE PERMOFLUX 15-DAY INSURED HOME TRIAL PLAN, INTRODUCED AT THE CHICAGO AND NEW YORK AUDIO FAIRS, OCT., 1954

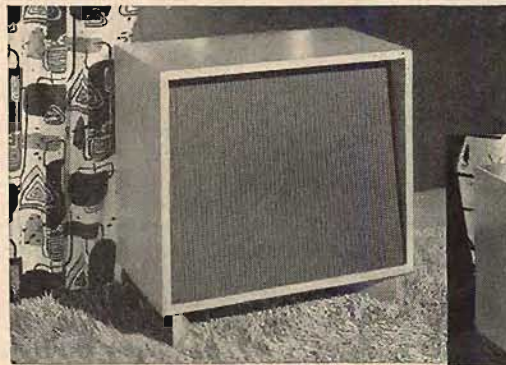

### THE LARGO

Outstanding wide-range speaker system at moderate cost. Uses the "Super Royal Eight" speaker and Super Tweeter. Unique new-type back-loading horn enclosure is matched, octave by octave, to speakers . . . assuring undistorted reproduction from 35-16,000 cps. In selected ¾" Mahogany or Korina veneers. Exclusive: Special connection for headset extension cord. Size: 24" W, 23" H, 14" D. Impedance, 8 ohms.

Suggested Audiophile Net . . . \$99.75

### THE DIMINUTIVE

A marvel of compactness featuring "big-system" reproduction over the full audio range and low cost. Ideal for use in a bookcase or as extension speaker. With 2 "Royal 6" speakers and Super Tweeter. In Mahogany or Blonde finish ¾" veneers. Size 23½" W, 11½" H, 12" D. Impedance, 4-8 ohms.

Suggested Audiophile Net . . . \$49.50

As above, but with selected ¾" Mahogany or Korina veneers.

Suggested Audiophile Net . . . \$64.50

HEARING IS BELIEVING! Try either system at home under HTP! Read what High-Fidelity Magazine says:

*"It's best to try a speaker at home before buying."*

—Audio Forum Dept., Oct. 1954 issue

FOR A LIMITED TIME ONLY: Every HTP participant will receive, absolutely FREE, the new Permoflux "Maestro" Speaker-Headset Control Box. See your Permoflux-authorized HTP dealer, or write for full details, to:

Permoflux CORPORATION

4902 West Grand Avenue • Chicago 39, Illinois

West Coast Plant • 4101 San Fernando Road • Glendale 4, California  
Canadian Licensee • Campbell Manufacturing Co., Ltd., Toronto, Canada

free

# send for ALLIED'S SPECIAL NEW 64-PAGE HI-FI CATALOG



## A Typical ALLIED System Value



### "Space Saver II" Hi-Fi Phono System

Here's authentic Hi-Fi performance that fits in the smallest available space. No cabinets required. Carefully matched components just plug in. System includes: Knight 12-Watt Amplifier (featuring 3-position record compensation, bass and treble controls, loudness-volume control, response  $\pm 0.75$  db, 20-20,000 cps at 12 watts) in handsome metal case only  $3\frac{1}{2} \times 13 \times 10\frac{1}{4}$ "; Webcor 1127-270 3-Speed Changer (9 x 14 x 14" in Russet and Beige or Burgundy and Beige) with G.E. RPX-050 magnetic cartridge and dual-tip sapphire stylus; Electro-Voice "Baronet" folded horn enclosure with SP8-B speaker in mahogany or blonde finish ( $22\frac{1}{2} \times 14\frac{1}{2} \times 13\frac{3}{4}$ "). Complete, ready to plug in. Hi-Fi record included. Specify colors.

94 PA 159. Net only. . . . . \$167.25  
93 SX 312. Knight 12-Watt "Space Saver" Amplifier only. Shpg. wt., 14 lbs. Net only. . . . . \$59.50

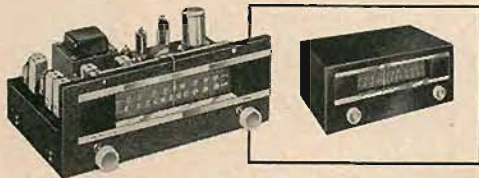

### New Knight 728 FM-AM Tuner—Our Top Value

Designed to ALLIED's highest specifications—equals the best at incomparably low cost. Maximum AM reception, thrilling on FM. Features: AFC on FM—"locks in" the station; two simple controls; sensitivity—FM, 5 mv for 20 db quieting, AM, 5 mv for 1 volt output; response, 50-15,000 cps,  $\pm 1$  db; tunes FM, 88-108 mc, AM, 530-1650 kc; output level—FM, 4 volts high imp., AM, 1 volt high imp.; hum, 60 db below output; outputs for amplifier and tape recorder; 300 ohm FM antenna input, AM, high imp. loop or antenna. Only  $5\frac{1}{2} \times 13\frac{3}{8} \times 7\frac{1}{2}$ " deep. Complete with FM-AM antenna.  
94 SX 728. Net only. . . . . \$89.50  
94 SX 729. Tuner as above in handsome black and gold finished metal cabinet.  $6 \times 13\frac{3}{8} \times 8\frac{3}{8}$ ". Net. . . \$95.50

Your guide to a complete understanding of Hi-Fi—plus the world's largest selection of Hi-Fi systems and components

This 64-page book shows you how to select a High Fidelity music system at lowest cost. Tells you simply and clearly what to look for in each unit. Shows many handsome, practical do-it-yourself installation ideas. Offers you the world's largest selection of complete systems and individual units (amplifiers, tuners, speakers, enclosures, changers, recorders and accessories) from which to make your money-saving choice. To understand Hi-Fi, to own the best for less, you'll want this FREE book. Write for it today.

### EXPERT HI-FI HELP

Our Hi-Fi consultants are always available to help you select components and systems to satisfy your listening desires at the lowest possible cost to you.

### EASY TERMS

Hi-Fi is available from ALLIED on easy payments: only 10% down, 12 full months to pay. Write for details.

## ALLIED RADIO

America's Hi-Fi Center

ALLIED RADIO CORP., Dept. 17-B-5  
100 N. Western Ave., Chicago 80, Ill.

Send FREE 64-Page Hi-Fi Catalog

Ship the following: \_\_\_\_\_  
\$ \_\_\_\_\_ enclosed

Name \_\_\_\_\_

Address \_\_\_\_\_

City \_\_\_\_\_ Zone \_\_\_\_\_ State \_\_\_\_\_

Send for FREE  
HI-FI CATALOG!

If you want a lyric-type comparison to the Wuehrer piano dynamism, try Badura-Skoda on Westminster (or the team of Skoda and Demus in four-hand Schubert piano).

**Beethoven: Piano Sonatas #1, #2 (Op. 2, #1 and #2). Friedrich Gulda.**  
London LL 996

Here is another intermittent series that is encompassing many of the Beethoven piano sonatas and I recommend Gulda as the most effective and accessible Beethoven pianist alive for the general listener.

There are pianists who play superb piano—Wuehrer, above, is one of them. Their playing makes you aware of the piano itself and its technique. But there are other, rarer pianists who seem, somehow, to transcend the instrument. We hear not piano, but music. For the listener who is not a piano specialist, these performers are by far the most enjoyable, and Gulda is 'way out ahead among them. (Others that come to mind are Schnabel, Rosita Renard, Gieseking, Badura-Skoda, Manahem Pressler, in various musical fields.)

My first—and most recent—experience with Gulda's Beethoven was his first disc for London, the Hammerklavier Sonata, LL-322. Among a group of five or six recordings it seemed to me to be absolutely extraordinary in its power to convey the musical sense, far beyond mere pianism, to the listener who also enjoys Beethoven's symphonic writing.

Thanks to the aforementioned London hiatus during the last year, I have not been able to hear a number of succeeding items by Gulda, but I do not hesitate to recommend them, sound unheard, as the finest examples of good piano for the general listener that you are ever likely to find. The present two sonatas, often hacked at ineffectually or stultily by other pianists, are in these Gulda playings near-miracles of easy, fluent, utterly natural music-making. No "steel-finger" stuff here; Gulda does not put piano-power ahead of musical expression.

If you want "digested" music, a la Music Appreciation, why not try this instead! This is Beethoven "digested," explained, made tremendously easy to hear, by sheer musicianship and understanding, without a word of comment or a single cut.

**Beethoven: Piano Concerto #1. Serkin;**  
Phila. Orch., Ormandy.

Columbia ML 4914

There never was a Serkin performance that lacked excitement and this is not an exception. Nevertheless, there is throughout the recording (as with a good many U.S. performances of the sort, compared to European equivalents) a certain indefinable tiredness, that spells "repertory." This is music that simply has been played too many times, by all concerned.

The same thing happens with Broadway plays, as we all know. The players are too good to muffle the lines or shirk the drama; the show is always good. But after months, or years, one begins to sense that odd effect of too much repetition: little slacknesses, almost unconscious, emotions put on by rote where once they were spontaneous, slight exaggerations, as though the players had to increase the dramatic effect in order to make up for their uneasy sense of incipient staleness.

Not that this is a poor performance of Beethoven—far from it. The basic values that Serkin found in the music long ago are still there and still make his interpretation sky-high in musical value. So, too, with Ormandy, who is particularly subject to this repertory kind of playing, considering the enormous output of music that he is asked to produce with his orchestra. But both have done better in the past.

Excellent recording, by the way; Columbia has indeed found an ideal and utterly natural balance between orchestra, piano and recording hall acoustics, with the piano for once at a decent stage-distance, as it should be in a concerto, instead of its too-usual position several inches from the nearest mike.

**Beethoven: Symphony #1; Egmont, Leonore III Overtures. Philharmonia Orch., Von Karajan.**  
Angel 35097

Like many a rising conductor, Von K. has been tackling all the repertory he can get hold of, with varying results; here, however, he shows his profoundly ingrained Viennese background in three beautifully Austrian-style performances of early and middle Beethoven.

By Austrian in this case I mean the tradition that we have heard so frequently in recordings such as Westminster's with the Konzerthaus Quartet and related groups—a leisurely, serious, very lyric playing of the Austrian classics, the tempi often slow, the softer outlines beautifully realized, the violent dynamics achieved more by contrast than by sheer hitting power, as in so many U.S.-made performances.

The First Symphony is played here, rightly, as mature Beethoven, not as a bit of humorous early-youthful fluff! It is far from that, and far more Beethoven than has been popularly admitted in the past. The "Egmont" slow introduction is a marvel of intense, moody ominousness, the rapid ecstasies of its later parts unhysterical and well controlled. (The neo-Toscanini school must blow off the roof at every performance!). So, too, with the great "Leonora III," which has been so over-tensed in recent performances that its lyric beauties have been almost forgotten.

With Angel's (EMI's) solidly conservative distant miking—not a trace of "super-hi-fi" effect here—this disc is a most welcome change from much recent hi-powered Beethoven.

Technical note: As mentioned above, Angel's recording curve would seem to leave the high end remarkably near to flat, with very little boost, requiring practically no roll-off for good reproduction. If it didn't contribute to more non-standardization, I would suggest that this is a good idea. The plastic surfaces can take it, and the sound, as reproduced flat, is wonderfully clean. But an overriding consideration is the need for uniformity of procedure, and so a clean New Orthophonic or RIAA curve is still the most desirable thing for all new records.

(Note that I may be misled here by the predominantly distant mike pickup in Angel records. Distant miking, with less strident and sharp highs, will tend to give the impression of less high-end intensity and may account entirely for the effect noted. Oppositely, very sharp and close miking as in some Vox and Westminster records may lead to an impression of unusually strong high boost, more so than is in fact the case.)

**Beethoven: Fidelio (semi-complete).** NBC Symphony—Toscanini broadcast of 1944. RCA Victor LM 6025 (2)

May I raise a small voice, amid the general encomiums, to suggest that, as the fable goes, in this case the Emperor's clothes aren't quite all they're cracked up to be. Whatever others say, my ear tells me that this is an interesting but very erratic performance of the Beethoven opera, in many ways inferior in spite of the Toscanini incitement to great drama. The singers are only so-so and in many places are simply unable to meet Toscanini's driving demands, becoming merely hysterical. The German diction is not good; much of the dialogue is omitted, to the detriment of the plot continuity, but that which is left is forced and silly, as though the speakers had no idea what they were saying. Through the whole—if you like it—is the usual Toscanini feeling of high tension, without adequate let-down into the glory of Beethoven's un-tense lyricism. Not enough is made of the "valleys," too much is placed on the peaks of intensity.

Moreover, it seems to me a shame that, in its enthusiasm, RCA has issued this recording on the standard label. It is a good job for its time, 1944, and the added liveness (repairing the original broadcast's extreme dead sound) is beautifully done. But nevertheless, there are no highs in this job to speak of and the vocal recording, done originally on discs, is far below current standards. The fact that standard labeling, instead of the Gold-label "Treasury" designation, undoubtedly means larger sales and that few buyers will be seriously disturbed by the technical deficiencies still leaves it up to this department to point out that many a technically better recording has been placed in the "Treasury" category by RCA Victor, as not up to present hi-fi requirements.

Frankly, I don't think this will live as the ultimate in "Fidelio" recordings.

## LOOKING 'EM OVER

**I Musici** (3 volumes). (Italian Music for Strings, 17th to 19th c.).

Angel 35086/7/8

**Torelli: Twelve Concerti, Op. 8.** Pro Musica, Stuttgart, Rolf Reinhardt.

Vox DL 113 (3)

AUDIO • FEBRUARY, 1955

## a new experience in INTEGRATED SOUND



### THE FAIRCHILD 240 Balanced-Bar PREAMPLIFIER

This amazing preamplifier lets you custom-tailor sound to fit the exact acoustical characteristics of your own listening room!

Just recently perfected by Fairchild, this brand-new Balanced-Bar 240 brings professional quality, and outstanding adaptability to home systems. Balance-Bar control integrates the tonal quality of your high fidelity systems with the particular require-

ments of your home. You can be sure that your records will receive the most accurate, most satisfying equalization possible.

Also, the Fairchild 240 features an extraordinary Listening Level Control. Operating independently of volume control, the LLC provides pleasant low-level listening and *correctly balanced* normal listening levels—all easily, without complex adjustments.

**\$98.50**

**HIGHEST LEVEL — LOWEST NOISE:** Fairchild 240 is capable of higher gain than any other preamplifier designed for home use. Voltage gain of 68 db drives your power amplifier to full output with one millivolt input signal! The famous Cascode design, in use in radar and television, offers an inherently quieter circuit.

**LOOK  
at these  
additional  
features . .**

**ATTRACTIVE DESIGN:** Graceful and fashion wise, this exciting cabinet matches any decor, any interior styling.

**SIMPLICITY OF OPERATION:** The Fairchild 240 performs every function of the high quality preamplifier-equalizer, using only two control knobs in normal operation. Yet, it features a complete range of controls with flexibility to satisfy the most avid audio fan.

## Performance guaranteed!

### FAIRCHILD 50 watt AUDIO AMPLIFIER

Fairchild's new 260 Power Amplifier is so stable that it is unconditionally guaranteed not to ring at any loading condition!

Full 50 watts of undistorted power is continuously available to accommodate crescendos and peaks which overload ordinary amplifiers. Yet, this compact Fairchild 260 is a single unit easy to install almost anywhere. **\$149.50**

- \* No ringing at any level
- \* Output unaffected by load power factor
- \* Exceptional stability
- \* Exclusive distortion-cancelling adjustment



# FAIRCHILD RECORDING EQUIPMENT

9th AVE & 154th ST., WHITESTONE, N. Y.

enjoy  
professional  
turntable  
performance...

plus fully  
automatic  
operation...



# THORENS audiomatic player

CBA-83

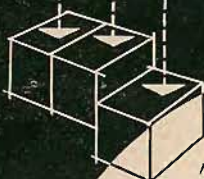

*"The Hand Never  
Touches The Tone-Arm"*

With a THORENS AUDIOMATIC, there is no possibility of record damage caused by an unsteady hand on the tone-arm. You simply press a button for 7", 10" or 12" records... and the tone-arm automatically lowers into the lead-in groove. After play, the arm returns... the motor shuts off! Because of the *direct-gear drive*, AUDIOMATIC has absolute speed regularity... and a noise level -48 db below recording level! Thus, you enjoy the advantages of automatic operation and performance *comparable to transcription turntables costing twice as much.* \$67<sup>50</sup>/<sub>net</sub>

**THORENS**

NEW HYDE PARK



Music Boxes  
SWISS Hi-Fi Components  
MADE Spring-Powered Shavers  
Lighters

NEW YORK

SEE YOUR DEALER

Also a complete  
line of hi-fi  
record changers  
and transcription  
turntables.  
Brochure  
upon request.

Here are two more vast collections of the increasingly popular 18th century Italian music for strings, of the type best known previously in the works of Vivaldi, and these make an interesting contrast in interpretation.

My vote goes, perhaps surprisingly, to the German interpretation of Italian music, the collection of a dozen concerti grossi (with two solo violins) by a lesser master of the time of Vivaldi and in a similar style. (The Torelli album is a companion-sequel to Vox's notable recent one of Vivaldi's "La Stravaganza," another set of twelve concerti.)

"I Musici" ("The Musicians") play a more varied program, centering upon the same type of music but with both earlier (Gabrieli) and later (Rossini) pieces as well. The musical interest here is actually greater than in the Torelli set, and the playing is more dynamic. But the approach very different. The German playing is straightforward, business-like and entirely in style; the music is played in the original scoring. The normal and essential contrast between the soloists (two violins) and the massive orchestral "tutti" framework is taken for granted, as is the solid harpsichord accompaniment. These things are not mere scholarship. They make musical sense because they are what was intended in the first place.

"I Musici," on the other hand, plays its music in arrangements, by various people. It performs as a group of virtuoso soloists without a conductor, and as a result the basic feeling of the concerto form is often confused, by a kind of super-chamber-music approach, that makes everybody a soloist. The very hall-marks of earlier style, the solo-tutti contrast and the omnipresent harpsichord continuo accompaniment, are sometimes present, sometimes absent in an erratic and inconsistent manner.

Don't let this discourage you from trying both sets. The music in "I Musici" is of wide appeal and the predominantly virtuoso approach, though it gets on my nerves, admittedly has an electricity about it that is attention-demanding. But if you like your music straight and natural, the solid virtues of the less exciting Torelli album will win out in the end.

**Bach: Magnificat.** Chorus Radio Stuttgart, Soloists, Pro Musica Orch., Reinhardt.

Vox PL 8890

**Bach: Coffee Cantata; Amore Traditore.** Soloists, Pro Musica Orch., Reinhardt.

Vox PL 8980

While we're at it, note these two excellent Bach discs with the same performers as the Torelli above. The festive "Magnificat" with its three trumpets, lovely solos, short vigorous choruses, is perhaps the easiest of Bach's bigger choral works to like. This is an "authentic" performance, a bit heavy in spots, some tempi very slow, but the spirit is good and the joy—plus the joyful instrumental and vocal color—gets through. Star singer is the superbly agile and fresh soprano, Friederike Sailer, worth the whole record to hear.

The "Coffee Cantata" is a fat, comfortable, good humored farce about the coffee craze then at its height in Germany. (It was probably performed in a coffee house.) Daughter indulges, Papa says naughty, naughty, she won't stop—until he threatens to cut her off without a husband. But she wins in the end. Final moral: "Mama likes coffee, Grandma likes coffee, how can you blame Daughter?" The same Friederike Sailer makes a wonderfully sparkling and impudent daughter, singing the folkish tunes with both musicianship and gusto, while Papa Bruno Müller is suitably stuffy.

"Amore Traditore" is a three-piece Italian-text show-piece for baritone and keyboard accompaniment. Handel wrote much such music, but this seems to be rather doubtfully attributed to Bach. The Italian is "Germanic Italian," probably by a German. The big resonant sound of baritone Müller is fine, but the harpsichord accompaniment is played with a didactic rigidity of tempo that makes the whole rather hard listening. Not too good.

**Bach: Partitas #2 and #3 for Unaccompanied Violin.** Zino Francescatti.

Columbia ML 4935

Fine stuff if you fancy fiddle music, but be wary if you are merely a Bach lover. First, these were originally intended for the old arched bow,



**SOME THINGS CAN'T BE RUSHED**

**IT TAKES TIME  
TO DRIVE  
SOME THINGS HOME...**

...and it takes time to make a good recording disc

This is the era of short cuts in every industry. But PRESTO will not cut corners—or cut quality. There are six basic steps in making a PRESTO Recording Disc... and not a single step is ever hurried.

PRESTO's great investment of time... pays off in dividends for you. It assures you of the most brilliant performance in recording discs, and the greatest permanence as well.

**PRESTO GREEN · ORANGE · BROWN  
AND WHITE LABEL DISCS ARE  
USED THROUGHOUT THE  
WORLD—WHEREVER  
FINE RECORDING IS DONE**



**PRESTO** RECORDING CORPORATION  
PARAMUS, NEW JERSEY

Export Division: | 25 Warren Street, New York 7, N. Y.  
Canadian Division: | Instantaneous Recording Service, 42 Lombard St., Toronto

**WORLD'S LARGEST MANUFACTURER OF PRECISION RECORDING EQUIPMENT AND DISCS**



**TIME CONSUMING  
STEP #2  
IN MAKING A PRESTO  
RECORDING DISC**

Lacquer "makes" the surface of a recording disc. That's why PRESTO has a special lacquer formula and guards it as closely as atomic material. It is stored in constantly-agitated vats to insure even consistency. It is slowly flowed on to the polished aluminum blanks to precisely the thickness required. Then comes the long, leisurely, 1½ hour trip of the discs through the processing tunnel. PRESTO wouldn't shorten this trip by a second... because *time* is of the essence in making a fine recording disc.



which could play chords; no modern fiddler can do more than scoop at the chords and so the musical sense must be inferred by the ear. (It's superb sense if you can get the message, so to speak.) Second, Francescatti plays these right out of violin school, with plenty of polish but very little sense of Bach; there is entirely too much dramatic sliding and scraping in the best 19th century Paganini manner. Intentional—for F. is one of the finest violinists of our time. But, as I say, this is playing for violin-lovers, not Bach lovers. (I think I'd prefer Heifetz's more straightforward playing in the RCA Victor complete recording. If you want to hear the old arched bow, try the Columbia album of all the unaccompanied sonatas and partitas, played in the original style.)

**Music of the Baroque Era for Harpsichord and Clavichord. Erwin Bodky. Unicorn UN 1002**

Interesting recording of a group of strong and interesting background pieces of the Bach and pre-Bach era. (Background in the sense that these are lesser but still big composers of their time.)

The playing is masculine and excellent, musically, on both instruments. Nothing delicate and perfumed here! But perhaps of greater interest to audiophiles is the well-managed volume balance between the two. The relatively powerful harpsichord occupies the outer bands on each side of the record, the first and the last; between them is a central band of clavichord at a much lower level—the proper relative volume as between the two instruments.

Good plastic and the level-determining harpsichord bands make this possible, where otherwise the clavichord would have to be recorded at the normal and much higher level. Set the beginning for right volume and the middle bands assume their correct—and extremely faint—loudness relationship.

Since there is virtually no liveness in these recordings you may play them as Absolute recordings; that is, play at the actual original sound level of the instruments. Since they have no incorporated room-sound to bring with them, you may place these two keyboard instruments right in your room, or anywhere else that you put your loudspeaker. But remember, the loudness must be fixed, absolute.

**Handel: Water Music (Complete). Hewitt Orch., M. Hewitt.**

**Haydn Society HSL-107**

This is, I think, the third complete Water Music since LP came in; others I've heard are one from Washington, D.C. and one from Germany. This is a French version (the Hewitt Orchestra is French, despite the name) and it has a new flavor, notably the tell-tale braying vibrato of the French French horns, unlike those of other countries. ("Ordinary" horns play without vibrato, are larger and deeper-toned than the French instruments. The "French" horns we usually hear are actually of German origin.)

The Water Music is the very stuff of real musical entertainment. How dismally have we lost the knack of composing top-quality music that is directly and intentionally a high-quality decorative background, not in the sense of our modern wired music but in the sense of our beautiful interior decoration, rich furniture, tableware, and so on!

We have a wonderful feeling for visual decoration. We know how to make it both pleasing, useful, decorative and fine art as well. But in music either we compose "serious" music that requires really tough listening, or entertainment music that's full of platitudes and says nothing.

If you want to hear how Handel did it, try this—and imagine it coming from a river barge!

Special Note. As an alternative approach to these more detailed record discussions, next month I'll try a new kind of round-up-in-brief. We'll title it "Looking 'Em Over." The records won't necessarily be of less interest than those treated to longer comment. But we can't cover everything in detail that is worth the extended coverage—not without a 500-page issue every other month! Better a short note than none at all.

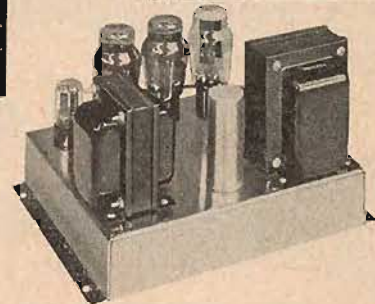
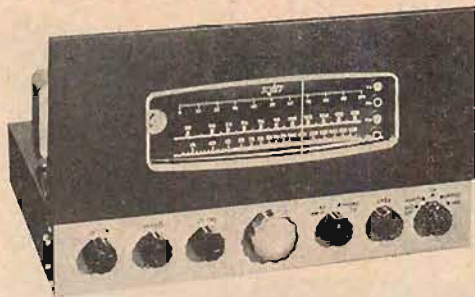

**FM - AM Tuners and High Fidelity Amplifiers**

- vital new engineering advances . . . from SCOTT Laboratories . . . specialists in high fidelity for 28 years.
- a new Series 5000 FM-AM Tuner and High Fidelity Amplifiers . . . offering frequency range and compensation not previously achieved.

**Pattern 500TX FM-AM Tuner and Power Amplifier**

New FM-AM tuner has automatic gain control. Pre-amplifier provides gain for low level pickups, tape recorders, etc. Selector switch gives automatic compensation for NARTB, LP, ORTHO, AES, RIAA, recording standards. Genuine leather tuning panel. Tandem connected 20-watt power amplifier in separate chassis for thermal and electrical isolation. Both chassis in gleaming chrome. Net . . . . . \$395.00.

**Pattern 5012X FM-AM Tuner and Pre-Amplifier**

Tuner and pre-amplifier with automatic compensation selector for recording standards, self-contained power supply and cathode-follower output termination, for use with any power amplifier. Otherwise, features same as Pattern 5001X. Net. . . . . \$250.00.

**Pattern 6001X Pre-Amp Equalizer and Power Amplifier**

A finer concept of high fidelity performance and convenience. The control console houses pre-amplifier for low level inputs, input channel selector switch, dual tone compensators, master level control and compensation selector switch for NARTB, LP, ORTHO, AES, RIAA, recording standards. Separate power amplifier chassis provides 20-watt high fidelity output. Both chassis in gleaming chrome. Net . . . . . \$175.00.

Write for Engineering Data

Send me full engineering data on the new SCOTT High Fidelity Tuners and Power Amplifiers.

Name . . . . .

Address . . . . .

City . . . . . State . . . . .



**Radio Laboratories, Inc.**

Plymouth, Ind., - display • 1020 N. Rush St., Chicago, Ill.

**NOW! YOU SAVE UP TO \$50**

**WHEN YOU BUY A REALIST**

**HI-FI TUNER AT RADIO SHACK**

1955 MODELS! HUNDREDS SOLD TO ENTHUSIASTIC USERS!



**FM TUNER \$39.95**

- ARMSTRONG FM WITH FOSTER-SEELEY DISCRIMINATOR!
- 5 MICROVOLT SENSITIVITY FOR 30 DB QUIETING!
- TUNED RF STAGE! DOUBLE-TUNED LIMITER! AC SUPPLY!
- AUTOMATIC FREQUENCY CONTROL (AFC)! 180kc BANDWIDTH!
- AUDIO OUTPUT 1V FOR 100% MODULATION! HUM 60 DB DOWN!
- FREQUENCY RESPONSE 20-20,000 CYCLES PLUS-MINUS 1/2 DB!
- DIRECT-FEED TAPE RECORDER JACK! AUX. PHONO INPUT!
- POWER AND TUNING CONTROLS — USE WITH ANY AMPLIFIER!
- ULTRA-COMPACT 4 1/4" H x 9 1/2" W x 6 3/8" D! COMPLETE!
- ORDER NO. 36-888M BY MAIL! ADD POSTAGE FOR 6 1/4 LBS.



**AM TUNER \$29.95**

- EXACT MATCH OF REALIST FM TUNER! SAME COMPACT SIZE!
- TUNED RF STAGE! AC SUPERHET CIRCUIT! AC SUPPLY!
- 5 MICROVOLT SENSITIVITY! 8kc BANDWIDTH 6 DB DOWN!
- BUILT-IN FERRITE STICK ANTENNA! BUILT-IN TAPE JACK!
- PLUS-MINUS 3 DB 20-5000 CYCLES! HUM 60 DB DOWN!
- POWER AND TUNING CONTROLS — USE WITH ANY AMPLIFIER!
- ORDER NO. 36-887M BY MAIL! ADD POSTAGE FOR 6 1/4 LBS.

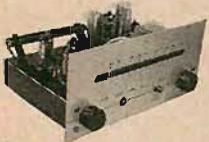

**REALIST 10 WATT HI-FI AMPLIFIER!**

- BUILT-IN RIAA-EQUALIZED PREAMP!
- 20-20,000 CPS ±1 DB AT 3 WATTS!
- SEPARATE BASS AND TREBLE CONTROLS!
- 5 TUBES! PUSH-PULL TWO 6V6GT!
- ORDER NO. 33-303M BY MAIL! 10 LBS.

**\$29<sup>95</sup>**

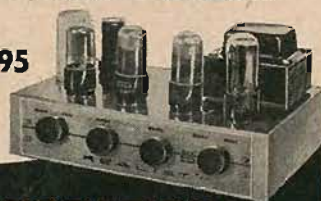

**RADIO SHACK CORPORATION**

167 Washington Street, Boston 8, Massachusetts  
and 230-234 Crown St., New Haven 10, Conn.

**AUDIO FAIR—Los Angeles**

(from page 30)

- |  |          |
|--|----------|
| KLIPSCH & ASSOCIATES<br>P. O. Box 64, Hope, Arkansas<br>In Attendance: Paul W. Klipsch                               | 621      |
| JAMES LANSING SOUND, INC.<br>2439 Fletcher Drive, Los Angeles 39, Calif.<br>In Attendance: Lowell H. Jordan          | 660      |
| LONDON RECORDS OF CALIFORNIA<br>445 S. La Brea, Los Angeles, Calif.<br>In Attendance: R. P. Kontner                  | 443      |
| MAGNECORD, INC.<br>1101 S. Kilbourn Ave., Chicago 24, Ill.<br>In Attendance: James R. Butler                         | 661      |
| S. B. MARANTZ<br>P. O. Box 201 Altadena, Calif.<br>In Attendance: Ralph Auf Der Heide                                | 686      |
| MASCO (Mark Simpson Mfg. Co., Inc.)<br>8346 Beverly Blvd., Los Angeles, Calif.<br>In Attendance: Roy Smith           | 485      |
| McINTOSH LABORATORY, INC.<br>320 Water St., Binghamton, N. Y.<br>In Attendance: Maurice L. Painchaud                 | 656      |
| MERCURY RECORD CORPORATION<br>2958 W. Pico Blvd., Los Angeles, Calif.<br>In Attendance: Ronald Wise                  | 538      |
| MINNESOTA MINING AND<br>MANUFACTURING CO.<br>900 Fauquier Ave., St. Paul, Minn.<br>In Attendance: C. G. Westcott     | 340      |
| NATIONAL COMPANY, INC.<br>61 Sherman St., Malden, Mass.<br>In Attendance: C. G. Barker                               | 460, 461 |
| NEWCOMB AUDIO PRODUCTS CO.<br>6824 Lexington Ave., Hollywood 38, Calif.<br>In Attendance: Robert Newcomb             | 579      |
| OMEGA TAPE (Int'l Pac. Rec. Corp.)<br>7511 Santa Monica Blvd., Hollywood 46,<br>Calif.<br>In Attendance: Dave Hubert | 638      |
| ORRAD INDUSTRIES, INC.<br>Opelika, Alabama<br>In Attendance: Nat Welch   | 643      |
| THE PENTRON CORPORATION<br>777 South Tripp Ave., Chicago, Ill.<br>In Attendance: Martin Mann                         | 561      |
| PERLMUTH-COLMAN & ASSOCIATES<br>2419 S. Grand Ave., Los Angeles 7, Calif.<br>In Attendance: Jack J. Perlmuth         | 309      |
| PERMOFLUX CORPORATION<br>8346 Beverly Blvd., Los Angeles, Calif.<br>In Attendance: Roy Smith                         | 485      |
| PICKERING & CO. INC.<br>8346 Beverly Blvd., Los Angeles, Calif.<br>In Attendance: Roy Smith                          | 485      |
| PILOT RADIO CORPORATION<br>1865 N. Western Ave., Los Angeles, Calif.<br>In Attendance: Conrad Strassner              | 560      |
| PRESS ROOM   | 539      |
| THE RADIO CRAFTSMEN, INC.<br>1141 S. La Cienega, Los Angeles, Calif.<br>In Attendance: Jack Berman                   | 585, 586 |

- RADIO ELECTRONICS 435  
25 W. Broadway, New York 7, N. Y.  
In Attendance: Lee Robinson
- RADIO MAGAZINES, INC. 543  
P. O. Box 629, Mineola, N. Y.  
In Attendance: C. G. McProud
- REEVES SOUNDCRAFT CORPORATION 663  
1429 N. Vista St., Hollywood 46, Calif.  
In Attendance: Wayne Graham
- REGENCY DIVISION, I.D.E.A., INC. 612  
7900 Pendleton Pike, Indianapolis, Ind.  
In Attendance: Bea Jones
- REK-O-KUT COMPANY 412  
38-01 Queens Blvd., Long Island City 1, N. Y.  
In Attendance: Avery Yudin
- REVERE CAMERA CO. 337, 338  
320 E. 21st St., Chicago 16, Ill.  
In Attendance: David Gassner
- ROCKBAR CORPORATION 585, 586  
1141 S. La Cienega, Los Angeles, Calif.  
In Attendance: Jack Berman
- SARGENT-RAYMENT CO. 518  
1401 Middle Harbor Road, Oakland, Calif.  
In Attendance: Jerry S. Frank
- HERMON HOSMER SCOTT, INC. 556  
385 Putnam Ave., Cambridge 39, Mass.  
In Attendance: Victor H. Pomper
- SONOTONE CORPORATION 421  
Elmsford, N. Y.  
In Attendance: Robert M. Mitchell
- STEPHENS MANUFACTURING CORPORATION 479  
8538 Warner Drive, Culver City, Calif.  
In Attendance: Robert L. Stephens
- TECHNICAL TAPE CORPORATION 442  
177th St. & Harlem River Terrace,  
Morris Heights 53, N. Y.  
In Attendance: Frederick I. Kantor
- TELECTROSONIC CORPORATION 465  
35-18 37th St., Long Island City 1, N. Y.  
In Attendance: David Libsohn
- THE TETRAD COMPANY, INC. 481  
62 St. Mary St., Yonkers, N. Y.  
In Attendance: E. J. Marcus
- THEME MAGAZINE 638  
4253 Farmdale Ave., North Hollywood, Calif.  
In Attendance: A. James Valentine
- THORENS COMPANY 665  
New Hyde Park, N. Y.  
In Attendance: P. W. Kind
- TUNG-SOL ELECTRIC, INC. 640  
95 Eighth Ave., Newark 4, N. J.  
In Attendance: R. M. Andrews
- UNIVERSITY LOUDSPEAKERS, INC. 509  
80 S. Kensico Ave., White Plains, N. Y.  
In Attendance: Larry Epstein
- V-M CORPORATION 420  
4216 W. Jefferson Blvd., Los Angeles, Calif.  
In Attendance: Joe Marsh
- WEBSTER-CHICAGO CORPORATION 606  
1148 S. Grand Ave., Los Angeles, Calif.  
In Attendance: George S. Tivy
- WESTMINSTER RECORDING CO., INC. 321  
275 Seventh Ave., New York 1, N. Y.  
In Attendance: Henry L. Gage

## Crestwood brings you new features...new models for 1955

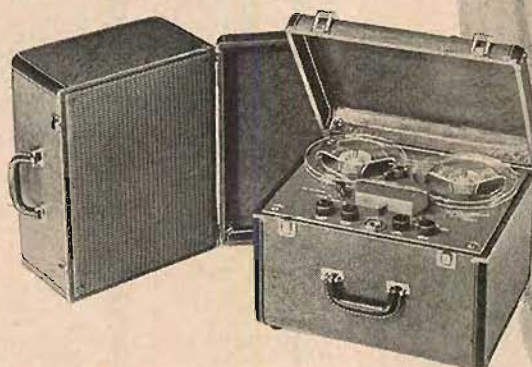

CRESTWOOD new model 404 offers high fidelity response. (30 to 15,000 cycles at 7½" per second tape speed.) Gives you crystal clear performance — free from wow, hum and distortion . . . combined with model 402 power amplifier and speaker makes a two-case portable package . . . fits nicely into your hi-fi system and your budget, too!

Exceptional fidelity (50 to 10,000 cycles at 7½" per second tape speed) is featured in the new CRESTWOOD 304. New tape transport mechanism and professional type recording heads make the 304 one of the best values ever offered in a tape recorder . . . includes internal speaker, microphone, radio and TV connection cable.



The new CRESTWOOD consoles move tape recording enjoyment into a permanent and prominent position in your living room, den or recreation room . . . instantly ready to record or reproduce. Extended range dynamic speakers — fully baffled for complete range reproduction — give you truly outstanding sound quality . . . Choice of 300 or 400 Model Series in hand rubbed cabinets.

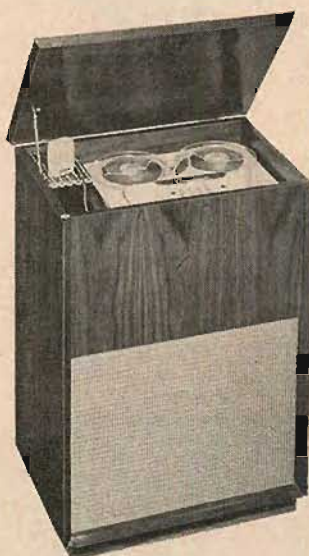

*Crestwood*<sup>®</sup>  
BY DAYSTROM

Hear These New Crestwoods  
at the  
Los Angeles Audio Fair  
Feb. 10 to 13—Room 584

Daystrom Electric Corp.  
Dept. 29B  
753 Main Street, Poughkeepsie, N. Y.

Please send me information and specification sheets on the new CRESTWOOD models.

Name \_\_\_\_\_

Street \_\_\_\_\_

Town \_\_\_\_\_ State \_\_\_\_\_

# NEW PRODUCTS

• **Flutter and Wow Meter.** Determination of the constancy of motion in a recording or reproducing system is an easy procedure with this new portable instrument designed to measure wow and flutter at 3 kc. Designated Model FL-3B, the unit fulfills a need for an accurate, low-cost instrument for this purpose. An exceptional feature of the FL-3B is an internal 3-kc oscillator which eliminates the need for additional equipment to generate a measuring signal. The stability of the oscillator, factory adjusted to a secondary frequency standard, is a further advantage since it removes the necessity for constant adjustment posed by broad-band R-C oscillators. The instrument gives full limiting with an input signal of 0.4 volts

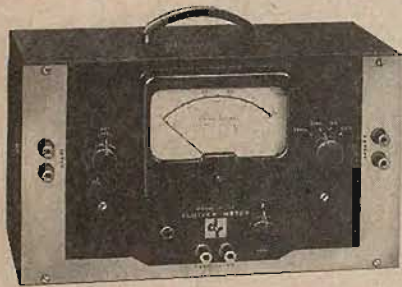

rms, thus permitting measurements to be taken from a standard 0 dbm program line. Input impedance is 250,000 ohms, one side grounded. Scale readings are 0.5 and 2 per cent, full scale. Dimensions are 7 x 12 x 6 ins. and weight is 9 3/4 lbs. Power consumption is 20 watts at 117 volts a.c. Manufactured by D & R, Ltd., 402 E. Gutierrez St., Santa Barbara, Calif.

• **Pilot Preamplifier-Equalizer.** Although priced well within the range of the average consumer, the new Pilotrol Model PA-913 incorporates many operating features which are normally expected only in professional equipment. A complete audio control unit, the PA-913 is equipped with a db meter, pushbutton selection of input channels with illuminated indicators, and provision for mixing a microphone with any other input channel. Variable phono preamplifier input loading is provided for precise impedance match with all magnetic-type cartridges. Pushbutton controls permit five positions of treble roll-off and bass turnover for precise record equalization. Voltage output is 5 volts maximum.



Frequency response is 20 to 20,000 cps within  $\pm 1$  db. Separate bass and treble tone controls range from 19 db boost to 19 db cut at 20 and 20,000 cps, respectively. Both harmonic distortion and intermodulation are under 0.2 per cent at 1 volt output. Illustrated free brochure is available from the manufacturer, Pilot Radio Corporation, 37-06 36th St., Long Island City 1, N. Y.

• **Recoton Magnetic Cartridge.** Both excellent performance and exceptional economy are embodied in the new Model 500 magnetic cartridge recently introduced by Recoton Corporation, 147 W. 22nd St., New York 11, N. Y. The 500 is a cartridge of the turnover type, using separate styli for 78's and 33's. It may be easily installed in any tone arm equipped with standard half-inch-center mounting holes. Unique among features of the unit is its push-pull coil assembly which cancels out hum originating in turntable motors and nearby electrical appliances. Frequency

response is virtually flat from 20 to 16,000 cps. High compliance and low moving mass permit excellent tracking at 6 to 7 grams, with distortion reduced to a practi-

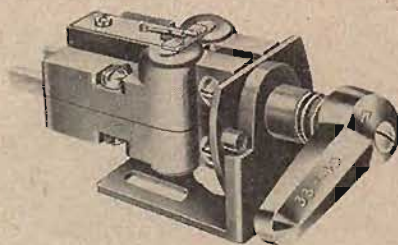

cal minimum. The 500 may be purchased with either sapphire or diamond styli in any desired combination. Technical sheet available upon request.

• **Bozak Speaker Enclosure.** Newest addition to the line of speakers and enclosures manufactured by The R. T. Bozak Company, Darien, Conn., is the Model E-300 cabinet which is designed specifically for infinite baffling of the Bozak Model 207A coaxial speaker. Frequency response of the speaker-enclosure combination is 45

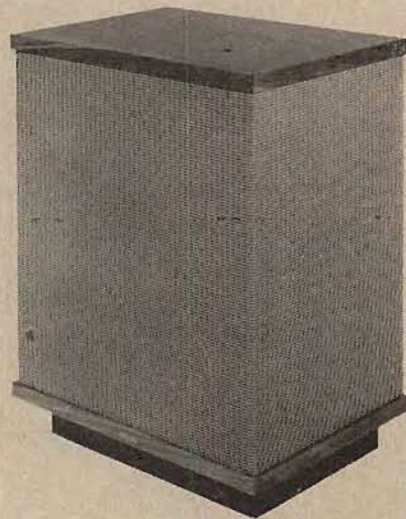

to 16,000 cps. Available in mahogany, walnut and birch, the E-300 measures 24" w x 17" d x 30 1/2" h and weighs approximately 50 lbs. without speakers.

• **Variable Dip Filter.** A variable high- and low-frequency filter designed for elimination of unwanted noises in sound reproduction is the newest item to be added to the line of audio equipment manufactured by Cinema Engineering Company Division of Aerovox Corporation, 1100 Chestnut St., Burbank, Calif. Known as Type 7052 Variable Frequency Dip Filter, the unit has a frequency range of 20 to 15,000 cps. It incorporates a 4-stage amplifier having an R-C interstage coupling network. Technical features include triple Mu-metal shielding of transformers, shock mounting of tubes, and

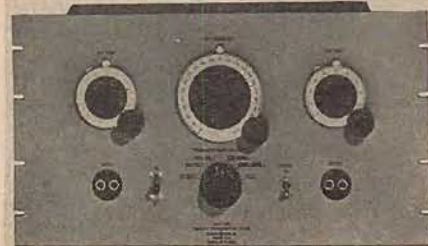

general electrostatic and electromagnetic shielding to permit operation in low-level circuits. Output level is minus 2 dbm with output impedances to work into 200/250 and 500/600 ohm balanced lines.

• **Low-Cost Tape Recorder.** Among features stated by the manufacturer to be inherent in the new Tri-Fy Dixieland tape recorder are frequency response to 7500 cps, flutter and wow less than 0.5 per cent, and exclusive tape-guide for ease of threading. Mechanical drive, bearings,



flywheels, and other vital parts are die-cast for close tolerances and rigidity. A two-speed unit, the recorder is housed in an attractive carrying case, and is supplied complete with microphone. Manufactured by Tape Recorders, Inc., 1501 W. Congress St., Chicago 7, Ill.

• **Printed-Circuit Amplifier Assembly.** Substantial economies can be achieved in the production of low-cost phonographs, intercommunication systems, and similar audio equipment through the use of a new, compact, printed-circuit amplifier assembly recently introduced by Photocircuits Corporation, Glen Cove, N. Y. Although only 2 1/2" w x 4 1/4" d x 1 1/4" h, exclusive of control shafts, the two-stage unit has an output rating of two watts. It can be used alone as an amplifier, or

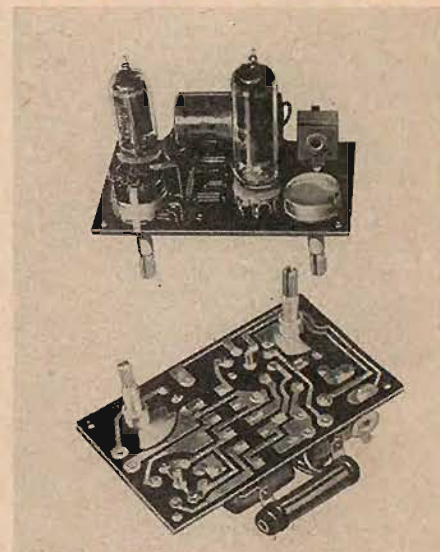

can be incorporated into other equipment as a sub-assembly. Except for an output transformer, it is complete in every respect, including volume and tone controls. Frequency response is said by the manufacturer to be flat to 8000 cps. Input voltage required is 0.2 volt for full output. Power required is 24 watts at line voltage. Tube complement consists of a 12AT6 voltage amplifier driving a 50B5 output stage. The power supply uses a selenium rectifier. Further information is available from the manufacturer.



# HARVEY the House of Audio

## New PICKERING TURN-OVER CARTRIDGE Model 260DS with Diamond and Sapphire Styli



Following the enthusiastic acceptance of the Model 260DD Dual Diamond Cartridge, Pickering now announces the Model 260DS with Sapphire stylus for standard and Diamond for microgroove. Both cartridges are otherwise identical.

Response is smooth and clean from 20 to 20,000 cycles. Lower moving mass and higher compliance provides excellent tracking at low stylus pressure, and good transient response. These and other design features result in lower harmonic and intermodulation distortion. The Model 260DS fits most pickup arms and operates directly into conventional low-level preamp inputs.

Model 260DS — Diamond-Sapphire..... \$4800  
Model 260DD — Dual Diamond..... 60.00



## The New MIRACORD

Model XA-100  
RECORD CHANGER

Embodying many innovations, the Miracord features the 'Magic Wand Spindle' designed in such a manner that at no time does it support a load greater than one record. Four push-buttons provide wide control flexibility. The START button also acts as a 'reject', for the purpose of switching to the next record. A PAUSE button permits a variation in the change interval between records: from 5 sec. at 78 rpm to 328 sec. at 33 1/2 rpm. The FILTER button introduces a 'scratch filter' that suppresses surface noise of old records. The REPEAT button replays the whole or any part of a record.

Both the turntable and arm are mounted in double ball-bearing races. A hum-shielded 4-pole motor further reduces vibration rumble and 'wow' to an inaudible minimum. Plug-in heads accommodate most standard pickup cartridges. A single-play spindle is also furnished which may be used for repeating a single record, over and over.

Complete with 6' line cord and 4' phono cord..... \$67.50

## New WARREN PORTABLE TAPE RECORDER Model 777

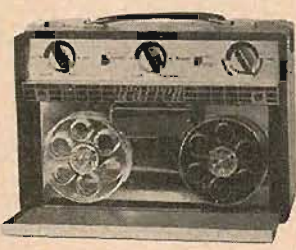

A complete, compact tape recorder and playback unit designed to operate from self-contained battery pack or external ac power source. Batteries provide 5 hours continuous operation and are recharged with built-in battery charger. Weighs 22 pounds, and measures only 6 x 10 x 15 inches. Accommodates standard 5-inch reels. Available in two models: Model 777—1.87 inches/sec, dual-track, response 200-4000 cps. Model 777-1—3.75 inches/sec, dual-track, response 200-6000 cps.

Complete with microphone, battery, reel of tape, take-up reel, built-in playback amplifier and speaker, and instructions..... \$298.00  
(specify Model 777 or 777-1)

## HI-FI SPECIAL! Famous Imported Output Tubes MATCHED KT-66 for Balanced Push-Pull Operation Replace: 6L6, 1614, and 5881 tubes

per pair ..... \$6.95

HARVEY SHIPS EVERYWHERE. Use this handy coupon ▶

NOTE: Prices Net, F.O.B., N.Y.C. Subject to change without notice

**HARVEY** ESTABLISHED 1927  
**RADIO COMPANY, INC.**  
103 W. 43rd Street, New York 36 • JU 2-1500

## The BELL Golden-Twin Units For High Fidelity Home Systems

Perfectly matched in performance and appearance. Designed for the critical eye as well as the discriminating ear.

### AM-FM Radio Tuner Model 2255



A compact, high quality AM-FM tuner. Fully enclosed in metal cabinet richly finished in satin gold and brown, with edge-lighted, slide-rule dial. Designed for open-shelf or table-top use as well as panel mounting. Grounded-grid input stage, double-tuned limiter, true Armstrong FM, AFC and low-distortion cathode follower output, all contribute to unusual sensitivity and stability. Has built-in ceramic ferrite AM antenna. Momentary AFC defeat switch on tuning knob permits accurate center of frequency tuning. FM Section provides 4 μV sensitivity for 20 db quieting... better than 33 db image rejection. Frequency response is 20-20,000 cps ± 1/2 db. Drift ± 3 kc with AFC. AM Section. Frequency response is 20-5000 cps ± 3 db. Maximum output is 3 volts with less than 1% distortion. Hum level 65 db below 100% modulation. Power supply is self-contained. Dimensions: 4" high, 9 1/2" wide, 8 3/4" deep. Weight: 9 lbs.

Complete with tubes..... \$99.95

### 12-Watt Audio Amplifier Model 2256



Fully enclosed in metal cabinet finished in soft gold and brown, intended for open-shelf or table-top use as well as panel mounting. A perfect twin in both appearance and performance to the Model 2255 Tuner, yet functions perfectly with other high fidelity components. Has built-in pre-amplifier and full set of controls.

Power Output is 12 watts with .5% distortion, 20 watts peak. Frequency response is 20-20,000 cps ± 1/2 db with controls set for flat response. Six inputs are provided for radio, crystal, pickup, two magnetic pickups, FM and ceramic pickups, tape or disc recorder or TV. Five front panel controls include: 7-position Selector Switch with provision for equalization to match all existing record curves, continuously variable loudness control, bass control: -18 to +15 db at 40 cps, treble control: -18 to +14 db at 15 kc, and radio level-set control on rear panel. Four outputs: 4, 8, 16 ohms plus high impedance jack for tape or disc recorder. Employs two 6V6 output tubes in push-pull. Dimensions: 4" high, 9 1/2" wide, 8 3/4" deep. Weight: 14 lbs. Complete with tubes..... \$89.95

## The NEW MAGNECORD M-90 TAPE RECORDER Now in Stock Write for Complete Details

## STROMBERG-CARLSON Model RF-471 SPEAKER SYSTEM

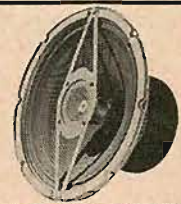

A co-axial speaker consisting of a 12 inch 'woofer' section and a 2-inch 'tweeter' with self-contained cross-over. Frequency response extends from 30 to 14,000 cycles when used in labyrinth enclosure. In infinite baffle, low frequency response limit is 50 cycles. Angle of coverage is better than 100°. Can handle 32 watts of power in program material. Impedance is 8 ohms..... \$49.95

HARVEY RADIO CO., Dept. A-2, 103 W. 43rd St., New York 36, N.Y.

Please ship the following.....

I enclose  check  money order for \$..... including estimated shipping charges. Unused surplus will be refunded.

Send:  New FREE High Fidelity Catalog  
 Details of your TIME PAYMENT PLAN

NAME.....

ADDRESS.....

City..... Zone..... State.....



sheer  
musical  
magic

the new **Rauland**  
model 1811 full 12 watt  
high fidelity amplifier

NOW, at moderate cost, you can own and enjoy a quality of musical re-creation virtually indistinguishable from the original performance. Here is the ideal "heart" for your home music system, capable of reproducing the full musical range from vibrant bass through thrilling treble with the full emotional depth and meaning of the original music. Here is the finest audio achievement, designed to bring you the ultimate in enduring listening pleasure.

with every desirable feature for superb musical reproduction...

- Full 12 watts output • Response,  $\pm 0.5$  db, 20-20,000 cps. • 3 Response Curves to bring out the full fidelity in all types and makes of records • Microphone input for entertainment and recording • Separate Bass and Treble tone controls • Choice of regular or "equal loudness" control
- Inputs for GE or Pickering cartridge, tape, tuner, and microphone • Removable panel for easy mounting...

PLUS every other desirable feature to create a new dimension in sound for your home.



Hear the RAULAND 1811 Amplifier at your Hi-Fi dealer, or write for full details.



**RAULAND-BORG CORPORATION**  
3515 W. Addison St., Dept. 2, Chicago 18, Ill.

# AUDIO *ETC.*

Edward Tatnall Canby

## Price Cuts and Double Liveness

**T**HE SUDDEN PRICE-CUT initiated by RCA Victor for disc records no doubt makes an adjustment, of earthquake proportions, for a situation that has long been developing impossible tensions. In New York, at least, very few people still were buying records at the so-called list price. Almost everybody expected, and got, a healthy discount. Evidently most buyers in small towns still paid the list and had their pleasure (or sent away mail order for the cut prices) but the "discount" was becoming more and more universal, just as the "net" price has become universal in the hi-fi audio field.

A reduction of the list price to the actually existing discount price, more or less, is a move a bit like the sudden devaluation of a currency to put it in line with its black market values. It hits a lot of people in the wrong place, as well as cleaning out a good deal of corruption and restoring a two-faced situation to a reasonable unity. This record price reduction has big benefits for the consumer, and also some rather deadly hurts for him, notably in the inevitable sensitive spot, the small record labels.

A year ago there was an abortive price cut of this sort. My remarks at that time need merely be intensified to apply right now, for this price cut, as of 1955, looks as if it might stick where the other one didn't.

Do not forget that the big record companies can afford the stress of a price war and a narrow profit margin, while the small companies cannot. And don't forget that we owe the extraordinary wide range of available record material in good part to the small companies. Not only the Esoterics and the Philharmonias and the Oiseaux-Lyres, but the Cook Records and the Audiophiles, as well.

If prices for LP's remain below \$3 list, a good many small companies are going to fold, or if they are clever enough, jettison most of their more specialized items in favor of "popular" stuff. That could mean a terrible loss in a hundred directions. We may have been paying extra-high for the standard large-selling items of the phonograph library these last years, but in return we have had the privilege of choosing from a vast quantity of material of less universal interest—among which almost surely are items which are absolutely essential to you or to me—and to heck with popularity. For a more prevalent low

price, we now may trade away a good part of this flexibility and it's going to hurt a lot.

It's hurt me already, for instance. One of those periodic recordings that I have made myself had been in the works for almost two years, what with editing, revising, negotiating; it is a tape of a number of choral works sung by the Dessoff Choir of New York, in which I am a second tenor. We had worked untold hours on this project, in the actual recording, the editing and re-editing, not to mention the music itself, and this last fall we triumphantly sold the tape complete to a New York record company.

The contract was about to come through when the price cut hit. Today the whole thing has been cancelled, for the moment and perhaps indefinitely; the company is thinking of getting out of the straight LP record business entirely, in favor of mail order work, and we are likely to lose not only this two years' effort but also our three or four earlier records that have sold in limited but steady quantities—at the old prices—not only all over the U.S. but quite widely in a number of European countries. To the Dessoff Choir this is disastrous; to the record company it means possibly dropping a major line of LP records that were, I think, the very first to appear on the market after Columbia's own, back in '49; and to you, the consumer, it means the disappearance—if and when—of a source of fine musical performances from America, Europe, and especially from Switzerland, that has been cumulative for all the years of LP existence.

I mention no names, because it's quite possible that this particular situation, and many another it typifies, will straighten out with not too much of a loss. Perhaps we'll be able to keep our contract after all and maybe the record will appear, even at the lower price. I'm not any too hopeful right now. And I cannot feel happy about a policy, in the name of big business, that can wipe out so many dozens and hundreds of individual man-hours of work and hope and accomplishment in small-company LP as this price cut bids fair to do.

### Silver lining?

Maybe it won't be so bad. Time will tell. I gather that, once things adjust a bit, the old discount habit will be taken up anew

as far as is possible, starting down from the new list price. It won't be as big, a discount, I should guess, but the general principle might still apply. I suspect that many a small and medium-sized company, too, will find ways to juggle its products into a new selling mode without undue loss. I only hope that good judgment will not always suggest that they dump everything but the best sellers. Stick to the tried and true. That would be really disastrous.

**Soundorama—Washington, D. C.**

I wasn't able to be present at the Soundorama, sponsored by a group of hi-fi equipment makers and station WGMS ("Good Music Station") of Washington, but on the basis of reports I have some side-comments that may intrigue a bit.

The Soundorama was held in Constitution Hall, an enormous place, fulfilling every idea that any hi-fi enthusiast might have of a concert hall. The plan was to have an actual symphony orchestra play in that hall, the National Symphony, with recording mikes and tape recorder (Berlant) in full view of the audience; then the music was to be played back hi-fi, via a battery of quality home-type amplifiers (Fisher) and loudspeaker systems (Jensen). The intention was, presumably, to show how "hi-" the "fi" could be in comparison to that ideal and absolute, the Actual Sound of the Concert Hall. It was, I hear, the first time such a thing has been done in public.

As I say, I'm not in a position to judge the results, alas. I gather only that the musical play-back was not of very long duration—possibly because, after all, the audience couldn't be expected to listen to the whole program twice.

However, you can think along with me about some rather special acoustical problems that were bound to arise. Just how, for instance, do you go about getting an exact reproduction of a symphony orchestra as played back in the same hall it was recorded? The oldest bogeyman of recording arises in all his majesty—double liveness.

If you make a good recording of the orchestra according to normal principles, with mikes placed so as to pick up enough liveness to balance the orchestra's own sound as heard in the average home living room, which is no concert hall, then what happens if you play it back on the spot? The audience hears a recording of the vast orchestra in the vast spaces of Constitution Hall, reverberating a second time in the vast spaces of Constitution Hall. The original sound? Hardly.

What if you want an exact reproduction of the orchestra, an Absolute recording where the loudspeakers replace the instruments, as nearly as possible? You must face the problem of liveness, one way or another. Ideally, your recording should have no liveness in it at all, so that when played in the hall it would take on the normal liveness of the playing space, as does the live orchestra. But how? What mike placement could do that?

None. Impossible. If the orchestra could have recorded ahead of time in a studio of the most extreme deadness, padded, the resulting tape could have been played in Constitution Hall immediately after the

# Leonard Radio "Audio Mart"

## First with the finest Hi-Fi Components



**PENTRON "DYNACORD"**  
Professional Tape Recorder

Ideal for portable use or rack mounting. . . . Conforms to NARTB Standards. Driven by slow speed hysteresis motor . . . flutter damped out in the motor. Braking time is under 3 seconds from fast forward or rewind to full stop. Employs foolproof interlocked controls. Push button control for fast forward, fast rewind and record. Head assembly contains editing device for easy marking of tape. Instantaneous emergency stop.

**SPECIFICATIONS:**

**TAPE SPEEDS:** 7 1/2 and 15 in/sec. (Equalization for speeds provided with switch conveniently located). **FREQUENCY RESPONSE:** 15 in/sec. ± 2 db, 50-15,000 cycles/sec.; 7 1/2 in/sec. ± 2 db, 50-10,000 cycles/sec. **SIGNAL-TO-NOISE RATIO:** Over 55 db peak record level to unweighted noise. **FLUTTER AND WOW:** Under 0.3% at 7 1/2 in/sec.; .2% at 15 in/sec. **STARTING TIME:** 1/10 sec. **STOPPING TIME:** at 15 in/sec. less than one second over travel. **CONTROLS:** A 3 position rotary switch providing play or edit and stop position. Push buttons for record, fast forward and fast rewind. **EMERGENCY STOP:** Muting and stopping of tape transport in event of tape breakage or run-out while in operation. **MONITORING:** Independent record and playback systems allow tape to be monitored while recording. Phone jack provided to monitor either the record input signal before or during recording, or the output signal from the playback head while recording or during playback. A-B switch incorporated so that direct comparison can be made between the original program and the recorded program. **PHYSICAL MOUNTING:** Standard 19" rack mounting. Panel space necessary: 12 1/4" for tape transport unit only. **AMPLIFIERS:** Separate record and playback.

**\$395.00 net**

**DYNACORD AMPLIFIER MODEL DP-100**

**FREQUENCY RESPONSE:** ± 2 db 50-15,000 cps at 15 in/sec.; ± 2 db 50-10,000 cps at 7 1/2 in/sec. **SIGNAL-TO-NOISE RATIO:** 55 db. **INPUT IMPEDANCE:** 50, 200, 500/600 ohms. **OUTPUT IMPEDANCE:** 50, 150, 500/600 ohms. **EQUALIZERS:** Setting for 15" and 7 1/2" per sec. **MONITORING:** From tape or input. **METERING:** 4 inch illuminated VU Meter to measure record level, playback, and erase current at the flick of a switch. **WEIGHT:** 13 pounds. **SIZE:** 19" x 6" x 10 1/4" deep. **POWER REQUIRED:** 50 watts.



**\$150.00 net**

**DYNACORD AMPLIFIER MODEL DS-10**

**FREQUENCY RESPONSE:** ± 2 db 50-15,000 cps at 15 in/sec.; ± 2 db 50-9000 cps at 7 1/2 in/sec. **INPUT IMPEDANCE:** 100,000 ohms, unbalanced. **INPUT LEVEL:** 55 db below 1 volt. **EQUALIZERS:** Settings for 15" and 7 1/2" per sec. **MONITORING:** Direct from tape, front panel phone jack. Phone jack for head-phone—front panel. **METERING:** Illuminated VU meter for recording level. **WEIGHT:** 13 pounds. **SIZE:** 19 1/2" x 6" x 10 1/4" deep. **OUTPUT LEVEL:** 1 1/2 volts at 10,000 ohms. **POWER REQUIRED:** 50 watts. **CARRYING CASES:** Price available on request.



**\$90.00 net**

**GIBSON GIRL AUTOMATIC TAPE SPLICER**

Here at last is a completely automatic tape splicer. It cuts, feeds splicing tape, and trims in one operation. Unique Gibson Girl trim prevents adhesive from splicing tape transferring to any of the delicate parts of the recorder. No more hunting for splicing tape and razor blade! No more fumbling with the ends of tape or struggling with ragged trim edges. It's all automatic with the Gibson Girl Model TS-4DLX splicer.

**\$14.50 list**

**MODEL TS-4DLX . . . . . NET \$8.70**

**MODEL TS-4: As above, without automatic splicing tape feed. . . . . NET \$6.79**



**LEONARD RADIO, INC.**  
AUDIO MART 69 Corlandt St., New York 7, N.Y. CORlandt 7-0315

New! "Audio Reference Guide" 160 page book all about HI-FI  
Write for your free copy today. A-Z  
Mail and phone orders filled, 24 hour service . . . 25% deposit, balance C. O. D.

actual orchestra's performance with quite extraordinary realism. No liveness in the recording, the normal, single, hall liveness added impartially both to the live version by actual instruments and to the recorded version, done ahead in the studio.

But this would have spoiled the intended drama, and nobody could ever have got it explained, anyhow!

A very close placement of many mikes, set up as near to each instrument or group of instruments as possible, would have produced tape with relatively little liveness—a monstrosity that would sound perfectly horrible anywhere outside of the hall. But, played back in the hall itself, it might provide a pretty good literal replica of the orchestra, at a concert-seat listening

distance. Remember that a close-up recording, if played at normal volume, isn't close-up if you listen to it a hundred feet away. The "original" sound-source is so close to itself as to be zero distance from itself, if you care to think of it that way; a mike, to reproduce that sound, can only get within inches of it.

\* \* \* \*

Well, I doubt if all this bothered the Soundorama audience very much. What's a bit of extra liveness here and there in a big concert hall like the home of the D.A.R.? I only note that by very special arrangement the tapes that were made had union blessings—on the condition that they be erased immediately after use.

## "NEW B-J ARM MAKES ALL OTHERS OBSOLETE"\*

Only the B-J arm holds the stylus parallel to the groove from the beginning to the end of the record.



Precision made by British craftsmen. It's the perfect pickup arm for the most discriminating Hi-Fidelity enthusiast.

**SOLVES TRACKING ERROR** because stylus is held parallel accurately within 1 degree in all grooves of a 12 inch. **NO DISTORTION DUE TO TRACKING ERROR!**

**LESS STYLUS WEAR** because, from beginning to end, the stylus is properly seated in the groove.

**LESS RECORD WEAR** because stylus is held in constant parallel position.

**LESS SURFACE NOISE** because stylus tracks with less friction from start to finish.

**LESS RUMBLE** because stylus is accurately seated at all radii of the sound track.

**LESS PICKUP ARM DISTORTION** because natural tone-arm resonances are eliminated . . . the B-J twin arms cancel out each other.

**B-J LETS YOU** take full advantage of the longer frequency response of modern records and pickups.

**B-J WILL ACCOMMODATE** most standard pickup cartridges.

**B-J IS EASY TO INSTALL.** Do it yourself! Full instructions. Will work on any turntable except automatic.

**ORDER DIRECT:** Dept. "A"

**HI-FIDELITY DISTRIBUTORS, INC.**

420 Madison Ave., New York 17, N. Y.

\*Gramophone, London

Dealers and Distributors: Apply to  
**BRITISH ELECTRONIC SALES CO., INC.**, 23-03 45th Road, Long Island City 1, N. Y.

**\$22.50**

postpaid  
anywhere in  
U.S.A. or Canada

COMPLETE  
WITH  
NEW SHELL

## SOUND SYSTEM

(from page 19)

The amplifier and loudspeaker which come with the projector certainly do not enhance the quality. So we have arranged to bypass the projector sound output stages and feed the sound through our own system with considerable improvement of intelligibility.

Figure 7 is a schematic of the circuits in the main amplifier. Each portion of this amplifier was chosen to suit our needs and to obtain top quality in conjunction with the rest of the system. Its over-all characteristic with neutral setting of tone controls shows a gradual boost of the highs in the middle range and attenuation of lows below 100 cps.

As we mentioned earlier, low frequencies are accentuated by reflection

That's a good one. Any tape that was made in Constitution Hall for optimum play back in the same hall would automatically be quite worthless for any commercial purpose! Still, you never know. Some enterprising soul might smell a good thing and bring out a Recording of a Recording of a live symphony—a sensational First!

My congrats to the several promoters of Soundorama for tackling a very complicated experiment with unexampled bravery in the face of horrid danger, before a vast and vital audience out to see what hi-fi was really like, with the Real Thing, the orchestra itself, right there on hand for AB comparison. And all with practically no opportunity to experiment in advance to see how the job could be done successfully. Phew! Messrs. Fisher, Berlant, and representatives of Jensen and WGMS may now send us each a strand of their nice new gray hair.

P. S. Not quite a First, at that. Did anybody hear the famous demonstration at Tanglewood, years back, when the famous "Berkshire" phonograph was introduced to the press, in the Tanglewood music shed? I did. The Boston Symphony in all its majesty, complete with Serge Koussevitsky, started an overture or something, I forget just what; I must have been sleepy, for of a sudden I noticed, to my surprise, that the conductor hadn't been conducting for some time. Neither was the orchestra playing. Instead, it was the "Berkshire," suspended up in the air with floodlights on it, or rather a battery of X dozen RCA LCIA speakers operating from the Berkshire's pickup. A special disc record had been recorded ahead of time, and was most ingeniously synchronized to match the orchestra itself.

An excellent demonstration and I never did figure out just when the transition was made. No tape, in those days either; it was all disc. To be sure, the point was slightly forced—that the "Berkshire" could sound just like the Real Thing. Not without the aid of a battery of extra speakers and amplifiers and dozens of technicians working for days. But I was tremendously impressed and so was everybody else. I'm sure the Soundorama did as well in Washington, D.C.

(We were there. It did. Ed).



and acoustical feedback, while the highs are usually attenuated by the electrical system and loudspeaker deficiencies. The characteristic of this amplifier serves to protect our horn driver from frequencies below its rating and overcomes any over-all treble deficiency.

The output transformer can be any good-quality unit with 6,600-ohm primary impedance for push-pull tubes and large enough to handle the plate current involved. We have used different transformers in similar circuits with equal success. It must have a 15- or 16-ohm tap in the secondary winding for matching the normal driver used on a horn.

The resistor in the feedback loop must be determined by experiment for the particular transformer used. We have found that it varies somewhere between 6,000 and 20,000 ohms. The best way to determine its value is to substitute a 50,000-ohm potentiometer and use an audio oscillator and scope for checking the response curve through the amplifier. As the resistance of the feedback loop is lowered, with a sine wave showing on the scope, a place will be reached where the scope trace breaks up into parasitic oscillations. The resistance should be raised well above this point and its amount determined to give the degree of attenuation that can be spared for this amplifier. After it is set, remove the potentiometer and replace it with a 1-watt fixed resistor.

The output stage is a variation of the Williamson with a separate source of supply for the screen grids. With a 6,600-ohm output transformer, the best scope trace was obtained with reasonably close adjustment of the plate voltage at 360 and the screen supply voltage at 275. Either 6L6's or 5881's are adequate for output tubes.

The driver is a variation of the floating paraphase inverter. For the utmost in freedom from distortion in high-quality music reproduction, one is supposed to separate the phase inverter from the driver stage. But this system is not normally handling lows that produce IM distortion. With the 6SL7 tube we have been highly pleased with the quality in the three amplifiers we have built for our church p.a. work.

#### Tone Controls

One of our most important objectives is the facility for emphasizing different portions of the sound spectrum under different conditions and for voice characteristics. In churches, clubs, and lodges, where the same people are in attendance all the time, there are people with poor hearing who want the p.a. system used all the time. Then there are those who have fine hearing and want it turned off because it sounds unnatural and distasteful to them. In restaurant banquet rooms and halls catering to miscellaneous groups, people will tolerate a p.a. system that sounds bad; but not so in our church.

So, in an endeavor to serve all concerned, we have installed a system described in an article by Basil T. Barber in *AUDIO ENGINEERING*, September 1953. The important difference between

it and other circuits is that the tone control is used in feedback circuits rather than as direct attenuation of the signal paths. This gives a continuously variable choice of transition frequencies rather than just attenuation of signal at fixed frequencies.

Both the treble and bass controls can be used to raise or lower the transition points in their range of control or can be set for fairly flat operation at their approximate center points. The use of this circuit is really gratifying to the perfectionist. Judicious use of the two controls can make wondrous correction to voice deficiencies of certain speakers.  $V_6$  in Fig. 7 is the tone control stage and  $P_6$  and  $P_7$  are the tone control potentiometers.

Again we call attention to the fact that such a tone control system can only be effective if it is teamed with a high quality loudspeaker system.

#### Preamplifier and Inputs

The phono-preamp stage for variable reluctance pickups is used very little and could normally be left out. It is one that we have found highly satisfactory for use with a GE pickup and is covered in an article by George Ellis Jones Jr., in the January 1952 *AUDIO ENGINEERING*. Like our tone control circuit, it also varies the bass transition frequency by inverse feedback.

The microphone preamplifier stage is not normally used when the preamplifier at the stage is working. It



MC-30 \$143.50

**30 watt  
AMPLIFIER**

**McIntosh**

The new McIntosh power amplifier MC-30 is unequalled for quality reproduction of high fidelity sound. The basically different, patented McIntosh circuit *guarantees* a new standard for low distortion—1/3% harmonic, 20-20,000 cycles, even at full power output! Hum and noise level—inaudible (90 db below full output). This outstanding performance assures new listening enjoyment without fatigue. Quality crafted by amplification specialists for lifetime satisfaction. There's nothing like the McIntosh. Hear it at your dealer's.

Write today for complete specifications



**McINTOSH LABORATORY, INC.**

324 WATER STREET • BINGHAMTON, NEW YORK

Export Division: 25 Warren St., New York 7, N. Y. Cable: SIMONTRICE N. Y.

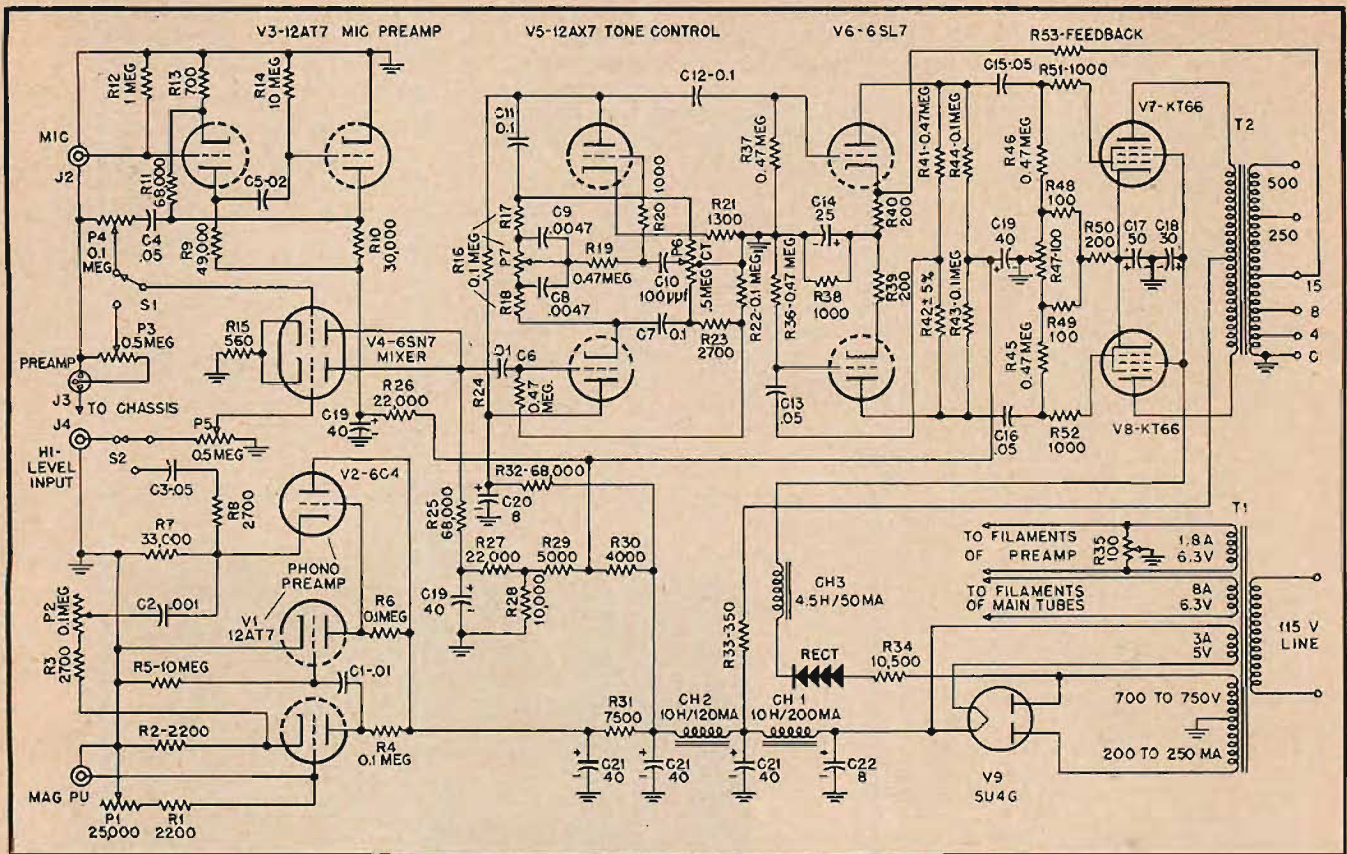

Fig. 7. Over-all schematic of the main amplifier used with the reinforcing system.



## Sound with Alpine Clarity

That is the fidelity that comes with Philips of Netherlands loudspeakers. Every note in every register, whether voice or instrument, with Alpine-air clearness. A perfection resulting from the use of a new construction — with "Ticonal" steel. The most powerful of magnet mediums that allows more compact units and outmodes awkward "woofer" and "tweeter" construction.

Model 9762 — 12" speaker with a record efficiency of 14% at 400 c/s due to use of extra powerful "Ticonal" magnet. The acoustical output and reproduction range of Hi-Fi and other equipment can be raised to a level never

before achieved! Frequency range is 40 to 20,000 c/s, 20 watts — 8 ohms. List \$94.95. Model 9750 is an 8½" version of this speaker, 10 watts — 8 ohms. List \$32.95. Model 7010 — 8½" speaker, 45 to 12,000 c/s frequency range with a special feature in a magnetic system pressed into a high precision frame to avoid misalignment of the air gap even in case of heavy shocks, 5 watts — 4 ohms. List \$16.50.

All list prices subject to the usual audiophile discounts. Available at leading jobbers or Duotone Co., Inc., Keyport, New Jersey. Write for catalogue.

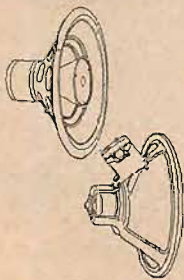

serves as a standby input for emergencies. It can be used for the portable line-transformer input from the stage mikes when that preamp fails and for break-in announcements with a mike in the projection room. Or it can be used as the regular mike input when this amplifier is hauled off somewhere else and used for a portable p.a. system.

The mixer stage is very simple and its gain was deliberately cut down as low as possible. This was found necessary because the output from the two preamplifier stages was so high that we lacked good control of volume levels in this particular amplifier.

To prevent pickup of noise and hum, every cable from the mike connection receptacles at the front edge of the stage to the stage preamp and from the preamp at the stage to the outlet box in the projection room is a 2-conductor type with either shield or armor. All shields and chassis are bonded together by shield continuity and one ground is made at the main chassis in the projection room. At other locations, the equipment and lines are kept free from piping and grounds. This is to prevent hum or noise pickup by ground loops.

The line from the stage preamp is terminated in a 3-prong Cannon XL-series plug with mating receptacle for this input in the main amplifier. This is so there can be no mixup in the connections. This plug also mates with the plug connector on the input end of the portable line transformer but its output is made through a single-contact Amphenol 75.

## ABOUT MUSIC

(from page 12)

His veiled blue eyes beneath a high and noble forehead were his most arresting features.

Furtwängler's complete musical identification with the nineteenth century made him one of the world's leading conductors in this repertoire. But his power also was his weakness. He was out of place in the sprightly rhythms of a Mozart *Serenade* or in the gossamer-like scores of Debussy and Ravel. It would have been as inconceivable for Furtwängler to conduct certain works as for Artur Schnabel to run through something like Chabrier's *Pièces Pittoresques*. But like Schnabel, Furtwängler wisely limited himself to those composers whom he best served.

Fortunately for the musical world, Furtwängler was active both in concert and on records until shortly before his death. For *His Master's Voice*, he recorded half a dozen Beethoven symphonies, the Beethoven Violin Concerto with Menuhin, and the *Emperor* Concerto with Fischer; a complete *Tristan und Isolde* and *Fidelio*; Mozart's Symphony No. 40; Brahms' First and the *Variations on a Theme by Haydn*; Schumann's *Manfred* Overture; *Death and Transfiguration* by Strauss; a Wagner concert and the *Immolation* Scene from *Die Götterdämmerung*. For London first, he brought out Brahms' Second, and the

Franck Symphony in D minor; and for Deutsche Grammophon, Schubert's Ninth and Haydn's 88th. Of these, the most outstanding disks are the *Eroica* (LHMV 1044), with a particularly moving slow movement; a spine-chilling version of *Siegfried's Funeral Music* from *Die Götterdämmerung* (LHMV 1049) (the brass never sounded as menacing); a lyrical interpretation of the Beethoven Violin Concerto (LHMV 1061) in which Menuhin never sounded better; an imaginative and impassioned rendition of the *Manfred* Overture (LHMV 1023) one that Schumann, with his preference for slower tempi, would have liked; and a broadly conceived *Tristan und Isolde* (LM 6700) which, despite a weak male lead, remains an unforgettable

experience. RCA Victor also plans to release the Furtwängler *Fidelio* in spite of the fact that one by Toscanini is already in the catalogue.

Furtwängler has often been criticized for his slow tempi, just as Toscanini has been criticized for his fast pulse. Actually, there is more than one speed at which a Beethoven Overture or a Brahms Symphony may be taken. The important thing is the inherent validity of an interpretation within reasonable tempo limitations. What Furtwängler brought to his performances was a breadth of line as magnificent as the noble flight of a large-winged bird, and a probing insight that seemed to transform the familiar into a new and stirring experience.

Unexpected peaks like this →

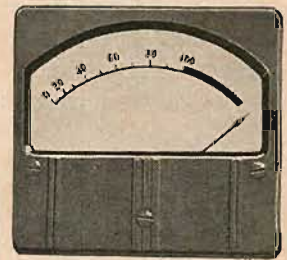

Look like this →

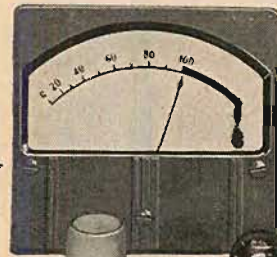

With the →



## UNI-LEVEL AMPLIFIER

HERE you have the answer to any audio engineer's prayers. The G-E Uni-Level Amplifier automatically compensates for level changes encountered between different audio sources. Its expansion-compression characteristics smooth out and increase average levels for all types of program material. You'll get higher average output. You'll save time and effort while performance is greatly improved.

USE: In TV-FM-AM Broadcasting • In Public Address Systems • In Recording Studio Applications



MAIL THE COUPON (AT RIGHT) NOW  
FOR COMPLETE SPECIFICATIONS

Progress Is Our Most Important Product

GENERAL  ELECTRIC

General Electric Co., Broadcast Equipment,  
Sec. X4425, Electronics Park, Syracuse, N. Y.  
Please send me information and detailed specs  
on the new G-E Uni-Level Amplifier.

NAME .....  
ADDRESS .....  
CITY ..... STATE .....

tuned  
to  
tomorrow



## HORIZON 20

20-WATT AMPLIFIER

### UNITY-COUPLING:

Exclusive circuit eliminates impulse distortion characteristic in conventional amplifiers. Transformer's only function is to provide impedance match to speaker.

### HARMONIC DISTORTION:

Less than .3% at rated output of 20 watts, at 25 watts the distortion is .6% or less.

### INTERMODULATION DISTORTION:

Not more than 1% at 20 watts output measured with 400 cps and 7 kc mixed 4/1.

### FREQUENCY RESPONSE:

20 cps — 20 kc  $\pm 1$  db; 10 cps — 100 kc  $\pm 1$  db.

### POWER RESPONSE AT 20 WATTS:

20 cps — 20 kc  $\pm 1.5$  db; 10 cps — 60 kc  $\pm 1$  db.

### HUM AND NOISE:

80 db below 20 watts output.

### SENSITIVITY:

1.6 volts for 20 watts output.

### OUTPUT IMPEDANCE:

8 and 16.

### INPUT IMPEDANCE:

500 k.

### OTHER FEATURES:

Input level control, rumble filter (effective below 30 cps — may be easily disconnected if preferred), plugs and wiring for use with the Horizon 5 pre-amplifier, 117 V accessory plug.

### TUBES:

12AX7, 6L6G (2), 5U4G.

**\$84<sup>95</sup>**

WRITE FOR COMPLETE SPECIFICATIONS TO DEPT. 830

**National**

NATIONAL COMPANY, INC.  
61 SHERMAN ST., MALDEN 48, MASS.

# Glossary of Tape Recording Terms for the Amateur Recording Fan

When a person engages in a new art with which he is not familiar, he is likely to hear words which have no meaning and might, therefore, just as well be in Greek or Sanskrit. This listing, for which we are indebted to MMM, should help to clarify this problem.

Note: Additional copies of this glossary in mimeographed form may be obtained free by writing Minnesota Mining and Manufacturing Co., Dept. M5-12, 900 Fauquier St., St. Paul, Minn.

**T**APE RECORDING has given new meaning to many words in the English Language. Numerous terms long used in the field of sound have become important to the tape recorder user. Here—in non-technical language—is a glossary of some of the most common tape recording terms, prepared by Minnesota Mining and Manufacturing Company\* for the tape user.

**ACETATE FILM**—The super-smooth, transparent plastic film which forms the tough backing for approximately 90 per cent of the magnetic recording tape



made in the world today. "Scotch" brand magnetic tapes Nos. 111, 120, and "Scotch" brand "Extra Play" magnetic tape No. 190 all employ acetate film backings.

**"A" WIND** (rhymes with kind)—Magnetic tape wound on the reel with the dull, oxide-coated side of the tape toward the inside. The wind almost universally used today. Recorder design determines whether "A" or "B" wind tape is required.

**AUDIBLE TONES**—Sounds with wave frequencies which the average human can hear and which range from 30 to 15,000 cycles per second (cps).

**"B" WIND**—Tape wound with oxide out. Seldom used today. Wind can be changed from "A" to "B" by putting half twist in tape and rewinding on recorder.

\*900 Fauquier Ave., St. Paul 6, Minnesota

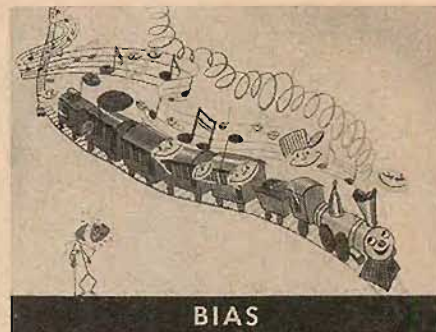

**BIAS**

**BIAS**—A high-frequency alternating current fed into the recording circuit to eliminate distortion.

**BINAURAL RECORDER**—A tape recorder which employs two separate recording channels or systems, each with its own microphone, amplifier, recording and playback heads, and earphones. Recordings using both systems are made simultaneously on a single magnetic tape on two parallel tracks which, upon playback, reproduce the original sound with depth and realism unequalled by any other recording method. Use of headphones for listening is necessary for true binaural effect.

**BULK ERASER**—A 110-volt a.c. device used to erase an entire reel of magnetic tape at once without running it through a recorder. It uses a strong magnetic field which neutralizes the magnetic patterns on the tape.

**CAPSTAN**—The spindle or shaft—often the motor shaft itself—which rotates against the tape pulling it along at a constant speed on recording and playback.

**CYCLES PER SECOND**—The unit for measuring the frequency, or "pitch," of any sound. Abbreviated *cps*.

**DECIBEL**—Abbreviated *db*, it is a rel-



**DECIBELS**

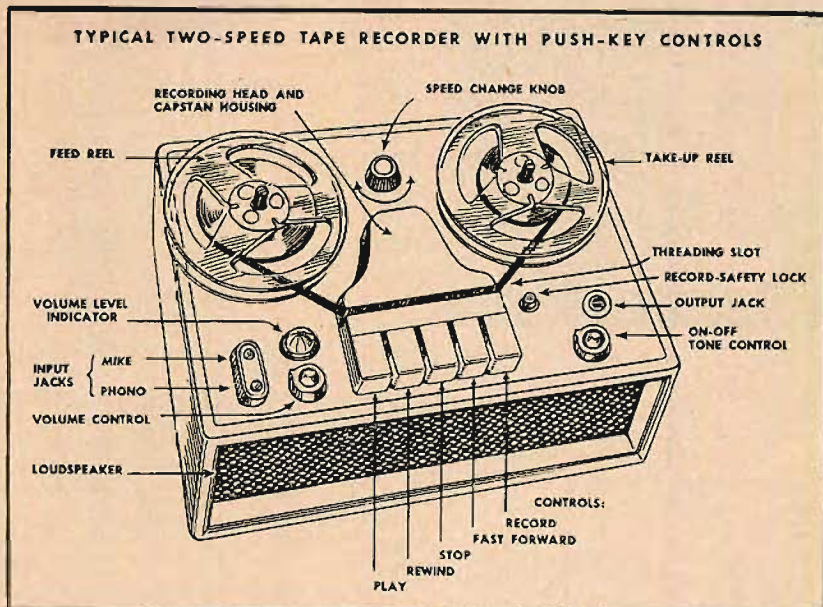

ative measure of sound intensity or "volume." It expresses the ratio of one sound intensity to another. One db is the smallest change in sound volume that the trained human ear can detect.

**DISTORTION**—Any difference between the original sound and that reproduced by a recording machine. Distortion takes on many forms, and although it can never be completely eliminated, it can be reduced to a minimum in a good recording and reproducing system. Tape offers the maximum potential in distortion-free recording.

**DUAL-TRACK RECORDER**—Usually a tape recorder with a recording head that covers half of the tape width, making it possible to record one track on the tape, then turn the reels over and record a second track in the opposite direction. Sometimes called a half-track recorder.

**DUPE**—Sometimes called a "dub" or "dubbing." A copy of a tape recording made by recording on one machine what another machine is playing. Tape recordings are easy to duplicate simply by re-recording and there is a minimum loss in quality from the original to the copy.

**DYNAMIC RANGE**—The ratio between the softest and loudest sounds a tape recorder or other device can reproduce, without undesirable distortion. Usually measured in db.

**EDITING**—Selecting certain sections of a tape recording, or of a number of different tape recordings, then splicing

them together in the desired sequence. Magnetic tape is unsurpassed for editing purposes, since it can be easily cut and spliced.

**ERASURE**—Neutralizing the magnetic pattern on tape by placing it in a strong, magnetic field, thereby removing the recorded sound from the tape. An "erase" head on the tape recorder does this automatically to any sound previously recorded on the tape just before the tape reaches the "record" head. A permanent magnet can also be used to erase magnetic tape.

**EQUALIZATION**—Either boosting or decreasing the intensity of the low, middle, or high tones of a recording during recording or playback or both. This compensation is made automatically by the recorder and serves to correct any deficiencies in the recording system and to increase the signal-to-noise ratio.

**FLAT RESPONSE**—The ability of a sound system to reproduce all tones—low and high—in their proper proportion. A high-fidelity sound system might be specified as having an essentially flat response, plus or minus one db, from 30 to 15,000 cps.

**FLUTTER**—Very short, rapid variations in tape speed causing similar variations in sound volume and pitch, not present in the original sound. A form of distortion.

**FREQUENCY RANGE**—The range between the highest- and lowest-pitched sounds which a tape recorder or other

**tuned  
to  
tomorrow**



## HORIZON 10

10-WATT AMPLIFIER/PREAMP

### UNITY COUPLING:

Exclusive circuit eliminates impulse distortion characteristic of conventional amplifiers. Transformer's only function is to provide impedance match to speaker.

### DISTORTION:

Less than .5% harmonic distortion at rated output of 10 W. Not more than 2% intermodulation at 10 W output measured with 400 cps and 7 kc mixed 4:1.

### FREQUENCY RESPONSE:

20 cps — 20 kc  $\pm 1$  db on the high level inputs.

### POWER RESPONSE:

20 cps — 20 kc  $\pm 2$  db on the high level inputs.

### HUM AND NOISE LEVEL:

High level input: Better than 70 db below full output. Phono input: Better than 50 db below full output.

### OUTPUT IMPEDANCE:

8 and 16 ohms.

### CONTROLS:

Five position input selector-record equalizer switch.

Position	Input
1.	High level-Tape
2.	High level-Tuner
3.	Phono R.I.A.A.
4.	Phono A.E.S.
5.	Phono Foreign

### LOUDNESS CONTROL:

Volume control with built-in loudness compensation.

### TREBLE CONTROL:

1 db boost and 10 db cut at 10 kc.

### BASS CONTROL:

(includes Power ON-OFF switch). Provides 15 db boost at 30 cps.

### SENSITIVITY:

Inputs Tape and TV —.5 volts for 10 watts.

High level phono input — 30 mv } For 10  
Low level phono input — 10 mv } watts

### TUBES:

12AX7, 6V6G (2), 5Y3GT.

**\$79<sup>95</sup>**

WRITE FOR COMPLETE SPECIFICATIONS TO DEPT. 830

**National**

NATIONAL COMPANY, INC.  
61 SHERMAN ST., MALDEN 48, MASS.

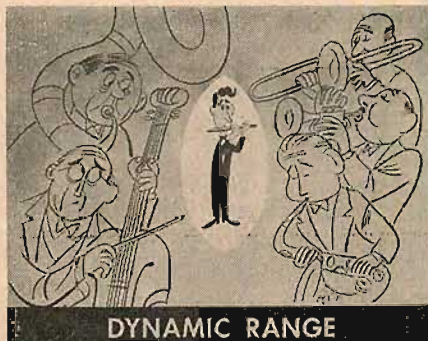
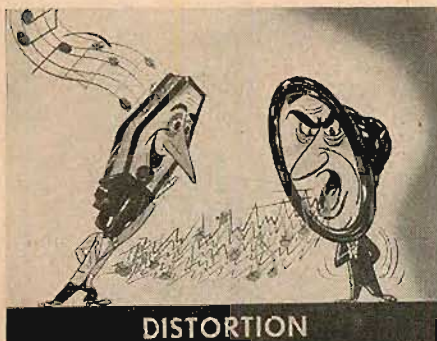

tuned  
to  
tomorrow

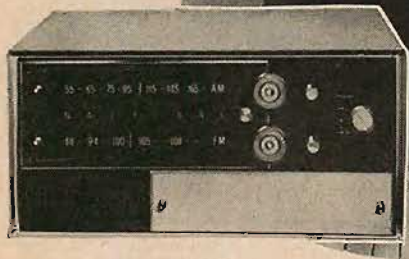

## HORIZON *Criterion*

AM-FM TUNER

### FM "MUTAMATIC" TUNING

Exclusive circuit eliminates inter-station hiss and noise present in other FM TUNERS. Desired station locks-in automatically. Fine tuning is unnecessary.

### FM SECTION

#### Sensitivity:

.5 uv for 20 db quieting. Capture ratio: rejects interfering signals up to 80% as strong as desired signal. No distortion from reflected ghosts.

#### Image rejection:

Better than 60 db, I.F. pass band is flat within  $\pm 1$  db over band of 200 kc. Audio distortion: less than 0.5% for all levels of modulation.

#### Output:

Cathode follower output. Hum & Noise level 60 db below audio signal. Full A.G.C. maintains I.F. band pass regardless of input signal level. Instantaneous limiters provide lowest impulse noise of any tuner.

Selectivity provides complete adjacent channel rejection.

### AM SECTION

#### Sensitivity:

Sensitivity: 10 uv at antenna terminals for signal-to-noise ratio of 10 db. Image ratio: better than 60 db. I.F. Pass band flat within  $\pm 1$  db over a 14.5 kc range.

### BINAURAL OPERATION

Individual tuning condensers, volume controls and output jacks for simultaneous operation. FM free of AM signal up to 100 times the FM signal input. AM free of FM signal up to 100 times AM signal input.

\$169<sup>95</sup>

WRITE FOR COMPLETE SPECIFICATIONS TO DEPT. 830

**National**

NATIONAL COMPANY, INC.  
61 SHERMAN ST., MALDEN 48, MASS.



sound system can reproduce at a useable output, or volume, level.

**FREQUENCY RESPONSE**—The output level of a recorder or sound system over a given range of frequencies. A more specific term than "frequency range." Usually in the form of a curve plotted on a chart.

**GAIN**—The ratio between the input level and output level of a piece of sound equipment. Gain is increased by means of an amplifier.

**GAP**—The tiny distance between the poles of the recording head, measured in mils. The head gap of home recorders may range from 1 mil down to  $\frac{1}{4}$  mil. The smaller the gap, the higher the frequency range of the tape recorder can be.

**HEAD**—The ring-shaped electromagnet across which the tape is drawn, and which magnetizes the iron oxide-coated tape in a series of patterns. Most tape recorders employ a combination recording-playback head and also an erase head. Some professional machines also employ a monitor head for listening to the recorded sound a split second after it has been put on the tape.

**INDEX COUNTER**—An odometer type counter which makes it possible to note the location of any particular selection of a tape, thereby making it easier to find. Many late model tape recorders feature built-in index counters.

**INPUT**—An electrical voltage fed into an amplifier.

**LEADER AND TIMING TAPE**—Special, tough, non-magnetic tape which can be spliced to either end of a tape to prevent damage or breaking off of the magnetic tape ends and possible loss of part of the recorded material. White in color, it features a one-inch plaid marker every 15 inches ("Scotch" brand leader and timing tape No. 43). Used as a timing tape, therefore, it can be spliced between musical selections on a tape providing a pause of a given number of seconds, depending on the tape speed.

**LEVEL INDICATOR**—A device on the tape recorder to indicate the level at which the recording is being made, and which serves as a warning against under-recording or over-recording. It may be a neon bulb, a "magic eye," or a VU meter.

**MAGNETIC TAPE**—A high-quality plastic or paper tape which has been precision-coated by the manufacturer with a layer of magnetizable iron-oxide particles. The result is a recording medium that is subject to virtually no wear, can be erased and re-used, and offers the

highest fidelity of reproduction possible today.

**MOTOR BOARD**—Also called tape transport mechanism. The platform, or assembly, of a tape recorder on which the motor (or motors), the reels, the heads and the controls are mounted. It includes those parts of the recorder other than the amplifier, preamplifier, loudspeaker, and case.

**OUTPUT**—An electrical voltage coming from an amplifier and normally fed into a loudspeaker.

**OXIDE**—Microscopically small particles of ferric oxide dispersed in a liquid binder and coated on a tape backing. Red oxide used on "Scotch" No. 111 magnetic tape is most common, although "Scotch" No. 120 "High Output" magnetic tape employs a dark green oxide. These oxides are magnetically "hard"—that is, once magnetized, they remain magnetized permanently, unless they are demagnetized by exposure to a strong magnetic field.

**PATCH CORD**—Sometimes called "attachment cord." A short cord, or cable, with a plug on either end (or with a pair of clips on one end) for conveniently connecting two pieces of sound equipment such as a phonograph and tape recorder, an amplifier and speaker, etc. Not used for 110-volt current.

**POLYESTER FILM**—Plastic film backing for magnetic tape used for special purposes where strength and resistance to humidity change are important. "Scotch" magnetic tapes Nos. 111AM and 120AM employ polyester film backings.

**POWER AMPLIFIER**—An amplifier designed to operate a loudspeaker.

**POWER CORD**—Cord for connecting the tape recorder to 110-volt a.c. current.

**PREAMPLIFIER**—An amplifier that raises extremely weak signal levels such as those from a microphone, magnetic playback head, or a phonograph pickup, to a level useable by the power amplifier. Some tape recorders combine the preamp and the power amplifier. Others—especially the tape recorders designed for use in high-fidelity music systems—may feature a separate preamplifier. In such cases, the preamp includes an equalization circuit. In addition, the bias oscillator (necessary to record on tape) is often mounted in a unit with the preamp.

**PRESSURE PADS**—Felt pads mounted on spring-brass arms which hold the magnetic tape in close contact with the heads on some machines.

**PRESSURE ROLLER**—Also called "capstan idler" or "puck." A rubber-tired

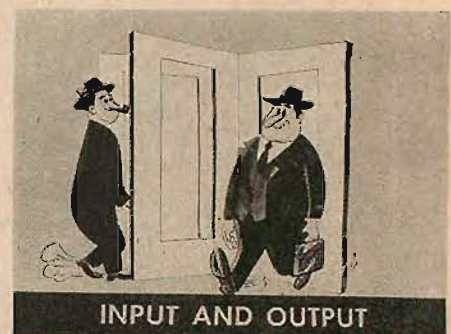

roller which holds the magnetic tape tight against the capstan by means of spring pressure to insure constant tape speed and prevent slippage.

**PRINT THROUGH**—Transfer of the magnetic field from layer to layer of tape on the reel. Virtually non-existent in high-quality magnetic tape today.

**RAW TAPE**—A term sometimes used to describe tape that has not been recorded. Also called "virgin" tape.

**RECORDED TAPE**—A recording on tape that is commercially available. Also called a "pre-recorded" tape, or—in the case of music—"music on tape." Sometimes, however, any tape that has been recorded—whether commercially available or not—is called a recorded tape.

**RECORDING NOISE**—Noise induced by the amplifier and other components of the recorder. High-quality magnetic tape itself is inherently noise-free.

**SELF-POWERED RECORDER**—Tape recorder containing its own power supply, either a combination of wet and dry cells to power the unit, or dry cells in conjunction with a spring-driven motor.

**SIGNAL-TO-NOISE RATIO**—The ratio between the loudest, undistorted tone recorded and reproduced by a recorder and the noise induced by the recording system itself. Normally measured in db.

**SINGLE-TRACK RECORDER**—A tape recorder which records only one track on the tape. Usually a full-track recording head is used which covers the full width of the 1/4-inch tape although some machines use a narrower, half-track recording head which records a single track down the middle of the tape. Output of a full-track recording is theoretically double that of a half-track recording, although actually the output is only slightly greater because of improved half-track head design.

**SPLICING TAPE**—A special, pressure-sensitive, non-magnetic tape used for splicing magnetic tape. Its "hard" adhesive will not ooze and consequently will not gum up the recording head, or cause adjacent layers of tape on the reel to stick together. ("Scotch" splicing tape No. 41 is an example. Cellophane tape should never be used.)

**TAPE GUIDES**—Grooved pins of non-magnetic material mounted at either side of the recording head assembly to position the magnetic tape on the head as it is being recorded or played.

**TAPE LOOP**—A length of magnetic tape with the ends joined together to form an endless loop. Used either on standard recorder, special "message re-



peater" type units, or in conjunction with a cartridge device, it makes it possible to play back a recorded message repetitively without rewinding the tape.

**TAPE SPEED**—Speed at which tape moves past the recording head. Standard tape speeds for home use are 3 3/4 inches per second (abbreviated *ips*) and 7 1/2 *ips*. Faster speeds are 15 *ips* and 30 *ips*. Slower speeds sometimes used are 1 7/8 *ips* and 15/16 *ips*. Faster speed makes possible improved high-frequency response, while slower speed means greater tape economy. If a tape is recorded at 3 3/4 *ips*, then played back at 7 1/2 *ips*, all sounds will be raised one octave in pitch. Cutting the speed in half lowers a tone one octave.

**TELEPHONE PICKUP**—Type of induction coil device which slips over a telephone receiver, or upon which entire telephone may rest, used to pick up both voices during a telephone conversation for recording on tape.

**THREADING SLOT**—Slot in recording head assembly cover-plate into which tape is slipped in threading up the reels for use of the recorder.

**TONE CONTROL**—Control knob on tape recorder amplifier used to vary bass and treble response to achieve most desirable balance of tone.

**VOLUME**—An acoustic—rather than electrical—measurement, which refers to the pressure of the sound waves in terms of dynes per square centimeter. The louder the sound, the greater the pressure. Most technicians prefer to talk in terms of decibels.

**VTR**—Video tape recording. Recording and reproducing television picture-tube signals on standard—but highest quality—magnetic tape ("Scotch" brand Instrumentation tape No. 109). It is extremely difficult to design a tape recorder capable of handling wide frequency range up to 4 million cycles per second. Usually several magnetic tracks are recorded side by side on a 1/2-inch tape at a considerably higher speed than used in home recording, each track recording a certain range of frequencies. Improved quality and lower operating cost are expected to enable it to replace movie film for television use.

**VU METER**—A "volume unit" meter which indicates the relative levels of the various sounds being recorded by measuring the electrical voltages.

Wow—Slow variations in tape speed causing similar variations in sound volume and pitch not present in the original sound. A form of distortion.

tuned  
to  
tomorrow



HORIZON 5

PLUG-IN PREAMP/CONTROL

**CONTROLS:**

Input Selector Record equalizer switch. Permits selection of any one of 3 high level input sources such as TV, tape and phonograph. The remaining 7 positions of this control compensate for all recording characteristics.

**BASS TONE CONTROL:**

Control range is from +25 db to -15 db at 30 cps. Flat position is accurate to 1° (one degree).

**TREBLE TONE CONTROL:**

Control range is from +15 db to -25 db at 10 kc. Flat position is accurate to within 1°.

**LOUDNESS VOLUME CONTROL**

**LOUDNESS-ON-OFF SWITCH:**

Loudness compensation to volume control may be switched off by pushing switch in toward panel.

Three source adjustment controls accessible are:

1. TV level set
2. Tape level set
3. Phonograph sensitivity switch.

**FREQUENCY RESPONSE:**

In flat position, frequency response measured from TV input is 20 cps - 20 kc ±.25 db and 20 cps - 100 kc ±1 db.

**HARMONIC DISTORTION:**

Less than .2% at 1.5 volts out, less than .6% at 10 volts out.

**INTERMODULATION DISTORTION:**

Less than .3% at 1.5 volts out, less than 1.5% at 10 volts out (at 400 cps and 7 kc mixed 4/1).

**HUM AND NOISE:**

70 db below 1.5 volts on high level inputs, 50 db below 1.5 volts on the 10 mv phonograph input.

**OUTPUT IMPEDANCE:**

Approximately 3000 ohms accommodates up to 50 ft. of cable between preamplifier and amplifier.

**TUBES:**

Two 12AX7's.

\$49.95

WRITE FOR COMPLETE SPECIFICATIONS TO DEPT. 830

**National**

NATIONAL COMPANY, INC.  
61 SHERMAN ST., MALDEN 48, MASS.





**Centralab's**  
**Junior COMPENTROL®**

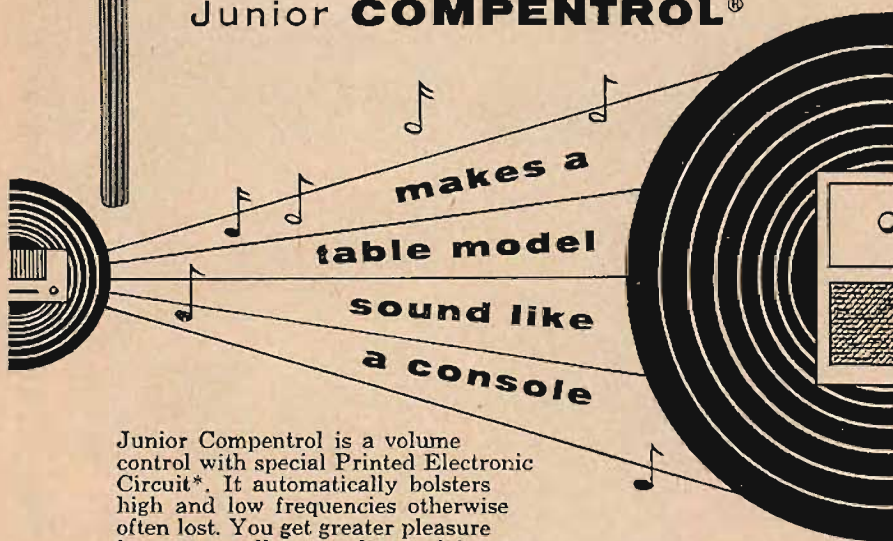

Junior Compentrol is a volume control with special Printed Electronic Circuit\*. It automatically bolsters high and low frequencies otherwise often lost. You get greater pleasure from your radio set, audio amplifier, or phono combination. Ask your Centralab distributor — or service man. Write Centralab, Dept. 933B, Milwaukee 1, Wisconsin for Compentrol booklet.

1/2 or 1 Meg.,  
less switch -- \$2.50 net  
1/2 or 1 Meg.,  
with switch -- \$3.00 net

**Centralab**

\*Trademark

B-255

*Nearly everybody reads the*  
**audio anthology**  
and  
**the 2nd audio anthology**

The original audio anthology is still being ordered by people who have worn out their first copy or who have just learned about the book. Contains reprints of 37 articles which appeared in AUDIO ENGINEERING from May 1947 through December 1949. An invaluable reference work on audio in the home.

the 2nd audio anthology continues from where the first left off and contains reprints of articles from January 1950 through July 1952. In both books the articles were brought up to date, corrected where necessary, and assembled by subject. the 2nd a may still be had with board cover.

CUT OUT — MAIL TODAY

Book Division, Dept. 3V,  
Radio Magazines, Inc.,  
P. O. Box 629, Mineola, N. Y.

Sirs: Enclosed is  check  money order for \$..... Please send me  
..... copies of audio anthology (paper cover) @ \$2.00 each  
..... copies of the 2nd audio anthology (paper cover) @ \$2.00 each  
..... copies of the 2nd audio anthology (board cover) @ \$3.00 each

Name (please print) .....

Address .....

City ..... Zone ..... State .....

**AUDIO TECHNIQUES**

(from page 27)

number of amplifiers necessary to handle remotes is reduced. It is no longer necessary to have an amplifier tied up for a show using it perhaps 5 to 15 minutes a day, so it can be freed for other uses in the field. In the original setup, the mike impedance was 50 ohms and the receiving impedance was 200 ohms. This, in addition to cutting down the crosstalk, made the line self-equalizing to a small degree. The maximum distance tried so far has been seven miles, part of which was in open country.

**A Universal Microphone Input System**

The equipment at small stations may be, sometimes, a motley assortment of microphones and amplifiers. The range of inputs runs from balanced, low impedance, to unbalanced, high-impedance. Microphones, each originally intended to be used with just one piece of equipment, can have the same variance of circuitry. To promote efficient operation with nontechnical personnel who may have to use it, a system may be needed to allow any microphone to be used with any amplifier.

All cables are fitted with standard three-prong plugs, and inputs are standardized on the amplifiers as indicated in Fig. 2. In the case of the unbalanced input, one of the wires from a balanced cable is shorted to ground at the plug on the amplifier. This will complete the circuit from the microphone. Conversely, in the case of an unbalanced mike running into a balanced input, one of the cable wires is shorted to ground at the plug on the mike, thus completing the input circuit. In order for the unbalanced mike to run into the unbalanced input, it was necessary for the same set of pins to be shorted, that is, for the same wire in the cable to be shorted to ground at both ends. Otherwise the signal will be shorted out at one end or the other. It is necessary, also, for the extension cords to have the proper polarity on the plugs at each end.

The only thing that dictates which wire should be shorted to ground in the station where this system was devised was a remote amplifier with a three-position mixer. This had an unbalanced input using ladder-type faders, and the common wire was grounded. Thus, all plugs were made to correspond to this type of wiring. It is usual, however, to place ground on pin 1, as shown.

The possible combinations now for this system are: low-impedance (balanced or unbalanced) to low-impedance (balanced or unbalanced), and low-impedance (balanced or unbalanced) to high-impedance (unbalanced). In the latter case, the microphone was run directly to the grid. There is no loss in quality this way, and the loss in gain



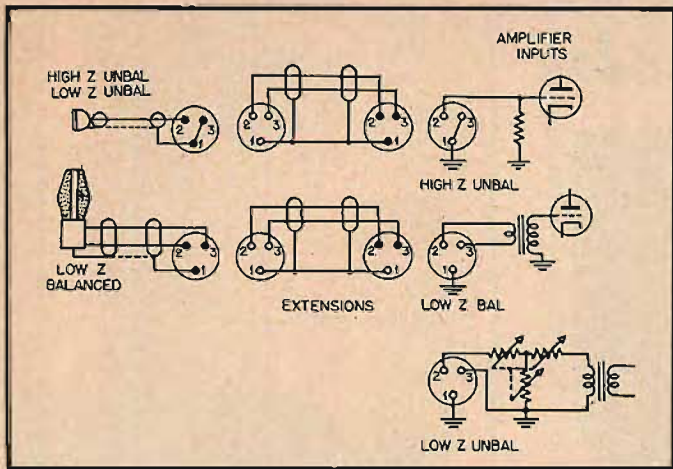

Fig. 2. Connections for microphones and amplifiers.

can usually be compensated for by the reserve gain present in most amplifiers. High-impedance mikes can be used with this system also, and a series of adapters is available for use when needed; however these are mostly for emergency. With the setup described, no adapters are necessary. With all combinations, except high impedance to high impedance, the extensions may be used without adapters or special treatment of

any kind. The only circuit changes are made right at the plugs of the units involved. Only one precaution is necessary. When using the unbalanced-to-balanced combination, the input transformer must not have a grounded primary center tap. This will short out half the primary, and in most cases set up hum and introduce other types of interference. The level will also be reduced.

## SCALING—AN AID IN CIRCUIT ANALYSIS

(from page 26)

$10^{12}$ , making  $C' = 30$ . This is equivalent to choosing  $c$  as  $10^{-8}$ . The upper half-power frequency is given by

$$\omega' = \frac{1}{R_{eq}'C'} = \frac{1}{4.5 \times 30} = .0074$$

$$\omega = \frac{\omega'}{c} = .0074 \times 10^{-8} = 740,000 \text{ rad./sec.}$$

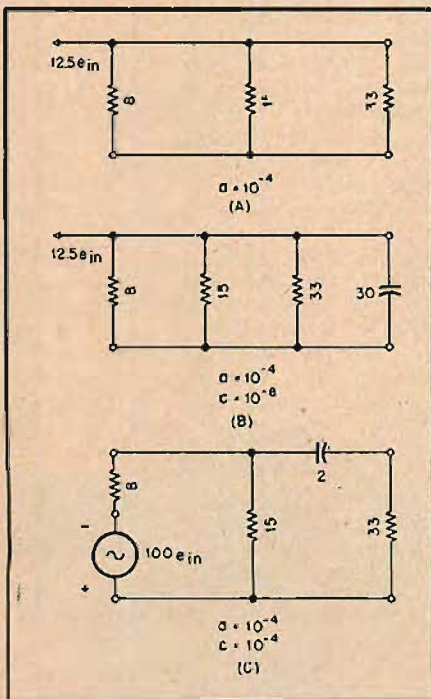

Fig. 2. Medium-, high-, and low-frequency equivalent circuits at (a), (b), and (c), with scaled values.

Because of the extreme range of capacitance values, and to more fully illustrate the method, the scaling has been changed in the low-frequency circuit. While  $a$  remains as  $10^{-4}$ ,  $1/ac$  equals  $10^8$ , or  $c$  is  $10^{-4}$ . This places the coupling capacitor at a convenient value of 2. If we combine  $r_p$  and  $R_L$  in parallel, giving 5.2 ohms, and add  $R_D$  to give 38.2 ohms, we find the lower half-power frequency as

$$\omega' = \frac{1}{R_{eq}'C'} = \frac{1}{38.5 \times 2} = .013$$

$$\omega = \frac{\omega'}{c} = .013 \times 10^4 = 130 \text{ rad./sec.}$$

This problem does little more than illustrate the procedure. The simplification is most apparent in more formidable situations. The time spent investigating and practicing scaling is soon repaid. Once the technique is acquired it lightens the mathematical burden and helps to make circuit analysis a more pleasant task.

TABLE I

QUANTITY TO BE SCALED	SCALING FACTOR	RESULTING IDENTITY*
Z	a	$Z' = aZ$
I	b	$I' = bI$
$\omega$	c	$\omega' = c\omega$
L	$a/c$	$L' = a/c L$
C	$1/ac$	$C' = 1/ac C$
E	$ab$	$E' = ab E$

\* Primed Factors indicate adjusted values.

NOTHING LIKE THIS  
IN BASS BEFORE!

## University WOOFERS



MODEL C8W

8"

LOW FREQUENCY  
REPRODUCER

Ideal for assembling a compact, limited space, high quality system . . . perfect too, as mid-range unit in low cost three-way system. Can also be used in multiples as expanding woofer. Eight ohms impedance, 25 watts power capacity.



MODEL C12W

12"

ADJUSTABLE  
RESPONSE  
WOOFER

Contains exclusive built-in facilities for limiting high end response to 700, 2000 or 5000 cycles, thus suiting crossover requirements of most tweeters. Overall response 40-6000 cycles. Handles 30 watts, impedance 8 ohms.



MODEL C15W

15"

DUAL  
IMPEDANCE RANGE  
SUPER WOOFER

Acme of attainable perfection in the specific reproduction of low frequencies. Two spiders for positive piston action. Greatest axial voice coil depth and excursion—Six lb. Alnico 5 magnet. Die-cast girder construction for lifetime trouble-free operation. Adjustable voice coil permits match to 4-8 ohms and 10-16 ohms. Defies obsolescence. For 50 watt systems.

For descriptive literature write desk 51

Another engineering achievement of

University  
LOUDSPEAKERS, INC.



80 SOUTH KENSICO AVENUE, WHITE PLAINS, N. Y.  
Ask For Progressive Speaker Expansion

# Square Wave Generator

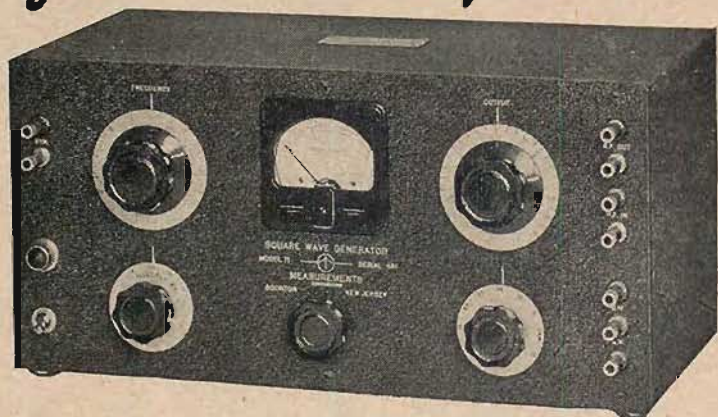

## MODEL 71

### SPECIFICATIONS

**FREQUENCY RANGE:** 5 to 100,000 cycles.  
**WAVE SHAPE:** Rise time less than 0.2 microseconds with negligible overshoot.  
**OUTPUT VOLTAGE:** Step attenuator giving 75, 50, 25, 15, 10, 5 peak volts fixed and 0 to 2.5 volts continuously variable.  
**SYNCHRONIZING OUTPUT:** 25 volts peak.  
**R. F. MODULATOR:** 5 volts maximum carrier input. Translation gain is approximately unity—Output impedance is 600 ohms.  
**POWER SUPPLY:** 117 volts, 50-60 cycles.  
**DIMENSIONS:** 7" high x 15" wide x 7½" deep overall.

**MANUFACTURERS OF**  
 Standard Signal Generators  
 Pulse Generators  
 FM Signal Generators  
 Square Wave Generators  
 Vacuum Tube Voltmeters  
 UHF Radio Noise & Field Strength Meters  
 L-C-R Bridges  
 Megohm Meters  
 Megacycle Meters  
 Intermodulation Meters  
 TV & FM Test Equipment

**MEASUREMENTS CORPORATION**  
 BOONTON NEW JERSEY

# Authoritative and Enlightening . . .

## AUDIO *Acknowledged the Leading Publication in the Field of Sound Reproduction*

If you are novice, hobbyist, experimenter, or engineer . . . if you are a lover of music . . . and in pursuit of sound, undistorted . . . AUDIO will be your faithful, reliable companion all the way. "What to Do" and "How to Do" will guide your every move through this thrilling experience we call Audio.

Each new issue brings New Ideas, New Slants, and Latest Developments . . . month in and month out . . . twelve times a year.

BE SURE to get your copies REGULARLY

MAIL this Coupon NOW

### AUDIO

P. O. Box 629, Mineola, N. Y.

Enclosed is  Check  Money Order for \$.....  
 Please send a copy of each new issue of AUDIO for the next  
 12 months;  24 months to:  
 Please Print

Name .....

Address .....

City ..... Zone ..... State .....

Subscription price, U.S.A., Possessions, Canada and Mexico:  
 1 year \$4.00; 2 years \$7.00, all other countries \$5.00 per year

## PILOTONE AA-420

(from page 32)

Phono equalization is in the form of a loss network between the two sections of the preamp tube, and both turnover and rolloff are separately adjustable. The switch is a dual concentric type, with the outer knob controlling the turnover and the inner knob selecting the amount of rolloff. The RIAA position is at the top, with the panel

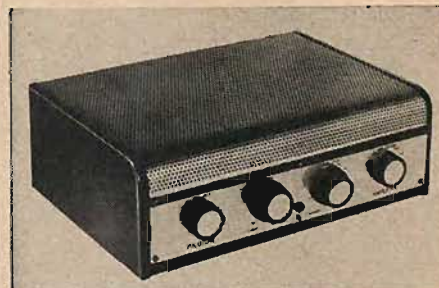

Fig. 3. External appearance of the AA-420.

designation serving for both knobs; the turnover positions progress counterclockwise through LP, AES, NAB, and 800, while the rolloff control progresses clockwise through -20, -16, -8, and 0, representing the rolloff in db at 10,000 cps. This arrangement is easy to use, since most records of recent origin will play satisfactorily on the RIAA position, and the controls can be left on this position unless some touching up is required.

The tone control section is located between the two halves of a 12AX7, and provides a relative wide "flat" section at the center, where neither end of the response is affected. Both bass and treble controls are located together, using another dual unit, with the outer knob controlling bass and the inner knob controlling the treble response.

The volume-loudness control works with a single knob, and at normal operating position provides suitable equalization for satisfactory listening. A hum balance control is provided, and is a center-tapping potentiometer across the heater winding, with all heaters being biased positively by 24 volts above ground.

Performance curves for the AA-420 are shown in Fig. 1. Note that the IM distortion is only 1 per cent at 15 watts output, so the rating is quite conservative since our preference for power output rating of an amplifier is at the 2-per cent IM point, which in this instance is 17.2 watts. Distortion is only 5 per cent at 20 watts, although there is not an ap-

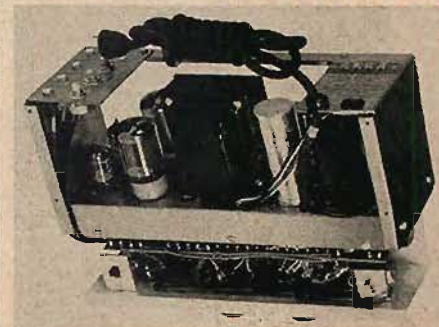
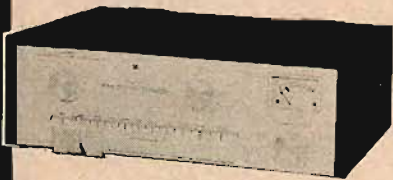

Fig. 4. Chassis view of the Pilotone AA-420.

In Stock at **ARROW**  
The Heart of Your Hi Fi  
System by H. H. Scott



H. H. Scott 310-A  
FM Broadcast Monitor Tuner

Noise and interference-free reception of even weakest stations without distortion. Wide-band circuit design. 2 mc wide-band detectors and 3 effective limiting stages make tuning entirely non-critical and drift-free. Single sweep tuning. Fine tuning control and signal meter allow precision tuning of weakest signals. Dynaural interstation noise suppressor, adjustable on front panel, eliminates annoying FM "roar" between stations. Attractively styled, the tuner is designed for the serious music lover as well as for professional broadcast applications. Sensitivity 2 microvolts with 20 db of quieting, 4 microvolts with 40 db quieting. 10 tubes. Self-powered.

Net Price . . . . . \$146.51



H. H. Scott 210-C  
Dynaural Amplifier

Here in one compact package is a complete 23 watt power amplifier and equalizer-preamplifier. Incorporates the Dynaural dynamic noise suppressor and record distortion filter. Eight position equalizer including the new RIAA-NARTB standard. Loudness control (with switch) and input selector switch for instant choice of PHONO, TUNER, TAPE or TV. Jacks are provided for simplifying tape recording. Frequency response flat from 19 cps to 35,000 cps. Harmonic distortion less than .5% at full power output. 2, 4, 8, 16 ohms.

Net Price . . . . . \$169.05

**FREE**

AUDIO EQUIPMENT  
HANDBOOK

104 pages of down-to-earth Hi-Fi information. Plus specifications and illustrations of all quality Hi-Fi equipment. Write for your FREE copy today.



Arrow Electronics

**AudioCenter**  
ALWAYS AN AUDIO FAIR  
65-A CORTLANDT ST., NEW YORK 7, N.Y.

preciable difference in output volume from 15 to 20 watts, it must be admitted.

One-watt output is reached with an input of .05 volts on RADIO, TAPE, and AUX; 5 and 24 millivolts respectively give a 1-watt output from the phono inputs.

Three output impedances are provided, 4, 8, and 16 ohms, and a convenience outlet controlled by the power switch provides for tuner or turntable.

This department wishes to compliment Pilot particularly for the completeness of the information provided on the schematics furnished in the instruction books. While not shown in Fig. 2, these schematics indicate both d.c. and signal voltages throughout the amplifier, and show the pin connections to the tubes, part numbers for switches and controls that are not available as replacement items from usual jobber sources, as well as for the transformers and filter capacitors. This information has been removed from the schematic as reproduced here in order to make the important circuitry more readable, since the reproduction is somewhat smaller than the original schematic. To do any intelligent servicing on audio equipment—as well as on radio and television sets—it is necessary that this information be at hand, and many schematics do not provide the data in so useful a form.

**Sargent-Rayment SR-808**

(from page 34)

of the control. The volume control and the loudness switch are combined in a dual-concentric unit.

The bottom section of Fig. 1 shows the effect of the tone controls with the turn-over set at 350 cps, both with and without the 50-cps cut. The treble boost differs between the two positions, although treble cut remains the same for both. The low-pass filter switch is combined in a dual-concentric unit also, with the switch selecting the cutoff frequency, as shown in the filter curves. It will be noted that these cutoffs are quite sharp—the result of a true L-C filter—and the effect is particularly useful when listening to distant AM stations, or in the case of noisy shellac records or of high distortion on any record.

The selector switch is combined with the power switch, and provides for FM with or without a.f.c., AM, and three phono positions. There are two convenience outlets—neither being controlled by the power switch—and the unit is fused. The external appearance meets the standards set by earlier S-R products, and the perforated housing matches the gold finish of the panel.

Performance on both AM and FM is excellent—FM sensitivity is just under 3 microvolts for 20 db quieting, and about 3.9 microvolts for 30 db quieting; AM sensitivity is better than 10 microvolts from a normal antenna. A 1-volt output from the unit is obtained from an input of 23 millivolts at the phono input jack, which is loaded with a 47,000-ohm resistor to accommodate Audac and GE cartridges; other load impedances can be accommodated by using an external resistor in parallel with the pickup.

THE ANSWER  
IS

University



**TWEETERS**

WHATEVER  
THE PROBLEM . . .

- Crossover
- Power Capacity
- Impedance
- Dispersion
- Response
- Cost

**NEW!**

**MODEL HF-206  
SUPER TWEETER**

High frequency response far beyond audibility. Super-efficient high output driver and horn assembly using "reciprocating flares" principle. Suitable for crossover 3500 cycles or above. Dispersion 120° x 60°, eight ohms impedance.



**MODEL  
4401  
TWEETER**

Uses "reciprocating flares" wide angle horn and baffle face compression driver. Exceptional performance at modest cost. Eight ohms impedance, suitable for crossover down to 2000 cps.



**MODEL 4402  
WIDE ANGLE DUAL TWEETER**

Electrical and acoustical characteristics make it the most versatile high frequency tweeter available. Driver can be connected for use in 4-8 and 10-16 ohm systems. Dispersion pattern variable with interconnection of drivers. High power capacity. For 2000 cycle crossover or above.



**MODEL 4408**

For wide range reproduction in moderate power systems requiring a crossover down to as low as 600 cycles. Heavy, resonant-free horn casting. Dispersion 120° x 60°. Eight ohms impedance.



**MODEL 4409**

A heavy duty version of Model 4408 to handle the full, undistorted power of 25-40 watt amplifiers in 2-way systems, and 50 watts in 3-way systems.



**MODEL  
COBREFLEX/T-30**

For use in 2- or 3-way systems when crossover as low as 350 cycles is desired. Exclusive die-cast dual wide angle horn. Eight ohms impedance. Will handle high power.

For descriptive literature, write Desk 48

Another engineering achievement of

**University**  
LOUDSPEAKERS, INC.



80 SOUTH KENSICO AVENUE WHITE PLAINS, N. Y.

Ask For Progressive Speaker Expansion

# RECOTON

## magnetic turnover cartridge

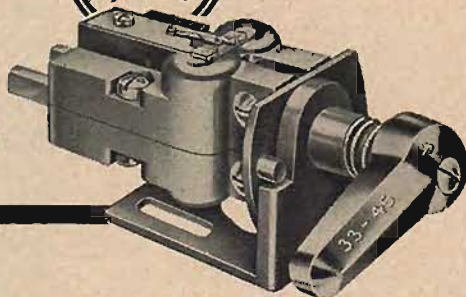

gives you unsurpassed audio performance!

Name your own standards! There is no cartridge made that excels the new RECOTON-GOLDRING.

You can enjoy all the advantages of low output while eliminating hum pickup from changer motor, transformer, etc. The answer is in Recoton's newly developed push pull coil assembly. So thrill to a new experience in listening pleasure with this amazing turnover cartridge. It gives a performance that will satisfy even the most critical hi-fi enthusiast! And its modest price of \$9.90 (including 2 sapphire styli) comes as a pleasant surprise!

- Recoton features:**
- Replaceable diamond or sapphire styli.
  - Frequency response of 20 to 16,000 cps.
  - Added shielding
  - High compliance and low mass
  - Independent safety stylus assembly
  - Minimum vertical motion
  - Simple installation

Sold by all leading hi-fi distributors. For more detailed literature and name and address of distributor nearest you, write to Dept. A.

**RECOTON CORPORATION** • 147 W. 22nd Street • New York 11, N. Y.  
Manufacturers of World Famous Diamond, Sapphire, Osmium Phono Styli

*At Last! It's off the press.*

## ELECTRONIC MUSICAL INSTRUMENTS

By Richard H. Dorf

In one big volume, you can now learn all about the intricacies of commercial electronic organs, including the Allen, Baldwin, Connsonata, Hammond, Minshall-Estey, Lowrey Organo, and others, together with many smaller instruments. Constructional details on the author's Electronorgan and the simpler Thyratone show you how to build one of these fascinating instruments for yourself. A compilation in book form of the author's articles in **Radio Electronics**, brought up to date and with many additions. Price \$7.50 (Foreign, \$8.00).

Customary discounts to dealers and distributors

**RADIO MAGAZINES, INC., Book Division,**  
P. O. Box 629, Mineola, N. Y.

Please send me ..... copies of Dorf's ELECTRONIC MUSICAL INSTRUMENTS. I enclose check  money order  for \$7.50 each (Foreign, \$8.00).

Name .....

Address .....

City ..... Zone ..... State .....

On listening tests the SR-808 was found to give excellent quality on FM; quality was about normal on the AM section with respect to frequency response, but with a minimum of distortion on high-level musical passages; the great flexibility of the tone-control section and the low- and high-pass filters permits almost any desired type of phono reproduction curve to be obtained.

## THE REALIST LINE

(from page 36)

limiter, feeding a 6AL5 discriminator. Plate supply is obtained from a selenium rectifier, using a total of 120  $\mu$ f of filter capacitance. Two output jacks are provided so that one may be connected to the power amplifier or the tone control input of a control unit, and the other may be fed to a tape recorder—a feature which is an advantage when used with older types of amplifiers which did not always include the output for a recorder.

Sensitivity is better than 5 microvolts for 30 db quieting, with adequate reception at 25 miles from New York using only 30 in. of test lead as an antenna. Sound quality is excellent, and it is the opinion of this observer that this tuner would make a welcome addition to the system where a minimum of space was available. It is probable that this tuner would fit into the phono-changer drawer in many existing cabinets, and it is certain that many people that have not heretofore enjoyed the benefits of FM reception could add this unit to any ordinary radio or radio-phonograph combination to introduce them to a new experience.

### The AM Tuner

The Realist AM tuner, Fig. 5, is of identical size with the FM tuner, and is also self powered, using a 6X4 as a recti-

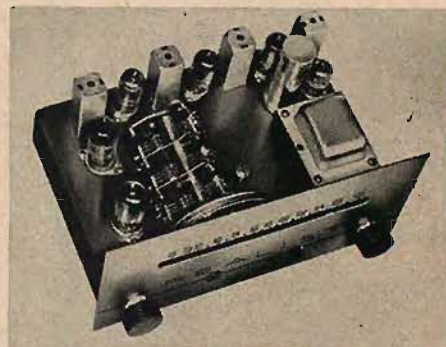

Fig. 4. The compact FM tuner in the Realist line.

fier. The circuit line-up, Fig. 6, is as follows: a 6BA6 as a tuned r.f. stage, a 6BE6 as mixer and oscillator, a second 6BA6 as i.f. amplifier, and a 6AL5 as a diode detector—one half being fed from the plate of the i.f. stage to provide the a.v.c. voltage without loading the detector diode. A radio-phono switch is provided on the front panel, as on the FM tuner, and three jacks are located on the rear apron

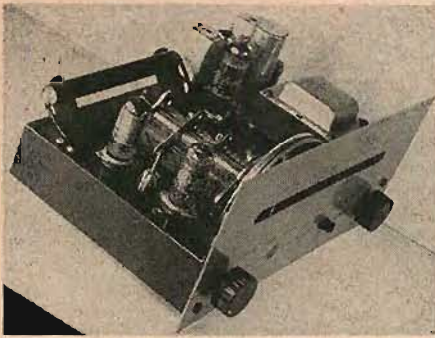

Fig. 5. The Realist AM tuner—almost identical with the FM tuner in appearance. Only the dial has been changed to avoid confusion

for phono input and for the two outputs. Being identical in appearance with the FM unit, this tuner can be mounted in a similar manner, and makes a complete radio system for stereophonic reception. With 5-microvolt sensitivity, the self-contained ferrite-cored antenna eliminates the need for outside aerials except in fringe areas, and the total power consumption is an economical 21 watts.

The entire Realist line seems to provide an answer to the need for a second system, or for inexpensive additions to an existing one without requiring elaborate cabinetry or an excessive amount of space.

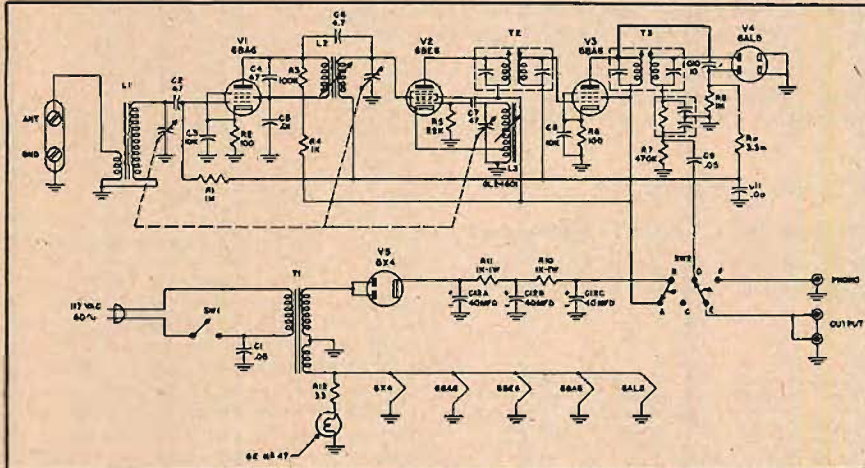

Fig. 6. Schematic of the Realist AM tuner.

## COMING EVENTS

Feb. 10-12—Southwestern region of the I.R.E. seventh annual conference and electronics show, Baker Hotel, Dallas.

Feb. 10-13—Audio Fair—Los Angeles, Alexandria Hotel, Los Angeles, Calif.

Feb. 17-18—National Conference on Transistor circuits, Irvine Auditorium, Univ. of Pennsylvania, Philadelphia, Pa. Registration, W. J. Popowski, Minneapolis-Honeywell Regulator Co., 176 W. Loudon St., Philadelphia 20, Pa.

Mar. 21-24—Radio Engineering Show and I.R.E. National Convention, Kingsbridge Army, N.Y.C.

May 16-19—Electronic Parts Distributors Show, Conrad Hilton Hotel, Chicago.

May 26-27—Electronic Components Conference, Los Angeles, Calif.

Sept. 30-Oct. 1-2—The 1955 High Fidelity Show, Palmer House, Chicago.

## LETTERS

(from page 8)

3. An article on electrostatic tweeters would be most interesting.

DAVID P. HERRON  
1923 Knox Ave., South,  
Minneapolis 5, Minn.

[Thanks for the ideas—which by publishing here may indicate to potential authors the type of material that the readers would like to see. Specifically, as to (1) we also feel that more information is necessary on this subject, although it should be determinable to the ear—by experiment. As to (2), deliveries have been slow, but as we lived with this speaker in our room at the October Audio Fair in New York, we felt it had possibilities. As to (3), one is in the "works" now. Ed.]

Thanks to Us

Sir:

We would like to thank you for publishing "A Transistor Remote Amplifier" (Sept. 1954). We suspect that WAMF is the same type of station that we are, and that their Chief Engineer is handicapped by the same lack of information that has troubled us.

WUCB, Radio Midway, is a small radio station broadcasting to those who live in three residence halls on the campus of the University of Chicago. With minor exceptions the station was constructed and is run by unpaid students.

GEORGE F. HAWK,  
WUCB, Radio Midway,  
Chicago 37, Ill.

(Thanks to you for thanking us. Ed.)

## now...Adjustable Speaker Networks by University

- To balance your system
- To suit any speaker combination
- To improve your present system

For the first time, networks and filters, so designed as to provide a wide selection of popular crossovers at various speaker impedances—So engineered as to expand, without waste or obsolescence, the sound reproduction of 2-way and 3-way systems. The built-in versatility of these units allows you to assemble systems that suit your own taste, operating conditions, and budget.



### ADJUSTABLE L/C DIVIDING NETWORKS

As 2-way network:

MODEL N-2A		MODEL N-2B	
Impedance	Crossover Selections	Impedance	Crossover Selections
8 Ohms	350, 700	8 Ohms	1250, 2500, 5000
16 Ohms	350, 700	16 Ohms	2500, 5000, 25000
4 Ohms	700	4 Ohms	2500, 5000

These units can be used singly as 6db/oct 2-way L/C networks, singly as 12db/oct L/C filters, in pairs as 12db/oct 2-way networks and in combination as 3-way networks.

### MODEL N-1 ADJUSTABLE HIGH PASS FILTER

Built-in continuously variable high frequency control. Matches 16 ohms to 1250, 2500, 5000 cycle crossover; 8 ohms to 2500, 5000, 10,000 cycles; 4 ohms to 5000 and 10,000 cycles.



### MODEL N-3 THREE-WAY CROSSOVER NETWORK

Complete with built-in continuously variable "presence" and "brilliance" controls. For 8 ohm 3-way systems using 350 and 5000 cps crossovers. Adjustable mounting arrangements.



For descriptive literature write desk 52

Another engineering achievement of

**University**  
LOUDSPEAKERS, INC.



80 SOUTH KENSICO AVENUE, WHITE PLAINS, N. Y.  
Ask For Progressive Speaker Expansion

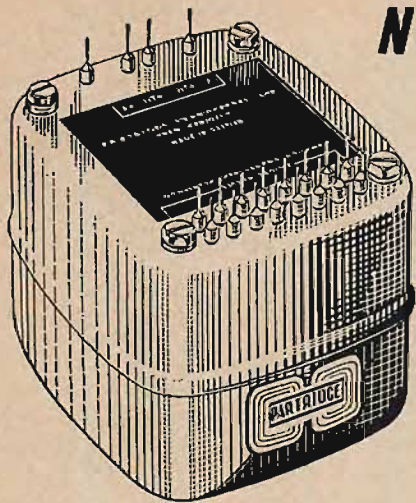

## NOW easier for you to get!

Partridge Transformers are now being sold by exclusive distributors from local stock depots throughout the U.S.A. For specifications, prices, and the name of the distributor in your area, write to:—

Partridge Transformers Ltd.,  
c/o British Electronic Sales Co., Inc.,  
23-03 45th Road, Long Island City 1, N.Y.

Among the transformers readily available is the Partridge Type CFB 'C' Core. Built to the very highest standards, the CFB reproduces full A.F. range with lowest distortion. Leakage inductance 10mH. Power up to 60W from 22c/s to 30Kc/s. Price \$43.75.

## Partridge CFB Audio Transformer

Leads the way in 'C' CORE technique!

The CFB is also available, designation T/CFB, with each half primary tapped at 43% of turns. Exactly what you want for amplifier described by Joseph Marshall, "AUDIO ENGINEERING", January 1954 and for other published circuits.

### ALSO AVAILABLE

#### TYPE W.W.F.B.

Built to the famous Williamson specification and available in a wide range of impedances. Secondary windings brought out to eight separate sections of equal impedance. Price \$27.75.

#### TYPE U.L.2.

A p.p. Transformer of 'C' Core design, specifically designed for really high quality A.F. reproducing equipment. Each half primary is brought out separately to posts and tapped at 43% of turns. Price \$26.30.



**PARTRIDGE TRANSFORMERS LTD**  
TOLWORTH · SURREY · ENGLAND

# 8 MASTERPIECES \$1.00

LONG-PLAYING (33 1/3 R.P.M.) HI-FIDELITY  
COMPLETE TO THE LAST NOTE!



**No Strings Attached!** No Need to Buy Any Other Records Ever! Full Advantages of Trial Membership

ALL 8 masterpieces for only \$1. Performed by world-famous artists. Custom-recorded on purest vinyl. Reproduced with a tonal fidelity encompassing the entire range of human hearing (50 to 15,000 cycles.) This amazing offer is made only to demonstrate superb quality of our recordings; and to show you advantages of trial membership.

**HOW CLUB OPERATES**—We advise you monthly of new releases. Those you want are sent you for FREE trial. After 5 days' listening—only the records you decide to keep are billed you at the low membership price of \$1.00 per disc (average playing time 40 min.). You save 2/3 the usual retail price! This "give-away" offer can obviously not be kept open indefinitely. MAIL COUPON NOW while supply lasts. Full money-back guarantee.

**SCHUBERT**  
"Unfinished" Symphony (No. 8)  
**BEEHOVEN**  
Ruins of Athens (March and Choir)  
**MOZART**  
Piano Concerto in E Flat  
**BACH**  
Tocatta and Fugue in D Minor  
**WAGNER**  
Die Meistersinger Prelude, Act 1  
**MOUSSORGSKY**  
Night on Bald Mountain  
**BRAHMS**  
Academic Festival Overture  
**DUKAS**  
Sorcerer's Apprentice

The Musical Masterpiece Society, Inc., Dept. 88-2  
43 West 61st Street, New York 23, N. Y.

Enclosed is \$1 in full payment for the recordings of 8 masterpieces listed. Enroll me as trial member. Privileges: No purchase obligation ever! Advance notice of releases. 5 day free trial on any discs. I may reject records before or after receipt; may cancel membership at any time. For future 1-p. discs I keep, I'll pay only \$1.00 each plus shipping.

Name.....  
Address.....  
City.....State.....  
Canada, address: 686 Bathurst St., Toronto 4, Ont.

## BOOK REVIEWS

**ELECTROACOUSTICS, The Analysis of Transduction and its Historical Background.** By Frederick V. Hunt, Gordon McKay, Professor of Applied Physics, Harvard University. Harvard University Press. John Wiley & Sons, Inc., New York. 260 pages, illustrated, 1954. \$6.00.

Friends and acquaintances of Professor Hunt will not be particularly surprised to find in this volume the most worthwhile assembly of information on the subject at hand yet to be published in a single text. Those who have not enjoyed the good fortune of the professor's acquaintance will find surprise in the intelligent presentation of information both theoretical and practical, so arranged that it is of equal interest to the designer and the production man.

In other words, Professor Hunt has demonstrated once more his acute ability to sift through all available information on a given subject, and present the bulk of its worthiness in a volume of practical size and excellent readability.

Although the entire field of electroacoustics is covered with both thoroughness and authority, particular interest will be found in the chapter dealing with electrostatic speakers. First presented commercially some thirty years ago, when it was generally known as a "condenser" speaker, it was found to be impractical on three scores: (1) need of excessive polarizing voltages; (2) lack of suitable dielectric material for separation of the moving diaphragm and its stationary back-plate, and (3) inability to reproduce low frequencies. Re-evaluation of the electrostatic speaker in the light of materials available today has nullified the first two weaknesses, while the decision to use it only as a tweeter has mitigated the third. In addition to covering these points, Professor Hunt discusses the relative merits of utilizing single- and double-sided polarization of the moving diaphragm.

Equal thoroughness is accorded the design and construction of other electroacoustic devices such as dynamic speakers and various types of microphones.

—H. K. R.

**VALVES FOR A.F. AMPLIFIERS**, by E. Rodenhuis. Philips Technical Library, N. V. Philips Gloeilampenfabrieken, Eindhoven, Nederland. Dist. in U. S. by Elsevier Press, Inc., 155 E. 82nd St., New York 28, N. Y. and 402 Lovett Blvd., Houston 6, Texas. 155 pp., 97 illus. 1954. \$2.25.

While written with the Philips line of tubes in mind, the information in this small book is worthwhile for the amateur constructor regardless of the line of tubes used. The first chapter covers general hints on amplifier construction, with special consideration to the mounting of components, assembly, wiring, and general information.

Components and circuits, and their effect on tube performance are discussed in Chapter 5, and the last chapter is devoted to presenting the details of eight complete amplifiers ranging from a simple 3-watt unit suitable for the smallest installations up to a 100-watt amplifier, with two excellent 35-watt models being included.

Although much of the information is specific for the Philips tubes, as would be expected, anyone who uses tubes at all would certainly find the book well worth reading, and the ideas presented therein might well bear consideration to the amateur as well as the commercial amplifier builder, in spite of typographical errors throughout.

—R. G.

## NEW PRODUCTS

(from page 48)

• **Concertone Tape Recorder.** Although designed essentially for home and semi-professional use, the new Concertone Model 20/20 embodies virtually all of the features usually found only in professional tape recorders. Among these features are: Use of 10½-in. reels without extension arms; a head mount with provision for up to five heads; three motors, including a two-speed induction motor for direct tape drive, and a 4½-in. db meter. Frequency response permits useable signal from 20 to 20,000 cps at 15 ips, with flutter and wow less than 0.1 per cent rms. The 20/20 is available with speeds of either 7½ and 15, or 3¾ and 7½ ips. It is supplied normally with dual-track heads but may be had with single-track heads on special order. Rewind and fast-



forward speed permits transferring a 2400-ft. spool of tape in either direction in less than one minute. Manufactured by Berlant-Concertone, 4917 W. Jefferson Blvd., Los Angeles 16, Calif.

• **G-E Equipment Cabinet.** Both handsome and functional is the new hi-fi equipment cabinet recently announced by General Electric Company, Electronica Park, Syracuse, N. Y. Designed as a companion piece to G-E's hi-fi speaker enclosure, the equipment cabinet is finished on all four sides and can be used as a divider unit, as a piece of chairside furniture, or to occupy wall space. The top compartment



holds the tuner, preamplifier, and record player. Two lower compartments are designed for housing a power amplifier and for record storage. The record compartment can be opened from either side. The cabinet will accommodate all leading makes of high-fidelity components, and is supplied with removable blank mounting panels.

• **Improved Fairchild Cartridge.** Constructed on the high-compliance moving-coil principle, the new Fairchild Series

220 cartridge has improved characteristics which represent a measurable advance in cartridges of this type. Frequency response is flat to 17,000 cps with a gradual roll-off which results in constant over-all response covering the entire audio range.

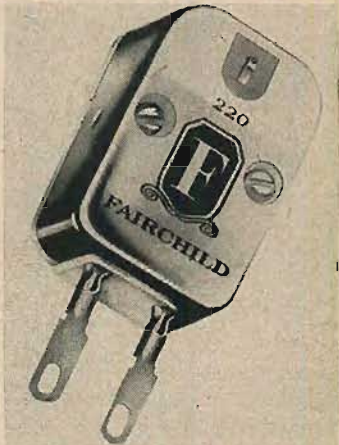

A 4- to 6-db increase in signal level over that of earlier Fairchild models simplifies installation in any hi-fi music system. The 220 is available for either micro-groove or 78-rpm records. Fairchild Recording Equipment Company, 154th St. and 7th Ave., Whitestone, N. Y.

• **Bonette Crystal Microphone.** Famous throughout other parts of the world, the Bonette Type B-110 microphone is now being introduced in the U.S.A. by Ronette Acoustical Corporation, Importers. This unit is designed specifically for clear speech, and is excellent for any



communication application as well as for public address and paging systems.

The output level, when working into a 5-meg load, is 1 millivolt per microbar; the response curve when working into the recommended 10-meg. load is flat from 30 to 1000 cps, and rises gradually to a 20-db peak at about 4000 cps, then drops gradually to normal level, and extends to 13,000 cps. Attenuation of bass response for incisive speech quality may be obtained by using loads as low as 0.22 meg; any intermediate degree can be obtained by varying the load resistance. The microphone is semi-directional in characteristic, and represents a source impedance of 2200 µf. The diaphragm is aluminum, and the case is of a high-impact plastic in either ivory or black, or a combination of both. The crystal unit is vacuum sealed, and is fully guaranteed for use in tropical countries. For further information on the complete Ronette line, address Ronette Acoustical Corporation, 135 Front Street, New York 5, N. Y.

## Only the MIRACORD XA-100 has the "Magic Wand"

The only spindle that treats your precious records with the care they deserve. No more "out-of-round" center holes. No rumble; no wow.

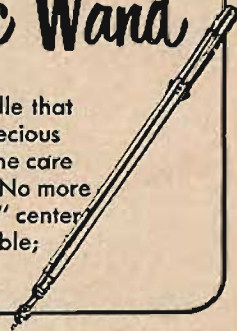

### THE MIRACORD XA100

is for sale at all leading distributors throughout the United States. If you are interested in High Fidelity you owe it to yourself to see and hear this remarkable instrument.



### Plus PUSH BUTTON CONTROL.

Every operation of this remarkable changer is simply controlled by four push buttons

### Plus PAUSAMATIC

Now you can automatically preset the time lapse between record changes, from 5 seconds to 5 minutes

### Plus ALL THESE FEATURES

- No Wow.
- No rumble.
- Intermixes 10" and 12" records.
- Interchangeable plug-in heads.
- Ball-bearing-suspended turntable and tone arm.
- Adjustments without tools.
- Rubber matted turntable.
- All 3 speed settings controlled by single knob.
- Shipped complete with leads and plugs, ready to play.

## AUDIOGERSH CORPORATION

23 Park Place, N. Y. 7, N. Y.

## The *Audio Console* preamplifier



QUALITY DESIGNED  
by  
**marantz**

There was a clearly defined purpose in developing the Marantz Audio Console: to create a control unit embodying advanced design thinking coupled with the best available components and finest construction technique. The results have more than justified this extra effort and care. For practical efficiency...for sheer quality of performance, the Marantz Audio Console is unmatched by any unit on the market.

**These are the features:** • 7-position Selector Switch • Continuously Variable Bass and Treble Controls • Independent Turnover and Rolloff Controls • Loudness Compensator\* (does not affect volume) • High Frequency Cutoff Selector • Frequency Response: 17 to 40,000 cycles  $\pm 1$ db • Negligible IM Distortion (less than .03% at 2-volt output).

User's Net Price complete with tubes and cabinet \$155  
Chassis (less cabinet) available at lower cost

Wherever Fine Audio Equipment is Sold

Write for Complete Details:

**s. b. marantz** 44-15 Vernon Boulevard, L. I. C. 1, N. Y.

## HERE IS TELEVISION FOR YOUR HIGH FIDELITY SOUND SYSTEM

Designed and custom-built to operate through your high fidelity amplifier and speaker system (or independently, if you wish). In this way, you enjoy the VIDEO quality of Tech-Master's advanced 630-type design and the AUDIO quality of your own high fidelity system.

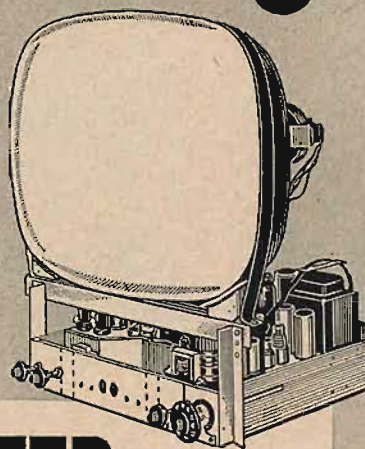

## TECH-MASTER GOLD MEDAL TV CHASSIS

Designed for use with Home High Fidelity Systems



Illustrated Brochure Upon Request  
**TECH-MASTER CORPORATION**  
75 Front Street, Brooklyn 1, N. Y.

## JAPAN GOES HI-FI

(from page 23)

diminishing, will continue to remain a factor until the Japanese-manufactured components of Japanese design are more widely accepted by the Japanese themselves.

The newly formed Tokyo Chapter of the American Audio Engineering Society is rapidly taking the initiative in establishing engineering standards, arranging Audio Fairs, and in providing a medium for publication and discussion.

From November 27th to December 5th, an Audio Fair sponsored by the Nippon Audio Association was held in Tokyo with a total attendance of more than 55,000 persons. Forty nine manufacturers participated with display booths at one of Tokyo's largest department stores, the Matsuya.

Technical papers were presented by members of the Audio Engineering Society, and numerous demonstrations of Hi-Fi components were given. One interesting experiment involved a three-channel stereophonic broadcast by radio stations—JOKR, JOFR, and JOQR. Since the broadcast was made on standard broadcast frequencies, the general public participated by merely using three receivers and loud-speakers spaced around a room.

In order to provide optimum demonstration facilities for the exhibiting manufacturers, a special listening room was constructed for the use of the exhibitors. With this arrangement, loud-speaker silence was maintained in the display area, and each company was assigned a short demonstration period.

The Japanese are great music lovers as evidenced by the very crowded Tokyo auditoriums featuring both classical and jazz concerts several times each week, and by the numerous publications devoted to music. Along the Ginza, in Shimbashi, and in other night-club areas of Tokyo, Yokohama, Kobe, and Osaka, one can hear the nightly strains of nothing but American dance music being played by Japanese orchestras. It is necessary to move out into the country to hear the purely Japanese Odori dance music.

Barring a major political upheaval in the Far East, Japan can be expected soon to become a large producer of hi-fi parts, and with improved component engineering hi-fi has an excellent chance to outsell and outclass other electronics industries in Japan.

It is a safe bet to predict that within the near future no self-respecting Japanese coffee shop in Tokyo (of which there are thousands) will be without a hi-fi system to soothe its music-hungry patrons!

### LOOK FOR US

at the

Audio Fair • Los Angeles  
Alexandria Hotel, Room 543

### AUDIO

AUDIO • FEBRUARY, 1955



## MINIATURE PREAMPLIFIER DESIGN

(from page 21)

equipment. Therefore, it becomes entirely feasible to use only a treble rolloff control with a maximum droop of 15 to 20 db in a system with an adjustable boost. Once set for a given equipment lineup, the boost adjustment need not be altered. The range of net adjustment can be seen in Fig. 2.

### The Miniature Preamplifier

The simplifications made thus far can be carried out in a spectacular manner. To illustrate, a very satisfactory preamplifier was constructed with a single tube! However, two tubes are used in the unit shown in Figs. 3 and 4 to bring the midband gain up to a more acceptable level for general use. Output with the two-tube arrangement is 2 to 3 volts with a 10-mv input, as compared to 0.5 volt output with a single tube (triode-pentode).

At first glance, the schematic of Fig. 1 may be somewhat confusing. Aside from the obvious functions that a closer study will reveal, there are several *hidden* effects derived from careful component arrangement. Perhaps the best manner of description would be an over-all picture and then a clarification of the details.

Three input jacks are provided. One is for a magnetic cartridge or microphone and the other two accommodate normal high-level, high-impedance devices. The 6-position selector switch performs the following:

Pos.	Name	Function
1	Phono 1	Normal phonograph position
2	Phono 2	Phonograph position for moderately noisy records
3	Phono 3	Phonograph position for very noisy records
4	Microphone	Position for using a low-level microphone in phonograph jack
5	Radio	Radio tuner
6	Auxiliary	Television sound or tape recorder

Positions 1, 2, and 3 retain the amplification of the first stage, keep a reference equalizer in the circuit and control the upper limit of frequency response. Position 1 yields a flat response, while 2 and 3 furnish cutoffs at 12 db per octave starting at about 6 kc and 4 kc respectively, by resonating the capacitor switched across the input grid with the inductance of the pickup.

Although one is inclined to shudder

at the prospect of a 4-kc limit to response, the effect is not the same undesirable one that would be obtained with a filter of much higher slope—say 30 db per octave. Using 4 and 6 kc with the simple, well known filter arrangement shown in the schematic affords most effective removal of record noise and distortion with a minimum apparent loss of highs.

Position 4 retains only the 200-times, flat-frequency-response amplification of the first stage. The remaining two positions, 5 and 6, switch the radio and auxiliary inputs directly to the second stage. The reference equalizer is not effective in these last three positions.

### Bass Circuit

Most of the burden is carried by the second stage. Variable bass boost is achieved by selective feedback from plate to grid. The plate circuit is loaded with the series arrangement of  $R_{11}$ ,  $R_{12}$ , and  $C_{11}$ . Output is taken through the treble-control potentiometer. This configuration forms the backbone of the circuit.

In the phonograph positions,  $C_{11}$  is effective. In other positions, it is shorted to ground. While in the circuit, it provides the reference equalization curve. Not so readily apparent is the fact that this capacitor in conjunction with  $R_{11}$  and  $R_{12}$  forms a *frequency-sensitive* load on the second stage. This causes the amplification to rise somewhat with lowered frequencies. Therefore, the feedback bass control is exceptionally efficient and gives about 6 db more boost than would normally be expected. As an added result, the equalization curve approaches the theoretical ideal. This gives additional boost with a straight-lined 6-db-per-octave slope instead of the usual rounded and depressed curve.

There is further advantage to this circuit arrangement. Treble rolloff is easily accomplished, but more significant, cable capacitance can be fully offset! This eliminates the need for a low-impedance output such as a cathode follower. Theoretically, the upper response can be in the megacycles if desired.

With an additional step, complete treble control is obtained. By overcompensating the cable capacitance, the upper frequency response can be boosted to any required amount. An adjustable trimmer  $C_{11}$  performs this operation. The rolloff circuit is designed to give a maximum attenuation of about 20 db at 10 kc. The range of control thus afforded is complete for most imaginable circumstances.

There are several other design features worth noting. Coupling constants are chosen to give a fairly steep attenuation below 20 cps, providing a good measure of rumble and flutter elimination. At higher volume-control settings, the balance between the two branches

# Aphonic

## PERFORMANCE

the

# MIRAPHON

## XM-110

manual player

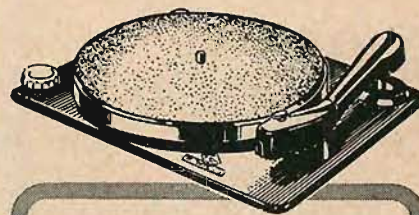

\*The MIRAPHON XM-110 now offers true aphonic performance; it has been created especially for the most exacting of High Fidelity connoisseurs. A manual player offering the utmost in listening enjoyment.

## Double Check

### THESE FEATURES:

- No wow; no rumble.
- Ball-bearing suspended turntable and tone arm.
- Fingertip adjustment without tools.
- 4 pole motor
- Specially constructed plug-in head to accommodate user's choice of cartridge.
- Shipped complete with leads and plugs, ready to play.

Arrow Electronics

**Audio Center**  
ALWAYS AN AUDIO FAIR  
65-A CORTLANDT ST., NEW YORK 7, N.Y.

of the feedback bass-control network is upset and bass droop is effected at the extreme lower settings of the bass control. Should additional droop be needed for a phonograph input, the selector switch can be set to the microphone position. To place FM reception on a par with recorded material, the 75-microsecond de-emphasis network at the output of most receivers can be bypassed.

Since the input stage is non-frequency-sensitive, maximum signal-to-hum is realized. With the bypassed cathode arrangement, hum is extremely low.

With careful wiring and appropriate regard to grounds placement (mainly a matter of returning the heaters to a separate and lower-than-signal ground) hum can be reduced to 60 or 70 db below signal level.

Pentode operation in the first stage favors signal-to-noise ratio as compared to an equivalent triode because of the low input signal. Distortion is somewhat higher. Even so, it is a matter of arguing trifles. Distortion is not discernible at any level. Measurements indicate the order of 0.25 per cent at the overload point and .05 per cent with normal settings.

Much remains towards simplification of the means of controlling sound reproduction—particularly for home use. It is hoped that future trends in audio equipment design will be to accomplish the necessary results in a more concise manner than has been observed to date.

#### PARTS LIST

$C_1$	.003 $\mu$ f, 400 v, paper
$C_2, C_6, C_{12}$	.01 $\mu$ f, 400 v, paper
$C_3, C_7$	25 $\mu$ f, 6 v, electrolytic
$C_4, C_{10}$	0.1 $\mu$ f, 400 v, paper
$C_5, C_{11}$	.002 $\mu$ f, 400 v, paper
$C_7$	200 $\mu$ f, 400 v, ceramic
$C_8$	.02 $\mu$ f, 400 v, paper
$C_{12}$	100-500 $\mu$ f, adjustable
$C_{14}$	400 $\mu$ f, 400 v, ceramic
$J_1, J_2, J_3$	phono pin jacks
$R_1, R_{12}$	27,000 ohms, $\frac{1}{2}$ watt
$R_2$	6800 ohms, $\frac{1}{2}$ watt
$R_3$	4700 ohms, $\frac{1}{2}$ watt
$R_4, R_9$	0.1 meg, 1 watt
$R_5, R_{10}$	
$R_{11}, R_{15}$	560 ohms, $\frac{1}{2}$ watt
$R_6, R_{11}$	0.33 meg, $\frac{1}{2}$ watt
$R_7, R_{11}$	0.1 meg, $\frac{1}{2}$ watt
$R_8$	1.0 meg, $\frac{1}{2}$ watt
$R_{16}$	0.5-meg potentiometer, linear
$R_{17}$	1.0-meg potentiometer, linear
$R_{18}$	0.1-meg potentiometer, linear
	( $R_{17}$ and $R_{18}$ assembled from IRC Concentrikit components)
$S_{20}$	2 pole 6 pos. switch, Mallory 3126J
$V_1, V_2$	6AU6

# HERE'S WHAT AUDIO SAYS ABOUT THE NEW Ronette FONOFUID CARTRIDGE...

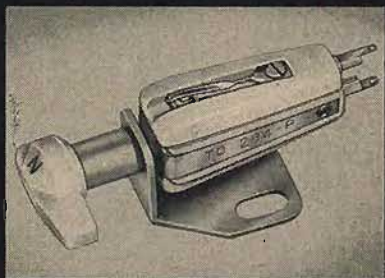

## RONETTE TO-284P PICKUP CARTRIDGE

Interest in phonograph pickups has never abated, and with the introduction of each new one there is speculation as to the performance and its various characteristics.

Tests recently made with the Ronette TO-284P crystal cartridge indicate that it would serve well for high-quality phono reproduction, and to all indications this unit seems to offer some definite advantages.

The cartridge has relatively low output for a crystal—using the Dubbings D-100 test record the measured output with a 1-megohm load on the 3000-cps band is 80 mv—but the other characteristics of the pickup more than make up for this. When working into a load of 1 megohm, the frequency response of the pickup from the test bands of the D-100 test record show a response which is down 4 db at 30 cps, and flat within  $\pm 1$  db from 1000 to 5000 cps, and with a gradual rolloff from 5000 cps to 10,000 cps of 5 db. Thus, when working into a flat amplifier, this pickup would reproduce the RIAA curve correctly with a rolloff of approximately 8 db at 10,000 cps and a boost of 3 db at 50 cps—both of which would be easy to obtain with typical tone control circuits.

If the cartridge is worked into a load of 0.12 megs, the low-frequency curve follows almost exactly the bass-boost characteristic of the RIAA curve, and the performance above 1000 cps remains the same as with the higher load. This means that the cartridge performs almost exactly as a constant-velocity device, and would work correctly with most preamplifiers if the input resistor were changed to 0.12 megs. Curves of these measurements are shown in Fig. 8. The dashed line is the response into a 1-meg load; the dot-dash line is the response into a 0.12-meg load; and the dotted line is the response when feeding into a 0.5 meg load. The solid line is the RIAA characteristic—drawn so as to permit direct comparison. Thus it is seen that the low-frequency performance can be controlled quite readily by choice of the load resistor.

The Cook intermodulation test record shows no measurable distortion on either of the two bands, both of which were re-

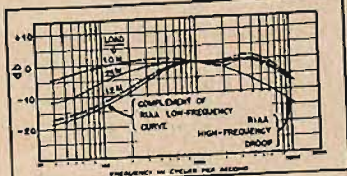

Fig. 8. Performance curves for the Ronette TO-284P crystal cartridge.

corded with 100 and 7000 cps and at two different levels. This was to be expected, considering the exceptionally "clean" quality of reproduction on listening tests. No measurements were made on the 78-rpm side of the cartridge, but it is to be expected that the performance would be equivalent. The construction of the cartridge is such that the idle stylus is not actuated by the playing stylus, and consequently does not introduce the usual dip in the response curve which is the result of the resonance of the free stylus waving in the air.

The cartridge can be mounted in any desired arm. Styli are readily changeable, and the pickup is neat and attractive in appearance. The arm and cartridge track the four lowest-level tracking-test grooves of the Dubbings record with a stylus force of 6 grams; an increase to 7 grams is required for perfect tracking on the "+15" band, which corresponds to a stylus velocity of over 25 cm/sec. Thus for almost any LP record, satisfactory tracking would result from a stylus force of 6 grams.

Since the Ronette cartridge is a crystal, it is not susceptible to hum pickup from magnetic fields—an advantage when used with some of the lower-priced turntables which have this trouble. This would make it especially suitable for use with the small 45-rpm changers, which are infamous for their strong hum field.

In direct listening comparison, this pickup proves that it is not necessary for a crystal pickup to have the typical "crystal" sound often referred to by Mr. Canby in his AUDIO ETC column, and it is probable that most listeners would comment on the "clean" reproduction obtained.

RONETTE ACOUSTICAL CORPORATION  
135 Front Street, New York 5, N. Y.



## POUGHKEEPSIE SOCIETY

(from page 25)

offer advice on problems presented to them both before and after the meetings.

Occasionally we have a "sale and swap" session where arrangements are made between the members for the sale or exchange of equipment or components. We also distribute to the members at times, blueprints of circuit diagrams, speaker enclosures, and the like, so that those who wish to "do it themselves" can enjoy the added stimulation of individual accomplishment.

The Poughkeepsie Audio Society has been successful financially, its members have benefited through their acquisition of knowledge as to the system components, why they are necessary and how to operate them to the best advantage, and last but by no means least every member has been able to advise and assist in the education of newcomers to the high fidelity fold.

This is only the beginning—remember that only 30 years have passed since the electron tube and the microphone and loudspeaker have made possible the recording and playback of a full symphony orchestra.

High fidelity in its true sense of faithful reproduction or sound, with wide range and low distortion, will continue to improve as the years pass and the best way for the increasing number of interested music lovers to keep pace with this progress would seem to be through adult education as sponsored by Audio Clubs or Societies.

Do you know  
you can own

A  
*Stan White*  
SPEAKER  
for only \$49.50



*LePettite*

"the little speaker with the big voice"

You won't believe it, but

Audio Response—55 to 16,000 cps.

Speaker Components—8 inch bass driver in 36 inch exponential horn. 3½ inch tweeter and specially designed crossover network. Impedance: 8 ohms.

Construction—Korina veneers finished in Blonde, Walnut, Mahogany or Ebony hand rubbed lacquer. Wrought iron legs.

Unique Features—Curled, not folded, exponential horn (1% of formula). Multiple flare formula (patent applied for). Passive phasing chambers. 24db/octave acoustical crossover. Distributed throat characteristic (not found elsewhere).

Size—19 x 12 x 9 inches.

Other Stan White Cabinet Speakers

LeSabre—24" x 15" x 12", Frequency Response: 40 to 16,000 cycles.....79.50

Esquire—30" x 24" x 16", Frequency Response: 30 to 16,000 cycles.....194.00

Hi-Fi—4' x 30" x 20", Frequency Response: 20 to 16,000 cycles.....495.00

4-D—5' x 3' x 2', Frequency Response: 15 to 16,000 cycles.....994.00

See your high fidelity distributor or write

*Stan White* INC.

Dept. A-2, 727 S. LaSalle St.  
Chicago 5, Illinois

A Division of Eddie Bracken Enterprises

## ELECTRICAL RESONANCE

(from page 29)

Variation of equivalent shunt components in proportion to  $\omega^2$  can also be shown by means of vectors, as in Fig. 5. The relationship between  $V_r$  and  $I$  is constant, by Ohm's law. The relationship between  $V_L$  and  $I$  is proportional to frequency, so  $\tan \theta \propto 1/\omega$ . The length of  $OV_r$  and  $OI$  both vary as  $\sin \theta$ , and  $OB = OI \sin \theta$ . So  $OB$ , the in-phase component of current, varies in proportion to  $\sin^2 \theta$ . For small values of  $\theta$ ,  $\tan \theta$  and  $\sin \theta$  are sensibly the same. (This can be shown by consultation of tables if the necessary mathematical proof is not convincing. This means that the in-phase component of current varies inversely as the square frequency, provided  $V_r$  is small (not necessarily very small) compared to  $V_L$ . Or the equivalent shunt resistance varies directly as the square of frequency.

### The Complete Circuit

Having clarified the reference of equivalent values in series and shunt components of resistance, this can be applied to the complete resonant circuit, either by means of vectors or the  $j$  technique—both have their advantages.

Figure 6 shows the vector diagrams for equal reactance, which approximates to maximum impedance if  $r/\omega L$  is small, and for zero phase shift of unity power factor. The diagram of (a) is for equal reactances,  $I_c'$ , equal in length to  $I_c$ , representing the current that would flow in  $L$  in the absence of resistance, when the voltage  $V$  would appear directly across it. By similar triangles, reduction of the voltage across  $L$  to  $V_L$  due to the drop  $V_r$  reduces the current in the combination to  $I_L$ . Combination of  $I_L$  and  $I_c$  gives the resultant  $I$ , which is not in phase with  $V$ .

The diagram of (b) represents a condition obtained by a slight drop in frequency. This reduces  $I_c$  slightly and increases  $I_L$  to the new values shown as  $I_c'$  and  $I_L''$ . The quadrature component of  $I_L''$  is equal to  $I_c'$  so that the resultant  $I'$  is in phase with  $V$ .

Now consider the relative lengths of  $OI$  and  $OI'$ ; this is illustrated in Fig. 6(c). If  $I_c$  remained constant and  $I_L$  were increased without changing its phase angle until its quadrature component equalled  $I_c$ ,  $OI'$  would bear the exact relationship to  $OI$  shown in (c). But  $I_c$  reduces this change by approximately half, and the change in  $I_L$  is reduced to approximately half but  $\theta$  also changes, so that  $I_L$  and  $V_L$  remain at right angles. The net result is that  $OI'$  has approximately the relationship to  $OI$  shown in (c) and  $I'$  is part of the locus of the  $I$  vector. Obviously, within the approximation made,  $OI$  is the shortest length of  $I$ , representing maximum impedance.

Using the  $j$  technique the expression for  $I$  is obtained:

## TRANSCRIPT

of Silence

the

MIRACORD

XA-100

record changer

The superb craftsmanship of the Miracord XA-100 permits only the recording, not the surface noise of the record, to reach your ear!

LEONARD

has it!



The Miracord XA-100 comes equipped with the "Magic Wand" spindle that preserves the life of your precious records.

Plus ALL THESE FEATURES

- No Wow.
- No rumble.
- Intermixes 10" and 12" records.
- Interchangeable plug-in heads.
- Ball-bearing-suspended turntable and tone arm.
- Adjustments without tools.
- Push button operation.
- Pausomatic — the user's choice of time lapse between records from 5 seconds to 5 minutes.
- Shipped complete with leads and plugs, ready to play.

LEONARD RADIO, INC.

Audio Mart 69 Cortlandt St.,  
New York 7, N. Y. Cortlandt 7-0315

**SAVE  
25%**



This is our

**GROUP SUBSCRIPTION PLAN**

Now you, your friends and co-workers can save \$1.00 on each subscription to **AUDIO**. If you send 6 or more subscriptions for the U.S., Possessions and Canada, they will cost each subscriber \$3.00 each, 1/4 less than the regular one year subscription price. **Present subscriptions may be renewed or extended as part of a group. Remittance to accompany orders.**

**AUDIO is still the only publication devoted entirely to**

- Audio
- Broadcasting equipment
- Acoustics
- Home music systems
- Recording
- PA systems
- Record Revues

(Please print)

Name .....  
Address .....

New  Renewal

Name .....  
Address .....

New  Renewal

Name .....  
Address .....

New  Renewal

Name .....  
Address .....

New  Renewal

Name .....  
Address .....

New  Renewal

Name .....  
Address .....

New  Renewal

U. S., Possessions, and Canada only

**RADIO MAGAZINES, INC.**

P. O. Box 629, Mineola, N. Y.

$$\frac{I}{V} = \frac{r + j\omega(Cr^2 - L) + j\omega^2 L^2 C}{r^2 + \omega^2 L^2} \quad (8)$$

The condition for unity power factor requires the imaginary term to be zero, or

$$\omega^2 = \frac{L - Cr^2}{L^2 C} = \frac{1}{LC} - \frac{r^2}{L^2} \quad (9)$$

The condition for maximum impedance is obtained by differentiating the modulus of (8) with respect to  $\omega$ , and equating to zero, leading to the expression

$$\omega^2 = \frac{1}{LC} \left[ \sqrt{1 + \frac{2r^2 C}{L}} - \frac{r^2 C}{L} \right] \quad (10)$$

If  $r/\omega L$  is small, then  $r^2 C/L$  is very small, being its square at resonance, so the expression in brackets reduces to unity, making  $\omega^2 = 1/LC$ , which is the condition for equal reactances.

**Other Circuits**

A further variety of circuits can be investigated in more advanced treatments, if desired, of which the simple ones in Figs. 3 and 1 (for parallel resonant circuits) become special cases. In practice, resistance components vary in a way more difficult to show than these simple laws. Where iron cores are used, hysteresis losses have to be included for complete representation. Ignoring the fact that these losses cannot be represented by a constant resistance, even at one frequency, as amplitude is varied, because the Steinmetz coefficient differs from 2, hysteresis could be resolved as equivalent to either a shunt or series component whose value varies in direct proportion to frequency. So the complete impedance and admittance expressions for an inductor would take the form

$$Z = r + \omega H + \omega^2 E + j\omega L \quad (11)$$

and

$$Y = E + \omega H' + \omega^2 G' + \frac{1}{j\omega L'} \quad (12)$$

where  $r$  is actual winding resistance and  $\omega^2 G'$  is its referred conductance:  $E$ ,  $E'$  and  $H$ ,  $H'$  stand for components due to eddy current and hysteresis losses, respectively. Provided the losses are small compared to  $\omega L$ , either of these expressions could be used with equal validity, and  $L$  is almost identical with  $L'$ . Where the losses are no longer small, choice of approximation has to be made with reference to the relative values: if  $r$  is larger than the combined core losses, (11) gives the best approximation, while if the core losses are the greater, (12) is best suited.

For a simplified approach, which is often quite satisfactory, a fixed value of loss resistance can be used, but it is best to use a series component for the series circuit or a shunt component for the shunt circuit, as in Figs. 2 and 3. This approach ignores the possible difference between impedance maximum or minimum and unity power factor frequencies, but otherwise involves less error than the use of Fig. 1 for the shunt circuit.

**Other Variables**

So much for treatment considering

**Just Published!**

The first book in the field to show you how to design, build and use

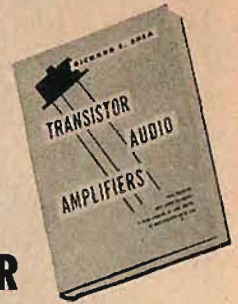

**TRANSISTOR  
AUDIO AMPLIFIERS**

By RICHARD F. SHEA  
General Electric Company

In this important new work, Mr. Shea shows how transistor fundamentals can be applied in the construction and use of audio amplifiers. Clearly and with a minimum of mathematics, he explains how you can: (1) intelligently apply transistor principles in a multitude of designs, (2) avoid pitfalls in planning, and (3) achieve the ultimate in performance from transistor devices.

Here are all the tools you need to design an audio amplifier which meets the prerequisites of frequency response, signal-to-noise ratio, input power, and output power in such a manner as to insure maximum reproducibility, long life, maximum freedom from the effects of temperature and humidity, and lowest cost.

1955 219 pages Illustrated \$6.50

**Principles of  
TRANSISTOR  
CIRCUITS**

Edited by RICHARD F. SHEA  
General Electric Company

The first full-length, integrated work on transistor characteristics and circuits. "We believe that this definitive work will soon be known as the 'bible' of the transistor engineer. Its appearance will offer, between two covers, a single source for the cream of current thinking on the subject."—Radio & Television News.

1954 535 pages 502 Illustrations \$11.00

Mail now for your ON-APPROVAL copies  
AE-25

**JOHN WILEY & SONS, Inc.**  
440 Fourth Ave., New York 16, N. Y.

Please send me the book(s) checked below to read and examine ON APPROVAL. Within ten days I will either return same and owe you nothing, or will remit the price(s) indicated, plus postage.

- Transistor Audio Amplifiers, \$6.50
- Principles of Transistor Circuits, \$11.00

Name .....

Address .....

City ..... Zone ... State .....

SAVE POSTAGE! Check here if you ENCLOSE payment, in which case we pay postage. Same return privilege.

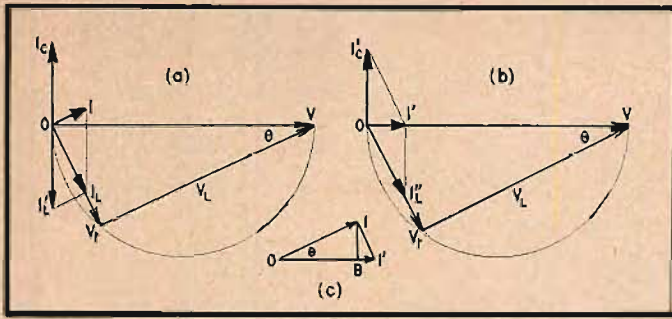

Fig. 6. Vector diagrams for (a) equal reactance, which approximates maximum impedance, and (b) for unity power factor in circuit of Fig. 1.

the frequency as the variable. In practice, sometimes  $L$  or  $C$  (or even  $R$  on occasion) is varied to bring the circuit to maximum or minimum impedance at a fixed frequency. If either of the simple circuits of Figs. 2 and 3 are used, maximum or minimum impedance and unity power factor occur coincident with the condition for variation of frequency. But with the circuit of Fig. 5 and other practical circuits, conditions do *not* coincide.

Using the conventional arrangement of Fig. 1 as an example, the condition can be found by differentiating the modulus of (8) with respect to  $L$  or  $C$  and equating to zero. For variation of  $L$ , this gives

$$\omega L = \frac{1}{\omega C} [1 + \sqrt{1 + C^2 r^2}], \quad (13)$$

or for comparison with the other conditions,

$$\omega^2 = \frac{1}{LC} + \frac{r^2}{L^2} \quad (13a)$$

For variation of  $C$ , the condition for maximum impedance is

$$\frac{1}{\omega C} = \omega L + \frac{r^2}{\omega L} \quad (14)$$

or

$$\omega^2 = \frac{1}{LC} - \frac{r^2}{L^2}, \quad (14a)$$

which is the same as (9) for unity power factor in this case, but need not be in practical circuits because there may be other components of resistance.

Besides all these possibilities with resonant circuits under continuous-wave

condition, there is the natural frequency of the circuit, which requires the solution of a differential equation. Only a closed loop can be considered here, so there is no question of series or parallel circuit. However, the position and characteristic of the resistance will affect the question. For the circuit of Fig. 3 the natural frequency will be the same as resonance, but with the circuit of Fig. 1 the well known frequency

$$\omega^2 = \frac{1}{LC} - \frac{r^2}{4L^2} \quad (15)$$

is derived. The difference from other frequencies can be understood from the fact that the steady-state cases have energy supplied to the resonant circuit to maintain oscillations, whereas the natural frequency appears when an initial store of energy in one of the reactances is delivered up to the resistance element during oscillation of energy between the circuit reactances.

Figure 7 shows the relevant steady-state frequencies for the circuit of Fig. 1;  $f$  is where the reactances are equal and is sensibly the same as maximum impedance for this arrangement;  $f'$  is the frequency for unity power factor, and  $f''$  the frequency for equal current in the two branches, which has little practical significance. Its value can easily be found by equating the moduli of the expressions for current in each branch, giving

$$\omega^2 = \frac{1}{LC} \left[ \sqrt{1 + \frac{r^2 C^2}{4L^2}} - \frac{r^2 C}{2L} \right] \quad (16)$$

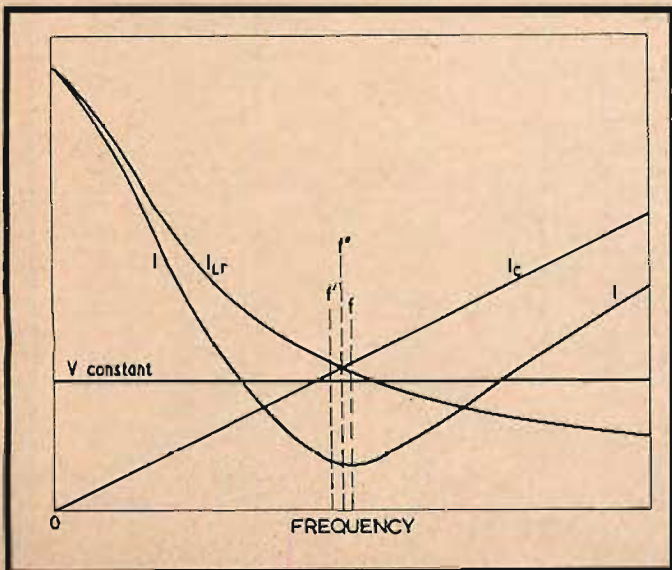
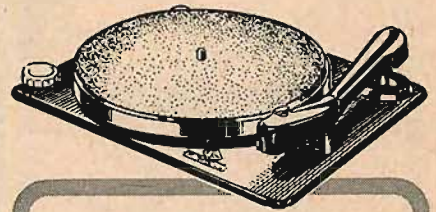

Fig. 7. Curves relevant to the resonance of the parallel circuit of Fig. 1 with constant applied voltage.

# Aphonic PERFORMANCE

## the MIRAPHON XM-110 manual player



\*The MIRAPHON XM-110 now offers true aphonic performance; it has been created especially for the most exacting of High Fidelity connoisseurs. A manual player offering the utmost in listening enjoyment.

### Double Check

#### THESE FEATURES:

- No wow; no rumble.
- Ball-bearing suspended turntable and tone arm.
- Fingertip adjustment without tools.
- 4 pole motor
- Specially constructed plug-in head to accommodate user's choice of cartridge.
- Shipped complete with leads and plugs, ready to play.

Radio • Audio • Video • Electronic Equipment  
Phone: WOrth 4-3311  
**Terminal**  
RADIO CORP.  
85 Cortland St. • New York 7, N. Y.

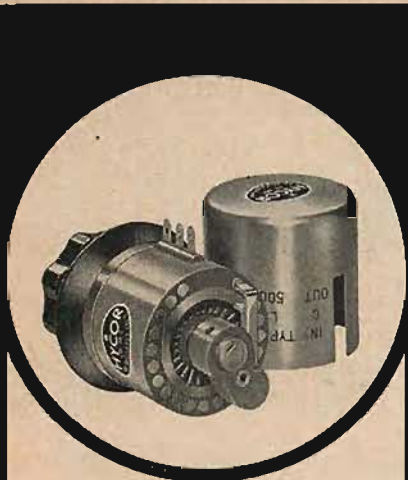

The Completely New

**HYCOR**

## VARIABLE ATTENUATOR

... A revolutionary design in attenuators!

- PROOF against SHOCK—MOISTURE—TEMPERATURE.
- Withstands ambient temperatures of  $-40^{\circ}\text{C}.$  to  $+70^{\circ}\text{C}.$ ; 95% humidity.
- Resistive elements are accurate, non-inductive, wire-wound and hermetically sealed in a special tough plastic compound.
- Greater power dissipation.
- Switch surface flat and smooth... easy to clean, BRUSHES CANNOT TRIP, exceptionally long life.
- QUIET...extremely low switch noise level... ideal audio mixer controls.
- "Lubricated for life" bearings.
- Stock types available with "LADDER," "T," "H," "L," and potentiometer configurations up to 32 steps.

Send for Bulletin A-2 for specifications and prices.

Representatives in  
Principal Cities

**HYCOR**  
Company, Inc.

11423 VANOWEN STREET  
NORTH HOLLYWOOD 3, CALIF.

$$\approx \frac{1}{LC} \left[ 1 - \frac{r^2 C}{2L} \right] = \frac{1}{LC} - \frac{r^2}{2L^2} \quad (16a)$$

The natural frequency is midway between  $f$  and  $f'$ .

Just a word about dynamic impedance. In the circuit of Fig. 3 it is obviously simply  $R$ . In the circuit of Fig. 1 it is usually defined as the impedance at unity power factor, or when the circuit is resistive. Substituting (9) into the real part of (8) (which makes the imaginary part zero) gives

$$\frac{1}{V} = Y_d = \frac{Cr}{L} \quad \text{or} \quad Z_d = \frac{L}{Cr} \quad (17)$$

the latter form being the familiar one. The maximum impedance, found by substituting (10) into (8) gives a slightly higher impedance but it is not resistive:

$$Z_m = \frac{L}{Cr} \sqrt{1 + \frac{r^2 C}{L}} \quad (18)$$

It is hoped that enough has been stated to show that a new approach to resonance is due. Attention has been confined to three basic circuits. Similar results appear on introducing a shunt resistance component to the inductance in the series circuit, which also has practical significance, but more detail of these possibilities has not been given in an endeavor to avoid obscuring the forest with trees.

The approach herein suggested has the advantage that the initial simple circuits of Figs. 2 and 3 both conveniently bring all the critical frequencies together. The fact that other circuits deviate can easily be realized by converting them to equivalents of these forms. The resistance values will then possess a frequency characteristic which shows why maximum or minimum impedance will differ from the frequency for unity power factor or in-phase condition.

One more point the author would like to put forward: it concerns the definition of  $Q$ . It is often taken as essentially associated with a resonant circuit. British Standard 204: 1943, No. 1152 (c), gives the  $Q$  factor of a coil or capacitor as the ratio of the reactance to the series resistance (italics author's). The author suggests that the relation between the imaginary and real components of its impedance or admittance would be a more widely applicable definition.

### MANUFACTURER'S SURPLUS

Build your own Electronic Organ from these basic units: 60-note triple-stacked shunt keying mechanisms, octave wired isolating resistor to each palladium contact. Three types available: Great 16', 8', 4'; Swell 8', 4', 2 1/2'; Single Manual 16', 8', 4', including 12 pedal bass notes. \$10.00 each. Tone generator sub-assemblies, consisting of 21 400- and 600-volt capacitors and 15 resistors, \$.50 each. Special linear-movement swell controls in 60 steps, 100,000 ohm resistance. \$5.00 each. Minshall Organ Inc., Brattleboro, Vermont.

BOZAK B-305, blonde cabinet, \$200. S. Leen, Hyannis, Mass.

VARTYPING (inexpensive typesetting) and paste-up of engineering papers, instruction manuals, tables, etc. Catherine Rein, Wisconsin 7-1220, New York City.

BOUND VOLUMES 1954 ISSUES AUDIO MAGAZINE NOW AVAILABLE—\$10.00 each postpaid. U. S. Delivery only. Send order and remittance today. Box CF-4, Audio, P. O. Box 629, Mineola, N. Y.

## CLASSIFIED

Rates: 10¢ per word per insertion for noncommercial advertisements; 25¢ per word for commercial advertisements. Rates are net, and no discounts will be allowed. Copy must be accompanied by remittance in full, and must reach the New York office by the first of the month preceding the date of issue.

THE AUDIO EXCHANGE has the largest selection of new and fully guaranteed used equipment. Catalog of used equipment on request. Audio Exchange, Dept. AE, 159-19 Hillside Ave., Jamaica 32, N. Y. OL 8-0445  
AUDIO EXCHANGE EXCHANGES AUDIO

DIAMOND NEEDLES: Custom re-tipping of your phonograph needle or cartridge with broadcast quality diamond. For information and price write to: Transcriber Company (Diamond Stylus Manufacturers), 70 Pine St., Attleboro, Mass.

FM ANTENNAS. Standard and special types. Installation accessories. Wholesale Supply Co., Lunenburg, Mass.

ALLIED 16-in. professional overhead, 120 lines per inch, spiraling, like new, \$100. FAIRCHILD studio pickup, equalizer, \$45. Box CF-1, AUDIO.

WILL SELL AS A UNIT ONLY: Two Presto 6-N three-speed disc recorders in 4-B studio cabinets. One has cutter lift-off for masters. Both have Van Eps heads, special suction jets, hot-stylus kits, W.E. 9A and Gray playback systems. Included are two Altec A256C 75-watt recording amplifiers, one custom line amplifier with corrective equalization for recording heads, selective equalizers for flat recording, AES, and NAB curves. Also included are eleven outside-in feedscrews: 2-88, 2-96, 2-112, 2-136, 1-176, 1-224, 1-272 lines per inch. Original net cost \$3260. Asking \$2360, which is \$900 below our cost. Demonstration by appointment. Reco-Art Sound Recording Company, 1305 Market St., Philadelphia, Pa.

INTERELETRONICS Williamson Amplifier, used less than one hour, \$63; University 4408 tweeter, \$11; University 4402 tweeter, \$14; University 4410 crossover, \$13; University 4420 crossover, \$7; Wharfedale W12/CS woofer, new, \$35; Altec 400B 8-in. speaker, \$15. A. Holzel, 1940 Great Neck Road, Copiague, L. I., N. Y.

FOR SALE: Capps model 2A condenser microphone. Complete with power supply and all connecting cables. Excellent condition, used only few hours. A really high quality microphone for only \$125. Glen Southworth, Box 284, Moscow, Idaho.

FOR SALE: Altec 303A FM-AM tuner in excellent condition. Has preamplifier and equalizer. Price \$125. Cost new \$279. C. H. Goddard, Fitzwilliam, N. H.

AMPEX 402P half-track, heads factory reconditioned, \$650; Rek-O-Kut RKD-16 with overhead cutter and composite amplifier, \$90. United Radio Supply, 22 NW 9th Ave., Portland 9, Oregon.

AMPLIFIERS—HI-FI 45% off 40,000-cycle amplifiers, recorders, pianos, organs, accordions, typewriters, movie equipment, binoculars. Amazing bargains. ABELMART, 466 Belmont, Patterson 2, New Jersey.

WANTED: Proctor-Soundex turntable, with arm and clips, in good operating condition, at interesting price. Adolph Hoefler, 8330 Kingsbury, Clayton, Mo.

RECORDISTS! EXCHANGE talking and musical tapes internationally. Box 1404-J, San Francisco 1, Calif.

FOR SALE: Business—manufacturing, assembling high-fidelity console sets, speaker enclosures, using standard components, excellent product, \$6000, mostly for inventory, no test equipment. Selling for lack of capital. Write Box CF-2, AUDIO.

STAMP COLLECTOR will exchange high fidelity equipment for fine stamps. Prefer U. S. and British Empire. Completion of personal hi-fi system has resulted in surplus of excellent equipment, including all components with new guarantee on a try-it-first basis. All correspondence will be answered. Box CF-3, AUDIO.

KLIPSCHORN, Blonde finish, including top enclosure and woofer, but has no tweeter or crossover, \$170. BE 5-4911R, Belmont, Mass.

## PROFESSIONAL DIRECTORY

**"WE HAVE IT"**  
HI-FI COMPONENTS EXCLUSIVELY  
**HOLLYWOOD ELECTRONICS**  
7448 MELBOURNE AVE.  
HOLLYWOOD 46  
CALIFORNIA  
WE 2-11208

## HIGH-FIDELITY HOUSE

Offering the World's Finest Home Music Systems, created by experts with years of experience. High Fidelity is our only business—not a sideline. *Complete stock of every worthwhile component at all times.* 536 South Fair Oaks, Pasadena 1, Cal. SY 5-4118 RY 1-8171

## "EVERYTHING IN HIGH FIDELITY"

From Primary Components to Completed Custom Audio Equipment

**KIERULFF**

Sound Corp.

820 West Olympic Blvd. • Los Angeles 15, Calif. Richmond 7-0271 ZEnith 0271

## Custom-Built Equipment

## U. S. Recording Co.

1121 Vermont Ave., Washington 5, D. C. Lincoln 3-2705

## CANADA

### High Fidelity Equipment

Complete Lines • Complete Service  
HI-FI Records — Components and Accessories

**ELECTRO-VOICE SOUND SYSTEMS**

141 DUNDAS ST. WEST, TORONTO, CANADA.

## SPICES MAGNETIC TAPE

Neatly — Quickly — Easily

Kit includes plastic splicer which adheres to recorder or worktable, generous supply of pre-cut tape splicing tabs, handy blade, instructions and plastic case. Only \$1.50 postpaid. If your dealer can't supply you, order from . . .

**COUSINO, INC.**

2857 Madison Ave.

Telco 2, Ohio

NEW!

for everything in Electronics!

195 Sed.



1440 page MASTER

- Detailed specs • 8,500 illus.
- 85,000 items • Fully indexed
- Full descriptions • Wgt. 6 lbs.

At \$1.95 at most electronic parts low distributors. List \$6.50

UNITED CATALOG PUBLISHERS, INC., 110 Lafayette St., N. Y. 13

## Industry People...

**R. T. (Rudy) Bozak**, manufacturer of Bozak high-quality speakers, reports that increasing business has his company's new Darien, Conn., plant nearing capacity operation . . . **John J. O'Connor**, for many years one of Broadway's outstanding newspaper men, has been appointed editor-in-chief of "The Musician's Guide", the music industry's standard reference book . . . **Sol A. Cohen** has been named head of the technical publications group of the Instrumentation division of Ampex Corporation . . . **Dr. Donald B. Sinclair** has been appointed vice-president for engineering of General Radio Company—he joined the company in 1936, and since 1949 has been serving as chief engineer.

**Lawrence M. Heineman**, president of Permosflux Corporation, announces a new executive alignment aimed at "re-enforcing the management team." The new executive group consists of **R. S. Fenton**, vice-president in charge of sales and engineering; **Frank Newberg**, manager of manufacturing, and **Edward Watermuller**, administrative manager. Additional changes at Permosflux find **Sam Hyman**, formerly chief engineer, filling the newly-created position of chief commercial engineer, while the chief engineer's spot is taken over by **Walter Padgett**, formerly of Motorola and Raytheon.

**Kenneth S. Brock**, formerly sales and advertising manager for a number of prominent electronic manufacturing companies, has been named to that position with Browning Laboratories, Inc. . . . New executive appointments at Chicago's Allied Radio Corporation include **Stanley A. Baum**, who has been named comptroller; **Goodwin G. Mills**, manager of the electronic kit department, and **Leonard S. Preskill**, product development manager.

Newly-elected officers of the West Coast Electronic Manufacturers Association are: President, **H. Myrl Stearns**, executive vice-president of Varian Associates; vice-president, **Gramer Yarbrough**, assistant manager of the American Microphone Company; secretary, **D. C. Duncan**, vice-president of Helipot Corporation; Treasurer, **Calvin K. Townsend**, vice-president of Jennings Radio Manufacturing Company . . . **Dr. Vincent Salmon**, manager of Stanford Research Institute's sonic section, has been appointed editor of the "Journal of the Audio Engineering Society." He succeeds **Lewis S. Goodfriend** who is now editor of "Noise Control," a new journal published by the Acoustical Society of America.

**Harold R. Ellis**, general manager of British Electronic Sales Company, Long Island City, N. Y., has taken over national sales representation of the British-made B-J tone arm. Other products handled by the company are Partridge transformers, Painter attenuators, and Preh pads and mixers . . . This column hereby extends its apologies to **Lawrence Epstein**, sales manager of University Loudspeakers, Inc., for having turned his job over to **Irving Greene**, University's new advertising and sales promotion manager, in last month's report. Forgive?

C  
H  
A  
S  
I  
S



## CUSTOM-CONTRACT PRODUCTION

Anderson

Metal Products, Inc.  
Box 716, Brattleboro, Vt.

Now, try  
**FAIRCHILD'S**  
**new Series 220,**  
**and...**

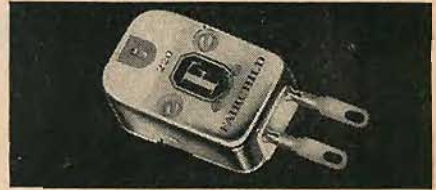

## Hear what you've been missing!

Only Fairchild's newly-improved *moving coil design* as featured in this brand new cartridge Series 220, can offer such outstanding performance. Only this amazingly accurate, high-compliance cartridge can bring your records to such full, dramatic life!

LOOK AT THIS  
FREQUENCY RESPONSE CURVE!

**\$37.50**

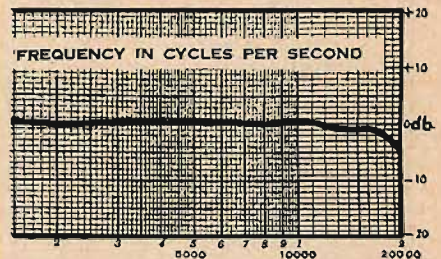

Virtually no distortion—uniform response up to 17,000 cycles, with slow roll-off beyond. No peaks or jagged response curves mean no rough sound or unnatural harshness.

And, a  
**perfect mate...**



## 280 Series Transcription Arm

Match your cartridge to the finest arm! Low-mass and resonance-free, Fairchild's 280 Transcription Arm allows the cartridge *alone* to lift all the tone color from your recordings. Superb precision balance and engineering assure perfect mid-groove tracking, always. And, any standard cartridge plugs in easily—performs better—with this versatile Fairchild 280!

**\$29.50**

**FAIRCHILD RECORDING EQUIPMENT**

9th AVE. & 154th ST., WHITESTONE, N. Y.

America's most complete line

# Carter ROTARY POWER SUPPLIES

## ROTARY POWER IS BEST

The "clap-clop" of "Old Bess" gave Grandma's buggy ride more vibration than the smooth Rotary Power of today's modern automobiles. ROTARY POWER is best for mobile radio, too . . . and for all DC to AC conversion . . . smoother . . . more dependable.



### DC TO AC CONVERTERS

For operating tape recorders, dictating machines, amplifiers and other 110-volt radio-

audio devices from DC or storage batteries. Used by broadcast studios, program producers, executives, salesmen and other "field workers".

### DUO-VOLT GENEMOTORS

The preferred power supply for 2-way mobile radio installations. Operates from either 6 or 12-volt batteries. Carter Genemotors are standard equipment in leading makes of auto, aircraft, railroad, utility and marine communications.



### CHANGE-A-VOLT DYNAMOTORS

Operates 6-volt mobile radio sets from 12-volt automobile batteries . . . also from 24, 32 and 64-volt battery power. One of many Carter Dynamotor models. Made by the world's largest, exclusive manufacturer of rotary power supplies.



### BE SAFE . . . BE SURE . . . BE SATISFIED

AC can be produced by reversing the flow of DC, like throwing a switch 120 times a second. But ROTARY converters actually generate AC voltage from an alternator, same as utility stations. That is why ROTARY power is such clean AC, so dependable . . . essential for hash-free operation of recorders from DC power.



MAIL COUPON for illustrated bulletin with complete mechanical and electrical specifications and performance charts. Carter Motor Co., Chicago 47.

CARTER MOTOR CO.  
2648 N. Maplewood Ave.  
Chicago 47, Illinois

Please send illustrated literature containing complete information on  Carter "Custom" Converters and  Dynamotor Power Supplies

NAME .....  
Address .....  
City ..... State .....

## ADVERTISING INDEX

Allied Radio Corp.	42
Altec Lansing Corporation	9
Ampex Corporation	Cover 2
Anderson Metal Products, Inc.	75
Arrow Audio Center	63, 69
Audak Co.	1C
Audiogersh Corporation	67

Belden Mfg. Co.	11
Bell Telephone Laboratories	16
Bogen, David, Co. Inc.	39
British Industries Corp.	3

Cabinart	8
Carter Motor Co.	76
Centralab, Division of Globe-Union	60
Classified Advertisements	74
Cousino, Inc.	75
Crestwood Tape Recorders	47

Duotone Co., Inc.	54
-------------------	----

Electro-Voice, Inc.	1, 33
Electro-Voice Sound Systems	75

Fairchild Recording Equipment Corp.	43, 75
-------------------------------------	--------

Goodmans Industries, Ltd.	Cover 3
General Electric Co.	35, 55

Harvey Radio Co., Inc.	49
Heath Co.	40
Hi-Fidelity Distributors, Inc.	52
High Fidelity House	75
Hollywood Electronics	75
Hughes Research and Development Laboratories	2
Hycor Co., Inc.	57

Interelectronics	12
------------------	----

Kierulff Sound Corporation	75
----------------------------	----

Leonard Radio, Inc.	51, 71
---------------------	--------

Marantz, S. B.	68
McIntosh Laboratory, Inc.	53
Measurements Corp.	62
Minnesota Mining and Mfg. Co.	13
Musical Masterpiece Society, Inc., The	66

National Company	56, 57, 58, 59
------------------	----------------

Partridge Transformers, Ltd.	66
Permoflux Corp.	41
Pickering & Company, Inc.	15
Pilot Radio Corp.	31
Presto Recording Corporation	37
Prestoseal Mfg. Co.	76
Professional Directory	75

Radio Shack Corporation	46
Rauland-Borg Corporation	50
Recoton Corporation	64
Reeves Soundcraft Corporation	5
Rek-O-Kut Company	6
Ronette Acoustical Corporation	70

Scott Radio Laboratories, Inc.	45
Shure Brothers, Inc.	4

Tech-Master Products Co.	68
Terminal Radio Corp.	73
Tetrad	7
Thorens Company	44

United Catalog Publishers, Inc.	75
United Transformer Co.	Cover 4
U. S. Recording Co.	75
University Loudspeakers, Inc.	61, 63, 65

Wiley, John & Sons, Inc.	72
White, Stan, Inc.	71

## NOW ON HAND

The New

MT-1M PRESTO-SPLICER  
for WELDING TOGETHER

1/4" MYLA and acetate tapes  
without cement or adhesives

- Diagonal cut capable of withstanding 3 pound pull
- Inaudible with playback amplifier gain at maximum



\$67 F.O.B. Factory

Sample splice and brochure on request.

**PRESTOSEAL** MFG. CORP.  
3727 33rd st., Long Island City 1, N.Y.



### ...before it TALKS

...is the way our doctors put it—"Our chances of curing cancer are so much better when we have an opportunity to detect it *before it talks.*"

That's why we urge you to have periodic health check-ups that *always* include a thorough examination of the skin, mouth, lungs and rectum and, in women, the breasts and generative tract. Very often doctors can detect cancer in these areas long before the patient has noticed any symptoms.

For more life-saving facts phone the American Cancer Society office nearest you, or write to "Cancer"—in care of your local Post Office.

American Cancer Society



**...BECAUSE  
THEY  
SOUND  
BETTER...**

Admittedly, the performance quality of a loudspeaker depends upon design and construction. But we know that you intend neither to design nor build one. You will select one already designed and built. And when you sit back to an evening of musical enjoyment, the chances are you won't be thinking of flux density, impedance or cone suspension.

Certainly, the facts and figures are available for

Goodmans High Fidelity Speakers...and we know they will impress you. But, the point we make is that you select *your* speaker as you intend to use it... not on paper but by critical listening. The more critical you are, the more confident are we that your choice will be Goodmans—for the best reason in the world—*because they sound better.*

*Complete Service Facilities maintained for your convenience*

Sold by Leading Sound Dealers • Prices Slightly Higher on West Coast

*For Complete Literature, write to:*

**ROCKBAR CORPORATION** 215 East 37th Street, New York 16, N. Y.



**AXIETTE**  
8-inch  
5 watts  
40-15,000 cps  
\$23.20

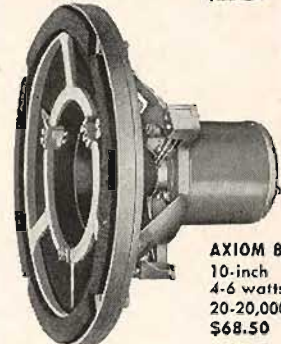

**AXIOM 80**  
10-inch  
4-6 watts  
20-20,000 cps  
\$68.50



**Mark II  
AXIOM 150**  
12-inch  
15 watts  
30-15,000 cps  
\$53.50

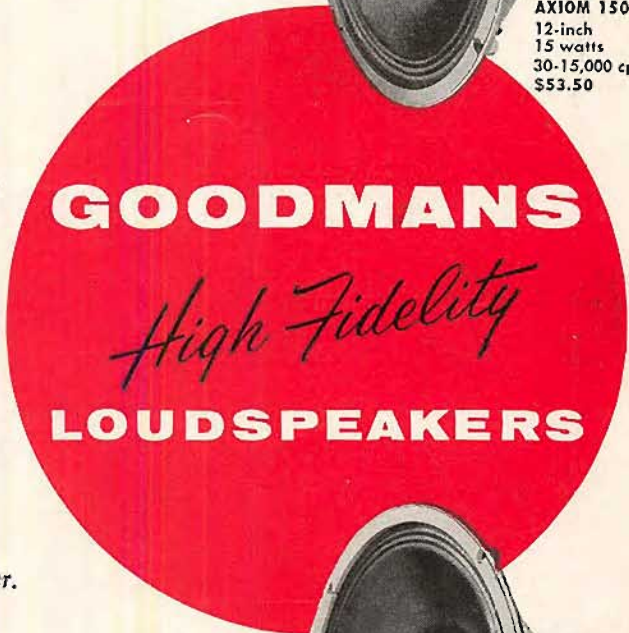

**Mark II  
AXIOM 22**  
12-inch  
20 watts  
30-15,000 cps  
\$72.95



LEADERS IN  
MINIATURIZATION  
FOR OVER  
TWENTY YEARS...



# MINIATURIZED TRANSFORMER COMPONENTS **FROM STOCK**

Items below and 650 others in our catalog A.

## HERMETIC SUB-MINIATURE AUDIO UNITS

These are the smallest hermetic audios made.

Dimensions . . . 1/2 x 11/16 x 29/32 . . . Weight .8 oz.



### TYPICAL ITEMS

Type No.	Application	MIL Type	Pri. Imp. Ohms	Sec. Imp. Ohms	DC in Pri MA	Response ±2 db (Cyc.)	Max. level dbm
H-30	Input to grid	TF1A10YY	50*	62,500	0	150-10,000	+13
H-31	Single plate to single grid, 3:1	TF1A15YY	10,000	90,000	0	300-10,000	+13
H-32	Single plate to line	TF1A13YY	10,000*	200	3	300-10,000	+13
H-33	Single plate to low impedance	TF1A13YY	30,000	50	1	300-10,000	+15
H-34	Single plate to low impedance	TF1A13YY	100,000	60	.5	300-10,000	+6
H-35	Reactor	TF1A20YY	100 Henries-0 DC, 50 Henries-1 Ma. DC, 4,400 ohms.				
H-36	Transistor Interstage	TF1A15YY	25,000	1,000	.5	300-10,000	+10

\*Can be used with higher source impedances, with corresponding reduction in frequency range and current

## COMPACT HERMETIC AUDIO FILTERS



UTC standardized filters are for low pass, high pass; and band pass application in both inter-stage and line impedance designs. Thirty four stock values, others to order. Case 1-3/16 x 1-11/16 x 1-5/8 - 2-1/2 high . . . Weight 6-9 oz.

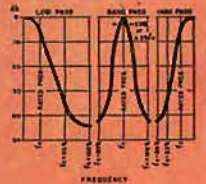

## HERMETIC MINIATURE HI-Q TOROIDS

MQE units provide high Q, excellent stability and minimum hum pickup in a case only. 1/2 x 1-1/16 x 17/32 . . . weight 1.5 oz.



### TYPICAL ITEMS

Type No.	Inductance	DC Max.
MQE-1	7 mhy.	135
MQE-3	20 mhy.	80
MQE-5	50 mhy.	50
MQE-7	100 mhy.	35
MQE-10	.4 hy.	17
MQE-12	.3 hy.	12
MQE-15	2.5 hy.	7

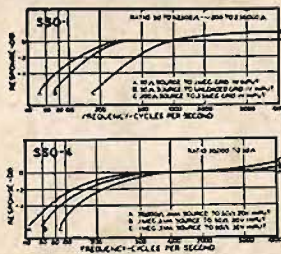
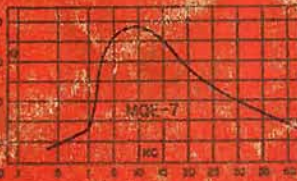

## SUB-SUBOUNCER AUDIO UNITS

UTC Subouncer and sub-subouncer units provide exceptional efficiency and frequency range in miniature size. Constructional details assure maximum reliability. SSO units are 7/16 x 3/4 x 43/64 . . . Weight 1/50 lb.



Type	Application	Level	Pri. Imp.	MA D.C. In Pri.	Sec. Imp.	Pri. Res.	Sec. Res.
*SSO-1	Input	+ 4 V.U.	200 50	0	250,000 62,500	13.5	3700
SSO-2	Interstage /3:1	+ 4 V.U.	10,000	0-.25	90,000	750	3250
*SSO-3	Plate to Line	+20 V.U.	10,000 25,000	3 1.5	200 500	2600	35
SSO-4	Output	+20 V.U.	30,000	1.0	50	2875	4.6
SSO-5	Reactor 50 HY at 1 mil. D.C. 4400 ohms D.C. Res.						
SSO-6	Output	+20 V.U.	100,000	.5	60	4700	3.3
*SSO-7	Transistor Interstage	+10 V.U.	20,000 30,000	.5 .5	800 1,200	850	125

\* Impedance ratio is fixed, 1250:1 for SSO-1, 1:50 for SSO-3. Any impedance between the values shown may be employed.

## SUBOUNCER (WIDE RANGE) AUDIO UNITS

Standard for the industry for 15 yrs., these units provide 30-20,000 cycle response in a case 7/8 dia. x 1-3/16 high. Weight 1 oz.



### TYPICAL ITEMS

Type No.	Application	Pri. Imp	Sec. Imp
0-1	Mike, pickup or line to 1 grid	50, 200/250, 500/600	50,000
0-4	Single plate to 1 grid	15,000	60,000
0-7	Single plate to 2 grids, D.C. in Pri.	15,000	95,000
0-9	Single plate to line, D.C. in Pri.	15,000	50, 200/250, 500/600
0-10	Push pull plates to line	30,000 ohms plate to plate	50, 200/250, 500/600
0-12	Mixing and matching	50, 200/250	50, 200/250, 500/600
0-13	Reactor, 300 Hys.—no D.C.; 50 Hys.—3 MA. D.C., 6000 ohms		

## HERMETIC VARIABLE INDUCTORS



These inductors provide high Q from 50 - 10,000 cycles with exceptional stability. Wide inductance range (10 - 1) in an extremely compact case 25/32 x 1-1/8 x 1-3/16 . . . Weight 2 oz.

### TYPICAL ITEMS

TYPE No.	Min. Hys.	Mean Hys.	Max. Hys.	DC Ma
HVC-1	.002	.006	.02	100
HVC-3	.011	.040	.11	40
HVC-5	.07	.25	.7	20
HVC-6	.2	.6	2	15
HVC-10	7.0	25	70	3.5
HVC-12	50	150	500	1.5

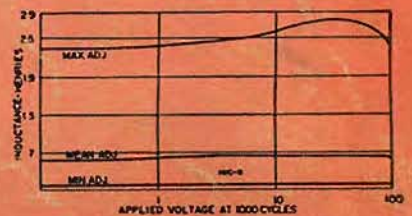
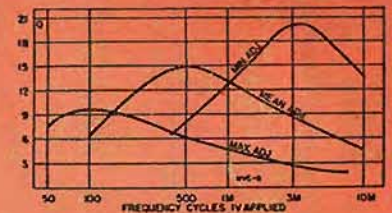

LET US MINIATURIZE YOUR GEAR.

SEND DETAILS OF YOUR NEEDS for SIZES and PRICES

# UNITED TRANSFORMER CO.

150 Varick Street, New York 13, N. Y. • EXPORT DIVISION: 13 E. 40th St., New York 16, N. Y.

CABLES: "ARLAB"