

# dB

THE SOUND ENGINEERING MAGAZINE

APRIL 1968 75¢

Complete Guide to the West Coast AES Convention  
Make-It-Yourself Circuit Boards  
Movie Theater Sound Systems

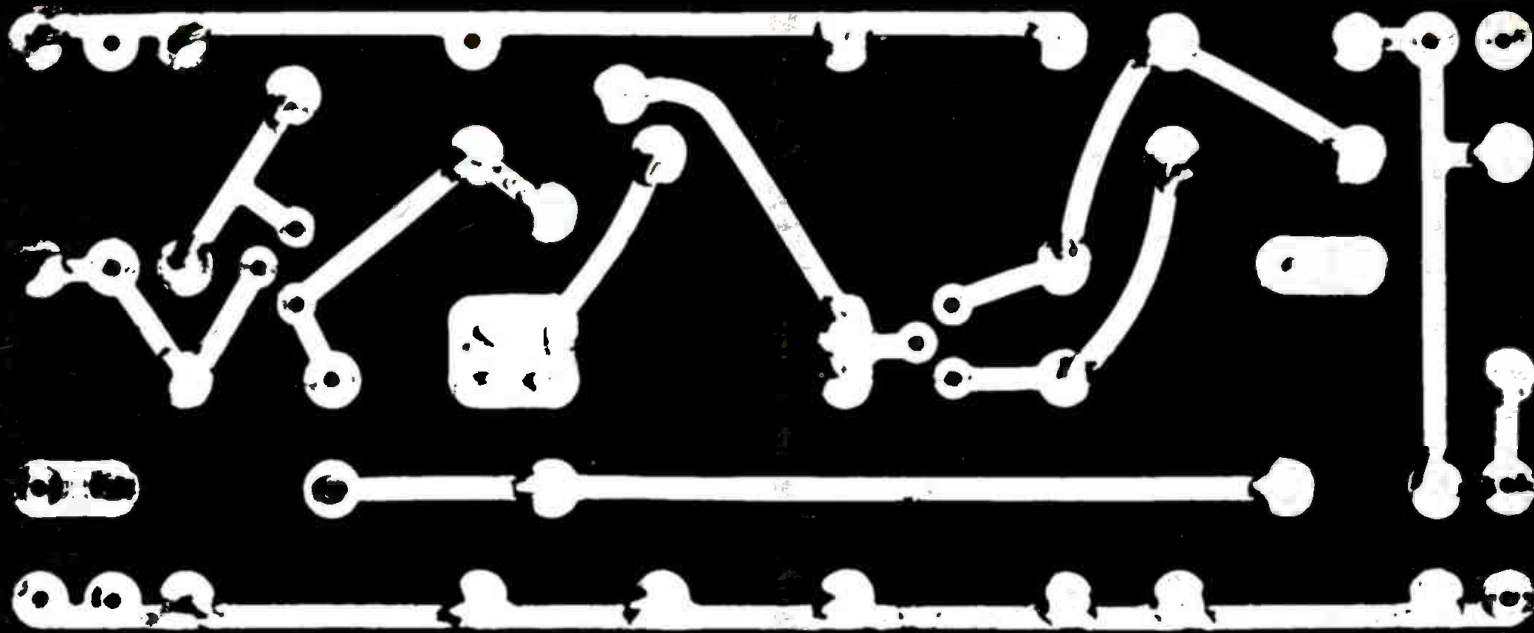

ALBERT B GRUNDY JR  
INTERNATL ELECT INC  
333 6TH AVE  
NEW YORK N Y 10014

# There are 50 sound reasons why you should look to FAIRCHILD for Professional Audio Components...

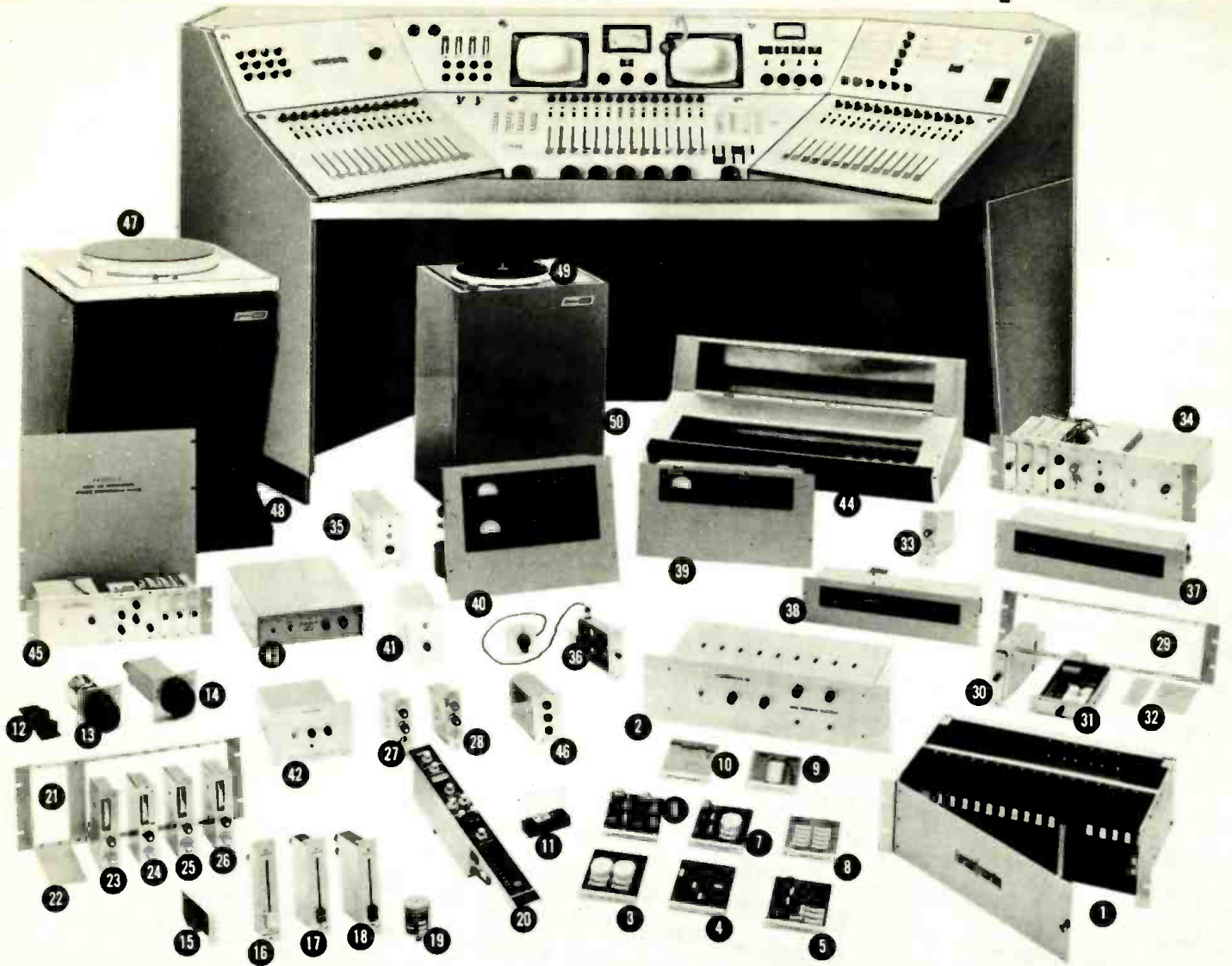

and here they are!...

- |   |   |   |
|---|---|---|
| <ol style="list-style-type: none"> <li>1. Integra I Card Cage (692 RM)</li> <li>2. Integra II Power Supply (624)</li> <li>3. Double Remote Attenuator Card (692 D/2)</li> <li>4. Remote Compressor Card (692 AGC)</li> <li>5. Remote Equalizer Card (692 EQ)</li> <li>6. Double Preamp Card (692 AD/TX1)</li> <li>7. Preamp, Remote Attenuator, Relay &amp; Mix. Net. Card (692)</li> <li>8. Ten SPST Relays with Mix Net Card (692 SW-10)</li> <li>9. Five DPST Relays with Mix Net Card (692 SW-5)</li> <li>10. Mixing Network (692 MX)</li> <li>11. Mono Cartridge (225-A)</li> <li>12. Remote Stereo Board (669 ST)</li> <li>13. Rotary Attenuator (669 II)</li> <li>14. Rotary Stereo Attenuator (669 ST)</li> <li>15. Remote Attenuator Board (668 RAB)</li> <li>16. Slide Actuator (668 ACT II)</li> <li>17. Slide Attenuator (668 II)</li> <li>18. Slide Stereo Attenuator (668 ST II)</li> </ol> | <ol style="list-style-type: none"> <li>19. Remote Attenuation Cell (668 RAC)</li> <li>20. Integrated Mixer Control Module with EQ, AGC, and other features (FICM)</li> <li>21. Rack Frame (663 RM)</li> <li>22. Blank Plate (663 BP)</li> <li>23. De-Esser (675)</li> <li>24. Ambient Noise Control Unit (653)</li> <li>25. Dynalizer, Automatic Loudness Control (673)</li> <li>26. Compact Compressor (663)</li> <li>27. Passive Program Equalizer (664)</li> <li>28. No Loss PGM Equalizer (664 NL)</li> <li>29. Rack Mtg Frame (662 RM)</li> <li>30. Preamp, Line Amp (662)</li> <li>31. Preamp, with 2 Remote Attenuators (692)</li> <li>32. Blank Plate (662 BP)</li> <li>33. Autoten, Signal Controlled Switch (661TL)</li> <li>34. Industrial "Handoff" Gain Shift Inter-com Electronics</li> </ol> | <ol style="list-style-type: none"> <li>35. 10-Watt Monitor Amp (610)</li> <li>36. Phono Equalized Preamp with HF. Equalizer (676 A/RO)</li> <li>37. Single Channel HF. Limiter, Conax (600)</li> <li>38. Stereo Conax (602)</li> <li>39. Mono Limiter (660)</li> <li>40. Stereo Limiter with Matrixing (670)</li> <li>41. 100 MA Power Supply (667 B)</li> <li>42. 6.3V 3A DC Regulated Power Supply</li> <li>43. 24V 2A DC Regulated Power Supply</li> <li>44. Custom Shell for Mixing Console</li> <li>45. Reverberation Device, Complete (658 A)</li> <li>46. Reverberation Generator (658 B)</li> <li>47. 16" Professional Turntable 2 and 3 spd. (750)</li> <li>48. Turntable Base (751)</li> <li>49. 12" 2-speed Turntable (755)</li> <li>50. Turntable Base (756)</li> </ol> |
|---|---|---|

... AND MANY OTHERS!

Write to FAIRCHILD — the pacemaker in professional audio products — for complete details.

**FAIRCHILD RECORDING EQUIPMENT CORP.**  
 10-40 45TH AVENUE • LONG ISLAND CITY,  
 NEW YORK 11101 • PHONE (212) 784-6163

Circle 10 on Reader Service Card

Coming  
Next  
Month

● May will feature the second part of David L. Klepper's ARCHITECTURAL ACOUSTICS. *Sound System Design* is the theme of this installment. Basic conditions to be covered include the providing of a proper acoustic match to the room acoustics, insuring a correct signal flow, and satisfactory appearance.

*Why Do We Hear What We Hear* was the title of a panel presentation sponsored by the New York AES earlier this year. A transcript of this most meaningful discussion will be featured.

A large part of the vast NAB convention is relevant to the professional audio field. Our roving camera covered the Chicago forum.

Plus our regular columnists and features. Don't miss the May issue of *db*, the *Sound Engineering Magazine*.

About  
the  
Cover



● Printed circuits are easy to make. The illustration above shows a more normal view of the board pictured on our cover.

db

THE SOUND ENGINEERING MAGAZINE

April 1968 • Volume 2, Number 4

## Table of Contents

### FEATURE ARTICLES

- Making a Printed-Circuit Board  
*Richard L. Lerner* 16
- The Contributions of Edsel Murphy  
*D. L. Klipstein* 20
- Motion-Picture Sound Systems  
*L. A. Wortman* 22
- The 34th AES Convention—Schedules and Locations 25

### MONTHLY DEPARTMENTS

- Letters 2
- The Feedback Loop  
*John A. McCulloch* 4
- The Audio Engineer's Handbook  
*George Alexandrovich* 6
- Theory and Practice  
*Norman H. Crowhurst* 10
- Sound With Images  
*Martin Dickstein* 12
- Editorial 15
- New Products and Services 29
- Classified 31
- People, Places, Happenings 32

### EDITORIAL BOARD OF REVIEW

George Alexandrovich  
Sherman Fairchild  
Norman Anderson  
Prof. Latif Jiji  
Philip C. Erhorn  
Daniel R. von Recklinghausen  
Paul Weathers

*db*, the *Sound Engineering Magazine* is published monthly by Sagamore Publishing Co., Inc. Entire contents copyright © 1968 by Sagamore Publishing Co., Inc., 980 Old Country Road, Plainview, L. I., N.Y. 11803. Telephone: (516) 433-6530. Subscriptions are issued to qualified individuals and firms in professional audio. Application must be made on an official subscription form or on a company letterhead. Interested non-qualified readers may subscribe at \$6.00 per year (\$7.00 per year outside U.S. Possessions, Canada, and Mexico). Single copies are 75¢ each. Controlled circulation rates paid at N. Abington, Mass. 02351. Printed in U.S.A. at North Abington, Mass. Editorial, Publishing, and Sales Offices: 980 Old Country Road, Plainview, New York 11803. Postmaster: Form 3579 should be sent to above address.

**Robert Bach**  
PUBLISHER

**Larry Zide**  
EDITOR

**Bob Laurie**  
ART DIRECTOR

**Marilyn Gold**  
COPY EDITOR

**Charles N. Wilson**  
ASSISTANT EDITOR

**Richard L. Lerner**  
ASSISTANT EDITOR

**A. F. Gordon**  
CIRCULATION MANAGER

**David Pollens**  
ASST. CIRCULATION MGR.

### SALES OFFICES

#### New York

980 Old Country Road  
Plainview, N.Y. 11803  
516-433-6530

#### Chicago

Gerald L. Taylor  
333 N. Michigan Ave.  
Chicago, Illinois 60601  
312-332-7683

#### Denver

Roy McDonald Associates, Inc.  
846 Lincoln Street  
Denver, Colorado 80203  
303-825-3325

#### Houston

Roy McDonald Associates, Inc.  
3130 Southwest Freeway  
Houston, Texas 77006  
713-529-6711

#### Tulsa

Roy McDonald Associates, Inc.  
2570 S. Harvard Ave.  
Tulsa, Oklahoma 74114  
918-742-9961

#### Dallas

Roy McDonald Associates, Inc.  
Semmons Tower West  
Suite 411  
Dallas, Texas 75207  
214-637-2444

#### San Francisco

Roy McDonald Associates, Inc.  
625 Market Street  
San Francisco, California 94105  
415-397-5377

#### Los Angeles

Roy McDonald Associates, Inc.  
1313 West 8th Street  
Los Angeles, California 90017  
213-483-1304

#### Portland

Roy McDonald Associates, Inc.  
2035 S.W. 58th Avenue  
Portland, Oregon 97221  
503-292-8521

# Letters

The Editor:

First, allow me to add my congratulations to the many you have already received for a fine publication. I have not as yet run across an article which has not interested me and which I do not want for future reference. Please pass along a special note of appreciation to Albert B. Grundy for his article *European Condenser Microphone Specifications*, and thank you for publishing the article.

*Don Paches*  
Edmonton, Alberta, Canada

The Editor:

In your February issue, under the heading *The Audio Engineer's Handbook* by Mr. George Alexandrovich, there is a small error which I wish to correct.

The Ortofon stereo cutter is *not* a lateral-vertical cutter, but a 45-45 system. The vertical coil arrangement over a virtual pivot might lead one astray at first sight, but in effect, the operation of the Ortofon cutter is identical with the Westrex method.

*Claude L. Rie*  
International Recording Co.  
Ortofon Professional  
Recording Products

As the distributor of Ortofon's cutters, Mr. Rie certainly should know. George Alexandrovich concedes he was led astray.

Another gremlin crept into the February column, disrupting the illustration comparing cutting systems. See below.

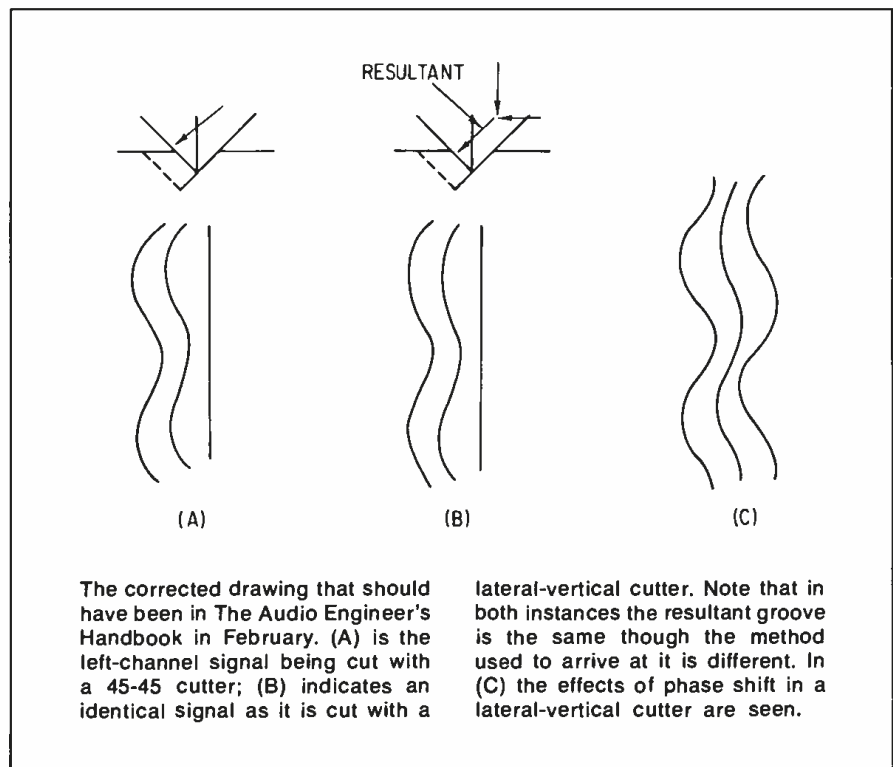

# Don't drop this amplifier into your coffee.

It may look like a sugar cube, but it tastes like an amplifier.

An operational amplifier to be specific. One of the many at Harvey's. And despite its tiny size, it's a no-compromise piece of equipment with low noise and low distortion.

The audio field, in general, will probably be seeing a lot of these sugar cube amplifiers in months and years to come. But Harvey's customers have had a taste of them for some time already.

The product specialists at Harvey's have been recommending and using these operational amplifiers as a matter of course lately.

And Harvey's has been making available and recommending a lot of other fantastic products of miniaturization too.

The new FET limiters, for example. In addition to being ultra-compact, they're also ultra-fast with ultra-low distortion. And although they're not exactly ultra-cheap, we bet they cost a lot less money than you're probably afraid you'd have to spend.

And we've got the new FET condenser microphones. And all the new tape recording equipment you've been reading about.

(Harvey's is prepared to supply you with complete 24-track tape set-ups, high-speed duplicators, and packaging equipment for cassettes and cartridges faster than you can decide where you're going to put them.)

Call Harvey's often. And if you're not already on our mailing list, get on it.

Harvey's can keep you in touch with products so new, you may find some of them a bit hard to swallow.

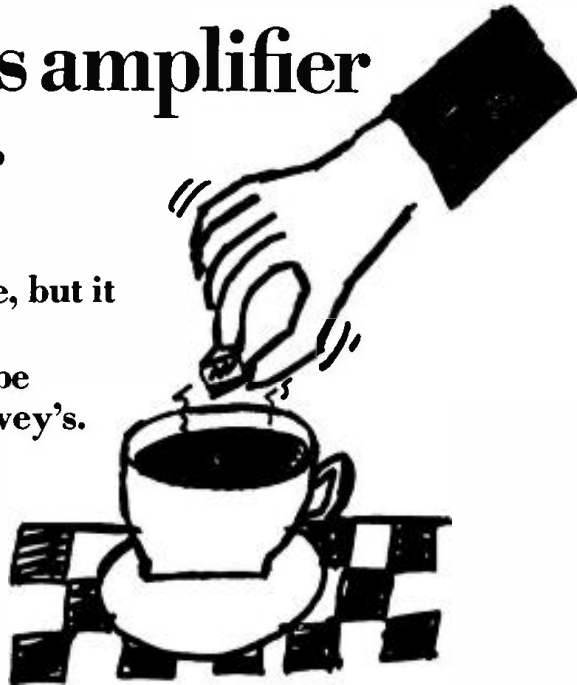

## Harvey Radio Co., Inc.

Professional A/V Division, 2 West 45th St., New York, N.Y. 10036 (212) JU 2-1500

Circle 13 on Reader Service Card

# The Feedback Loop

JOHN A. McCULLOCH

The Feedback Loop invites your questions on any subject pertinent to professional audio. Address your queries to THE FEEDBACK LOOP, db Magazine, 980 Old Country Road, Plainview, N.Y. 11803. Please enclose a stamped, self-addressed envelope. Mr. McCulloch will answer all letters in this column or by mail.

● Every day we hold two-way conversations over telephones. Radio and television program requirements often call for such conversations to be used for broadcast. Mr. John P. Laughlin of WBLT has such a requirement, and in answer we turned to ABC-Hollywood's engineering maintenance department, and Mr. Nick Punt.

ABC's local station had a program in which the hostess conversed in the studio with her guests. At selected intervals she also spoke via telephone with others outside the studio. It was desired that the system provide maximum quality and flexibility. Her voice was to remain constant, whether on or off the telephone line. Also the person at the non-studio end of the phone had to hear the voice of the hostess.

A basic make-do circuit was designed and utilized to enable the program to begin, while studies were carried out to determine a simpler and easier-to-

operate circuit. The circuit shown in FIGURE 1 is the result.

The hostess microphone is amplified, controlled, and muted. One feed is sent directly through the board. The second goes through an additional control and is amplified and fed to the telephone line through a hybrid transformer. The circuit provides for two incoming telephone lines to be switched into the network. A standard handset is also connected to the lines at the telephone company's terminal board to receive the calls and hold the line until it is used on the air. The second feed from the hybrid feeds the telephone conversation to the program line. Bridged from the coil are feeds to the audience and other in-studio guests, and to the hostess — via a separate headpiece. This separate headpiece can also be used to give the hostess cueing instructions.

The telephone company supplied the beeper system. The feeds to the studio were at 0 dBm — 600 ohms. Termination was provided internally in the beeper. For direct reception only, a simple matching or bridging transformer is the only requirement.

Utilizing a tap from a local handset and attempting to pick up both sides of the conversation does not prove effective, because the balance of levels cannot be accurately controlled. Direct reception is best limited to news reception and requests, when only the calling voice is picked up from the phone line.

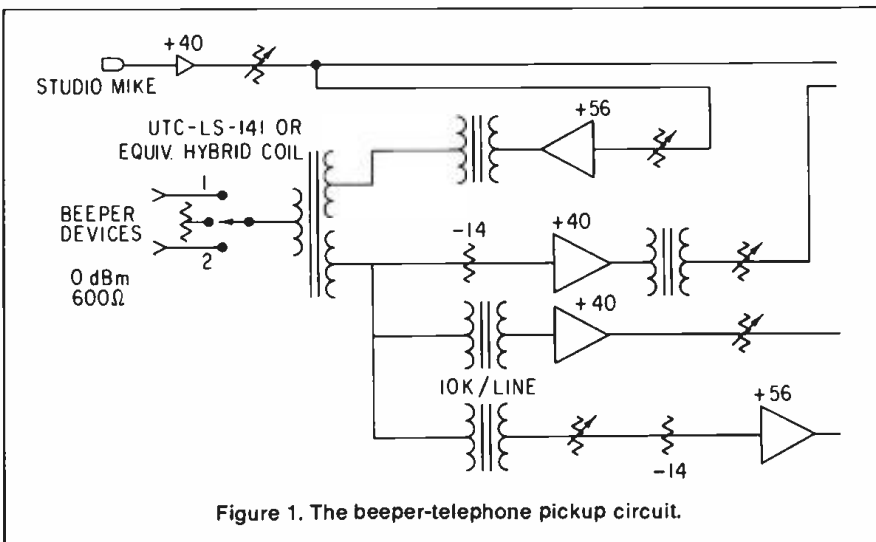

Figure 1. The beeper-telephone pickup circuit.

A letter from Mr. Jerry Lamb of KGME reminds me of the time not so many years ago when I was looking for a school to give me the basics of the radio, tv and the recording business. There were several schools for d.j.'s, and others for maintenance men. But there was no place where a good understanding of studio techniques could be had. Mr. Lamb is not alone in trying to find an education in this business, and certainly in the near future, if not today, the industry is going to need young people.

For that reason I am asking all the readers of db to let me know if they know of a school offering a thorough course in the mechanics of the industry. I will contact the schools; those offering this education will be forwarded to such inquiries as Mr. Lamb's.

Specifically, such a course might include technical instruction, preferably including a 1st ticket, microphone technique, console operation, production technique, tape editing, disc cutting, and general mixing critique. Such a list is of course only basic, and must skim the areas of knowledge that make a man knowledgeable in this industry.

A seminar held last year at Brigham Young University, and planned for early August this year, attempted to cover in review the major areas of interest in recording. But even at a full eight hours each day, five days may only touch on the highlights or cover one small area. It is, however, a good start. Sufficient response and interest may cause educators to look at their programs of education pertaining to the industry, and broaden their scope. Why not a major in Electrical Engineering with a minor in Broadcasting? How many of you are looking for a young man to fill out your staff? How many times must you settle for someone who knows some of the areas and hope that he can 'pick up' the rest necessary to become valuable to your team?

Finally, lacking formal educational facilities, are any of the studios engaged (or interested) in training young men to fill the vacancies now existing and the many more openings coming in the future?

## Moving?

Have you sent us a change-of-address notice? It takes time for us to change your plate so let us know well in advance of your move. Be sure to send us the complete new address *as well as your old address*. Include both zip numbers. Keep db coming without interruption!

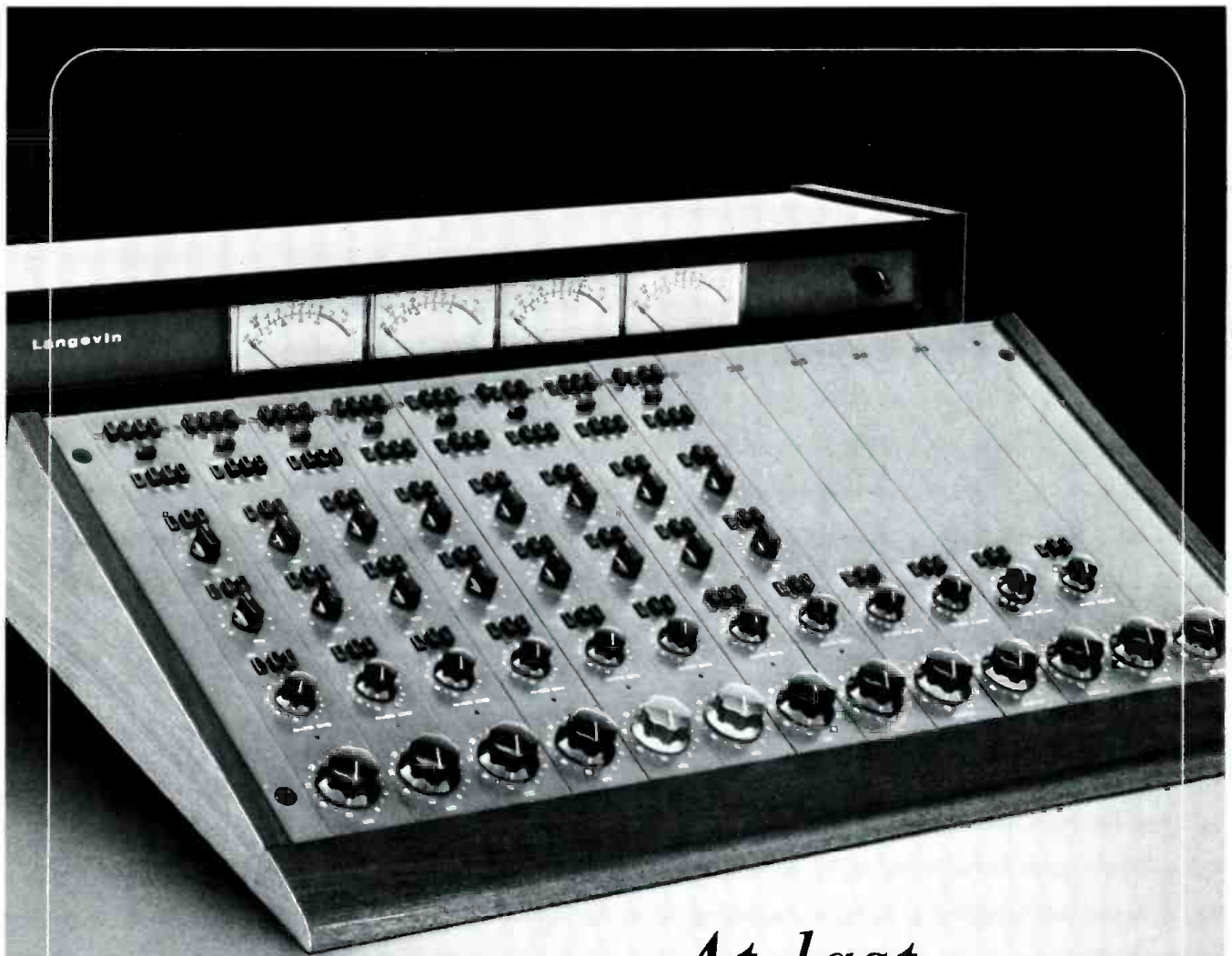

Langevin's new AM4A is a revolutionary concept in audio mixers... a fully integrated system that is completely wired, tested and checked out. Just open the box, connect the input/output lines, drop in the modules and you're ready to go. No wiring, no engineering headaches. **How's that for openers?**

Completely flexible in application, you buy only what you need. Later, as your requirements change, you can expand or modify your AM4A by dropping in new modules. It's that easy.

Designed to Langevin's rigid professional standards, the AM4A can be used in recording studios, churches, auditoriums or even hand carried to special recording or broadcast locations. A typical AM4A with 4 output channels will mix and match the inputs of up to 15 microphones, controlling HF and LF equalization, solo, reverb and mix... 1 thru 4 channels.

Prices start at less than \$3,000, one-half the cost of comparable mixers. And, if you're a qualified customer, you can try an AM4A on a free 30-day trial. **How's that for a closer.**

*At last...*  
an audio  
mixer for  
the man  
who doesn't  
want to do it  
himself!



**Langevin**

1801 East Carnegie Avenue Santa Ana, California 92705 (714) 546-8330

Circle 14 on Reader Service Card

# The Audio Engineer's Handbook

—GEORGE ALEXANDROVICH

## Disc Cutting *continued*

### Suction, Heat, and Lacquer Noise

● The reason for discussing all three of these subjects together is because they are closely inter-related. The lowest groove noise is achieved with a proper amount of heat applied to the stylus tip. The amount of heat is, in part, a function of the amount of suction. It is the adjustment of these variables that is the subject at hand.

First, the amount of suction must be adjusted so that the chip is properly picked up. This is controlled by varying the speed of the suction pump or by changing the vent opening of the suction pipe. The first choice is more desirable since it also reduces the airborne noise which may interfere with monitoring.

An ordinary vacuum cleaner is the most popular (and least expensive) way of obtaining the needed vacuum. Some studios prefer using a Variac to reduce power to the vacuum. There is yet another simple and effective means to reduce voltage if you lack a variable transformer.

Take an ordinary lamp with several sockets and install high-wattage bulbs. By varying the number of bulbs connected with the lamp in series with the motor, the speed will be reduced. A considerable degree of sophistication can be achieved by connecting the bulbs through switches so that higher vacuum speeds can be used for lead-in grooves, with a lower vacuum easily switched in for program modulation.

Proper amounts of suction are important because excessive suction will cause groove noise due to the rushing air modulating the cutting stylus. So the position of the suction pipe must be such that the chip is picked up easily without causing air modulation of the stylus. Proper positions can often be determined experimentally. Usually, it

is found to be almost behind the cutting stylus.

The amount of stylus heat should be adjusted with the suction at its minimum-use setting. (Some lathes (such as Scully) feature automatic increases in suction during the lead-in spiral.) With the heat set for a minimum-suction condition the stylus will not be subject to overheating conditions.

Different lacquer batches may require different amounts of heat to achieve the lowest surface noise. The best way to adjust heat is to use a pickup arm mounted on the lathe so that the groove may be monitored directly after it is cut.

Cut a groove without any modulation. (Turn off the recording amplifier.) With a meter monitoring the playback pickup's amplifier, observe the noise level. Gradually increase the current through the heater. As the heat rises, the noise will be reduced. After a point it will begin to rise again. Back up the setting until the minimum heat for the lowest noise is determined. Note the amount of current and suction being used. Any change of suction will require a resetting of the heater current (except for the lead-in groove) where an increase in noise is tolerable.

Approximate heater settings can be made by adjusting the current until the wires leading to the heater just glow red. The measured current through the heater may be anywhere from 0.5 to 1 amp—depending on the suction.

It's worthy of note that the *type* of current may be important. Some cutters are sensitive to a.c. heaters because the feedback coils may pick up 60 Hz hum. For these cutters, of course, d.c. must be used.

I must warn that heat should not be set without suction operating. The flow of air around the stylus changes the heat.

Another warning: excessive heat produces a deeper groove at smaller radii. In extreme cases, lacquer may

burn and stick to the stylus forming a hard shell around it. If you have been discarding styli because of this, some paint remover, epoxy solvent, or household cleaner will remove the residue. After applying the chemical to the stylus, wipe it off with a soft rag. Don't apply the solvent to the stylus shank.

Overheated chips often clog the suction passages. As a cure, place a little talcum powder on a piece of paper and let the suction hose pick it up. This will make the walls of the pipe non-sticky; this is particularly effective on highly humid days.

If acetone or other solvents are used to clean the stylus and advance ball, be sure none of the liquid finds its way onto the cutter coils or into its interior. This is an all too common cause of burned-out windings, stripped insulation, and damaged damping.

Another cause of coil burnouts is oil that is accidentally spilled on the cutter from the oil dash pot that is just above it. Oil seeps into the gaps between the coils and the pole pieces, restricting the motion of the armature. Feedback tries to correct this by sending a stronger signal into the coil, causing overheating of the winding and eventual burnout. (This condition does not exist in moving-iron cutters where the gaps are intentionally filled with oil for damping—and no tight feedback exists.)

Steel or magnetic filings can cause the same damage—only faster. So demagnetize and carefully wipe all screwdrivers and tweezers before bringing them close to the cutterhead.

### Recording Amplifiers

The amplifiers used to drive cutters are still mostly tube-type. With present-day recording techniques, at least 100 watts/channel are needed. Although recently developed transistor amplifiers can deliver such power, the fact remains that most of the units in present use operate with tubes.

Most of these amplifiers contain pre-equalization circuits as well as feedback monitoring facilities. Because of

### A Post Office Directive

requires that all periodicals must be addressed including a zip code. This means—no zip code, no delivery. Please be sure that all correspondence regarding your subscription includes that zip number.





*Crown Leadership presents the*



**MODEL CX 822**

For the studio where flexibility means creative productions.



**MODEL CI 844**

Four channel recorder for perfect mastering.

# NEW

## Computer Logic Control Pro 800 Transport

In the league of nimble-fingered tape-handlers there exists a recurrent problem. It has been demonstrated time and again that anyone can ruin a valuable tape by absentmindedly outsmarting the interlock system of an otherwise safe tape recorder.

In answer to this problem and similar problems arising in automated and remote control applications, the *CROWN Pro 800* was designed. This recorder has a computer logic system using IC's which prohibit all such destructive operations.

The CROWN computer stores the last command given it in its memory (forgetting all previous commands) and by a continuous knowledge of the operating state of the machine (motion and direction), it takes all the necessary measures and executes the command. This is all done *without* time-wasting delay mechanisms.

Computer logic control brings to you rapid error-free tape handling. It is actually impossible to accidentally break a tape. Call your CROWN dealer NOW!

### MOST PERFECT REPRODUCTION

- ☞ Performance as yet unequalled
- ☞ Four years proven Solid State circuitry
- ☞ Extremely low noise electronics

### FINEST TAPE HANDLING

- ☞ Computer smooth operation
- ☞ True straight line threading
- ☞ Patented Electro-Magnetic brakes never need adjusting

**THE HALLMARK OF CROWN — QUALITY CRAFTSMANSHIP THROUGHOUT**

**MADE  
ONLY  
IN  
AMERICA**

*Crown*

BOX 1000, ELKHART, INDIANA 46514 • PHONE (219) 523-4919

Circle 15 on Reader Service Card

the nature of cutter construction and response (just as with all mechanical transducers) phase reversal of the signal with multiple resonances is occurring over the audio spectrum. Motional feedback has the designation of flattening the response of the cutter by feeding the information back to the driver amplifier with inverse phase (negative feedback). At those frequencies where resonances occur, phase changes its sign and feedback may become positive instead of negative. At the higher frequencies, it becomes harder to prevent feedback from becoming positive as well as stopping excessive amounts of it from causing oscillation. As a result, the response of the feedback is restricted to those frequencies where it can be effectively controlled.

There is yet another aspect of feedback control of the cutter armature that restricts the usefulness of feedback. This is the relatively non-dependable coupling of the driving mechanism (coils) to the stylus. Since sensing for the feedback is usually done as close as possible to the cutting stylus (further away from the coils) tight coupling and steady phase relationships between the stylus-feedback system and the coils is not feasible.

In sum, feedback at the lower frequencies is an almost exact replica of the stylus motion; at higher frequencies feedback data (as well as compensation) is only as good as the feedback-sensing coupling to the stylus.

A sure way of determining the faithfulness of feedback is to feedback monitor the system, record the same signal, and compare the two. If they differ, then necessary compensation has to be applied and feedback monitoring must be restricted to reference use only.

Of course, the best monitoring is the playing of the disc itself. But for reasons of groove preservation for plating and stamping, it is bad policy to test play masters, even with the most compliant of cartridges. If you make an extra copy for quality testing, remember that high frequencies will sound duller on the lacquer than they will on vinyl pressings. This phenomenon occurs because the mechanical compliance of the lacquer groove is higher than one of vinyl. So the playback stylus tends to deform high-frequency excursions in the lacquer while vinyl will offer much more resistance to deformation.

### Amplifier Care

Since most of the driver amplifiers are still tube-types, preventive maintenance is absolutely necessary to keep the system working at its peak. The most likely trouble spots are the tubes and the electrolytics. Just as tubes must be periodically replaced so must the electrolytics. When a electrolytic loses its capacitance there is a decrease of power output along with an increase in distortion and hum level. If the capacitor in question happens to be a cathode bypass device, it may cause excessive rolloff at the low frequencies.

Therefore, periodic checks of the amplifier for maximum power at rated distortion, along with frequency response and noise measurements should be done (at least semi-annually). Remember that only a 3 dB drop of output level at the specified distortion reduces the amplifier's power in half. More than once, I have seen amplifiers in for "repair" when the only fault was a need for fresh tubes. Yet this work had not been done by the studio's maintenance crew.

Many studios leave their equipment on all day, regardless of room temperature. True, the system should be preheated prior to cutting to eliminate all thermal drifts that occur during warm-up. However, output tubes are limited in life and expensive in high-power amplifiers. It has been my experience that turning equipment on a half hour prior to cutting is quite sufficient to stabilize the circuits. This will also considerably prolong the life of the tubes.

Of course, the new transistorized amplifiers do not have to be turned on in advance since preheating is not needed.

### Half Speed Cutting

There are a number of tricks used by recording engineers to put higher levels on a disc than the cutter will normally allow. One of these is cutting at half the normal speed. Of course, the master tape is also fed in at half the speed. With this method, frequencies are halved; 10 kHz becomes 5 kHz. Because of preemphasis, lower frequencies are easier to record. This is the basis for achieving higher amplitudes.

But watch out for pitfalls. 30 Hz becomes 15 Hz. The playback equalization of the tape machine and of the recording amplifier have not been al-

tered although frequencies have changed. At these reduced speeds, the equalization crossover points must be adjusted if flat response is to be maintained. To determine the exact extent of needed modification, take a standard alignment/response tape and record it on disc — all at half speed. (Reduce the recording level at least 10 dB to protect the cutter.) Play the recording on a calibrated playback system noting the deviations. Inadequacies in the response can be corrected by using a program equalizer. This method works well with all equipment but is best with the newest direct-coupled (extended l.f. response) transistor amplifiers.

Reduced-speed cutting is particularly useful when test records or high-frequency tones must be recorded. Attempts to cut 20 kHz directly will prove to be impossible. At half speed, the problem is eliminated.

### "Toy" Recordings

The toy industry has created a large demand for small-sized, vertically-modulated discs. These records must be run at fairly high r.p.m. because of their small diameter, producing linear speeds of 5-15 in./sec. (Diameters range from 2½-5 inches.)

But the most intricate part of the requirement is that the disc be cut with multiple parallel grooves. Although each message may be only a few seconds, there may be as many as fifteen messages. Needless to say, this job requires patience, experimentation, and is tricky. An oversize blank should be used, offering a chance to start the cut well outside the prescribed maximum diameter and to adjust the relative position of the groove with the spiraling mechanism. By the time the cut reaches the diameter needed it is positioned exactly where it should be relative to the previous cut.

There is one condition that must be observed. Once you decide upon a pitch — *don't change it.*

A stereo cutter is used, strapped for vertical cutting by paralleling both channels with one of them 180-degrees out of phase with the other. The job can be made easier if a means is devised to start the recorder when the cutter reaches a pre-determined point. Since most of these toy records are designed for high-speed reproduction, reduced-speed recording techniques apply here.

“Name three reasons why  
BOZAK Sound Systems  
are preferred  
wherever quality counts”



### “1. BOZAK Mixers”

These all-solid-state mixers are full-professional, full-Bozak quality. They have the compactness, versatility and flexibility to fit any application. Yet, their cost is moderate. Plug-in modules permit use of any position for any type input—high level, low level or phono. Available are 6-input and 10-input mixers and integrated 5-input mixer, 50-watt amplifier.

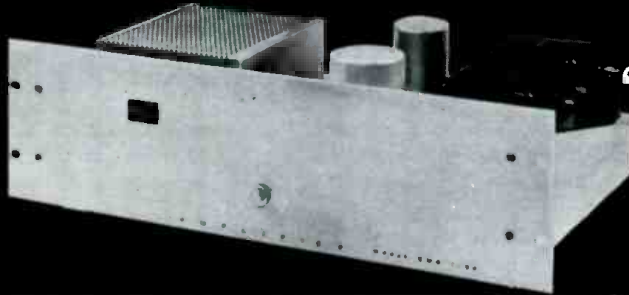

### “2. BOZAK Amplifiers”

Bozak's CMA-1-50 50-watt power amplifier has proven its reliability in every type of service, including reinforcement for many of the nation's leading symphonies. Even at its full rated power, its frequency response is within 1 db from 20 Hz to 20 kHz.

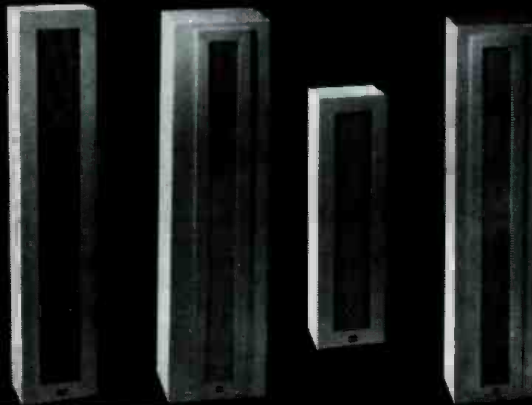

### “3. BOZAK Columnar Speakers”

There's a Bozak sound column specifically engineered for every application—large area or small area; indoors or outdoors; voice or concert—a total of seven different models. Each model is backed by Bozak's long experience in the design, manufacture and application of loudspeakers. And because Bozak manufactures every component—even including its own cones—it can maintain the highest quality control standards in the industry.

Get the full story with complete and accurate specifications in the Bozak catalog “Column Loudspeakers and Associated Equipment”.



Commercial Sound Department  
**The R. T. Bozak Manufacturing Company**  
Box 1166 Danvers, Connecticut 06820

Circle 16 on Reader Service Card

# Theory and Practice

NORMAN H. CROWHURST

● Picking up where I left off last month, I'm still thinking of the simple line amplifier, designed to use input and output impedances of 500 ohms. Now, let us examine what happens when they are cascaded so that they don't happen to match their nominal ratings.

In all modern circuits, after designing the circuit to use the amplifying elements (tubes or transistors) in as linear a mode as possible, over-all feedback is applied in lashings to bring down distortion to the lowest possible level. And we often trust the feedback when something we inadvertently did excuses it from doing its proper job!

If the output impedance is lower than the nominal load it is designed to load, it's safe bet that voltage feedback is used, because that is what will make source impedance lower. Let's take the same case where the internal output impedance is 100 ohms to feed a 500-ohm external load (FIGURE 1).

The combined parallel impedance, with the load connected, is 83.3 ohms. Let's assume it has 14 dB feedback. Without feedback, the combined impedance would be 5 times 83.3 ohms, or 417 ohms. But part of this combined impedance (as a parallel element of it) is the 500-ohm load. So the source-impedance part, without feedback, must be 2,500 ohms. (2,500 ohms parallel with 500 is 417 ohms).

With load connected, the feedback factor  $(1 + AB)$  must be 5, or  $AB=4$ , to get 14 dB feedback. With the 500-ohm load, 1/6th of the open-circuit output voltage is fed back. With a 100-ohm load, this will drop to 1/26th. So

this change will cut AB from 4 to 0.765 and the 14 dB feedback will become only 5 dB — quite a change!

Not only is there less feedback, but to produce the same output level, the input must be bigger (about 5 times). This will be allowed by the drastically reduced offset from the feedback signal. So distortion is likely to increase on two counts: higher internal operative level, and less feedback. So the specified performance becomes fictional!

Taking the other case, if the effective output internal source impedance is 2,500 ohms for a 500-ohm load (FIGURE 2) any feedback used must be of the current type, and the reverse situation applies. Working into a higher load, say 2,500 ohms, such as an amplifier input designed to work from 500 ohms, reduces current feedback by a similar factor also increasing distortion.

Using opposite deviations, for example a 2,500-ohm input impedance as a load for a 100-ohm output impedance (each designed to work with 500 ohms) the feedback will increase considerably. Take the same example we just calculated in FIGURE 1. If the voltage from 500 ohms that was fed from 2,500 ohms (actual source) yielded an AB factor of 4 (being 1/6th of the open-circuit voltage), changing the 500 ohms to 2,500 ohms will feedback half the open-circuit output voltage and raise the AB factor to 12, yielding about 22.25 dB feedback, instead of the design value of 14 dB.

That extra 8 dB feedback will reduce distortion more than intended, so there's no trouble about that, is there? Hold on a moment! Did you ever hear of instability?

Admittedly, no professional amplifier is likely to go unstable, using any loading from short-circuit to open-circuit, so it won't actually oscillate. But...

The amount of feedback, and the effect it produces, is probably optimized with correct or nominal loading. After all, that's when any self-respecting amplifier should do its best. And if, as many professional amplifiers do, it includes an input or output transformer, or both, there may be more reasons for difference when the actual load differs from the nominal. Whatever the change in loading and amount of feed-

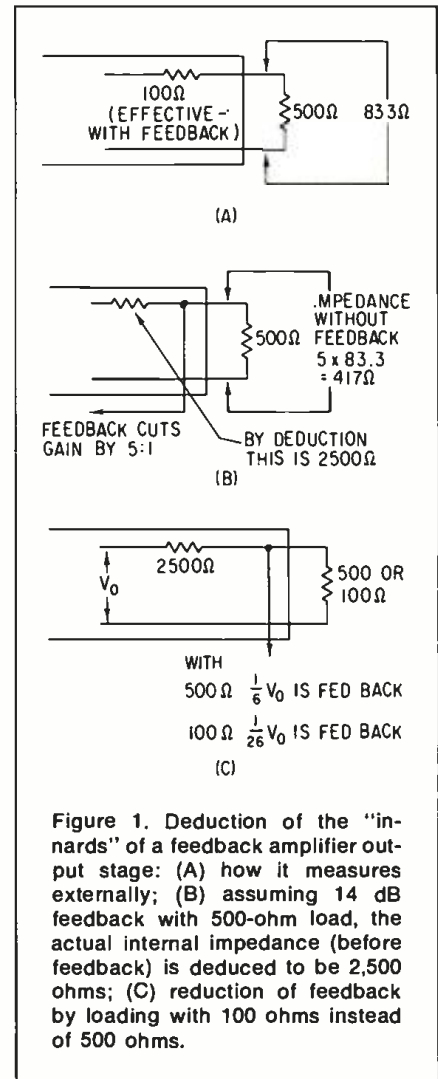

Figure 1. Deduction of the "innards" of a feedback amplifier output stage: (A) how it measures externally; (B) assuming 14 dB feedback with 500-ohm load, the actual internal impedance (before feedback) is deduced to be 2,500 ohms; (C) reduction of feedback by loading with 100 ohms instead of 500 ohms.

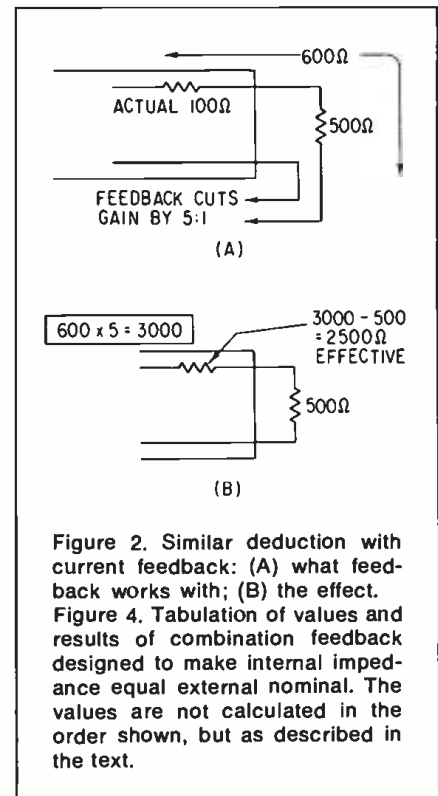

Figure 2. Similar deduction with current feedback: (A) what feedback works with; (B) the effect. Figure 4. Tabulation of values and results of combination feedback designed to make internal impedance equal external nominal. The values are not calculated in the order shown, but as described in the text.

## Are you taking advantage of db's Classified Advertising?

It's the low cost way to reach prospective buyers or sellers of equipment, potential employees or employers. And if you do not wish to be contacted directly, you can use a box number at no extra charge. Get results with a classified ad in db.

back, it will change response. The question is where and how much.

If the circuit is a simple one, optimized for maximal flatness response, 8 dB of extra feedback will produce about 4 dB peak at one or both ends of the frequency range. The effect could be worse than this, since I have assumed optimal design.

The low-frequency effect could run the amplifier into break-up, excited by any low-frequency transient. The high-frequency effect could produce an unnatural edginess, characteristic of an ultra-sonic peak.

In the example, we assumed 14 dB feedback. This was based on the effective internal impedance being either 1/5 or 5 times nominal value. If 20 dB feedback were used, the internal impedance would be about ten times, or 1/10 of nominal value, according to whether current or voltage feedback, respectively, was used. And using that much more feedback would aggravate possible changes in performance.

Transformers in the circuit, assuming they are excluded from the feedback loop (if they're included, the effects could be compounded) can change the response from maximal flatness to as much as an 8 or 9 dB peak, or to a similar loss at extreme frequencies, unless the circuit is skillfully designed to avoid such an effect.

If the input transformer is step-up or the output is step-down (the commonest arrangements used) then terminating externally with an actual impedance that is *lower* than nominal will be likely to cause *peaking*. Terminating externally with an actual impedance that is *higher* than nominal will cause a *loss* in response.

If the input transformer is step-down or the output is step-up (both of which are less common) then terminating externally with an actual impedance that is lower than nominal will be likely to cause a *loss* in response, while one higher than nominal will cause *peaking*.

Perhaps you now have the impression that no line amplifier can be as good as it ought to be. This isn't quite true. Its nominal performance can al-

ways be obtained by using its nominal loading, strictly. This may involve extra audio losses in the matching pads required to eliminate the inadvertent mismatch. But it is also possible to design an amplifier that is not susceptible to this problem.

Transformer-coupled circuits can be designed so that a change of external load value, within a likely range, does not materially change response. This only requires extra care in the design, which we won't go into here.

To ensure that an amplifier has an internal output impedance that matches the external impedance with which it is designed to work, dual feedback must be used to obtain adequate linearization; this should be both voltage and current, as related to the output stage.

Let's assume an output transistor or tube has an impedance 5 times the nominal load it is to work with (FIGURE 3). The parallel impedance will be 5/6th nominal. For source-to-equal load, the parallel value must be reduced to 1/2. This is a gain reduction of 5/3, or 4.4 dB. This much voltage feedback is not enough to do much good in reducing distortion. Now suppose the designer decides to use about 26 dB feedback, which means (1 + AB) must be 20.

First assume the current feedback with nominal load connected uses an AB factor of 9 (FIGURE 4). This is with a total output circuit impedance of 3,000 ohms, 2,500-ohms internal and 500-ohms external. A short circuit will reduce the total load to 2,500 ohms, increasing current feedback to an AB factor of 6/5 x 9=10.75. On short-circuit there can be no voltage feedback. So (1 + AB) at short circuit is 11.75.

With a nominal load (500 ohms) the output current should be half the short-circuit current, if source impedance equals load impedance. If the output-source voltage is unchanged, the rise in impedance from 2,500 ohms (short circuit) to 3,000 ohms (nominal load) will reduce output current by 5/6. So the voltage feedback, with nominal load, must reduce the source voltage by a factor of 3/5 (3/5 x 5/6=1/2).

As the short-circuit factor is 11.75, the nominal load feedback factor (including voltage and current components) must be 5/3 x 11.75=19.56 (close to the desired 20, representing 26 dB).

Subtracting the 1 (of 1 + AB) and the AB=9 for current feedback (the figure we started with), the voltage feedback needs an AB of 9.56. Now as a check, let's see what happens if we change the external load to 2,500 ohms.

This will raise the voltage feedback AB product from 1/6 to 1/2 the open-circuit output voltage, a 3/1 ratio and cut the current feedback AB in the ratio 3/5. Thus voltage AB is 3 x 9.56 =28.6 and current AB is 3/5 x 9=5.4, making a total AB of 34. So (1 + AB) is now 35, making gain drop by 19.56/35.

Output voltage, before the effect of feedback is considered, rises 3 times, due to the change of loading, which delivers 1/2 instead of 1/6 the open-circuit voltage. So with feedback considered, output voltage rises by 3 divided by 35/19.56, which figures out to 1.675.

According to our calculation (last month) terminating a 500-ohm source with 2,500 instead of 500 ohms should cause the voltage to rise from 1 to 1.667, which is as close as we can expect such calculations to come.

That's about enough for one issue. We could pursue this much further. What would you like me to do? Do you want more details, so you could design your own line amplifiers? Let's know, and when I have enough answers to know which way you would like me to go, I'll write more on this subject. Meanwhile, in the next issue, I'll be guided by letters I've received already.

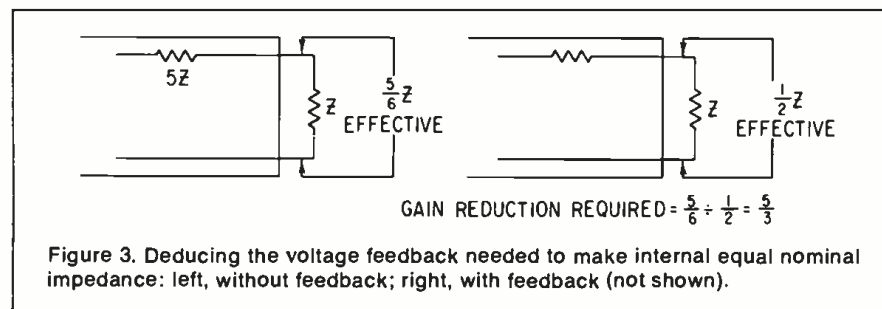

Figure 3. Deducing the voltage feedback needed to make internal equal nominal impedance: left, without feedback; right, with feedback (not shown).

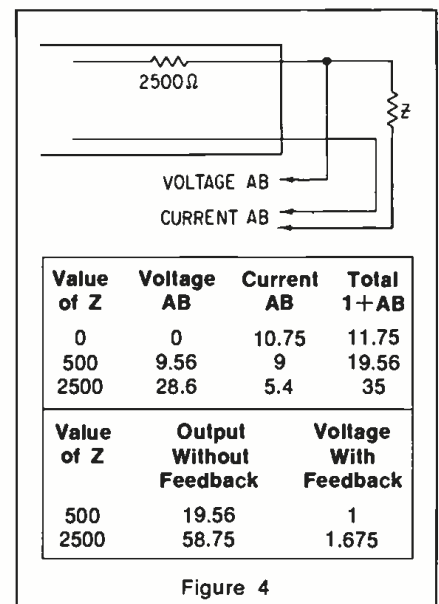

Figure 4

# New from Neumann:



**FET-80 Series Microphones, with Compatible Central Powering**  
 Good news for people who *wanted* the finest, but couldn't afford it. Now you can obtain the new Neumann microphones—solid state and still unchallenged for acoustical quality—at prices up to 30% lower than before.

Using advanced transistor electronics, FET-80 Series Microphones enable you to enjoy famous Neumann performance, plus the flexibility of central compatible power; long-life battery operation; two-year guarantee, and more. All at tremendous savings.

FET-80 Series Microphones are currently available in four models, priced from \$276 to \$418.

# Free from Gotham:



Information that tells all about them. Gotham is the sole U.S. distributor of Neumann microphones, so we know more about them than anyone else. Mail the coupon below, and we'll send you an illustrated brochure describing Neumann's new FET-80 Series Microphones. We'll also send you an informative technical article that you'll refer to often. The supply is limited. (It really is!) So write today.

**Gotham Audio Corporation**  
 2 W. 46th Street, N.Y., N.Y. 10036

Please send me your free brochure and technical article describing Neumann's FET-80 Series Microphones.

Name \_\_\_\_\_

Company \_\_\_\_\_

Address \_\_\_\_\_

City \_\_\_\_\_ State \_\_\_\_\_ Zip \_\_\_\_\_

Circle 17 on Reader Service Card

# Sound with Images

MARTIN DICKSTEIN

● One common denominator to almost all audio-visual systems is the projection screen, true whether the method of image presentation is front or rear projection. This look at some of the different types of screens illustrates one phase of an audio-visual installation — perhaps the weakest link in the entire projection chain.

The purpose of the screen, of course, is to present to the audience a large enough and bright enough picture for all to see clearly under the ambient light conditions in the viewing room. With front projection, the viewer sees only that light reflected from the screen. In rear projection, the audience sees only the light that the screen permits to pass through it. In either case, the efficiency of the material chosen determines the brightness, evenness, contrast, and color intensity of the image.

## Front Projection

Several different types of screens are available for use in a front-projection system and each has its particular characteristics and applications.

The matte screen is able to diffuse light evenly in all directions. Thus, images on matte screens appear to be equally bright from almost any viewing angle. Matte screens are not, however, perfectly efficient and cause approximately 15 per cent of the incident light level to be lost. An illumination, therefore, of 100 foot-candles on the screen will provide a screen surface brightness of about 85 foot-lamberts. Although the image will appear to be of equal brightness at almost any viewing angle, it should be realized that seeing the image from too far off to one side will result in distortion to the viewer. The general practice is to keep the seating arrangement so that the end seats are no more than about 35 degrees off the center axis of projection. Another general rule to follow is to place the first row of seats at about twice the width of the screen and the last row no farther away than about six times the width. This may vary, depending on the material to be projected and the method by which the film or slide was prepared, or the size of the lettering or other information depicted on the screen.

## Lenticular Screens

The word *lenticulation* is derived from the same root as lens. This fairly accurately describes the surface of the projection material. The surface is made with a regular horizontal and vertical pattern of minute reflective areas shaped as rectangles or diamonds. This pattern is too small to see at the normal viewing distances. By controlling the shape of the tiny reflective surfaces, viewing angles and brightness can be regulated. Those with wider angles usually have less gain while those designed for higher brilliance of image have narrower angles. Lenticular screens are available with the capability of providing images several times brighter than a matte screen.

## Beaded Screens

This type of screen can be considered to be an early attempt to lenticulate the screen surface by imbedding or attaching tiny clear glass beads to increase reflection. The advantage gained is that the image is very bright but this is within a narrow viewing angle. As the angle increases, the viewer gets less

*Are  
 you  
 taking  
 advantage  
 of db's  
 Classified  
 Advertising?*

It's the low cost way to reach prospective buyers or sellers of equipment, potential employees or employers. And if you do not wish to be contacted directly, you can use a box number at no extra charge. Get results with a classified ad in **db**.

reflection until he moves to about 25 degrees from the projection beam axis, when the brightness becomes comparable to that seen from a matte screen. If the angle is increased further, the image brightness will drop below that of a matte screen. A second disadvantage of the beaded screen, inherent in its high reflectivity, is that ambient light is also reflected so that stray light falling on the screen can prove to be a serious problem. This type of screen is very common, however, because of its high brightness, economy and because it can be seamed, if necessary, to increase its size without the seam showing during projection (an inherent characteristic since the beads are placed haphazardly to saturate the screen surface for complete coverage).

### Smooth Metal Surfaced Screens

This type of screen is, perhaps, more efficient than the beaded type for reflective characteristics. It can be made with an aluminum or silver surface. However, this surface does not lend itself to wide-angle viewing, and audiences must be within a 30-degree cone. It does have the advantage of being able to reject stray light and for this reason is used in rooms where other lights have to remain on during the presentation. Smooth metal screens are rare today.

### Lenticular Metal Surfaced Screens

The application of the lenticulation process to the metal surface created a screen with the capability of being used for larger audiences, since the side viewing areas were increased. The lenticulated silver surface can be used in rooms where ambient lighting is a necessity. It has high brightness, high contrast, and good color fidelity. The

fact that it is also available in roll-up size and will not be easily damaged makes it possible to use this screen for portable-type projection systems; thus it has the advantage for providing for wide-angle seating in small projection rooms. The picture on this type of screen will be brighter than on a matte white.

### Rear Projection Screens

Rear projection screens are made chiefly of three different materials: *glass*, *acrylic plastic* and *vinyl-latex plastic*.

*Glass*: This type of rear screen material offers several advantages. It is rigid and can, therefore, be mounted in a manner to take advantage of its permanent flatness. It also offers highest quality pictures and maximum sound isolation. However, being glass, it is breakable and heavy in large sizes. As the screen is made with one surface coated and polished, this surface, when mounted facing the audience, can be used as a blackboard with a wax marker. It can be cleaned easily with a damp cloth.

*Acrylic plastic*: This material has the advantage over glass of being lighter and less breakable. It is less rigid, however, and should be solidly mounted to keep it from bending or vibrating. As with glass, the coated surface can be used as a blackboard. However, sound isolation is not as good with this material as with glass, this must be taken into account if the rear projection is to be a noisy one during presentations.

*Vinyl-latex*: This material, being the most flexible of the three, must be mounted in tension to keep it from losing its flat projection surface. It is, however, suitable for the use of grommet holes at the sides to help in mounting and is thus specially useful as a port-

able screen as it is light and can be rolled easily. It lends itself best to rear projection where the image is to be a background for display set or stage presentation.

In general, rear-screen projection is used for smaller rooms or audiences than front projection and is better for rooms in which ambient light is a requirement during projection. As rear projection inherently requires that the projectors be located outside the seating area (behind the screen) the proper projection distance must be provided for the size of the image desired. Sometimes, this is not possible and a front-surface (or first surface) mirror must be installed in order to provide the proper distance without requiring a long behind-the-screen distance.

Rear projection screens are available made of dark or light material. The material should always appear black when seen by the audience before or after the presentation as this will result in lower reflection of ambient or stray light. However, if the room is to be used for projection purposes only and will be very dark during presentations, the material can be light. Generally, rear screen projection offers bright pictures, good color quality and a wide viewing angle.

During subsequent discussions, charts of audience capacity, brightness requirements, screen sizes, and other criteria to be considered for a successful projection presentation will be offered for reference. Special devices used in audio-visual displays, different techniques, lenses, room layout requirements will also be discussed. Similar subjects will also be considered for closed circuit tv. However, we still want your letters, questions, comments and reactions to be included in this column. Send them in.

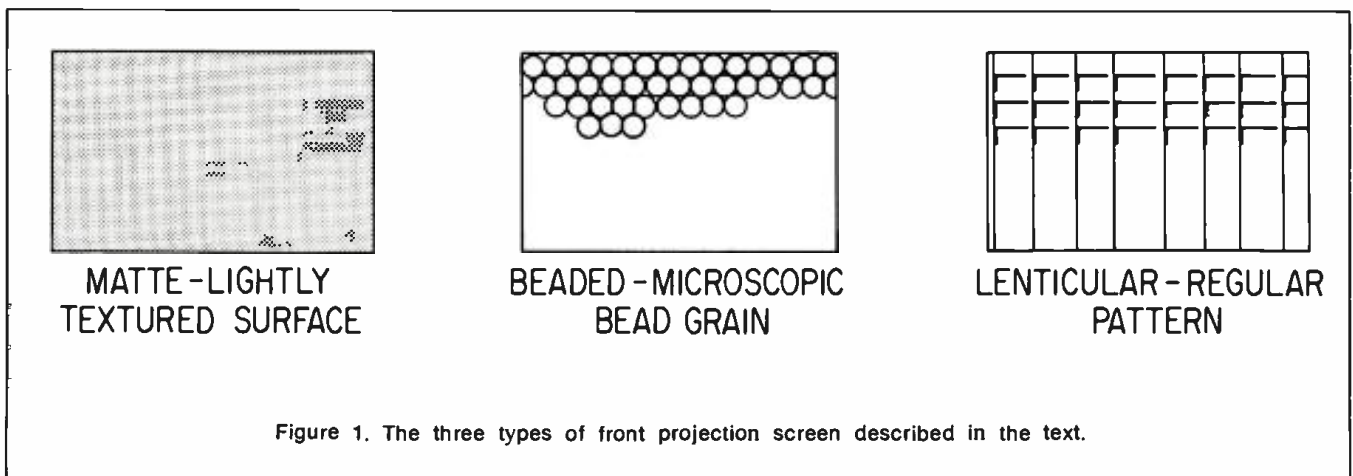

Figure 1. The three types of front projection screen described in the text.

# The only complete line of Integrated Circuit Audio Equalizer-Amplifier Modules available...

The Electrodyne Modular series employs the latest integrated circuit differential amplifier design techniques and has been developed for maximum quality, function integration and reliability. Any of Electrodyne's 6 Input Modules offer the following, used with any of 8 Switching Modules, our LA-602 Program Amplifier and our ACN-1P or ACN-2P Combining Network they provide all the electronics and channel switching necessary for a basic Audio-Control Console.

All Electrodyne Input Modules share these features. Each are completely interchangeable and wire to the same plug. All provide isolated echo send output with independent level control. All draw less than 40MA at 24VDC and are available without input attenuators.

The 309L, 509L and 709L incorporate a low noise microphone pre-amplifier, an input switch for selection of line or microphone input, -10db and -20db to accommodate various microphone output levels.

Low frequency equalization point of the 409L and 509L is 100Hz and the high frequency point is 10kHz. Low frequency equal-

ization points of the 609L and 709L are selectable at 40 or 100Hz and the high frequency points are selectable at 1.5, 3, 5, or 10kHz.

The 609L and 709L have a coaxially mounted switch which selects echo send output from before the attenuator or after the program amplifier.

These all silicon, solid state integrated circuit amplifiers have been proven in high-reliability military and computer systems, and records of tens of millions of hours without failure are not uncommon. These amplifiers operate well below their maximum output capacity. Substantial amounts of feedback around each amplifier provide extremely low distortion, while insuring the highest circuit stability. Units are virtually insensitive to wide variations in power supplies, ambient temperatures, capacitive and inductive loads. All plug contacts on the printed circuit board are nickle-rhodium for added dependability while all switching contacts used have a proven reliability of over one million operations.

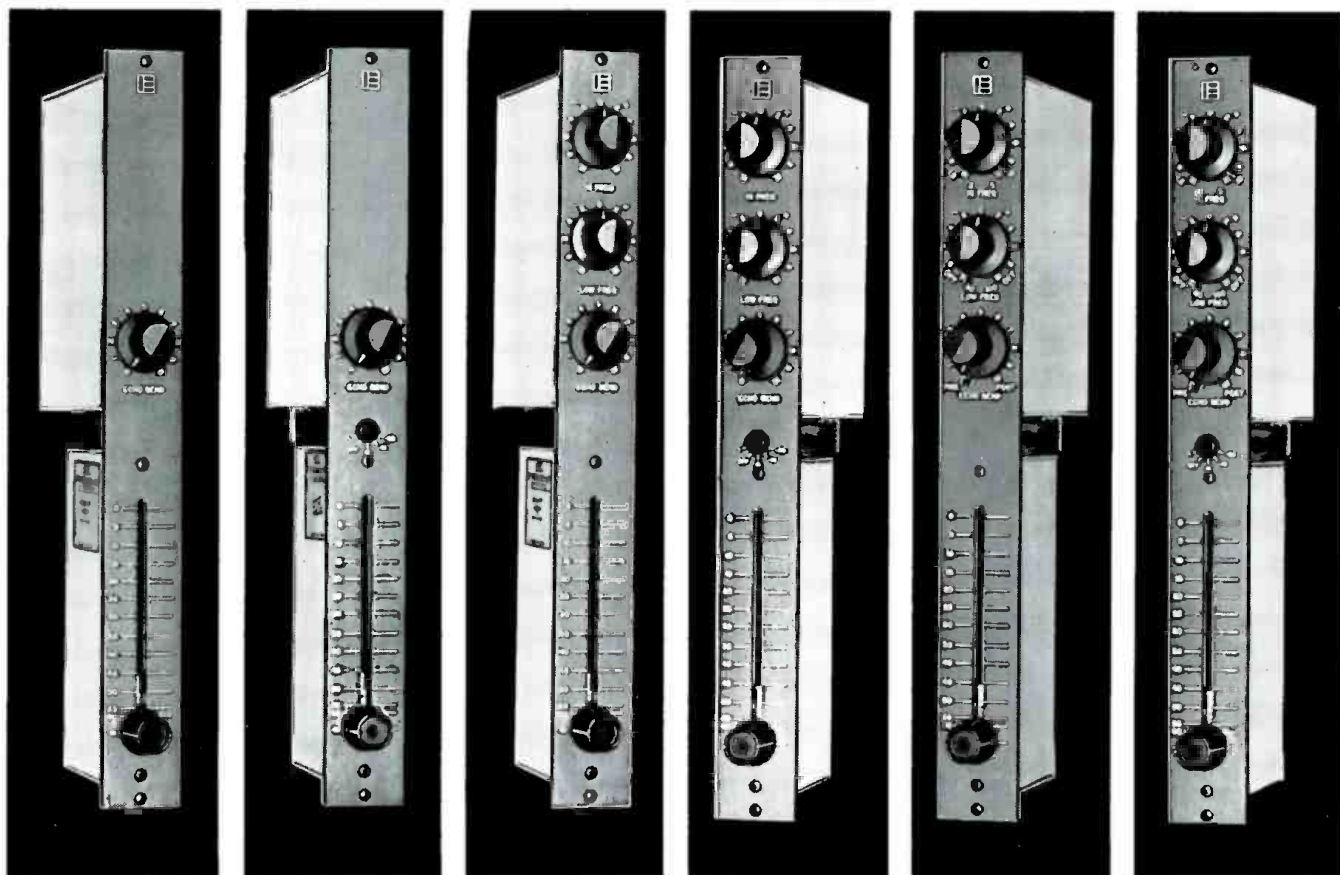

**209L**  
Line Level Input

**309L**  
Line level or  
microphone input.

**409L**  
Line level or  
2 frequency  
equalization.

**509L**  
Line level or microphone  
input, 2 frequency  
equalization.

**609L**  
Line level input,  
6 frequency  
equalization.

**709L**  
Line level or microphone  
input, 6 frequency  
equalization.

The finest too, because they're Electrodyne, "The World Leader"



**ELECTRODYNE  
CORPORATION**

7315 Greenbush Avenue ■ North Hollywood ■ Calif. 91605  
Phone: (213) 875-1900 ■ Cable Address: "ELECTRODYNE"

Circle 18 on Reader Service Card



# Editorial

**T**HOSE OF YOU being introduced to **db** at the west coast AES Convention ought to know that our premiere issue was presented at the east coast AES Convention just six months ago. This time period hardly makes for an anniversary celebration — half a year is nothing to crow about even with the known high mortality rate among new publications. But we did want to take note of the unofficial bond that exists between the AES and this magazine. We travel a kind of parallel course, complementing each other's functions.

The AES is a growing organization that we would like to see grow faster. To those of you not yet involved, we strongly urge AES membership. A unified profession wields considerable power, and this power is needed — in standards of operation and practice. Let's develop *audio power*.

---

A recent letter asked why our logo, **db** uses a small letter **b** when the standard in use capitalizes the **B** to honor the name of Alexander Graham Bell.

Our logo was designed to symbolize a new engineering *magazine*. It echoes the familiar **dB**, but it never intended to copy it. Quite the contrary, **dB** must stand as its own unique symbol . . . for *decibel*. That is why we use the standard **dB** designation in our editorial copy.

But this raises a number of other questions about standards. Why is it **dB** — but decibel (not deciBel)? Why is it 117 V and 117 volts (not Volts)? Why do we continue to use an upper case Greek omega ( $\Omega$ ) for ohms—not the lower case ( $\omega$ ) omega?

And then there is the controversial Hz. Many audio pros feel strongly that the change is correct; others are just as adamant that this usage is an error. Is Hz or hertz (there's that inconsistency on capitalization again) really more useful to an engineer than cps or cs./sec.?

What does the audio professional want? Is it Hz or cycles per second? Is it mV or mv,  $\mu$ A or  $\mu$ a?

Drop us a card and express *your* preference as an audio pro. We'll publish the results.

---

In the latter part of March, New York City was host to the annual convention and exhibition of the IEEE. This mammoth affair has, in the past, had some interest for audio pros, but each year the show has become more and more directed toward the componentry used to create military systems. We spent a day at the New York Coliseum wandering the four floors of exhibits in search of audio interest. It wasn't there.

The few hardy manufacturers who did show audio equipment were ignored by the bulk of the visitors.

The IEEE show has passed our audio field by.

L. Z.

# Making a Printed Circuit Board

Richard L. Lerner

*The audio professional is often called upon to construct small circuits. Printed or etched circuit materials can facilitate the job considerably. This article details several of the methods used for small-scale boards.*

**M**ANY construction articles and projects show printed circuitry as the wiring method of the device. With a printed circuit, the constructor of occasional circuits can be certain that his copy matches the original in such vital considerations as lead spacing, component orientation, uniform capacitance between leads, and similar interaction effects.

In industry, the single-sided printed circuit is utilized principally because it offers manufacturers a savings in assembly and wiring costs, in addition to reasons of accuracy. Double-sided boards are used for volume reduction needs.

## *Sequence of Construction*

- 1. Parts Layout and Circuit Configuration*
- 2. Conductor Path Layout*
- 3. Conductor Path and Pad Taping on Clean Film*
- 4. Photographic Reduction*
- 5. Photographic Projection on Photoresist*
- 6. Etching and Cleaning*
- 7. Plating, Drilling, Cutting, and Eyeletting as required*
- 8. Component Insertion*
- 9. Soldering*
- 10. Test*

This sequence represents one of the roads toward the development of a small-scale printed-circuit. Alternative for creating a copper conductive path on a board are discussed in the text.

*Mr. Lerner is a section staff engineer in the environmental test section of Grumman Aircraft Corp. Bethpage, N.Y. He is also an assistant editor of db.*

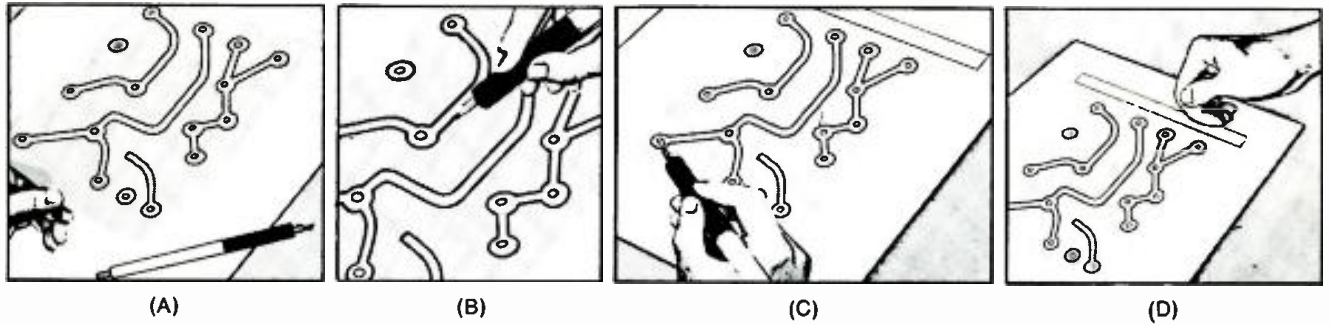

Figure 1. The steps necessary to use Ulano Rubyolith® masking films. In (A) a sheet of this transparent deep red material is placed above the original drawing. A sharp knife traces the circuit paths (B) cutting through the red coating. Then lifting the edge with the knife, (C) the red is stripped off (D) leaving a clear plastic coating underneath. This can then be used as either a positive or negative for the etching procedure.

The usual industrial processes will be described, and then the applicable parts will be used for small-scale construction, considering particularly that the average project is not a production effort involving large numbers of boards. The do-it-yourself process consists of laying out the parts and circuit in the desired configuration and connections, making a large-scale pattern, reducing it photographically, imprinting it on the copper clad insulating material in such a way that the undesired copper may be etched away and the conductive paths left. Then fabricate and assemble to produce the desired end product, an electronic module consisting of component parts connected together by the best commercial conductor — high-grade copper.

The industrial designer, starting with a schematic, makes a large scale layout, usually 4:1, of all the components on a grid layout, showing all connecting paths and usually a pattern which will mate with a standard printed circuit connector. A piece of transparent Mylar (DuPont) or similar stable material is fastened over the layout. Tapes and pre-punched patterns of 4X shapes such as pads, curves, transistor mountings and just about anything else commonly used, are pasted down in the proper position. These tapes are flat black in color. Corner markings and sometimes cutting lines and identifying markings or lettering are appropriately placed. Great attention is paid to removing any light colored areas or gaps on the patterns obtained, as these might become pinholes in the completed circuitry, or even worse, failure to complete a circuit. The tapes may be joined by overlaying strips, since the next step is not particularly sensitive to depth.

Following a meticulous check, the pattern is taken to a photographic shop, where, depending on the etching process intended, a 1:1 scale clear negative or positive is produced. This is also checked for pinholes. Many economic questions influence the method that will be used from here to completion, but the ultimate result is to obtain a pattern on the copper-clad board that is such that an etching chemical cannot etch away the desired copper areas. Etch-resistant material, commonly called *resist* can be directly silk-screened on the board, using a silk screen made from the photo obtained earlier. Another type *resist* is a light-sensitive emulsion which does not become etch resistant until after light exposure and (sometimes) development processes. Whatever the resist application method, the boards are inspected for undesired resist-free areas, touched up if necessary, and placed in a bath which removes the undesired copper. Fre-

quently the circuit, after cleaning, is plated with metals such as gold (very thin plating) or solder to improve later solderability and to minimize corrosion. Areas like connectors, where wear is expected, are plated with hard metals such as rhodium. Holes are drilled for the component leads. Frequently small eyelets are used in the holes to improve reliability. Many ingenious machines have been developed for automatic insertion and soldering. The use of these or similar processes is not reserved to industrial giants. Many printed-circuit vendors are equipped to handle and welcome experimental or low-volume orders. Some will work from a hand-drawn schematic and layout.

The process just described is quite common, with variations limited only by the ingenuity and financial resources of the industrial concern. As volume gets higher or packaging density greater, the simple printed-circuit board becomes multi-layer, double-sided, interconnected, modular, miniaturized, flexible (even printed-circuit cables!) and in some cases even has components such as high-frequency inductors and capacitors formed by the copper pattern. There are also techniques, many of them patented, for using the copper lines as microwave waveguides, and as high-efficiency antennas.

How can all this be applied by the occasional fabricator? Let us list the steps in the industrial processes and discuss their applicability or necessity to the low-volume, low-cost, but not necessarily low-precision small project. Remember that most industrial processes are carried out by individuals. In particular, the taping of a printed circuit layout is usually done by one man working on a large, flat surface, placing tapes, pads and sometimes using black ink to form light opaque patterns. The scale used depends on the processes intended; most photo reduction is done at 4:1. There is no reason why you cannot work at 1:1, but closer spacing and neater boards will result if photo reduction is planned and used properly, since minor errors become  $\frac{1}{4}$  the size in 4:1 reduction.

*Layout:* This is where extra attention yields not only a better looking board, but a board into which components can be assembled and if necessary replaced with ease. The smallest line width that you should consider is  $\frac{1}{16}$  inch. Line separations of at least that figure are recommended, particularly if a photo reduction process is not contemplated. Effort should be made to have components faced so that values or markings may be read, so that adjustments can be made easily, and to provide uniform orientation. The

last is particularly helpful when the circuit contains polarized components such as diodes.

**Taping:** Taping supplies are available at most drafting supply houses. If not, tapes and prepunched pads may be purchased from several companies including **By-Buk** and **Chart Pak**. There is no reason, for one or a few boards, why you cannot eliminate production steps. The tape may be applied directly to the board, as it is sufficiently etch resistant to be used. Others may prefer to use a very convenient process marketed by **Vector** (and possibly others). Printed pads, lines and other useful patterns are available in sheets. Rubbing the back of the sheet transfers the pattern, which is composed of resist, onto the board. With either tapes or transfer-resist, be careful to inspect all joints to be sure that tapes don't overlap, leaving a gap that permits etchant to creep underneath, and that resist gaps are eliminated. Here, a small amount of liquid etch-resistant material is helpful. In a pinch, enamel paint or nail polish can be used.

There is another process, frequently used by industry, which can be helpful. Assume that the pattern of lines, pads, etc. is available, in correct size. There is a material called **Rubylith**® (Ulano Corp.) available. It is a laminate of red and clear plastics. The red plastic is cut away with a small knife from those areas where it is desired to leave copper. This material, together with photo-resist can be used to make excellent boards. As an added advantage the same piece of Rubylith can be used to make more than one board. This process is illustrated in **FIGURE 1** showing the cutting, peeling, and finished product. The required material is available at many art supply stores in most metropolitan areas, according to the manufacturer.

**Photo-reduction:** While I haven't tried to do it myself, I understand that many commercial and studio photographers welcome photo-reduction work. Keep the board size small or you will pay quite a fee. The etch-resist process will determine whether a negative or positive image is desired. The advantage of multiple boards from one pattern obviously exists here also. Other advantages are precision, location accuracy, and uniformity. This process usually takes time, so allow for it in planning.

**Etch Resistant Application:** The simplest and least complicated method of resist application is to paint the desired pattern onto the copper with a fine brush. This technique

is frequently used for low-precision one-of-a-kind boards.

Precision may be improved by using tapes or rub-on resist as an etchant mask. If a photoreduction or Rubylith® mask has been made, then the raw board may be evenly coated with photoresist. This material becomes etch resistant only after exposure to intense light. Follow the manufacturer's instructions for application and development, but remember that in this, as in any chemical process, cleanliness, uniform mixing and application, and a respect for caustic materials is extremely important.

Vector, among other companies, offers a variety of etch-resistant patterns which may be transferred to clean copper by rubbing over the backing paper on which the patterns are supplied while carefully holding the board and pattern in alignment. Touch-up resist comes with the patterns. The company also markets, through most of the common radio parts houses, a complete kit containing board material, resist patterns and touch-up resist, and etchants.

**Plating:** This step is usually included on commercial boards for its protective qualities, particularly against contact wear and corrosion. The processes involved are sufficiently complex to be out of consideration for small-scale projects. With the exception of some gold-flash dips, most plating requires high current supplies, electrodes, multiple baths and considerable experience. The use of plated circuits is best left to the industrial practitioner.

**Drilling, cutting and eyeletting:** For the usual project, drilling consists of selecting a drill which makes a hole large enough to pass the thickest component lead without obliterating the pad, and drilling the holes.

During any fabricating process, care should be taken to prevent injury. You should be aware that glass fiber reinforced boards, when cut, have glass chips in the sawdust, which should not be inhaled, or allowed to get into eyes. In addition, some people are allergic to some plastic dusts. Within the above cautions cutting printed-circuit boards may be done with tools such as sabre saws, jig saws or files.

While it does require more space, in terms of larger pads, the use of eyelets is common. An eyelet holds down the copper pad during lead insertion, soldering and repair. Convenient hand tools and supplies of eyelets are available from many of the electronic mail-order supply houses.

**Component insertion:** This might seem a trivial process,

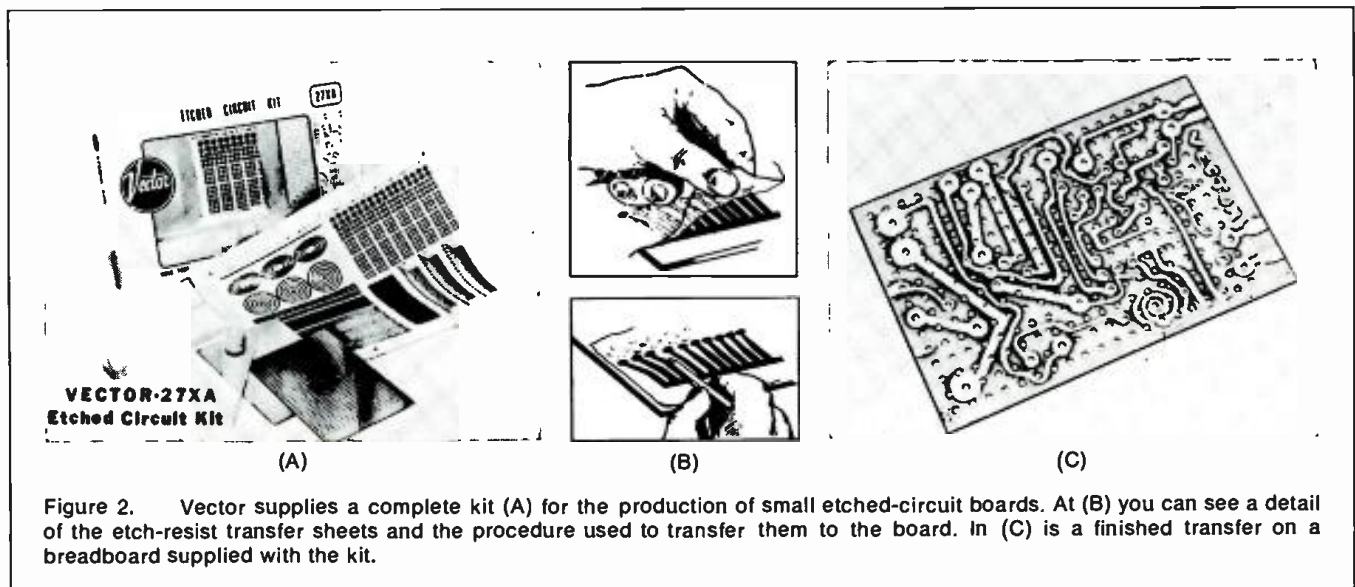

Figure 2. Vector supplies a complete kit (A) for the production of small etched-circuit boards. At (B) you can see a detail of the etch-resist transfer sheets and the procedure used to transfer them to the board. In (C) is a finished transfer on a breadboard supplied with the kit.

but care taken here, and in designing a layout to permit proper insertion techniques, can yield a circuit of higher reliability and of easier maintainability, (to say nothing of just looking neater).

Most electronic components can be broken or severely strained by bending their leads too closely to the body. The usual allowance for high reliability boards is 1/8 in. between the component and the start of any lead bend, with a minimum bend radius of several lead diameters. For your occasional construction purposes, adding 1/4 in. to the component length when laying out pad centers is sufficient. Use care not to bend the leads so tightly that they form a sharp corner. Form them parallel to each other and perpendicular to the body. Insert them into the correct holes using care to orient critical components such as diodes, polarized capacitors, and transistors correctly. It is neat and also convenient to orient resistors so that the color codes line up in one direction.

As each pair of leads is inserted, push the component all the way down onto the board, and bend the protruding leads about 45 deg. in the direction of the line connected to the pad. Then clip it off leaving about 1/8 in. There are three reasons for this: the component is held during subsequent operations, the joint when soldered is strong, and servicing will be easier than if the lead had been fully bent.

**Soldering:** Printed-circuit soldering does not differ from the kind of soldering usually encountered in most electronic kits or assemblies, except that care must be exercised not to overheat the joint. Overheated printed-circuit lines will peel from the board easily. They may even fracture just from the differential rates of expansion between copper and plastic. Most commonly however, the relative neophyte will be so afraid of overheating that he will fail to heat the joint properly, winding up with a cold solder joint. The technique I use is to rest a properly trimmed soldering iron tip of about 25 watts rating, on the component lead until the lead is hot enough to melt solder applied to it. Quickly move the iron so that the tip rests against the pad as well as the lead, while applying solder to the lead and the pad. As soon as the solder has flowed smoothly around the desired area, remove the heat. The result should be a smooth, shiny, slightly conical joint. Inspect it for evidence of a cold joint (wrinkled, dull appearance) or of overheating and peeling. Severe

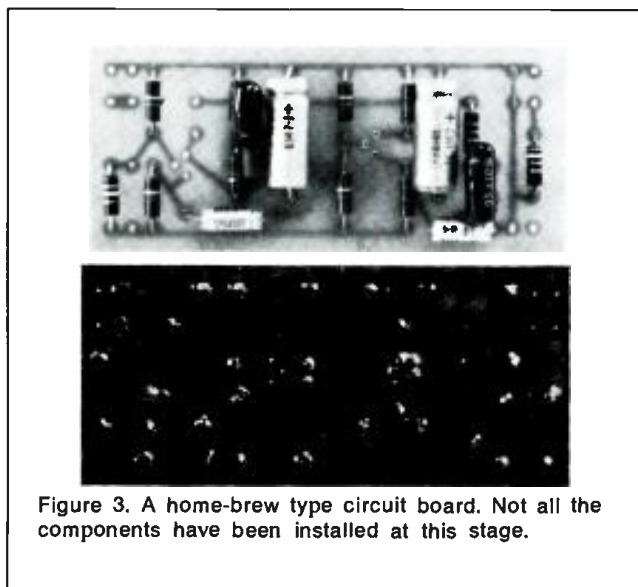

Figure 3. A home-brew type circuit board. Not all the components have been installed at this stage.

overheating might require tacking a piece of wire in place of a conductor. Cold solder joints are easier—simply resolder carefully. It is not necessary to hand solder the entire conductor surface.

**Testing:** Of course, the final step is testing. Just how much is needed will be determined by the nature and extent of the project. It is always a good idea to check the continuity from one lead on the component side of the board to another connected lead. Indications of over one ohm will indicate likely poor soldering joints or broken lead paths. For one-of-a-kind or first-piece boards more detail may be called for since the board design can control the parameters of effects such as stray capacitance, inductance, and leakage between conductors. Finally, checks of the physical placement and for component damage during assembly is a good idea.

### Circuit Board Materials Suppliers

**Allied Chemical Corp.**, Box 70, Morristown, New Jersey 07960: printed-circuit etchants.

**By Buk**, 4326 West Pico Blvd., Los Angeles, Calif. 90019: electronic markings, pressure sensitive tapes, layout materials.

**Chart-Pak, Inc.**, One River Road, Leeds, Mass. 01053: electronic markings, pressure-sensitive tapes, layout materials.

**Cinch-Graphic Div.**, 200 S. Turnbull Canyon Rd., City of Industry, Calif. 91744: printed-circuit etchants, finished p.c. boards.

**Commercial Plastics and Supply Corp.**, 630 Broadway, N.Y.C. 10012: laminated board materials.

**Datak Corp.**, 63 71st St., Guttenberg, New Jersey 07093: electronic markings, pressure sensitive tapes, layout materials.

**Eastman Kodak Co.**, Department 454, Rochester, N.Y. 14650: photo resist, technical publications and information.

**Garlock Electronic Products**, 8 Fellowship Rd., Cherry Hill, New Jersey 08034: laminated board materials.

**General Electric Company, Inc.**, Laminated Products Dept., Coshocton, Ohio 43802: laminated board materials.

**Kepro Circuit Systems, Inc.**, 3630 Scarlet Oak Blvd., St. Louis, Mo. 63122: circuit-board kits, photo resist.

**Mica Corp.**, 4031 Elrenda St., Culver City, Calif. 90230: laminated-board materials.

**Mica Insulator Div. of 3M**, 801 Broadway, Schenectady, N.Y. 12305: laminated-board materials.

**Photocircuits Corp.**, Glen Cove, N.Y. and Anaheim, California: finished p.c. boards.

**Russel Industries, Inc.**, 96 Station Plaza, Lynbrook, N.Y. 11563: electronic markings, pressure-sensitive tapes, layout materials.

**Synthane Corp.**, 12 River Rd., Oaks, Pa. 19456: laminated-board materials.

**Ulano Corp.**, 610 Dean Street, Brooklyn, N.Y. 11238: masking films.

**Vector Electronics Co.**, 1100 Flower St. Glendale, Calif. 91201: photo resist, printed-circuit etchants, circuit-board kits, technical information.

Write to the individual companies for further information as well as local distributors of the product. Other good sources for additional materials are mail-order electronics supply catalogs.

# The Contributions of Edsel Murphy to the Understanding of the Behavior of Inanimate Objects

D. L. Klipstein

*This valuable contribution to the theoretical understanding of the engineer originally appeared in EEE Magazine. It is reprinted with their kind permission.*

*Consideration is given to the effects of the contributions of Edsel Murphy to the discipline of electronics engineering. His law is stated in both general and special form. Examples are presented to corroborate the author's thesis that the law is universally applicable.*

## I. Introduction

It has long been the consideration of the author that the contributions of Edsel Murphy, specifically his general and special laws delineating the behavior of inanimate objects, have not been fully appreciated. It is deemed that this is, in large part, due to the inherent simplicity of the law itself.

It is the intent of the author to show, by references drawn from the literature, that the law of Murphy has produced numerous corollaries. It is hoped that by noting these ex-

amples, the reader may obtain a greater appreciation of Edsel Murphy, his law, and its ramifications in engineering and science.

As well known to those versed in the state-of-the-art, Murphy's Law states that "If anything can go wrong, it will." Or, to state it in more exact mathematical form:

$$1 + 1 \approx 2 \quad (1)$$

where  $\approx$  is the mathematical symbol for hardly ever.

Some authorities have held that Murphy's Law was first expounded by H. Cohen<sup>1</sup> when he stated that "If anything can go wrong, it will — during the demonstration." However, Cohen has made it clear that the broader scope of Murphy's general law obviously takes precedence.

To show the all-pervasive nature of Murphy's work, the author offers a small sample of the application of the law in electronics engineering.

## II. General Engineering

II.1. A patent application will be preceded by one week by a similar application made by an independent worker.

II.2. The more innocuous a design change appears, the further its influence will extend.

II.3. All warranty and guarantee clauses become void upon payment of invoice.

II.4. The necessity of making a major design change

---

*Manuscript received April 17, 1967; revised June 3, 1967, additional revision March, 1968. The work reported herein has not been supported by grants from the Central Intelligence Agency.*

*The author is Director of Engineering at Measurement Control Devices, 2445 Emerald Street, Philadelphia, Pa.*

increases as the fabrication of the system approaches completion.

II.5. Firmness of delivery dates is inversely proportional to the tightness of the schedule.

II.6. Dimensions will always be expressed in the least usable terms. Velocity, for example, will be expressed in furlongs per fortnight.<sup>2</sup>

II.7. An important instruction manual or operating manual will have been discarded by the receiving department.

II.8. Suggestions made by the value analysis group will increase costs and reduce capabilities.

II.9. Original drawings will be mangled by the copying machine.<sup>3</sup>

### III. Mathematics

III.1. In any given miscalculation, the fault will never be placed if more than one person is involved.

III.2. Any error than can creep in, will. It will be in the direction that will do the most damage to the calculation.

III.3. All constants are variables.

III.4. In any given computation, the figure that is most obviously correct will be the source of error.

III.5. A decimal will always be misplaced.

III.6. In a complex calculation, one factor from the numerator will always move into the denominator.

### IV. Prototyping and Production

IV.1. Any wire cut to length will be too short.

IV.2. Tolerances will accumulate unidirectionally toward maximum difficulty of assembly.

IV.3. Identical units tested under identical conditions will not be identical in the field.

IV.4. The availability of a component is inversely proportional to the need for that component.

IV.5. If a project requires  $n$  components, there will be  $n-1$  units in stock.<sup>4</sup>

IV.6. If a particular resistance is needed, that value will not be available. Further, it cannot be developed with any available series or parallel combination.<sup>5</sup>

IV.7. A dropped tool will land where it can do the most damage. (Also known as the law of selective gravitation.)

IV.8. A device selected at random from a group having 99% reliability, will be a member of the 1% group.

IV.9. When one connects a 3-phase line, the phase sequence will be wrong.<sup>6</sup>

IV.10. A motor will rotate in the wrong direction.<sup>7</sup>

IV.11. The probability of a dimension being omitted from a plan or drawing is directly proportional to its importance.

IV.12. Interchangeable parts won't.

IV.13. Probability of failure of a component, assembly, subsystem or system is inversely proportional to ease of repair or replacement.

IV.14. If a prototype functions perfectly, subsequent production units will malfunction.

IV.15. Components that must not and cannot be assembled improperly will be.

IV.16. A d.c. meter will be used on an overly sensitive range and will be wired in backwards.<sup>8</sup>

IV.17. The most delicate component will drop.<sup>9</sup>

IV.18. Graphic recorders will deposit more ink on humans than on paper.<sup>10</sup>

IV.19. If a circuit cannot fail, it will.<sup>11</sup>

IV.20. A fail-safe circuit will destroy others.<sup>12</sup>

IV.21. An instantaneous power-supply crowbar circuit

will operate too late.<sup>13</sup>

IV.22. A transistor protected by a fast-acting fuse will protect the fuse by blowing first.<sup>14</sup>

IV.23. A self-starting oscillator won't.

IV.24. A crystal oscillator will oscillate at the wrong frequency — if it oscillates.

IV.25. A pnp transistor will be an npn.<sup>15</sup>

IV.26. A zero-temperature-coefficient capacitor used in a critical circuit will have a TC of  $-750/^{\circ}\text{C}$ .

IV.27. A failure will not appear till a unit has passed final inspection.<sup>16</sup>

IV.28. A purchased component or instrument will meet its specs long enough, and only long enough, to pass incoming inspection.<sup>17</sup>

IV.29. If an obviously defective component is replaced in an instrument with an intermittent fault, the fault will reappear after the instrument is returned to service.<sup>18</sup>

IV.30. After the last of 16 mounting screws has been removed from an access cover, it will be discovered that the wrong access cover has been removed.<sup>19</sup>

IV.31. After an access cover has been secured by 16 hold-down screws, it will be discovered that the gasket has been omitted.<sup>20</sup>

IV.32. After an instrument has been fully assembled, extra components will be found on the bench.

IV.33. Hermetic seals will leak.

### V. Specifying

V.1. Specified environmental conditions will always be exceeded.

V.2. Any safety factor set as a result of practical experience will be exceeded.

V.3. Manufacturers' spec sheets will be incorrect by a factor of 0.5 or 2.0, depending on which multiplier gives the most optimistic value. For salesmen's claims these factors will be 0.1 or 10.0.

V.4. In an instrument or device characterized by a number of plus-or-minus errors, the total error will be the sum of all errors adding in the same direction.

V.5. In any given price estimate, cost of equipment will exceed estimate by a factor of 3.<sup>21</sup>

V.6. In specifications, Murphy's Law supersedes Ohm's.

### References\*

- [1] H. Cohen, Roundhill Associates, private communication.
- [2] P. Birman, Kepco, private communication.
- [3] T. Emma, Western Union, private communication.
- [4] K. Sueker, Westinghouse Semiconductor, private communication.
- [5] — — —, *loc cit.*
- [6] — — —, *loc cit.*
- [7] — — —, *loc cit.*
- [8] P. Muchnick, Sorensen, private communication.
- [9] A. Rosenfeld, Micro-Power, private communication.
- [10] P. Muchnick, *loc cit.*
- [11] R. Cushman, McCann/ITSM, private communication.
- [12] — — —, *loc cit.*
- [13] — — —, *loc cit.*
- [14] S. Froud, Industrial Communications Associates, private communication.
- [15] L. LeVieux, Texas Instruments, private communication.
- [16] G. Toner, Sylvania, private communication.
- [17] H. Roth, Power Designs, private communication.
- [18] W. Buck, Marconi Instruments, private communication.
- [19] A. de la Lastra, SBD Systems, private communication.
- [20] — — —, *loc cit.*
- [21] P. Dietz, Data Technology, private communication.

\*In some cases where no reference is given, the source material was misplaced during preparation of this paper (another example of Murphy's Law). In accordance with the law, these misplaced documents will turn up on the date of publication of this paper.

# Motion-Picture Sound Systems

L. A. Wortman

*The modern motion-picture theater uses highly sophisticated sound systems. This historical and current-state report details Ampex' activities in this field.*

**T**HE rasping voice of Al Jolson was immortalized in 1927 in *The Jazz Singer*, the first motion picture employing sound. If Jolson could have foreseen the quality of motion-picture sound today as compared to his era, he probably would have repeated his famous phrase, "You ain't seen nothin' yet."

Magnetic audio recording was introduced by Ampex Corporation in 1947 — and soon thereafter adopted for theater sound. Master tracks of motion pictures were recorded on magnetic tape, then transferred to optical recording systems for playback. Optical sound offered an improvement in sound quality over disc reproduction, which was used for the first motion picture sound tracks.

With magnetic tape came the opportunity for stereophonic sound in theaters. *House of Wax*, a 1951 three-dimensional feature, was the first picture released to use a form of magnetically recorded stereophonic sound. Separate film reels carried picture and sound, with the sound reel containing imageless film coated with an iron oxide.

In 1953, Ampex, working closely with several motion-picture studios, introduced the first true stereo theater sound system. The system made its premiere nationally with the showing of *The Robe*.

The motion-picture industry quickly accepted this system as its standard for high-quality theater sound. Since *The Jazz Singer*, there had been little change in sound-track recording, and the industry was attracted by the advantages of four-channel multidirectional systems with the superior sound of magnetic recording. Another advance, the six-channel magnetic sound system, was developed by Ampex in 1955. For this the Motion Picture Academy of Arts and Sciences presented Ampex an Oscar award.

*Oklahoma*, released in 1955, was the first movie produced with the Todd A-O process, which used 70mm film instead of 35mm, and six channels of sound instead of four. Five

speakers were located behind the screen, and effects speakers drawing from the sixth audio channel were placed on walls of the theater surrounding the audience. Six separate sound tracks, each 100 mil in width, gave *Oklahoma* much better sound reproduction than the standard 50 mill tracks. When first released, the film was shown with separate film and sound tracks. Within six months, sound striping was added to the composite prints.

All theater sound systems employed vacuum tubes until the early 1960s, when solid-state components appeared. Initially, solid-state components often were unreliable because they had not been originally designed for use in theater sound systems, but instead were adapted from other sources. At this time Ampex introduced a line of solid-state components specifically designed for high-quality theater sound reproduction and other commercial-sound applications.

The preamplifier was developed from the solid-state Ampex AG-440 line of professional audio recorders. For theater sound systems, we produce magnetic, optical, phonograph, and microphone preamplifiers. Each has its own equalization and gain controls, and each has a transformer output to balance the output line and to provide ground isolation. Each unit is powered by dual regulated 39.5-volt power supplies, providing all preamplifiers with standby supplies. The one-watt power output capability is four times above what is generally considered necessary. Working so far below overload gives the operator a very clean signal.

The model APM-1 preamplifier modules accept inputs from microphones and phonographs, and the Model APF Series preamplifier modules accept inputs from magnetic-head devices such as tape recorders and motion-picture sound tracks. A line amplifier is self-contained in each of the preamp modules, but the input circuitry is varied in each one to match the transducer employed. The model APT-8 preamp trays will accept up to eight preamplifiers and the Model PS power supplies will feed up to 16 preamps.

This theater sound system continues to use the same pre-amp switching unit popular for many years. This unit is a simple Ledex-operated rotary solenoid-switch mechanism

---

L. A. Wortman is marketing manager of professional audio products for Ampex Corporation.





Figure 1. The Century 21 theater in San Jose, California features four racks of a six-channel magnetic theater sound system. This installation has the older vacuum-tube model, which has since been replaced by solid-state units.

which is used to allow complete remote operation. By incorporating a preamp for each head and switching at the output at high level, switching noises are eliminated. Sound from one projector may be transferred to another without the audience sensing the changeover. Although other switching techniques are available, none to date has improved upon the reliability, repeatability and noise-free operation of these switches. The preamp switch selects mode and projector remotely from the station control near the projector.

A frequency response of  $\pm 1$  dB 30 to 20,000 Hz at full output is guaranteed for the Model AH-80 power amplifiers. They are fully protected against failure due to overloading, short circuits, or unexpected power surges. To accomplish this, two fuses are provided — one for short-circuit protection, and one to prevent excessive instantaneous power such as is experienced in the loss of an input ground. One-quarter-volt of input signal is required to drive the power amplifier to an 80-watt output. The power amplifier is 7-inches high, while the preamp trays and preamp power supply each are 3½-inches high. All units are designed for mounting in a standard 19-inch rack.

The amplifier provides 80 watts of continuous power, well above normal needs. This prevents failure, common to early solid-state power amplifiers, due to the operating level being too near the maximum power level.

A standby unit can be switched into service for any power amplifier which has failed. A switch also provides built-in dummy loads for testing. Plug-in accessories for the 80-watt, solid-state amplifier include a dummy card for flat

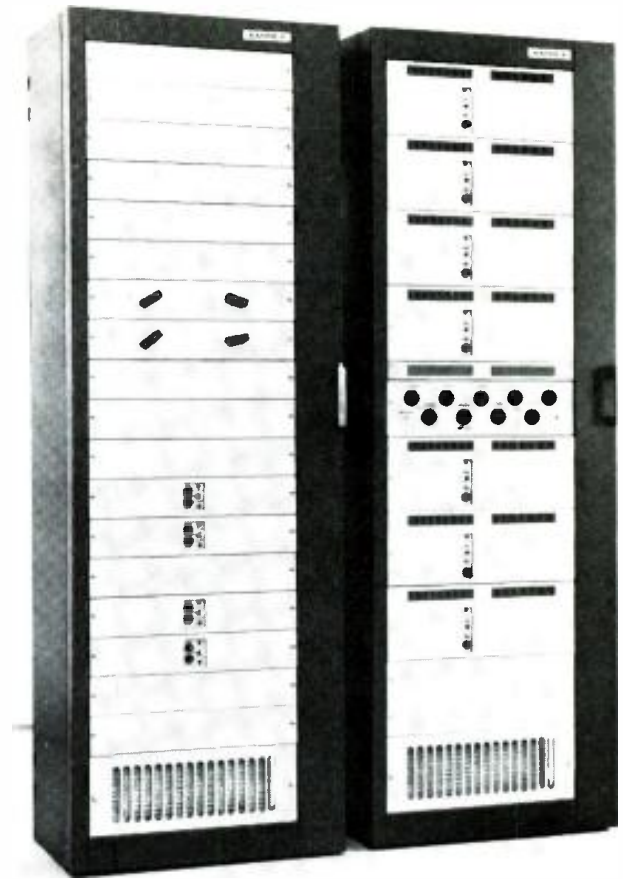

Figure 2. The eight-channel theater sound system developed for Dimension-150. It includes solid-state electronics and occupies about half the space of previous systems. The selector switches on the upper part of the left unit can be moved to AUXILIARY, MULTI-TRACK MAGNETIC, 4-TRACK MAGNETIC, OPTICAL, and NON-SYNC selection.

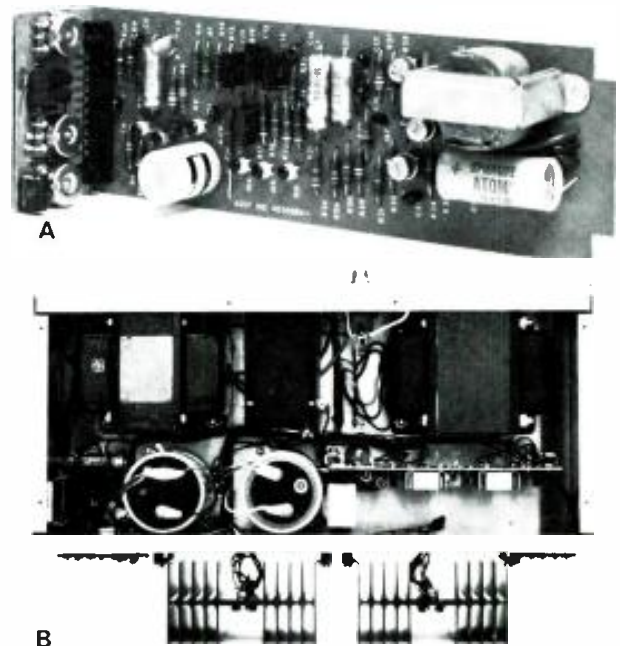

Figure 3. (A) This solid-state plug-in preamplifier offers a one-watt power output capacity. In (B) the 80-watts continuous power amplifier is shown.

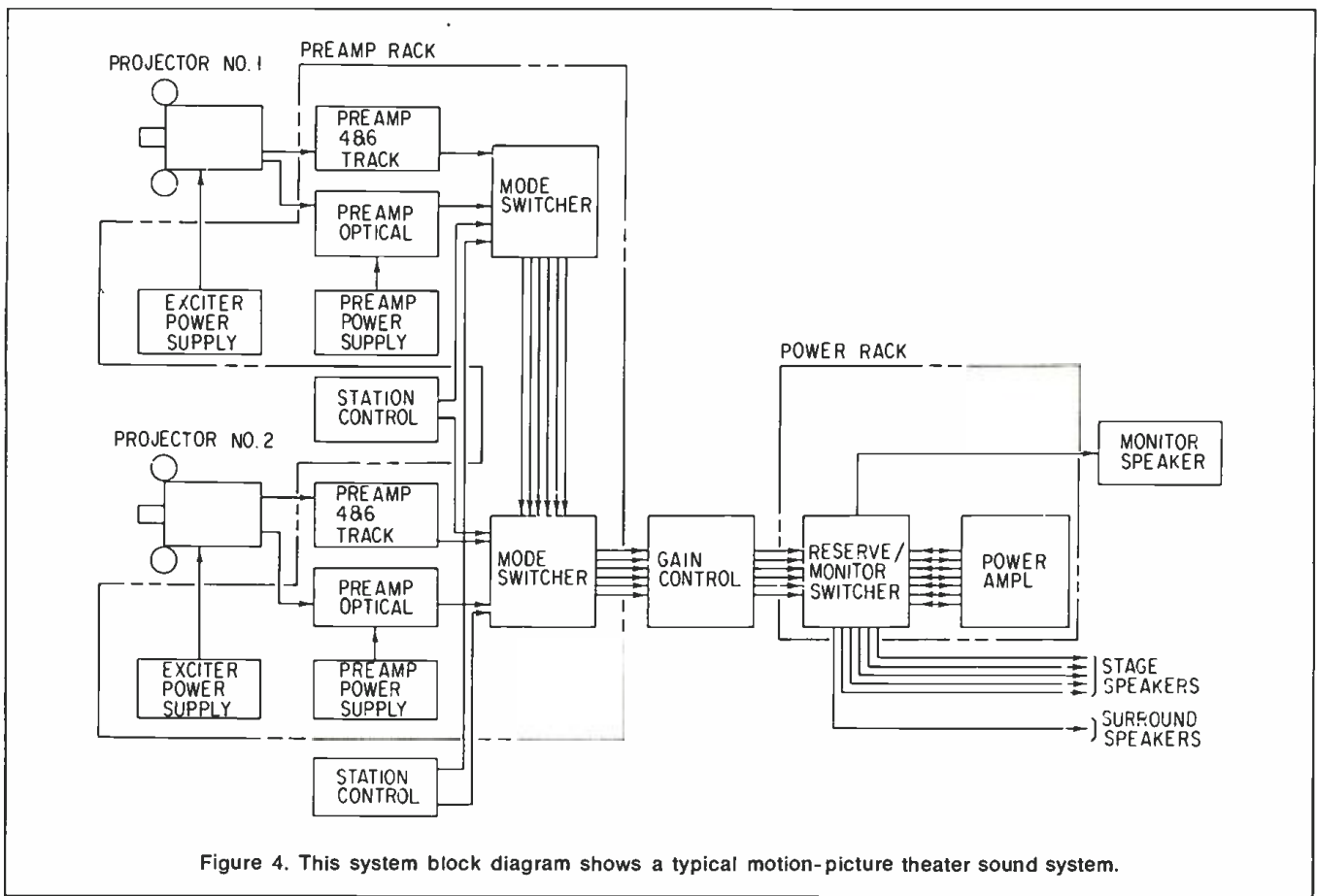

Figure 4. This system block diagram shows a typical motion-picture theater sound system.

response, a high- and low-frequency equalizer with or without a presence equalizer, a microphone preamplifier, a phono preamp, a 600-ohm line bridging transformer, and a 600-ohm line matching transformer. These options offer greater utility for the power amplifier.

An 80-volt dual power supply (one-half standby) powers the Ledex drive to the preamp switcher. This dual supply is in addition to the 39.5-volt preamp power supplies.

A well-filtered 10-volt d.c. supply energizes the exciter lamp used on optical tracks. Its standby feature permits an operator to switch to a.c. if there is a supply failure.

In 1967, we developed an eight-channel solid-state theater sound system for use with the versatile new D-150 All Purpose Projection System developed by Dimension-150, Inc. The system occupies about half the space of previous systems.

In the D-150 process, five speaker systems are located behind the stage, with three banks of effects speakers surrounding the theater audience. In six-channel systems, all surround speakers derive their signals from one audio track, while the D-150 eight-channel system has three separate channels to drive the surround speakers. These channels provide more subtle control and flexibility of the individual surround channel to enhance the emotional effects.

The picture-screen width of conventional 35mm film (1.85:1 aspect ratio) is 40 feet. For 35mm anamorphic systems (Cinemascope, Panavision, etc.) the width is 47 feet. Conventional 70mm screen width (Todd A-O, Ultra Panavision, Super Technirama, etc.) is 53 feet. Dimension-150 uses a 70-foot wide screen. This last figure is variable, depending upon the geometry of the theater, since the width of auditoriums, ceiling height, and length of throw must be considered.

Despite the deep curvature of the screen, the D-150 process eliminates the problem of cross-reflection, while increasing contrast and color-saturation. The lenses introduce mild rectification of the image to permit distortion-free viewing. Sixteen foot-lamberts of light are returned to the viewer. The gain factor is approximately two.

Lenses range from 150-degree to extreme telephoto. The field of a 150-degree lens approximates the human binocular field of view — it includes essentially everything a person would see if he were standing at the camera's vantage point.

D-150's motorized screen masking system is controlled by simple push-button selection at each projection operating station. Separate adjustments for top masking and side masking provide an unlimited variety of picture widths and heights. Duplicate control panels are provided to operate screen masking and the curtain from a backstage location, should the need arise. Screen frame, curtain, and masking tracks all are combined into a self-contained package.

In addition to the eight-channel system, a six-channel system exists for 35mm films. Either four-channel magnetic or single-channel optical sound is available for indoor theaters. (Drive-in theaters only use single-channel optical systems.) 70mm films always use at least a six-channel system. Large-scale sound systems are available that reproduce all of these combinations.

It appears that the most significant improvement foreseeable for theater sound systems in the near future lies in the field of automated control of projection, screen and audio systems. The continuing process of miniaturization and simplification will mean more technical versatility, reliability and maintainability for theater operators and consistent listening pleasure for their customers.

# 34th AES Convention

## Los Angeles, California

### April 29-May 2, 1968

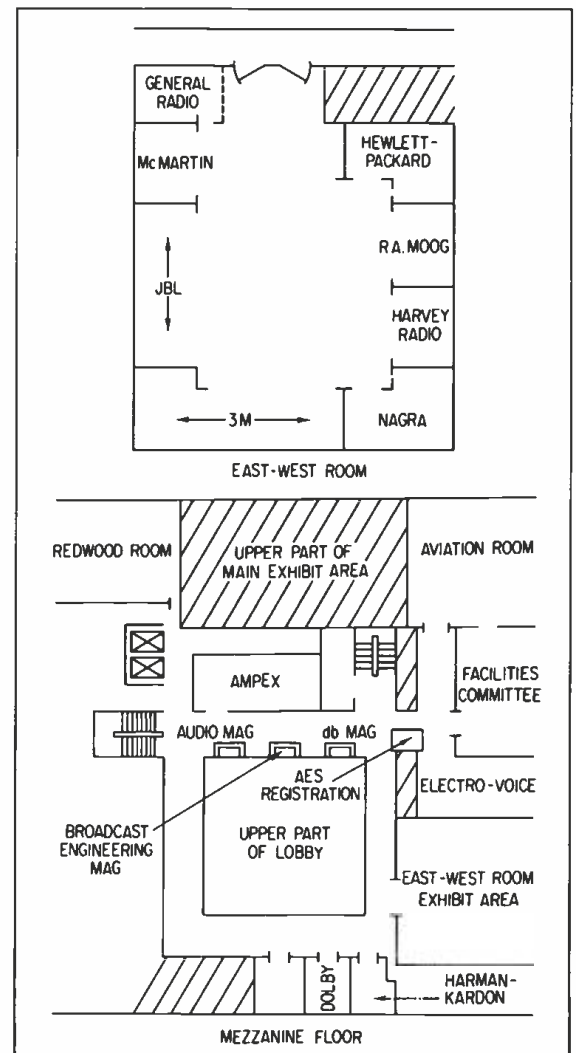
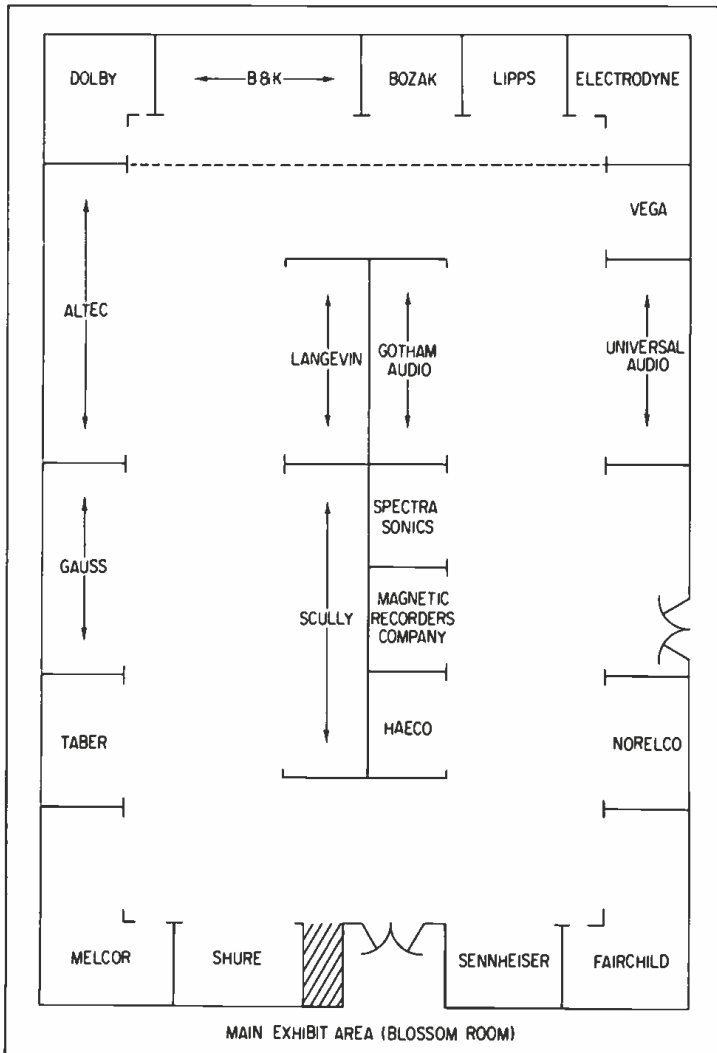

## QUICK SUMMARY

### Registration

*Mezzanine, Hollywood Roosevelt Hotel*  
Monday, April 29 through Thursday, May 2, 1968—  
9:30 A.M. to 8:00 P.M.

### Banquet

*Aviation Room*  
Wednesday, May 1, 1968  
Social Hour—6:30 P.M.  
Banquet—7:30 P.M.

### Technical Sessions

*Aviation Room*  
MONDAY, APRIL 29  
10:00 A.M.—Amplifiers, FET  
1:30 P.M.—Amplifiers, General  
7:30 P.M.—Transducers  
TUESDAY, APRIL 30  
9:30 A.M.—Tape Cartridge Systems  
1:30 P.M.—Recording  
7:30 P.M.—Sound Reinforcement  
WEDNESDAY, MAY 1  
9:30 A.M.—Acoustics and Hearing  
1:30 P.M.—Instrumentation  
THURSDAY, MAY 2  
9:30 A.M.—Recording and Broadcasting  
1:30 P.M.—Music and Speech  
7:30 P.M.—Audio Applications

### Exhibits

Monday through Thursday, April 29 through  
May 2, 1968  
*Hollywood East-West Room*  
*Blossom Room*  
*Conference Room C, E, F*  
*Boulevard Room*  
Monday and Tuesday—1:00 P.M. to 9:00 P.M.  
Wednesday and Thursday—1:00 P.M. to 5:00 P.M.

## THE PAPERS

### Amplifiers, FET

10:00 A.M.—Monday, April 29, 1968  
Chairman: JAMES F. KANE, *Motorola, Inc., Semiconductor Products Division, Phoenix, Arizona.*  
**FET Temperature Characteristics**—John C. Sinclair, Zenith Radio Corp., Chicago, Illinois  
**A Self-Contained Condenser Microphone Using a Solid Electrolyte Battery for Permanent Polarization**—Alan Dager and Charles F. Swisher, Vega Electronics Corporation, Santa Clara, California  
**The "BI-FET" and Its Circuit Applications**—David R. Pryce, Ampere Electronics Corporation, Cranston, Rhode Island  
**The Audio Behavior of Integrated MOS Devices**—James F. Kane, Motorola, Inc., Semiconductor Products Division, Phoenix, Arizona

### Amplifiers—General

1:30 P.M.—Monday, April 29, 1968  
Chairman: JAMES J. NOBLE, *Altec Lansing, A Division of LTV Ling Altec, Inc., Anaheim, California.*  
**Frequency Controlled AGC In Small Signal Audio Amplifiers**—William H. Greenbaum and Iraj Gharib, Zenith Radio Corp., Chicago, Illinois  
**New Solid State Amplifier for the Recording Industry**—Vernon B. Bushway, Jr., RCA Broadcast & Communications Division, Burbank, California  
**Modular Transistorized Volume Limiting Amplifier**—Walton N. Hershfield, Nelson Hershfield Electronics Company, Phoenix, Arizona  
**Applications of the Audio Operational Amplifier To Studio Use**—D. L. Richter, Melcor Electronics Corporation, Farmingdale, New York  
**A Low-Noise Amplifier with An FET Compression Circuit**—David L. Campbell, Fairchild Semiconductor, Inc., Mountain View, California  
**Modern Music—Rock, Jazz, Pop—and the Amplifier Designer's Dilemma**—Paul B. Spranger, Altec Lansing, Anaheim, California  
**Operational Amplifier Applications for Audio Systems**—B. J. Losmandy, Opamp Labs, Los Angeles, California  
**A Highly Refined Lamp-Photocell Automatic Level Control Device Having Fast Attack Time, Instantaneous Transient Release and Low Distortion**—William Ross Aiken, Vega Electronics Corporation, Santa Clara, California

### Transducers

7:30 P.M.—Monday, April 29, 1968  
Chairman: GEORGE L. AUGSPURGER, *James B. Lansing Sound, Inc., Los Angeles, California.*  
**Dragon — A Pyroacoustic Transducer**—James S. Arnold and Vincent Salmon, Stanford Research Institute, Menlo Park California (Mr. Arnold is now affiliated with McDonnell Douglas Corp.)  
**Speaker System Design Using A Reverberation Chamber**—Victor Brociner, H. H. Scott, Inc., Maynard, Massachusetts  
**Frequency Modulation Distortion In Loudspeakers**—Paul W. Klipsch, Klipsch and Associates, Inc., Hope, Arkansas  
**Recent Speaker System Developments To Meet the Dynamic and Power Requirements of Amplified Musical Instruments**—William L. Hayes, Altec Lansing, Anaheim, California  
**Methods of Rating Power Capacity of Cone-Type Loudspeakers**—Bart N. Locanthi, James B. Lansing Sound, Inc., Los Angeles, California  
**Long Time Sensitivity of Foil-Electret Microphones**—G. M. Sessler and J. E. West, Bell Telephone Laboratories, Incorporated, Murray Hill, New Jersey  
**Electret Condenser Microphones of High Quality and Reliability**—Preston V. Murphy, Thermo Electron Corporation, Waltham, Massachusetts  
**A 3-Way Columnar Loudspeaker System**—R. T. Bozak, The R. T. Bozak Mfg. Co., South Norwalk, Connecticut

## Tape Cartridge Systems

9:30 A.M.—Tuesday, April 30, 1968

Chairman: PELL KRUTTSCHNITT, *Capitol Records, Hollywood, California.*

**A 150 Mil Slave Transport for Cassette Duplication**—Donald Kahn, 3M Company, Camarillo, California  
**Mass Production of Pre-recorded Tapes**—Thomas D. Everett, Ampex Corporation, Elk Grove Village, Illinois

**Design Considerations and Objectives In the Design and Development of an Automatic Stereo Cassette Changer and A Compact Stereo Cassette Playback Unit**—Edward R. Hanson, North American Philips Co., Inc., New York, New York

**The Newell Principle In Tape Cartridge Systems**—C. W. Newell, Newell Industries, Sunnyvale, California  
**High Speed .150" Tape Duplication System**—Richard Millward, Ampex Special Products Department, Redwood City, California

## Recording

1:30 P.M.—Tuesday, April 30, 1968

Chairman: CHARLES PRUZANSKY, *RCA Victor Record Division, North Hollywood, California.*

**The Scanning Electron Microscope—A New Tool In Disc Recording Research**—J. G. Woodward, M. D. Coutts and E. R. Levin, RCA Laboratories, Princeton, New Jersey

**Splicing Tapes and Their Proper Applications**—Delos A. Eilers, 3M Company, Magnetic Products Laboratory, St. Paul, Minnesota

**Polyester and Acetate As Magnetic Tape Backings**—Delos A. Eilers, 3M Company, Magnetic Products Laboratory, St. Paul, Minnesota

**An Improved, Low Crosstalk Recording Head Designed for Sync Playback**—Warren B. Dace, Lipps, Inc., Santa Monica, California

**Remote Control of the Overdub or Sync Operation of A Multichannel Recorder**—Dale Manquen, 3M Company, Camarillo, California

**New Compact Electronics for A Professional Audio Recorder**—Dale Manquen, 3M Company, Camarillo, California

**Precision Alignment and Quality Control Techniques For Many Channel Recorders Operating At Short Wavelengths**—Keith O. Johnson, Gauss Electro-physics, Inc., Santa Monica, California

**Synchronous Sound For Motion Pictures**—Ronald R. Cogswell, Ryder Magnetic Sales Corporation, Hollywood, California

**A "How-To" Review of Disc Recording Practices — Stereo and Mono**—Stephen F. Tenmer, Gotham Audio Corporation, New York, New York

**the last time you used a 'scope,  
did you really need more performance  
than these Heathkit® models provide?**



**IO-17 SPECIFICATIONS — VERTICAL CHANNEL:** Input impedance: 1 megohm shunted by 25 pF; x 50 attenuator position 1 megohm shunted by 15 pF. Sensitivity: 30mV P-P/div. (uncalibrated). Frequency response: 5Hz to 5MHz  $\pm 3$  dB. **HORIZONTAL CHANNEL:** Input impedance: 10 megohm shunted by 15 pF. Sensitivity: 300 mV P-P/div. Frequency response: 2Hz to 300 kHz  $\pm 3$  dB. **HORIZONTAL SWEEP GENERATOR:** Sweep generator: Recurrent type. Frequency: 20Hz to 200 kHz in four overlapping ranges. Retrace: Blanked by a pulse from blanking amplifier. Synchronization: Automatic type. **GENERAL:** Tube complement: (1) 3RPI cathode ray tube, medium persistence, green trace; (3) 12AU7; (1) 12AX7; (1) 6GB; (1) 68M6; (1) 68Q7. Power requirements: 105-125 volts 50/60 Hz or 210-250 volts 50/60 Hz. Power consumption: 60 watts. Overall dimensions: 9 $\frac{1}{2}$ " H x 5 $\frac{1}{2}$ " W x 14 $\frac{1}{2}$ " L. (Dimensions include handle, knobs, etc.). Net weight: 12 lbs.



**IO-14 SPECIFICATIONS — (VERTICAL)** Sensitivity: 0.05 V/cm AC or DC. Frequency Response: DC to 5 MHz — 1 dB or less; DC to 8 MHz — 3 dB or less. Rise time: 40 nsec (0.04 microseconds) or less. Input impedance: 1 megohm shunted by 15 pF. Signal delay: 0.25 microsecond. Attenuator: 9-position, compensated, calibrated in 1, 2, 5 sequence from 0.05 V/cm to 20 V/cm. Accuracy:  $\pm 3\%$  on each step with continuously variable control (uncalibrated) between each step. Maximum input voltage: 600 volts peak-to-peak; 120 volts provides full 6 cm pattern in least sensitive position. **(HORIZONTAL)** Time base: Triggered with 18 calibrated rates in 1, 2, 5 sequences from 0.5 sec/cm to 1 microsecond/cm with  $\pm 3\%$  accuracy or continuously variable control position (uncalibrated). Sweep magnifier: X5, so that fastest sweep rate becomes 0.2 microsecond/cm with magnifier on. (Overall time-base accuracy  $\pm 5\%$  when magnifier is on.) **Triggering capability:** Internal, external, or line signals may be switch selected. Switch selection of + or — slope. Variable control on slope level. Either AC or DC coupling. "Auto" position. **Triggering requirements:** Internal; 0.5 cm to 6 cm display. External; 0.5 volts to 120 volts peak-to-peak. **Triggering frequency response:** DC to 2.5 MHz approx. Horizontal input: 1.0 v/cm sensitivity (uncalibrated) continuous gain control. Bandwidth: DC to 200 kHz  $\pm 3$  dB. Power requirements: 285 watts, 115 or 230 VAC 50-60 Hz. Cabinet dimensions: 15" H x 10 $\frac{1}{2}$ " W x 22" D includes clearance for handle and knobs. Net weight: 40 lbs.



### FREE 1968 CATALOG

Describes these and over 300 kits for stereo/hi-fi, color TV, amateur radio, shortwave, test, CB, marine, educational, home and hobby. Save up to 50% by doing the easy assembly yourself. Mail coupon or write Heath Company, Benton Harbor, Michigan 49022.

**HEATH COMPANY, Dept. 74-4**  
Benton Harbor, Michigan 49022

- Enclosed is \$ \_\_\_\_\_, plus shipping  
Please send model (s) \_\_\_\_\_  
 Please send FREE Heathkit Catalog.  
 Please send Credit Application.

Name \_\_\_\_\_ (Please Print)

Address \_\_\_\_\_

City \_\_\_\_\_ State \_\_\_\_\_ Zip \_\_\_\_\_

Prices & specifications subject to change without notice. TE-178

Circle 19 on Reader Service Card

## Sound Reinforcement

7:30 P.M.—Tuesday, April 30, 1968

Chairman: ROLF HERTENSTEIN, *DuKane Corporation, Anaheim, California.*

**Professional Quality Sound Systems for School Auditoriums** — W. R. Torn, DuKane Corporation, St. Charles, Illinois

**Trends In Sound Reproduction Research**—Harry F. Olson, RCA Laboratories, Princeton, New Jersey

**A 1/3 Octave Filter Set For Equalization of Sound Reinforcement Systems** — Don Davis, Altec Lansing, Anaheim, California

**New Method For Evaluating the Effectiveness of Sound Amplification Systems In Reverberant Spaces**—J. Jacek Figwer, Bolt Beranek & Newman Inc., Cambridge, Massachusetts

**Audio and Acoustical Instrumentation As Used By A Sound Contractor** — Carl Colip, Jr., Commercial Electronics, Inc., Indianapolis, Indiana

**An Audio Video System Designed By A Sound Contractor As An Integral Laboratory Tool For Research In Human Behavior** — C. M. McLaughlin and R. F. Behrendt, Service-Master Communications, Inc. — Boom Sound Engineering, Inc., Chicago, Illinois

**The Effects Of Detailed Equalization On Contemporary Sound Reinforcement System Design** — David L. Klepper, Bolt Beranek and Newman, Inc., Downers Grove, Illinois

**Sound Reinforcement System for the New York Philharmonic and Metropolitan Opera New York City Parks Concerts** — Christopher Jaffe, Christopher Jaffe & Associates, Inc., San Francisco, California

## Acoustics and Hearing

9:30 A.M. — Wednesday, May 1, 1968

Chairman: A. R. SOFFEL, *LTV Research Center, Anaheim, California.*

**Statistics of Delayed Reflections** — Michael Rettinger, Consultant on Acoustics, Encino, California

**Reverberation Measurement by the Automatic-Decay Rate Meter and Other Methods** — F. K. Harvey, Bell Telephone Laboratories, Incorporated, Murray Hill, New Jersey

**Instant Recording Studios Using Prefabricated Acoustical Panels** — Allan P. Smith, Naval Training Device Center, Orlando, Florida

**Image Fusion Requirements of the (Haas) Precedence Effect** — Mark B. Gardner, Bell Telephone Laboratories, Incorporated, Murray Hill, New Jersey

**Noise Rating and Hearing Impairment**—Aram Glorig, M.D., Callier Hearing and Speech Center, Dallas, Texas

**Some Effects of Interference on Speech Intelligibility** — William B. Snow, The Bissett-Berman Corporation, Santa Monica, California

## Instrumentation

1:30 P.M. — Wednesday, May 1, 1968

Chairman: ALLEN E. BYERS, *United Recording Electronics Industries, North Hollywood, California.*

**Solid State Condenser Measuring Microphone Assembly** — W. T. Kapuskar, Research and Development, Hewlett-Packard GmbH, Boblingen, Germany

**A One Third Octave Universal Frequency Response Shaper** — Bernard Katz, B & K Instruments, Inc., Cleveland, Ohio

**Survey of Methods of Vibration Analysis** — Dennis Dinga, Cameron G. Pierce & Associates, South Pasadena, California on behalf of Spectral Dynamics, San Diego, California

**Transmission Measuring Sets** — Arthur C. Davis, Altec Lansing, Anaheim, California

**Methodology For Acoustical Data Gathering** — Benjamin B. Bauer, Bert A. Bodenheimer and Edward J. Foster, CBS Laboratories, Stamford, Connecticut

**High Speed Automated Test System** — Daniel A. Roberts, Gates Radio Company, Quincy, Illinois

**The Need To Hear Ourselves As Others Hear Us** — Richard W. Burden, Richard W. Burden Associates, Mount Kisco, New York

## Recording and Broadcasting Facilities

9:30 A.M. — Thursday, May 2, 1968

Chairman: WILLIAM G. DILLEY, *Spectra Sonics, Ogden, Utah.*

**A High Performance Control Console With Flexibility** — Allan P. Smith, Naval Training Device Center, Orlando, Florida

**Active Isolation "Transformers" in Studio Console Design** — William G. Dilley, Spectra Sonics, Ogden, Utah

**A Functional Audio Control System That Meets The Professional Audio Engineer's Responsibility To The Industry** — Hardy Martin, Sambo Sound Studios, Louisville, Kentucky

**Versatile Audio Control Console** — Donald McLaughlin, Electrodyne Corporation, North Hollywood, California

**A Mobile Electro-Acoustic Laboratory** — Allan P. Smith, Naval Training Device Center, Orlando, Florida

## Music and Speech

1:30 P.M. — Thursday, May 2, 1968

Chairman: M. V. MATHEWS, *Bell Telephone Laboratories Incorporated, Murray Hill, New Jersey.*

**Some Time Dependent Characteristics of Cornet, Oboe, and Flute Tones** — James W. Beauchamp, University of Illinois, Urbana, Illinois

**Sound Production in the Wind Instruments** — John Backus, University of Southern California, Los Angeles, California

**An Algorithm For Segmentation of Connected Speech** — D. R. Reddy and P. J. Vicens, Stanford University, Stanford, California

**Preprocessing of Speech for Added Intelligibility in High Ambient Noise** — Ian B. Thomas and Russell J. Niederjohn, University of Massachusetts, Amherst, Massachusetts

**A Symbolic Approach to Musical Composition** — L. Knopoff, Institute of Ethnomusicology, University of California, Los Angeles, California

**The Relevance of Musical Theory to Musical Data-Processing** — Michael Kassler, Washington, D. C.

**The Stanford System for On-Line Generation of Sound By Computer** — David Poole, John Chowning and Leland Smith, Stanford University, Palo Alto, California

**Musical Signal Processing For Fun And Profit** — Robert A. Moog, R. A. Moog Co., Trumansburg, New York

## Audio Applications

7:30 P.M. — Thursday, May 2, 1968

Chairman: KEITH O. JOHNSON, *Gauss Electro-physics, Inc., Santa Monica, California.*

**Improved Performance Capabilities of Wireless Microphones** — Charles F. Swisher, Vega Electronics Corporation, Santa Clara, California

**Two Inch 16 and 24 Track Master Recorders** — Robert P. Harshberger, Jr., Ampex Special Products Department, Redwood City, California

**Random Access Audio System** — Maynard J. Kuljian, Ampex Special Products Department, Redwood City, California

Moderator: KEITH O. JOHNSON, *Gauss Electro-physics, Inc. Santa Monica, California*

**Audio Quality And Its Deterioration: Electronic and Subjective**

Panel: Allen E. Byers, United Recording Electronics Industries, North Hollywood, California

John M. Eargle, RCA Victor Records Division, New York, New York

John T. Mullin, 3M Company Mincom Division, Camarillo, California

Carl S. Nelson, Capitol Records, Hollywood, California

## New Products and Services

### Portable Mixer



● A stereo studio in an attache case is the billing given to this new six-channel stereo mixer, the model PM-1. Designed for professional recording and broadcasting use, the unit stresses compactness — the attache case is 18 x 12¼ x 5½ inches — and light weight — 25 lbs. As such it becomes ideal for hard-to-get-to remotes as well as functioning as a stand-by system that has the capability to provide full production output. Features include low-noise circuitry, transformer-coupled output, illuminated vu meters, plug-in circuitry, and a removable cover for easy control accessibility. XLR connectors on the top left of the panel are an added convenience. Phono preamps, tape-head preamps, high- or low-gain mics, line isolation transformers, high output line amp, and vu meter calibration networks may be plugged in. *Mfg: Gately Electronics*  
*Price: \$469.50 complete, with no preamps.*  
*\$695.00 with six mix preamps.*  
*Circle 50 on Reader Service Card*

### Monitor Speaker System



● The Rectilinear III four-way system produces an extreme clarity of wide-range sound. The low-frequency reproducer uses a 10-lb, magnetic structure for maximum concentration of flux density. A butylized surround permits 1-in. cone excursions. The mid-range driver is encapsulated in a special non-resonant fiber chamber. A secondary dispersion cone aids in diffusion. The high frequencies are split between two pairs of speakers. All drivers are bonded to the front panel with epoxy resin for maximum rigidity and tightness. Specifications include: frequency response, ±4 dB from 22-18,500 Hz; power capability, up to 100 watts r.m.s.; impedance, 8Ω. Dimensions are 35 in. x 18 in. x 12-in. deep. Weight is 65 lbs. Wood finish is oiled walnut. *Mfg: Rectilinear Research*  
*Price: \$279.00*  
*Circle 52 on Reader Service Card*

## For All Your Recording Tape Needs

*We carry a full line of Scotch—BASF—Irish tapes. Write for our free tape list. Lowest prices. Fast delivery from stock*

### Audio Unlimited

715 Second Ave., New York, N.Y. 10016

Circle 21 on Reader Service Card



● A model 400A unit, connected between the mixer output and the power amplifier input of a sound reinforcement system, allows 6 to 12 dB more gain before feedback ringing occurs in a hall — the exact amount to be determined by the characteristics of the hall. The unit works by shifting the spectrum upwards in frequency — normally by 5 Hz. A chassis knob permits varying the actual frequency of shift for unusual halls. In use, the signal is mixed with a stable 19.805

kHz tone and heterodyned to the 20-30 kHz range. This upper sideband is then mixed with a stable 19.000 kHz tone, and the lower sideband of 0.1 to 10 kHz selected. Thus a 1 kHz input would be changed to 20.805 kHz, then back to 1,005 Hz. Input and output are 600Ω; input and output levels are +4 VU; gain is unity; frequency response 50-10,000 Hz ± 5 dB; and s/n is 55 dB. *Mfgr: Audio Instrument Co. Price: \$575.00*  
*Circle 54 on Reader Service Card*

New Microphones



● Two new cardioid dynamics designed for entertainers, tape recording, and interview work are now in production. Designated models 650A and 651AH, these microphones feature an on/off switch than can be locked on. The 650A has a bass rolloff switch that operates from 400 Hz down. It also features 15/250 or 20,000Ω impedances with an output level of -56 dBm/10 dynes/cm<sup>2</sup>. Average front-to-back ratio is 20 dB. The 651AH is high impedance only, has a -57 dBm/10 dynes/cm<sup>2</sup> output with an average front-to-back discrimination of 15 dB. *Mfgr: Altec Lansing Price: 650A \$75.00 Net 651AH \$62.50 Net*  
*Circle 51 on Reader Service Card*

New Recorder Line

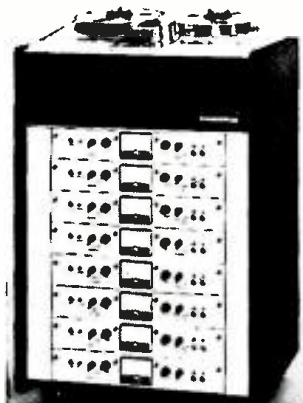

● The model 500A professional recorder is designed for broadcast studios, program automation, and educational institutes. Meeting all NAB requirements, it offers two-directional record-and-reproduce capability. All operation can be remote controlled. Separate high/low torque switches are provided for each reel drive motor. The capstan motor is two-speed and is available with any two adjacent speeds from 1 7/8 to 15 in/sec. Mono and stereo options for full-track, half-track, two-track, and four-track operation are available. There is also a single-speed logger model with 5 1/16, 1 5/32, or 1 5/16 in/sec. speeds. *Mfgr: Metrotech, Inc. Price: \$1695.00 (two-track stereo); Automatic Reverse Units are \$1895.00*  
*Circle 58 on Reader Service Card*



● The introduction of this line of audio equipment offers some new tools to the working professional. The plug-in type production modules each offer a complete system that can be installed or removed as easily as a vacuum tube.

The MX-101 is a mixing amplifier offering a gain of 40 dB; +10 dBm power; 20-20,000 Hz, ±0.5 dB response; distortion less than 0.5 t.h.d. at +10 dBm; noise -100 dBm. Power requirements are for 24 V d.c. at 15 mA. Connection from any standard low-impedance source is via a standard 11-pin male plug.

A universal power amplifier, the model PA-201, offers 5 watts into an 8-Ω load (1 watt into 50Ω). Distortion is typically 0.2 per cent t.h.d at maximum with loads higher than 8Ω. 28 volts is required for power at up to 3 amps (depending on load impedance and power output).

A regulator module, model PS 201, provides output voltages set at the factory at 24 V d.c. An internal control allows adjustment from 18-26 volts. Output current supplied is 0-300 mA. Load regulation is ±0.05 per cent. Line regulation is ±0.05 per cent, 105-125 V a.c. with any constant load from 0-300 mA. Noise and ripple is less than 5mV r.m.s.

A complete power supply, the model PS 301 converts 105-125 V a.c. into 28 V d.c. (adjustable internally from 24-30 volts) at a continuous current of 0-2 amps. Regulation is 1 per cent for 105-125 V a.c. Noise and ripple is below 20 mV peak-to-peak.

There is also a T0101A tone oscillator that can be supplied to provide any frequency between 20-20,000 Hz. High

output at 600Ω unbalanced or low output at 150Ω unbalanced are provided. Distortion is 0.2 per cent t.h.d. and power requirements are 18-30 V d.c. at 10 mA.

Finally, there is the UA101C utility amplifier module. This offers a nominal gain of 40 dB, power output rated to +10 dBm, noise of -120 dB, with wide bandwidth and low distortion in keeping with the other modules. Input impedance is 10,000Ω bridging input, unbalanced. The unit operates into resistive or transformer leads of 600Ω or more, unbalanced.

Full descriptive literature of these units is available from the manufacturer.

*Mfgr: Arbor System, Inc.*  
*Prices: MX101 \$36.00*  
*PA201 \$54.00*  
*PS201 \$50.00*  
*PS301 \$95.00*  
*TO101A \$50.00*  
*UA101C \$30.00*

*Circle 59 on Reader Service Card*

New Products Literature

● A new catalog of electronic and electrical supplies contains 256 pages and lists 600 product categories manufactured by 74 companies. The catalog features a MIL specs guide, a MIL/EIA standard resistance values table, and a page of miscellaneous quick-reference data. Full indexing by item name and manufacturer is included.

*Mfgr: Charleston Electrical Supply Co.*  
*Price: no charge.*  
*Write to Charleston at 312 MacCorkle Avenue, S. E., Charleston, West Va.*



# Classified

## EMPLOYMENT

**WANTED—REPRESENTATIVES.** Active, qualified representatives to cover advanced audio line. Submit organization resume, territory normally covered and other lines handled. **Fairchild Recording Equipment, 10-40 45th Avenue, Long Island City 1, New York**

**WANTED — ENGINEER, ELECTRONIC.** To participate in the design and development of circuitry for Ampli-Vox sound reinforcement systems. Knowledge of audio transducers desirable. Work in nationally recognized electro-acoustical laboratory. Benefits include hospitalization, major medical, profit sharing, tuition scholarship. **Perma-Power Co. 5740 N. Tripp, Chicago, Illinois 60646.**

**WANTED — AUDIO MAINTENANCE TECHNICIAN** to handle installation, repair, maintenance and some operation of quality audio equipment. Strong maintenance background mandatory. Send resume to **James Gundlach, State University College, Oneonta, New York 13802, or call 607, 431-3316**

## FOR SALE

**WESTREX 2B — Mono cutting system complete, A-1 condition, with RIAA equalizer, spare tubes, parts, and styli. \$1800.00 F.O.B., New York. Call 212 CH 2-1455**

**SCULLY TAPE RECORDERS — One to twelve track. Two, four, and eight track models in stock for immediate delivery. SCULLY LATHES — Previously owned and rebuilt. Variable or automatic pitch. Complete cutting systems with Westrex heads.**

**MIXING CONSOLES — Custom designed using Electrodyne, Fairchild and Universal Audio modules. From \$4000.00.**

**Wiegand Audio Laboratories, 221 Carton Avenue, Neptune, N.J. 07751, Phone: 201 775 5403**

**SOLID-STATE 50 WATT RMS plug-in d.c. thru 25 kc operational power amplifier kit, model 440K. Price \$30.00. Send for free catalog and 50 operational amplifier applications to: Opamp Labs. 172 So. Alta Vista Blvd., Los Angeles, California 90036.**

## SERVICES

**MASTERING AND REFERENCE COPY— Mono, Stereo — Top notch equipment — top engineering. Sön-Deane Records, Hartsdale, New York 10530. Telephone: 914 OW 3-1590**

## PROFESSIONAL DIRECTORY

**PHILIP C. ERHORN**  
Systems Design and Specifications  
Custom Consoles Technical Writing  
P.O. Box 861, Stony Brook, New York 11790. Tel: 516 941-9159

## EQUIPMENT WANTED

**HEWLETT PACKARD LOW FREQUENCY 'SCOPE model 120B or 130C or equivalent. Box A3, db Magazine, 980 Old Country Road, Plainview, N.Y. 11803**

**REK-O-KUT CVS 12 VARIABLE SPEED TURNTABLE in good condition. Box C3, db Magazine, 980 Old Country Road, Plainview, N.Y. 11803**

**PRESTO 800, 825, 850 recorder or deck. Giere, 212 661-4090. 200 W. 54th St., N.Y.C. 10019**

## AN ASTOUNDING NEW AUDIO NOISE REDUCTION SYSTEM WHICH IS MAKING BACKGROUND NOISE YESTERDAY'S PROBLEM.

The Dolby System gives

A 10dB increase in  
usable dynamic range

A 10-15dB hiss reduction

A 10dB print-through and  
cross-talk reduction

A 10dB hum reduction

**PLUS generally cleaner, more  
transparent recordings—with  
unaltered frequency response  
and signal dynamics.**

Recording engineers and musical directors are so enthusiastic about the Dolby S/N Stretcher system that the network of users is growing at an astonishing rate—on an international scale. Master tapes made with the system now fly regularly between the major recording centers of the world, such as New York, London, Rome, and Vienna.

The basic principle of the system is simple. Low-level signals are amplified in four independent frequency bands during recording and attenuated in a complementary way during playback—recording noises being reduced in the process. High-level signals are unaffected by this procedure (no distortion or overshooting), and the symmetrical design of the circuitry ensures that the signal is restored *exactly* in all details—high-level and low-level, amplitudes and phases. The result is a noise reduction system with ideal characteristics—perfect signal handling capability which can pass any line-in, line-out A-B test, and a genuine 10dB noise reduction.

In short, the Dolby system offers an entirely new area of sound for the recording engineer. Get to know more about it fast by writing directly to Dolby Laboratories or contacting your nearest agent.

## DOLBY LABORATORIES INC.

333 SIXTH AVENUE · NEW YORK · N.Y. 10014  
Telephone: (212) 243-2525 · Cables: Dolbylabs New York

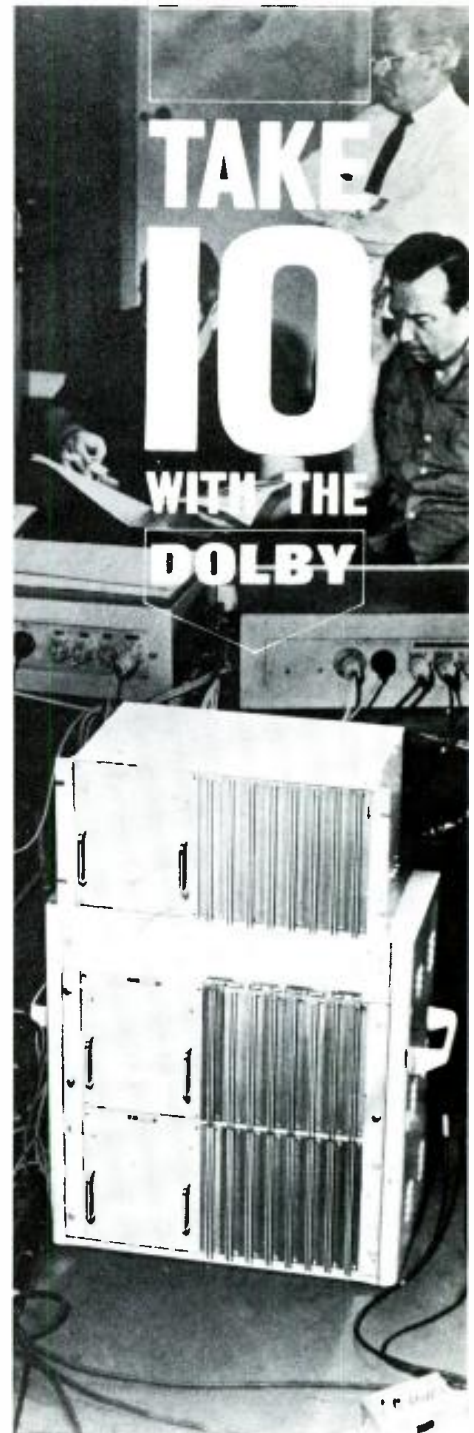

Circle 20 on Reader Service Card

# People, Places, Happenings

■ **Roger Czerniak** has been promoted to dealer and distributor sales manager of **Nortronics Company, Inc.** According to **John A. Yugve**, company president, his new assignment will include the administration of replacement head sales. Mr. Czerniak has been assistant sales manager in the dealer and distributor division for the past two-and-a-half years. Prior to his employment at Nortronics, he was associated with the **Bell and Howell Co.** in various sales assignments as well as the **Burroughs Corporation**, Duluth Branch.



■ **James H. Kogen** has been elected vice president of development and design engineering for **Shure Brothers**. He has also been named chairman of the Midwest Acoustic Conference just held at Northwestern University on April 11th. Mr. Kogen has served as chief engineer of r and d since joining Shure in 1962. He is a graduate of the Illinois Institute of Technology (1949) with a B.S. in electrical engineering. In 1956 he received his M.S. from Northwestern University in the same subject. He is a member of the IEEE, AES, and the Instrument Society of America.

■ **Brigham Young University**, has announced its **Second Annual Recording Seminar**, to be held the week of August 12-16, 1968. This seminar, held on the campus at Provo, Utah, high in the Rocky Mountains, will be similar to the one held last year. Subjects to be covered include professional recording techniques, acoustics, mixing, editing and special displays of equipment provided by manufacturers to the trade.

The seminar last year was conducted by such well-known personalities in the industry as **William L. Robinson**, Capitol Records, **John Neal**, ABC Television, **Dr. Earl Kent**, C. G. Conn, **Lou Burroughs**, Electro-Voice, **Don Eilers**, 3M, **Ed Dowling**, Ampex, **James B. Keysor**, Century Records, and **William G. Dilley**, Spectra Sonics.

Some of these same men, and others with similar qualifications, are being selected to direct the activities this year. For complete information write to:

Mr. Kaye L. Jensen, Promotion Chairman, Recording Seminar, Box 41, HFAC, Brigham Young University, Provo, Utah 84601.

■ A new motion-picture sound recording facility, **Film Sound, Inc.**, has been announced by its president, **Grant H. Gravitt**, as the largest and most completely equipped studio in the south. Film Sound is using the most advanced Magna Tech 16-35 mm film recording equipment, installed at a cost of more than \$100,000. The company will provide a complete range of sound services including scoring stages, mixing, transfers, foreign language dubbing, interlock screening, and related services — for both 16 and 35 mm.



■ **Paul Spranger** has been promoted to the position of chief engineer of electronics for **Altec Lansing**, a division of **LTV Ling Altec, Inc.** Mr. Spranger, who has had the title of senior engineer, joined the company a year ago. He has been active as an electronics engineer for eighteen years. Prior to joining Altec Lansing, he was director of r and d with a major manufacturer of electronic amplified musical instruments. Mr. Spranger has a BSEE degree from Pacific States University.

■ **DuKane Corporation** has purchased 36½ acres for a 250,000 square-foot plant in the new St. Charles industrial development of the Central Manufacturing District in Illinois. The announcement, made jointly by **J. McWilliams Stone, Jr.**, DuKane president, and **James F. Donovan**, managing trustee of the district, disclosed that a design study is under way for construction of a complex of office, laboratory, and manufacturing facilities for the electronics firm. According to Mr. Stone, the new and much larger plant has been made necessary by almost uninterrupted growth during the past seventeen years — and by a five-year forecast of substantial sales increases in the school, hospital, industrial, and architectural markets.



■ From **Jensen Manufacturing Division** of the **Muter Company** comes word of the appointment of **William H. Dean** as national sales manager, consumer products division. Mr. Dean's previous experience in the electronics industry includes manufacturing distribution, and being a representative. He was associated with **Alpha Wire** as western regional sales manager, and was national sales manager for **G. C. Electronics**.

■ **Albert Kahn**, president of **Electro-Voice, Inc.** announced his resignation effective April 1. He retains his seat on the board of the parent company, **Gulton Industries**. Mr. Kahn began his electro-acoustical career in 1927, when he started Radio Engineers in South Bend, Indiana. Initially concentrating on the repair of radios and the installation of sound systems, the company soon evolved into a microphone manufacturing facility. In 1934, Mr. Kahn developed an important advance in the microphone industry — a balanced-coil device within the microphone that effectively cancelled hum pickup. By the start of World War II, the fast growing company, having changed its name to Electro-Voice, was also building commercial loudspeakers and noise-cancelling mics. In 1945, E-V moved to Buchanan, Michigan and expanded its business into the high-fidelity field. When it was acquired by Gulton Industries of Metuchen, New Jersey in 1967, E-V's gross annual sales had approached \$20,000,000. Mr. Kahn's future plans include the organization of a manufacturing operation, non-competitive with Gulton, in the Appalachian area. One of the purposes of this operation will be to offer employment and training to workers who are not now employable.

# *AR-2a<sup>x</sup> speakers and AR<sup>INC.</sup> turntables are used as laboratory measurement standards—*

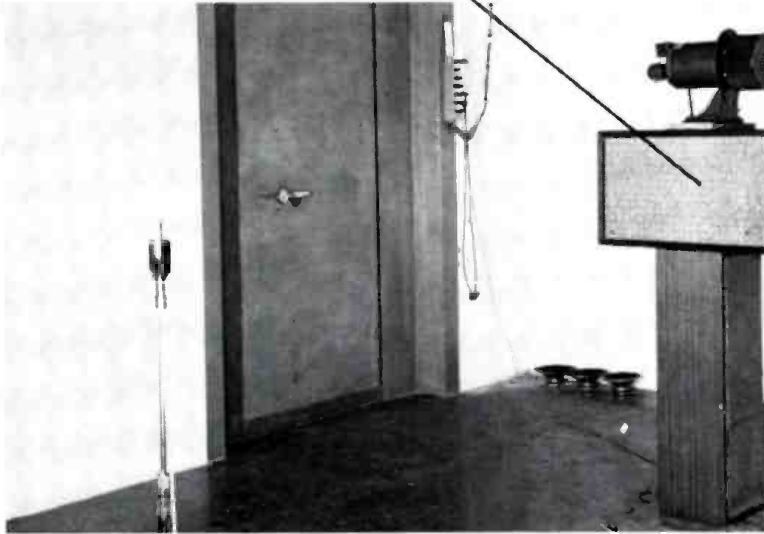

COURTESY PERMA-POWER CO.

Reverberant test chamber and associated laboratory test bench of the Perma-Power Company of Chicago, manufacturer of instrument amplifiers and sound-reinforcement systems. The AR-2a<sup>x</sup> speaker on the pedestal is used as a distortion standard to calibrate chamber characteristics. This test facility, described in a recent paper by Daniel Queen in the *Journal of the AES*, employs only laboratory-grade equipment. (Note the AR turntable on the test bench.)

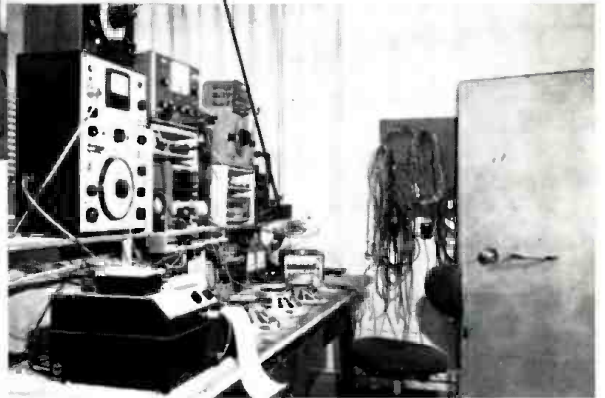

***but they  
were designed  
for music.***



COURTESY WABC-FM



Offices of the Vice President and General Manager, and of the Program Director of radio station WABC-FM in New York City. AR-2a<sup>x</sup> speakers and AR turntables are used throughout WABC's offices to monitor broadcasts and to check records. WABC executives must hear an accurate version of their broadcast signal; they cannot afford to use reproducing equipment that adds coloration of its own.

ACOUSTIC RESEARCH, INC., 24 Thorndike Street, Cambridge, Massachusetts 02141

*Circle 11 on Reader Service Card*

Anyone can build  
a column speaker.

We've built  
something better.

A new Line  
Radiator.

The LR4SA.

**(E)** Column speakers look simple. Do it yourself? Why not!

Just hammer up a long box, grab a handful of radio-set speakers and a few feet of wire, and hook them up. Now cover the face with a couple of yards of hi-fi grille cloth and you're done. And it may even work.

Of course it won't be perfect.

It will be very heavy.

It won't be weatherproof.

Its polar pattern will be irregular — high frequency output lobes may appear almost anywhere (with at least one off the ends or back, right where you need a quiet spot for a microphone).

And finally, it may sound like nothing more than a long, narrow table radio. Or worse.

The new LR4SA Line Radiator\* was designed to combat the many ills of hit-or-miss column speaker construction.

Start with the housing. We use a single channel of extruded aluminum, plus cast end caps. Very light. Weatherproof. Much stronger pound-for-pound than wood or steel. With no maintenance needed — indoors or out.

The grille is equally unusual. Acoustifoam<sup>®</sup>. We developed this foam plastic to be completely transparent to sound — yet act as a solid barrier to water!

And the LR4SA sounds better. You get solid coverage of a wide area with flat response. Unwanted lobes of energy at the backs and sides are sharply suppressed. It's quite a trick — and very useful to you.

It's accomplished in the LR4SA with very special 3" x 5" speakers, chosen for rising response, teamed with electrical filtering that progressively rolls off highs at the ends of the column. This "contouring" of the response of every speaker is the basic difference between column speakers and a Line Radiator.

The next time you face a job that calls for a column — try the LR4SA Line Radiator instead. It can make your day!

\*T.M.

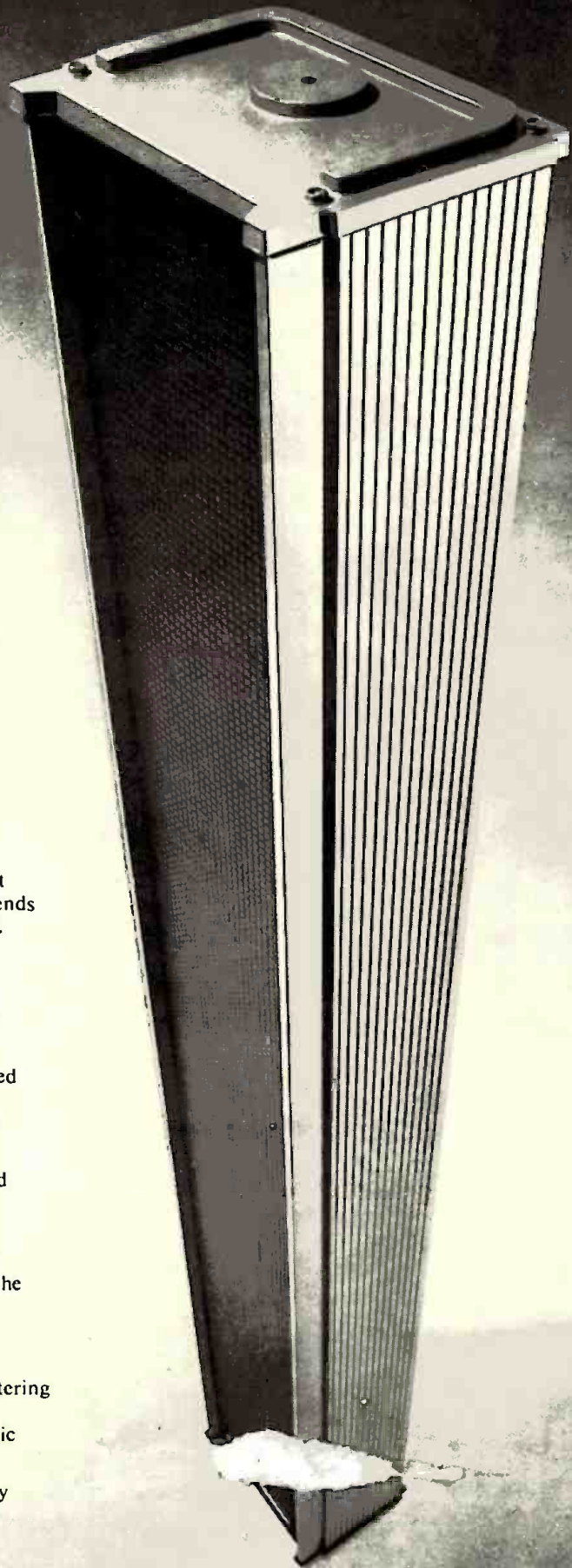

Specifications: Frequency Response 200 to 10,000 Hz; 80 Watts Peak Power; Dispersion 160° Horiz. 30° Vert.; Net Weight 25 lbs.; Size 48-3/8" L x 6-5/8" W x 4-7/8" D; \$150.00 List (less normal trade discounts).

high fidelity systems and speakers • tuners, amplifiers, receivers • public address loudspeakers  
microphones • phonograph needles and cartridges • organs • space and defense electronics

**Electro-Voice<sup>®</sup>**

Electro-Voice, Inc., Dept. 486BD, 686 Cecil Street, Buchanan, Michigan 49107

Circle 12 on Reader Service Card