

dlb

THE SOUND ENGINEERING MAGAZINE

OCTOBER 1972

\$1.00



CBS LABORATORIES

NTP

WARREN LABORATORIES

SPECTRA SONICS

EVENTIDE CLOCK WORKS

CUE MASTER

moog
MUSIC INC

Scully

DIGITAL DELAY LINE
OUTPUT I OUTPUT II
DOL 1745
EVENTIDE CLOCK WORKS

BROADCAST PRODUCTS
DYNAMIC NOISE FILTER

Lou Downing

CONTROLLERS
OSOL

9572225

4/24/74
4/24/74
4/24/74

CHIEF ENGINEER
WRBA
2301 W MAIN ST
RICHMOND IN 47374

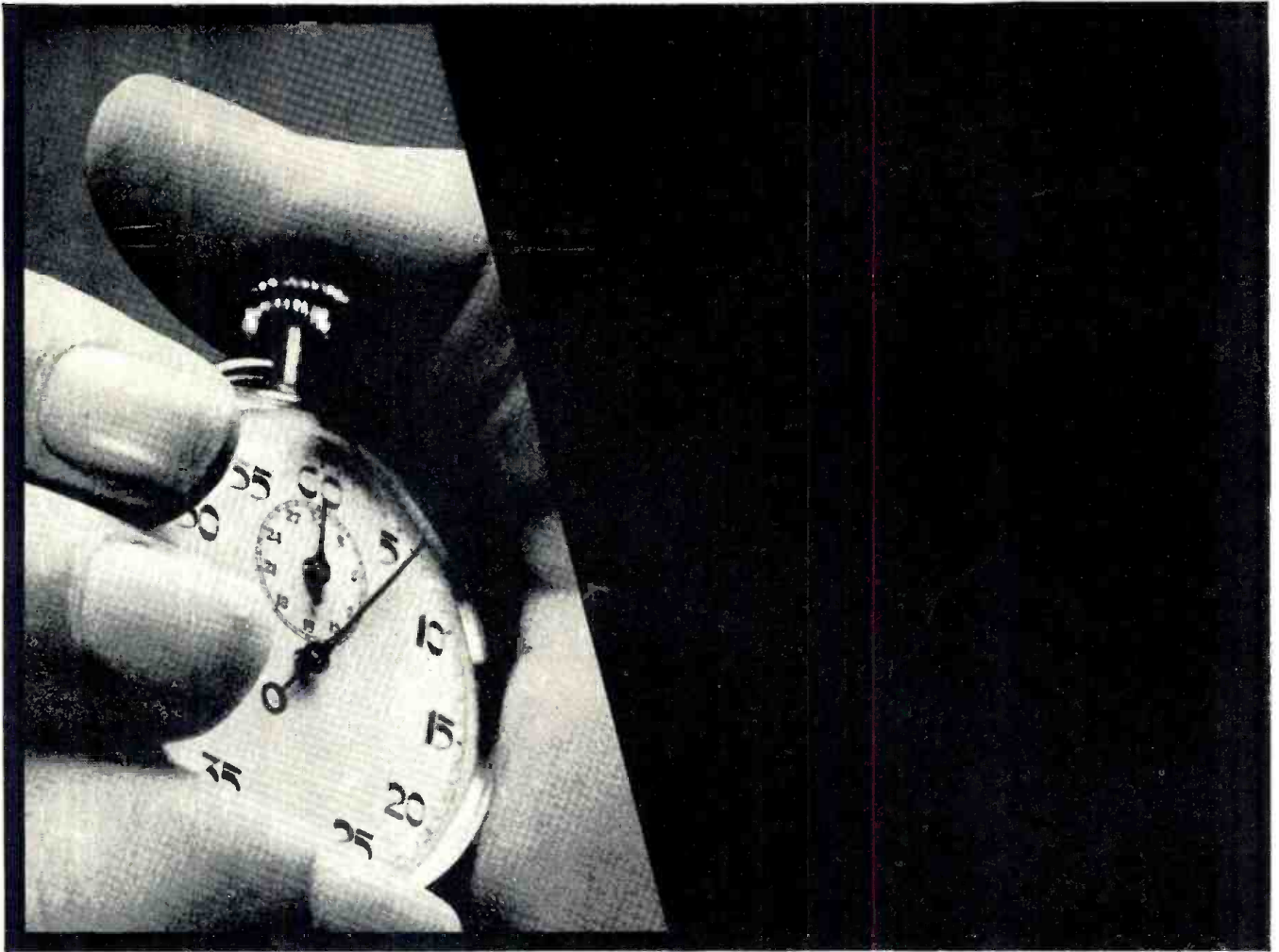

Solve 7 problems...in seconds.



Something totally new to add to your bag of tricks! We call them *Plug-in Problem Solvers*. They're designed to provide seven common modifications in microphone and sound system setups without soldering or rewiring—just plug them in! The Model A15A Microphone Attenuator that prevents input overload; Model A15PR balanced line Phase Reverser; and A15HP High Pass and A15LP Low Pass Filters to modify low and high frequency response; A15PR Presence Adapter to add brilliance; A15RS Response Shaper to filter sibilance and flatten response; and the A15LA Line Adapter that converts low impedance microphone inputs to line level inputs. Carry them on every job. It's a lot easier than carrying a studio console with you!

Shure Brothers Inc.,
222 Hartrey Ave., Evanston, Ill. 60204.



Circle 10 on Reader Service Card



THE SOUND ENGINEERING MAGAZINE

OCTOBER 1972 VOLUME 6, NUMBER 9

COMING NEXT MONTH

● John Woram abandons his usual column to write a feature article on his design (and use) of a switching system that permits the use of the same Dolby units for several machines of different track configurations. It's a true how-to-have-your-cake-and-eat-it-too story.

Walter Jung is back with his AUTOMATING THE AUDIO CONTROL FUNCTION. In part 4 you will discover a brand new kind of integrated circuit, the Harris Semiconductor PRAM and its application to audio switching systems.

Marshall King, our man about t.v. audio has written a provocative article with the title (ONE MAN'S OPINION) ON THE BUSINESS OF HEARING. We think you will find his comments important and worthy of serious consideration.

And there will be our regular columnists: George Alexandrovich, Norman H. Crowhurst, Martin Dickstein. Coming in **db**, **The Sound Engineering Magazine**.

- 17 NEW YORK AES CONVENTION—
PICTURE GALLERY
- 23 BUILD A DIGITAL READOUT ELECTRONIC
STOPWATCH
Ralph E. Hornberger
- 28 AUDIO VISUALS UNDER THE STARS
Martin Dickstein
- 34 APRS '72
Ham Brosious
- 2 THE AUDIO ENGINEER'S HANDBOOK
George Alexandrovich
- 8 THEORY AND PRACTICE
Norman H. Crowhurst
- 14 THE SYNC TRACK
John Woram
- 38 SOUND WITH IMAGES
Martin Dickstein
- 40 BOOKCASE
- 41 CLASSIFIED
- 42 PEOPLE, PLACES, HAPPENINGS

db is listed in **Current Contents: Engineering and Technology**,

Robert Bach PUBLISHER	Larry Zide EDITOR
Bob Laurie ART DIRECTOR	John Woram ASSOCIATE EDITOR
A. F. Gordon CIRCULATION MANAGER	Marilyn Gold COPY EDITOR
Eloise Beach ASST. CIRCULATION MGR.	Richard L. Lerner ASSISTANT EDITOR
GRAPHICS Crescent Art Service	

ABOUT THE COVER

● Ham Brosious who assembled our story on APRS '72, appearing on page 34, is seen in discussion with a typical (his word) English engineer. The booth is that of Feldon Audio Ltd., of London, England.

db, the Sound Engineering Magazine is published monthly by Sagamore Publishing Company, Inc. Entire contents copyright © 1972 by Sagamore Publishing Co., Inc., 980 Old Country Road, Plainview, L.I., N.Y. 11803. Telephone (516) 433 6530. db is published for those individuals and firms in professional audio-recording, broadcast, audio-visual, sound reinforcement, consultants, video recording, film sound, etc. Application should be made on the subscription form in the rear of each issue. Subscriptions are \$6.00 per year (\$7.00 per year outside U. S. Possessions, Canada, and Mexico) in U. S. funds. Single copies are \$1.00 each. Controlled Circulation postage paid at Harrisburg, Pa. 17105. Editorial, Publishing, and Sales Offices: 980 Old Country Road, Plainview, New York 11803. Postmaster: Form 3579 should be sent to above address.

George Alexandrovich

THE AUDIO ENGINEER'S HANDBOOK

Transients in audio systems

● Almost every system is either susceptible to some sort of transients or has elements capable of producing sudden current changes which can leak into the main audio channels. It is our desire to see that no transients exist in the audio systems. This can be easily accomplished in the systems which are mass produced, where wire dressing and component layout can be experimentally determined. However, as requirements change, more and more systems are being custom made, meaning that there are no experimental models. The first model is the final model—there is no time and no money allocated to experiment. The same unit has to perform, has to look good, and whoever builds it can not lose money on it. (I am referring to an audio manufacturing firm or contractor.)

This kind of the system has many switches, relays, and jacks—each one a potential source of transients. In engineering such a system, most engineers are guided by a standard set of rules which help to prevent transients, generally referred to as pops and clicks. Less experienced technicians sometimes allow mistakes to happen—which may cost more in time than one can afford. For instance, instead of running separate wires for the relay circuits and amplifier circuits, he may end in rewiring the whole console. In the best case, a “fix” would have to be used in every control and amplifier circuit to subdue pops and clicks to a tolerable level. And the big question is what is *tolerable*?

On one occasion, in order to guide ourselves in specifying and testing audio systems we called the Federal Communications Commission, the NAB, IEEE, and AES. Our question—what are the standards for transients in communications?, what are the limits—and do you have any suggested measuring techniques? These were left unanswered. There are no standards concerning transients. For instance the FCC told us that transients should be below audibility at normal listening levels. What are *normal* listening levels. One level is acceptable in a broadcasting studio

where the monitor amplifier may be a 15 watt unit, while in the recording studio there may be several 100-watt amplifiers producing sound pressure levels beyond safe levels for human hearing.

Specifying transients by referring the transient levels to the noise levels is also vague. Some systems have noise level only few dB above the theoretical minimum, while others may be 10-20 dB higher.

Transients can be tricky. Some may have very steep fronts and fast decays, others may have gentle fronts with slow decays. If we display them on the scope, some will appear as sharp spikes, others just as a change of base line position. Sharp transients usually have very high voltage peaks but very little power. Others may have very low voltage peaks, but a lot of power. The amount of power contained in the transient is equal to the area contained by the waveform

advertisers index

Acoustic Research	3
Altec	7
Audio Distributors	33
Auditronics	37
Automated Processes	26, 27
BHK Electronics	12
Duncan Electronics	Cover 4
Electro-Voice	4
Fairchild Sound	19, 20
Gately Electronics	22
Gotham Audio	15
ITI	16
Neve	35
Quad-Eight	30, 31
Sansui	9, 10, 11
Shure	Cover 2
Soundcraftsmen	12
Spectra Sonics	5
Telex	6
Timekeeper	Cover 3
UREI	13
Windjammer	21

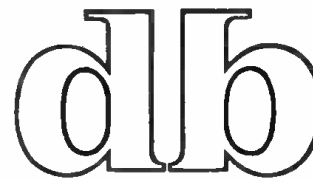

THE SOUND ENGINEERING MAGAZINE

SALES OFFICES

New York
980 Old Country Road
Plainview, N.Y. 11803
516-433-6530

Dallas
Roy McDonald Associates, Inc.
Semmons Tower West
Suite 714
Dallas, Texas 75207
214-637-2444

Denver
Roy McDonald Associates, Inc.
846 Lincoln Street
Denver, Colorado 80203
303-825-3325

Houston
Roy McDonald Associates, Inc.
3130 Southwest Freeway
Houston, Texas 77006
713-529-6711

Los Angeles
Roy McDonald Associates, Inc.
1313 West 8th Street
Los Angeles, California 90018
213-483-1304

Portland
Roy McDonald Associates, Inc.
2305 S. W. 58th Avenue
Portland, Oregon 97221
503-292-8521

San Francisco
Roy McDonald Associates, Inc.
625 Market Street
San Francisco, California 94105
415-397-5377

The AR Laboratory Standard Transducer

**A speaker for professional use
from Acoustic Research**

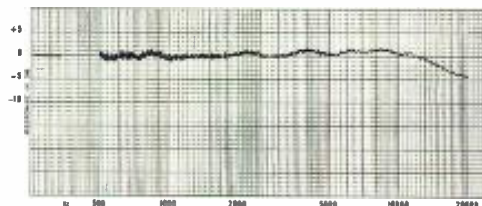
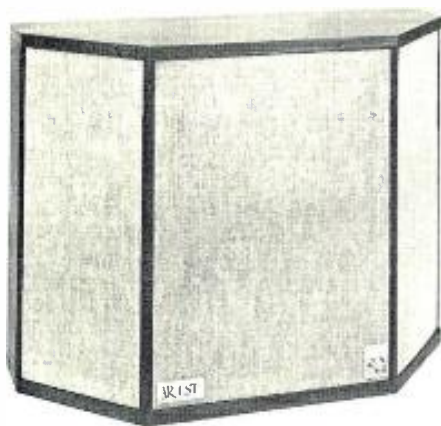

ACCURACY AND FLEXIBILITY: The AR-LST offers a total of six different energy profiles — all accurately known and repeatable at the turn of a switch, which is located on the front of the cabinet. This permits a degree of control and precision that is usually found only in electronic equipment.

FLAT ENERGY CAPABILITY: The AR-LST is capable of a flat energy output characteristic that, in our judgement, establishes a new state of the art. The graph shown above represents the acoustic power output produced by the AR-LST with its control set to the “flat” position. The horizontal line below 500 Hz indicates the relative woofer level.

LOW DISTORTION: As with the AR-3a, harmonic distortion measurements down to the lowest audible frequencies are, to the best of our knowledge, the lowest of any loudspeaker system available.

WIDE DISPERSION: AR's hemispherical dome tweeters produce exceptionally smooth, wide dispersion of midrange and high frequencies, even in rooms or studios that are acoustically rather dead.

POWER HANDLING: Multiple drivers for midrange and high frequencies enable the AR-LST to handle power levels significantly higher than AR's finest speakers designed primarily for home use.

Detailed information on the AR-LST is available on request. Mail the coupon below.



Acoustic Research, Inc.

24 Thorndike Street
Cambridge, Massachusetts 02141, Dept. DB-10

Please send the booklet describing the AR-LST to

NAME _____

ADDRESS _____

One of a series of brief discussions
by Electro-Voice engineers

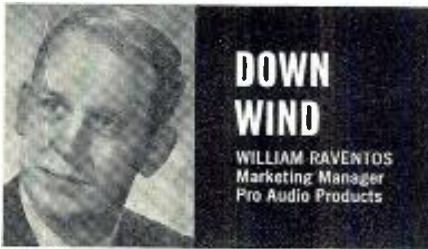

Several years ago, Electro-Voice introduced a windscreens material for microphones we call Acoustifoam that offered a substantial improvement over the bulky silk and wire constructions then in use.

Recently a number of windscreens similar in appearance to Acoustifoam have arrived on the market. But not all plastic windscreens are alike. A number of characteristics of foam plastic can strongly influence the effectiveness of the material as a windscreens and the performance of the microphone hidden inside.

The material used in Acoustifoam is carefully controlled for density and porosity, and goes through a number of extra processing steps required to meet the standards set for it. In addition to reducing the sounds of air turbulence near the microphone (thus serving as an effective windscreens) it must have no appreciable effect on microphone frequency response, level, or polar response at any frequency.

The passive nature of this material is assured by the extra processing of the basic foam after it is molded. Look closely at most ordinary foam (and even some foam sold as windscreens material) and you will see bright highlights from tiny flat surfaces that cover many of the pores in the foam. Each closed pore in the foam acts as a reflector of sound, and as a barrier, and will significantly alter microphone response and even output level in extreme cases. High frequency roll off of up to 20 db at 10 kHz has been measured with some foams.

The method used to "open up" these closed pores is called reticulation, and is a chemical treatment that dissolves the very thin pore walls without substantially altering the heavier foam connecting material. Another test for foam is to blow gently through the material. If any resistance is felt, the foam is insufficiently porous for windscreens use.

Pore size (after reticulation) is also a significant part of windscreens design and can have an effect on the ability of a windscreens to satisfactorily reduce wind noises to the lowest possible value. Thickness of the windscreens itself also has an important bearing on its wind noise reduction capability. Foam of insufficient thickness will prove less effective in controlling wind noise.

While windscreens may seem simple and uncomplicated devices, in truth their design must match the sophistication of the microphone inside if full benefit is to be obtained from both microphone and windscreens.

For reprints of other discussions in this series,
or technical data on any E-V product, write:
ELECTRO-VOICE, INC., Dept. 1023BD
686 Cecil St., Buchanan, Michigan 49107



and the baseline .

Modern technology—using directly-coupled amplifier circuits and operational amplifiers capable of amplifying signals from d.c. to MHz range create conditions where transients are harder to subdue and isolate. But at the same time we have better and cheaper tools to control it. We can afford to put a regulator at each amplifier and still not go broke.

But before we go into remedies let us review the causes of transients.

1. Turning on the power supply creates a d.c. wave front until all amplifiers stabilize and all capacitors get charged.
2. Changing power consumption by turning on tally lights, turning on additional amplifiers or circuits.
3. Turning on or off relays or other inductive circuits.
4. Changing the load on the amplifier output or input.

The first condition depends greatly on the construction of the power supply and the amplifiers. If the design is such that d.c. rises slowly and each amplifier has each own decoupling circuit—damping and smoothing this wavefront—then a transient will not be detectable.

The second condition exists in almost any system and is hardest to control. One of the surest ways to control it is to use a separate power supply system for control and light circuits from amplifier or audio lines. If you are forced to use the same power supply then it should have low source impedance and separate lines should originate from the output terminals of the power supply. If the amplifiers have good decoupling, chances are you may supply all circuits from the same line without creating transients. Electrolytic capacitors in decoupling networks may have enough capacity to store enough charge to keep the amplifier voltage constant while the supply line voltage changes up or down. Voltage regulators on each amplifier can assure complete isolation of the amplifier from the transient carrying the supply line. The only way for such an amplifier to sense and amplify a transient would be if inductive or capacitive coupling exists between the parts of the amplifier and the supply line.

The third condition happens when relays or inductive circuits are turned on or off. It is the hardest one to combat because most of the time relays carry audio, and the proximity of the relay coil to the audio lines creates inductive coupling which is hard to isolate. We all know that at the instant when the relay coil is connected to the power line its impedance is very high as long as the cur-

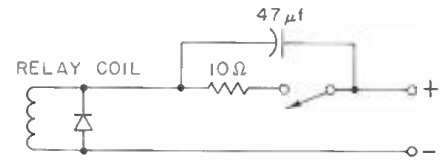

Figure 1. This is the best method to reduce the sharp spike an inductor creates.

rent increases. As soon as the current achieves its maximum value impedance drops to the value of the d.c. resistance. Opening of the d.c. circuit creates a sudden change in the supply current in the power line—but the coil experiences a sudden change in magnetic flux which creates very high voltage across the winding. The theory of this phenomenon is complicated and is not worth analyzing now. However, we should know that this so-called back EMF (electro-motive force) created by the opening of the electric circuit containing inductor has to be eliminated.

This is accomplished by connecting a diode across the inductor. This diode is connected so that the supply voltage reverse biases it. Back EMF is opposite in polarity to the supply voltage and the diode conducts these currents, creating the short between the coil and the diode.

But a diode is not always enough to reduce the sharp spike an inductor creates. Many may suggest a combination of diode and capacitor, but a capacitor only creates a tank circuit capable of resonating at certain frequency—and at the time current is disconnected from the coil, dying oscillations set in. This effect may be more harmful than just one fast spike.

My method as shown in FIGURE 1 is not new, but not many use it the same way. It consists of using a resistor and capacitor at the switch, turning the circuit on and off. Connecting the 10-ohm resistor in series with the switch and the capacitor across both the resistor and the switch provides a gentle current change when turning the circuit on and off, and reduces the transient peak manyfold. Values of the capacitor and the resistor may vary with different inductors but the principle works just the same. This method is only as good as engineering on the rest of the system. It goes without saying that if (with this noise suppression circuit) one connects the amplifier into the ground side (or negative) of the circuit—both have same common ground—then all efforts may end up in vain. Also it should be noted that each switch should have its own suppression circuit. If there are 100 relays and 100 switches there should be 100 suppression circuits.

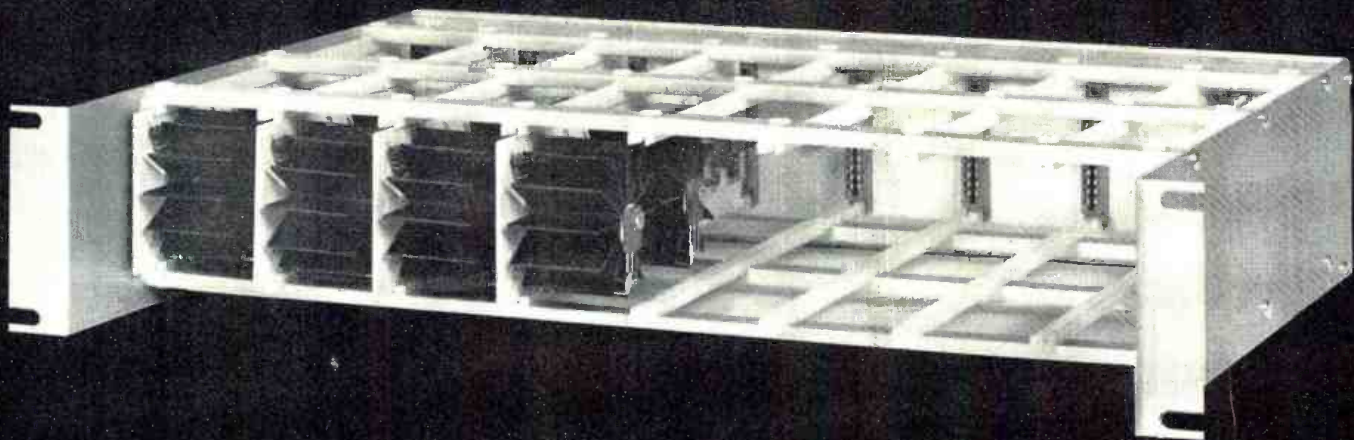

OVER 1000 WATTS

Pictured above is the new SPECTRA SONICS Model 202PC Card Holder. Wired as a four way system, the available power to the loud speakers will be greater than 1000 watts. With this flexible installation system, design is limited only to your imagination.

SPECTRA SONICS now provides the world's first and only multi-purpose power system. This outstanding unit is capable of bi-amplified 2 way speaker systems, tri-amplified 3 way speaker systems, hi-intensity 4 way speaker systems, or any number of multiple speaker systems.

SPECTRA SONICS utilizes the Model 505 Electronic Filter before amplification. Additionally the Model 700 Power Amplifier is used in a bridge (push-pull) configuration. This amplifier system increases the available average power output approximately 3 times that of conventional methods used in the past. Some of the numerous improvements of this new system are listed:

Lower Amplifier Distortion
 Less Physical Space Required
 (3-1/2" x 19")
 Reduced Amplifier Cost Per Watt

Greater Signal-To-Noise Ratio
 Increased Power to Voice Coil
 Easier System Installation
 Greater Expansion Capability

The SPECTRA SONICS Model 700 Power Amplifier is . . . **Beyond the State of the Art**

Continuous Power Output	60 watts RMS delivered to a load.
Bridged Configuration	(120 watts RMS with 2 amplifiers.)
Power Response	Within $\pm .1$ dB, DC to 20 kHz into 8 ohms at full output.
Total Harmonic Distortion	Unmeasurable – less than 1/100th of 1% DC to 20 kHz at full output.
Signal-To-Noise	Better than 100dB below 30 watts unweighted, 20 Hz to 20 kHz, typically better than 120dB.

To obtain additional information contact SPECTRA SONICS at:

770 Wall Avenue
 Ogden, Utah 84404

6430 Sunset Blvd., Suite 1117
 Hollywood, California 90028

SPECTRA SONICS

LEADER IN ADVANCED TECHNOLOGY



Circle 16 on Reader Service Card



Audiometric-type transducers make our headphones better. Better than any headphone you've ever tried. You can hear the difference; clear, live, distortion-free sound. But even more important, performance and sound are the *same*, all day, every day. Because our audiometric-type elements are absolutely stable to give you consistent performance at all times.

Originally, we developed audiometric elements for clinical hearing tests and measurements. This required elements that remain totally stable even with changes in temperature or humidity. Sensitive elements that respond efficiently to variances in frequencies and power input. Elements capable of sound reproduction at over 130 dB sound pressure level with very low distortion and without burning up.

Now we've modified and adapted this audiometric transducer element to give you a series of thoroughly professional headphones. Headphones you can rely on for stable performance — day in, day out. Clear and undistorted so you can truly monitor sound quality and balance and not just signal presence.

We make two series of professional models to meet your needs Series 1325 for stereo monitoring and series 1320 for communications, with optional noise cancelling boom microphone. Try our better hear muffs at better dealers — or write for free information. You'll hear more from Telex. ©

PRODUCTS OF SOUND RESEARCH
TELEX[®]
COMMUNICATIONS DIVISION

9600 ALDRICH AVENUE SOUTH • MINNEAPOLIS, MINNESOTA 55420

CANADA: DOUBLE DIAMOND ELECTRONICS, LTD., Ontario
EUROPE: ROYAL SOUND COMPANY, INC.,
409 North Main Street, Freeport, N.Y. 11520 U.S.A.

Circle 15 on Reader Service Card

Condition four deals with the changing of the amplifier load. Most amplifiers today are class AB amplifiers. This means that the amplifier draws only as much current as the load requires. If there is no load then the current remains the same. A small idling current is present all the time. The difference between class B and class AB is that there is no idling current in the class B amplifier but it has more crossover distortion than class AB. A class A amplifier always draws the full amount of current required for full output and is therefore very inefficient. If one watt of power is required from the amplifier (30 dBm) there will be over two watts of power dissipated in heat in the amplifier at all times, even when no signal is fed or amplified.

But getting back to the class AB amplifiers, if we connect loads to the output of the amplifier then we change the power consumption. At the instant we connect the load we create the transient. Some circuits have a capacitor to decouple the d.c. of the amplifier from the load. If there is no load connected, this capacitor has no charge. At the time the load is connected the capacitor charges, because there is a difference of potential between the load and the output of the amplifier. A transient is created by the additional current requirement and presence of d.c. on the output of the capacitor. This d.c. appears across the load for a short duration but is sufficient to produce a click or pop. Again, decoupling of the amplifier from the power supply is the answer for the power supply section—and a large resistor at least ten times the resistance of the load permanently connected across the amplifier output just to keep the capacitor charged at all times.

What I have just reviewed is not new and is well known to a good number of readers. But some of you may find it helpful in constructing your own systems. This subject revived my interest because of the fact that I could not find any specifications nor standards concerning allowable amount of transients and how they should be measured and classified. I was truly disappointed to learn that in this age of computer-controlled systems—where most of the electrical functions are switching functions—there is no better criterion for defining the allowable amount of transient than just judging it by ear. I sincerely hope that in the nearest future the brains of the audio engineering community will take up the subject of writing the set of standards which could guide us all in evaluating quality of our systems. ■

New Tools for Professional Monitoring



THE 8050A REAL TIME ANALYZER provides continuous audio spectrum scanning every 30 ms, 40 Hz to 16 kHz on ISO center frequencies. Has *fast* RMS response for visual program monitoring and *slow* RMS response for room equalization. Cost is about 1/3 of competitive models.

THE 9860A ACTIVE EQUALIZER has phase and amplitude transfer characteristics identical with those of the Altec passive equalizer. Permits detailed equalization from 40 Hz to 12.5 kHz. High and low-pass functions, 18 dB/octave, permit more precise finishing of frequency extremes. Cost is about 1/2 of comparable passive devices.

THE 8080A PINK NOISE GENERATOR plugs into standard Altec mixers. An ideal flat and stable noise source for room/speaker equalization with 24V power supply or battery. Cost is about 1/5 of standard noise generators.

THE 771B BIAMPLIFIER has a switchable 12 dB/octave crossover at 500, 800, and 1500 Hz. Can be adapted to most studio monitoring systems and coaxial speakers. Acoustical balances can be exactly controlled by separate HF and LF gain controls. The LF section delivers 60 Watts and the HF section 30 Watts continuous sine wave power.

For more detailed data and specs write Altec, Professional Studio Products, 1515 S. Manchester Ave., Anaheim, Calif. 92803.

ALTEC

Circle 17 on Reader Service Card

THEORY AND PRACTICE

● The month before last, this column discussed the different ways that signals can be viewed, a little: as a composite of audio frequencies, or as a wiggling waveform. There is another connection in which this has relevance. In that discussion we addressed particularly peak level aspects—how difference in shape affects clipping. But it also affects the other end of the dynamic range.

Before Dolby, there was a way of contracting and expanding dynamic range, to accommodate media that does not have the full range we would like, that used a compressor at one end and an expander at the other. This was a natural follow-on from the AVC, later called AGC (that's automatic volume control, and automatic gain control, in case you are unfamiliar with those terms), which worked on radio frequency (or i.f.) amplifiers, to adjust "front end" gain, so the signal at the detector had a common level.

Such devices used variable-mu tubes, which had a long grid base, so their gain could be varied by applying an adjustable grid bias. As we said, later the same variable mu tubes were used to adjust audio amplifier gain to provide compression and expansion.

Control for such automatic action was taken by rectifying audio signal and using it as bias for the variable gain stages. First came the compressor, that reduced the dynamic range of signal. If input signal range was 60 dB, from quietest to loudest, the compressor would provide 20 dB variation in gain in such a way as to reduce dynamic range to only 40 dB. After the signal was retrieved from the record or transmission with the limited range, an expander could again provide 20 dB variation in gain in such a way as to restore the full 60 dB range again (FIGURE 1).

With proper attention to the time constants by which the gain was changed, which had to be fast when a higher level signal came along, with a slow turn down to lower level, when there were no high peaks, the effect

of these components was quite spectacular, for that time. The relatively high background noise of the record or radio transmission virtually disappeared, as if by magic.

That was a first impression. But in those days we thought an acceptable distortion level was 5 per cent second, with equivalent of anything else that came with it. Experiments were even conducted in those days that showed that reducing distortion below 5 per cent could not be detected by the human ear. Sounds crazy, these days, doesn't it?

What that really illustrates is that what we measure is always relative. Would you try to measure the precision with which an automobile piston is made—which should be measured in ten thousandths of an inch, with the kind of 12-inch foot rule they issue to students in school? Of course not. You'd need a precision micrometer for a job like that.

There's no denying that the distortion meters could reliably measure down to 5 per cent and possibly as low as 1 per cent. But they were measuring audio signals in amplifiers, not acoustic waves coming from loudspeakers or headphones of the era, which produced well in excess of 5 per cent. With the listening devices producing well over 5 per cent, it was small wonder that we could not hear an extra something less than 5 per cent produced by the amplifier.

But those things have changed. And as better listening devices made it possible to hear less than 5 per cent distortion quite easily, we improved the standards we set for amplifier performance. And as we did this, we found that the wondrous things done

for dynamic range by compressors and expanders left something to be desired in the distortion department.

It was not difficult to find out why. High-level signals used a greater proportion of the tube's curvature, needed to make gain variable, so that it was virtually impossible to get much better than 5 per cent distortion when the control was providing maximum compression. This was compounded at the expander end.

A sustained high note would produce even more distortion, because every cycle of the wave would produce a little bit of bias change, to hold the gain down at the compressor and up at the expander, which would reflect as a spurious component on the waveform. There were other spurious effects such as the "breathing" that occurred, due to the variable gain at both ends altering the noise amplified from the middle. A steady, audible noise was preferable to one that breathed! One learned to ignore the steady noise, but obscene phone callers know how unsettling breathing can be!

Also, the effectiveness in reducing apparent noise level depended somewhat on program content—whether the noise showed up against it. Softly-playing bass instruments have little in the extreme highs, so hiss is particularly noticeable when this is the kind of program. If the compressor had a way of turning up the highs—even more than normal pre-emphasis—and having the expander turn them down again, so the over-all response was not changed, that hiss could be removed.

But to make that change in the amplifiers, when orchestral brass comes on—ouch! Everything blasts its head off. Then the highs need to go back where they belong.

One more thing. With the compressor/expander combination, the control signal was the same for each, which in one sense was ideal. It was from the output of the compressor and the input of the expander, where the dynamic range is reduced and the same.

For the compressor this is not bad. But for the expander, any change in level within the part with restricted (40 dB) range will produce exaggerated change in level at the output.

Fig. 1. The basic configuration of the compressor/expander system of accommodating links in a system having restricted dynamic range.

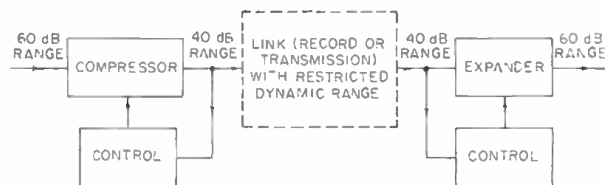



presents
the

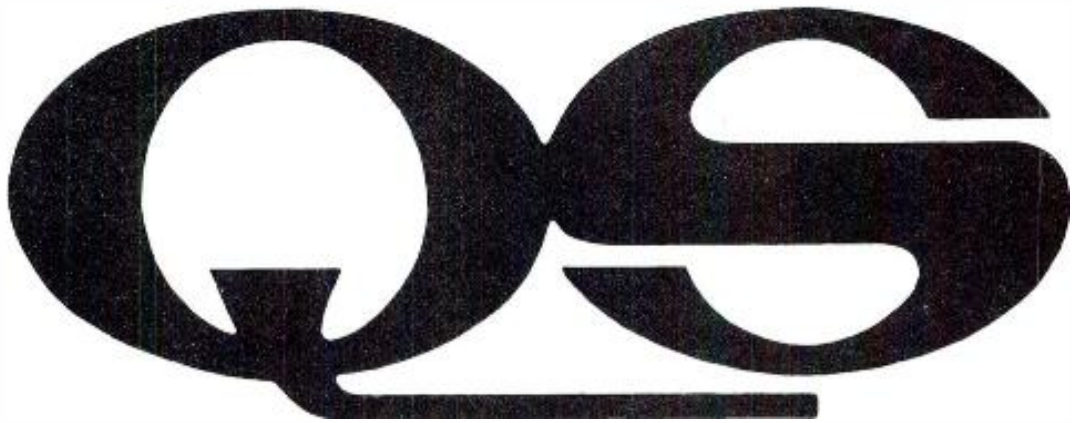

REGULAR MATRIX

professional four-channel
encoder/decoder

Believe *4-channel* *like*

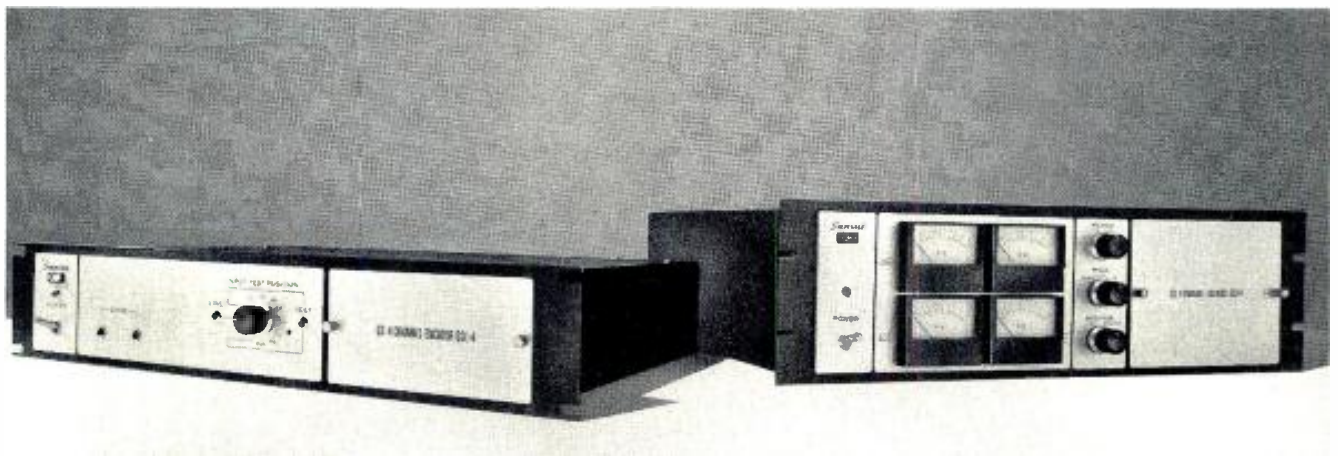

THE PAIR PAR EXCELLENCE

THE SANSUI QSE-4 ENCODER

THE SANSUI QSD-4 DECODER

It took a large investment in effort, time and money, a great deal of experimentation and devotion, of testing and ingenuity. But it's here now: the QSE-4 Encoder and its complementary QSD-4 Decoder are ready for your ears. Are your ears ready for them? Are you prepared to make A-B comparisons between a discrete four-channel original and the QS-encoded and decoded version of the same material—*without being able to tell the difference?*

Sansui's QS Regular Matrix System, from the beginning, was the only matrix that could accurately pick up and reproduce sound from any direction of the sound field and at any point within the sound field, including dead center, in the same way that could be done with a discrete source. It fell short only in not being able to offer optimum separation.

Today, with the exclusive j-shift technique and all the other original technology of the symmetrical system faithfully retained, the addition of the totally new Vario-Matrix technique now provides that separation. Full four-channel separation. The complete psychoacoustic effect, to match any other four-channel medium. With none of the complication or obsolescence inherent in so many other systems.

Tool up with the new QSE-4 Encoder and QSD-4 Decoder. If you want to get started in four-channel recording, why not start at the top?

your ears. finally sounds 4-channel.

Advantages of the Sansui QS Coding System:

- 1 THE QS SYSTEM** prevents directional error or the loss of any information in the encoding process. It therefore places no limitations on the right of the recording or broadcast engineer to experiment freely with new studio placement of performers.
- 2 THE QS SYSTEM** is the only matrix system that permits, at the decoding end, reproduction of sound anywhere in a full circle and at the dead center of the sound field. There are no weak locations in this completely symmetrical system.
- 3 THE QS SYSTEM** does not in any way degrade any current standards of high-fidelity sound reproduction, whether they involve noise, distortion, dynamic range, frequency response or anything else.
- 4 THE QS SYSTEM** offers dual compatibility with existing two-channel stereo equipment. On the one hand, when an encoded recording or program is played back on standard two-channel stereo equipment, the depth and dimension of the normal stereo presentation are enhanced. This makes it possible to produce a single version of any recording—one disc serves as both the four-channel and enhanced two-channel version. On the other hand, when a standard two-channel disc or other source is played through the decoder, a superb four-channel effect is synthesized.
- 5 THE QS SYSTEM** avoids the use of a high-frequency subcarrier. Resultant encoded material can thus be reproduced effectively even by a simple speaker matrix. The system is therefore easily and economically popularized.
- 6 THE QS SYSTEM** is a complete, all-purpose, all-media encode/decode process, with total compatibility with all equipment and standards. That applies to disc recording and broadcasting. Even to tape recording.

For full details on obtaining the new Encoder/Decoder or more background literature, contact your nearest Sansui office.



*For full details,
contact your nearest Sansui office now.*

SANSUI ELECTRONICS CORP.

Sansui Electronics Corp.

New York

55-11 Queens Blvd., Woodside, N.Y. 11377. Tel.: (212) 779-5300. Cable: SANSUIECNEWYORK

Telax: 422633 SEC UI.

Sansui Electric Co., Ltd.

Los Angeles
Tokyo

333 West Alondra Blvd. Gardena, Calif. 90247. Tel.: (213) 532-7670.

14-1, 2-chome, Izumi Suginami-ku, Tokyo 168, Japan. Tel.: (03) 323-1111. Cable: SANSUIELEC.

Telax: 232-2076.

Sansui Audio Europe S.A.

Belgium

Diaceem Building Vestingstreet 53-55, 2000 Antwerp. Tel.: 315663-5. Cable: SANSUIEURO ANTWERP.

Telax: ANTWERP 33538

Germany, W.

6 Frankfurt am Main, Reuterweg 93. Tel.: 33538.

WOW!

model F-2 flutter meter

- No discriminator or set level adjustments
- Wide carrier range
- Static drift measurement
- Precise, .01% internal oscillator
- Measures per IECF standard 193 1971



IF YOU ARE USING TAPE, DISC, OR MAG FILM EQUIPMENT, THINK ABOUT OUR FLUTTER METER. FAST, ACCURATE, & EXTREMELY STABLE. AND THINK ABOUT THE PRICE, TOO.

\$395.00

BHK Electronics, 3321 Hamner Avenue
Santa Barbara, Ca. 93110 (805) 967-3182

Circle 23 on Reader Service Card

Fig. 2. How the Dolby noise reduction system compares with the old compressor/expander system.

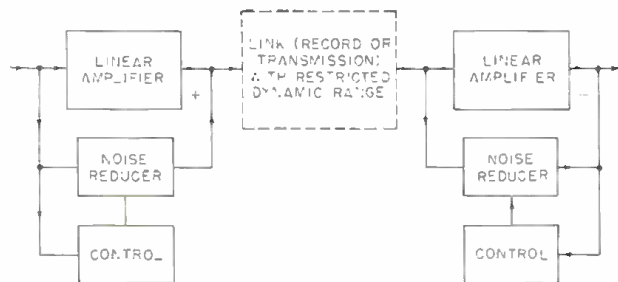

What Dolby apparently noticed in all this was that compressors and expanders essentially operate on the high level signal. Essentially they lowered the head-room, rather than raising the floor. While in some respects they are similar—either way the vertical space is reduced—they are not the same. What is really needed is a device that will pull the low-level signal above the noise, in the restricted height zone, and put it back down again at the other end.

This he does by making the main system operate on high level signal. Then he applies a noise-reduction system that gives low-level signals a boost at the sending end, and drops them back down again at the receiving end (FIGURE 2). Why is this so

much better than compressors and expanders?

In the first place, only linear amplifiers handle the full signal level. They have no variable gain elements. The noise reduction system handles only the low level signals, turning the gain up as the signal gets smaller, just as the radio AGC system does. And it does this at both ends.

The compressor turned the gain down as levels went up, and conversely, turned gain up as level went down so, in a sense, it works the same way as Dolby's noise reduction. The difference is that the compressor has the variable gain stages handle the whole signal, where the Dolby system has the variable gain elements handle only the low-level stuff. And at the receiving end, the action is opposite.

The expander turns gain up as level goes up. In the Dolby system, the main amplifier does not change. The noise reducer still turns gain up as level goes down, but uses it as negative feedback, to turn down the total low-level signal, and with it any noise picked up in the middle part where dynamic range is restricted. So it is, in the truest sense, a noise reducer.

That is not all. The compressor and expander was a high level puller down and pusher up. It worked on big signals. The noise reducer works on small signals. So when there is absence of signal in the highs or lows, it can work harder there than elsewhere. This is achieved by having the noise reducer work in frequency bands at both ends. (FIGURE 3).

Suppose now that the program is predominantly sweet and low. But what little highs there are should come through clean. So the highs at the sending end are boosted more than the lows. Then at the receiving end, a correspondingly bigger piece of highs are fed back, to restore the correct frequency response and balance. The hiss is turned down much more, because no program highs are present, without losing what program highs there are.

The same goes for the other end, to minimize rumble and low-frequency noise sources, which always seem worse when the program has nothing in those frequencies.

Soundcraftsmen presents the new **RP10-12**
PROFESSIONAL EQUALIZER for RECORDING and PLAYBACK
PERFECT tailoring of octave-wide bands... Infinitely variable adjustment flexibility
Special Effects programming ... Instant re-setting ... **\$349.50** includes walnut grain cabinet, or rack-mount

**Recording Studios • Audiophiles • Night Clubs • Performers • Theatres
Churches • Gyms • Auditoriums • Hi-Speed Duplicating • Musical Groups**

SPECIFICATIONS
FREQUENCY RESPONSE: $\pm 1/2$ dB from 20-20,000 Hz, 1dB down @ 10Hz, 1dB down @ 100 KHz.
HARMONIC DISTORTION: Less than .08% @ 2V, .05% @ 1V; Typ. 0.1% @ 1V.
SIGNAL TO-NOISE RATIO: Better than 90 dB below 2V output; Typ. 95 dB
INPUT IMPEDANCE: 100K ohms - (Operable from any source up to 100K ohms, w/ a mixer, HiFi Preamp, Receiver or Tape Recorder)
OUTPUT IMPEDANCE: 600 ohms - (Operable into any Mixer, HiFi Amp, Receiver or Tape Recorder)
INSERTION LOSS: Zero (Slide controls centered, and "OUTPUT ADJUST" control set so that Input equals Output)
MAXIMUM OUTPUT: 7 V into hi impedance, 3.5 V into 600 ohms - (13 dBm).

SPECIAL FEATURES
VU METER: Precision $\pm .5\%$ meter movement provides an accurate visual display, to enable exact unity-gain input output matching
INDUCTORS: Toroidal and Shielded ferrite-core
CIRCUIT BOARDS: Military grade G-10 glass epoxy
RESISTORS: Low noise selected carbon film throughout
SWITCH CONTACTS: Gold plated to assure low noise and reliability
DEFEAT SWITCH: Electrically removes the Equalizer from the circuit
OUTPUT ADJUST: Controls a continuously variable 18 dB range, from -12 dB to +6 dB, to match output to input
RANGE: 12 dB boost and 12 dB cut, each octave centered at 30, 60, 120, 240, 480, 960, 1920, 3840, 7680 and 15,360 Hz.
SIZE: Walnut grained wood case 5 1/2" x 18" x 11"; Rack-panel 5 1/2" x 11"

ALSO AVAILABLE, the **STEREO 20-12-600 .. \$349.50** includes walnut grain cabinet, or rack-mount

Soundcraftsmen: 1310 E. Wakeham Ave., Santa Ana, Cal. 92705 Ph: 714 836-8375

Circle 21 on Reader Service Card

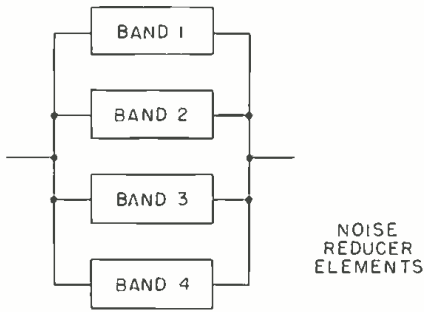

Fig. 3. The Dolby system can do what the compressor/expander could not—noise reduced by frequency, instead of waveform.

If the noise-reducing system errs, in the precision with which it corrects for what it did at the sending end, what happens? The high-level sound is unchanged, because that is not where it works. It just over-restores the dynamic range, and the accompanying noise (or under) as the case may be. Either way, it does not seriously affect program content, by introducing a spurious swelling or breathing effect of its own.

And from the theory and practice viewpoint, which is why we picked it to talk about, it handles the program audio more in the way we hear it, as a collection of frequencies, or tones, where the old compressor/expander combination handled the signal as a composite whole—a waveform of varying amplitude. ■

Copies of db on Microfilm

Copies of all issues of **db—The Sound Engineering Magazine** starting with the November 1967 issue are now available on 35 mm. microfilm. For further information or to place your order please write directly to:

University Microfilm, Inc.
300 North Zeeb Road
Ann Arbor, Michigan 48106
A subsidiary of Xerox Corporation

In addition to Microfilm Copies available through University Microfilm, we have a limited number of regular back issues available. You may order these copies at \$1.00 each from:

Circulation Department
db—The Sound Engineering Magazine
980 Old Country Road
Plainview, New York 11803

don't delay!...

without a Cooper Time Cube*

The only dual delay device available

UREI's unique Cooper Time Cube* gives you TWO completely independent audio delay lines, at less than one-third the cost of a single channel digital unit.

- Cost per MS less than 1/3 that of a digital device
- Lowest distortion, even at low levels (less than .5%)
- Excellent signal-to-noise — better than 70db
- Excellent frequency response, bandwidth 30 Hz to 10 KHz

The Model 920-16 system provides TWO electronically independent delays: One of 16MS and one of 14MS. They can be used separately, in Quad synthesis or for simultaneous "loudness enhancement" of two single channels. Or, the two delay lines may be cascaded for 30MS delay to an "echo chamber" or reverberation device.

Model 920-16 Time Cube is the *only* acoustical delay line system of professional quality, and is designed specifically for recording studio applications and optical film recording.

See your dealer or write for complete specifications.

*Evolved from the original design of Dr. Duane H. Cooper of The University of Illinois, in collaboration with M. T. Putnam of UREI.



UREI company

11922 Valerio Street, No. Hollywood, California 91605 (213) 764-1500
Exclusive export agent: Gotham Export Corporation, New York

John M. Woram

THE SYNC TRACK

● This is being written on the eve (almost) of the 43rd Audio Engineering Society convention. Since I've managed to get involved in the quad session, I've lately been reviewing the past year's activities in quad. Most of the various quad-oriented conferences and meetings have already been discussed in these pages. But at least one interesting gathering has not—the Sixth Annual Audio Recording Seminar held at Brigham Young University. This year the seminar was largely devoted to a look at quad sound.

Bert Whyte was the first speaker at the seminar. In a most enlightening lecture, he recalled some of the early attempts. It seems that the Shah of Persia had a three-channel Edison cylinder many years ago, but it didn't really catch on too well. Perhaps the ladies of the harem objected to the ungainly appearance of the three horns. Bert offered no explanation for the untimely demise of the device. Nor did he mention whether he himself had a hand in getting the Shah started in multi-track. I expect he would disclaim all responsibility. However, he [Bert, not the Shah] has been around for most of the other developments in the state of our art.

Having made some early binaural recordings which were subsequently broadcast in stereo—one side via WQXR-AM and the other on WQXR-FM (New York), Bert found himself visited by some lawyers representing the musicians' union. It seems they were not amused by the goings-on. The union thought that if the musicians were going to be recorded on two tracks, they should be paid double scale. Needless to say, that brought the binaural recording activity to a screeching halt, until Bert and others were able to convince the bad guys that stereo would mean that the whole classical catalog would have to be recorded all over again! Even the lawyers could figure out what *that* meant in terms of union dues, and the rest is history.

Not content to leave well enough alone, Bert recalled his chats with a recording company executive when they talked about the possibilities of an eight-track (!) reproduction system. Mercifully, nothing came of this (so far) but—one day Seymour Solomon of Vanguard invited Bert to drop in at the studio. He wanted him to hear a little something he had just whipped together.

The Berlioz Requiem. In quad.

Again, the rest is history.

Some time later, Peter Sheiber introduced the matrix, and quad sound was on its way—to where we are still not sure.

Following Bert Whyte's lecture, Duane Cooper discussed specifics of some of the matrix systems, and during evening sessions, various matrix manufacturers demonstrated their contending systems.

On the following day, Bill Putnam of United Recording spoke on quad recording hardware, and demonstrated the Haas affect and the use of delay devices in creating quad recordings. Later in the day, Jim Cunningham of Sound Market Recording Co. discussed the problems of quad mix-downs.

On the third day of the seminar, Jerry Ferree of United Recording talked about the tape-to-disc transfer process, with a special emphasis of the problems of quad disc mastering. He was followed by a talk by John Eargle on the theory and practice of live quad recording sessions.

On the final day of the seminar, it was my turn on stage to speak about control room engineering. Later in the day, many of the participants flew on to Los Angeles for workshop sessions at several well known multi-track studios.

All in all, the seminar seemed a most worthwhile project. I trust Brigham Young's Electronic Media Department will continue to offer these summer sessions. Readers interested in more information may write directly to the university, at the address listed later on in this column.

While we're on the subject of education, I've been doing a little teaching at the Institute of Audio Research, here in New York City. In each class, interest runs high on learning more about what a recording engineer is expected to know, and of course, how does one get a job in the industry.

An aerial view of the Brigham Young University.



The Rocky Mountains form a backdrop to the Harris Fine Arts Center of Brigham Young University in Provo, Utah.



Complete tape duplication facilities exist at the Electronic Media Department at BYU.



These questions are also frequently seen in letters to this magazine. Some of the letters are two or more pages long! The writers ask; what do I have to know?, should I study the guitar?, what about math?, should I go to college?, do I have to know how to read music? And on and on. It's hard enough to answer this type of inquiry in class—by letter it becomes all but impossible. When the writer is seeking many hours of advice, it becomes a simple logistical impossibility to keep ahead of the correspondence. If I may offer a few suggestions to the next batch of letter writers:

- Don't write unanswerable letters. Most studios have neither the time nor the personnel to correspond at length with job seekers. Letters to **db** will be answered as time permits, but extensive job counselling takes a lot of time and is really beyond the competence of this writer, at least.
- Better yet, instead of a letter, submit a well-written resume. Don't worry about your qualifications. If you are applying for a beginner's job, you will not be expected to have twenty album credits to your name.
- Inquire directly to the various offices listed below, according to your particular interests.

In the New York area, Smith's Personnel Service advertises an employment service for job seekers in the recording industry, contact:

Alayne Spertell
Smith's Personnel Service
1457 Broadway
New York, N. Y. 10036
212 WI 7-3806

For an International Directory of Recording Studios, contact:

Billboard Publications
165 West 46th Street
New York, N. Y. 10036
212 PL 7-2800

For courses of instruction in subjects related to recording studio work, contact:

Institute of Audio Research
64 University Place
New York, N. Y. 10003
212 677-7580

The Audio Engineering Society offers student and regular membership. In many areas of the country, regular monthly meetings are held. Members receive the monthly Journal of the A. E. S. contact:

Audio Engineering Society
Room 929, Lincoln Building
60 East 42nd Street
New York, N. Y. 10017
212 661-8528

Brigham Young University usually offers an Audio/Recording Seminar during the summer. In the past, these seminars have varied from one to five weeks in duration, contact:

Mr. Dean M. Austin
Electronic Media Department,
140 HRCB
Brigham Young University
Provo, Utah, 84601
801 374-1211 ext. 3761

As for the level of technical competence expected of the recording engineer, it will vary from studio to studio, although I imagine that few studios will expect their mixers to design and build new equipment. Generally, it is far more economical to purchase equipment from well known manufacturers.

But, once the equipment is purchased, you may very well be expected to know how to interface it with your on-hand facilities. This can require anything from a patch cord to a major overhaul.

As a case in point, in the July column I mentioned our construction project for a Dolby assignment system. (Much to everyone's surprise, our system works, and will be described in detail next month.) Now then, we certainly can't improve on the Dolby system. But we can work out an in-

GOTHAM'S MASTER PLAN

To help you build bigger profits

The average recording studio owner backs away from mastering. The equipment's too expensive, he'll tell you. And there's not enough business to justify the outlay.

The average recording studio owner is dead wrong.

Stereo mastering is the most profitable area of the recording industry. It provides the highest return on invested capital.

And for many studios, there's a way to avoid heavy cash outlays for equipment.

Gotham's free "Master Plan" kit gives you the facts. It includes: 1) A valuable Q & A guide to the techniques of disk cutting; 2) A color brochure on our complete Neumann Tape-to-Disk Mastering System; 3) An itemized, 4-page price list; 4) A list of Neumann-equipped mastering facilities—so that you can check on user reactions to our equipment; and 5) Information about how you may be able to lease this equipment from our subsidiary Telden Sales Corp.

Send for your "Master Plan" kit today. This could be the most profitable ad we ever ran. For you.



Staple this coupon to your company letterhead, and mail to our New York office.

GOTHAM
AUDIO CORPORATION

Headquarters: 2 West 46th Street
New York, N. Y. 10036 (Tel: 212-265-4111)

West Coast Sales Office: 1710 N. La Brea Ave.
Hollywood, CA 90046 (Tel: 213-874-4444)

I want to know more about the money-making opportunities of mastering. Please send me your "Master Plan." No obligation, of course.

NAME _____

TITLE _____

Gotham distributes more than 500 products including:

STUDER studio consoles
NEUMANN quad microphones
STELLAVOX mixers
WOELKE wave analyzers
K + H loudspeakers
LYREC tape timers
EMT Reverb units
GOTHAM digital delay systems
EMT compressors
DANNER linear attenuators
EMT turntables
NEUMANN microphones
DANNER rotary attenuators
WOELKE flutter meters
STELLAVOX tape recorders
NEUMANN disk cutting systems
K + H equalizers
EMT polarity testers
STUDER tape recorders
M - W light beam meters



now... equalization using your mind & ears

Creative equalization cannot be accurately, yet arbitrarily adjusted with a few pre-determined switch positions on a control board. There are just too many variables to consider—area resonance, environmental factors, phasing effects, feedback—and many others with many differing characteristics. If you need 3db of equalization at 6510Hz, for example, maybe (just maybe) you can switch in 2 or 4 db at 5000Hz since they're pre-set on your present console.

The problem is—you're not satisfied because what you hear is just not right!

The solution? Full range equalization, giving you the right amount at the right frequency for the precise sound you require. This is the capability of ITI's new *Parametric Equalizer*, Model ME-230.

The Parametric Equalizer lets you vary parameters by ear—accurately and effectively. It combines the spectral response of a 1/3 octave graphic equalizer with the rapid access and economy of a "three knob" system. You can continuously vary frequency from 10Hz to 25kHz via three range controls, boost or cut any amount at any frequency center up to 12db, and adjust shape or "Q" range from 4-14db/octave. And, variation of any one control does not affect performance of any other . . . so you needn't worry about cross-compensating.

If you want more than just 'good enough' performance, start playing it by ear. Our new ME-230 Parametric Equalizer gives you exactly what you're listening for.

To learn more, write or call:



INTERNATIONAL TELECOMM, INC.
Box 405, Hunt Valley, Maryland 21031
Phone: (301) 666-7770



Stan Kenton was recorded quadraphonically in the de Jong Concert Hall at BYU.



A completely equipped control room exists over the concert hall.

terface that takes our particular requirements into consideration. And this is more or less the type of engineering work that may be expected of the studio recording engineer, unless the studio operation is so large that a separate staff attends to this sort of thing.

One does not have to have an extensive education in electronic theory to do this sort of work. Rather, you are dealing with ready-made systems, all of which are assumed to be in working order, and your job is merely to make sure they go together properly. Although his kind of work can just be as involved as electronic circuit design, it requires a different approach. More often than not, you will be working with groups of switches, and routing various signals one way or another, depending on the requirements of the job.

At first glance, the circuit that will be shown next month is about as confusing as any that one might run across. Yet it is really nothing more than a series of on-off switches. Admittedly, there are some confusing interrelationships between the switches, but with the help of a truth table, the circuit becomes reasonably clear. In fact, without a truth table, the design of such a circuit would be difficult, if not impossible. (For more on truth tables, see the March, 1971 column. For more on the circuit, tune in next month.)

THE NATIONAL COUNCIL OF RECORDING ENGINEERS

Some time ago, a group of studio managers got together to talk about the state of the art, as it applies to multi-track studio operation. By the time the meeting was over, a new group had been formed: The National Council of Recording Engineers. The group intends to offer a constructive voice in the development of studio equipment. At the first meeting, there seemed to be some concern about the recently introduced 24 (and more)-track machines. At least some of the charter members felt that the industry

would be better served by further improvements in the 16-track format, rather than by introducing even more tracks at this time. I recall some years ago, when some of the old timers were down on stereo recording. Later on, they just couldn't see why we needed 8-track machines, and so on. I guess I am on my way to becoming an old timer myself, since I have my doubts about the need for more than 16 tracks. However, if we really do need more, let's have them. But if we don't, let's get together and compare notes, and find out what we do need.

Anyone who has bought a new car knows about planned obsolescence, and change just for its own sake. On a more cosmic level we may observe the super powers trying valiantly to build up arsenals for overkill to the tenth power, when once is really more than enough. Somewhere, a long way down the line, the studio people are being bombarded with all sorts of new products, as technology marches on. Sometimes, the new products fill a need, or solve a problem. At other times, we would really rather have an old product that worked well.

Well, now we shall have a voice in planning our requirements. I understand that some manufacturers have already expressed interest in hearing from the Council. This makes a lot of sense, since most studio operators have a very good idea of what they need, and there are at least some manufacturers who haven't got the foggiest notion of what is required in the studio. The Council will attempt to publicize the requirements of its membership, and this information will be available to any manufacturer perceptive enough to take advantage of this expert market research. There should probably be more developments during the AES Convention. In the meantime, any readers interested in participating in the Council are invited to drop me a line, and all inquiries will be forwarded to the proper person in the Council as soon as an office has been set up. ■

Picture Gallery – 43rd AES Convention

NEW YORK CITY'S Waldorf-Astoria Hotel was host to the convention held this September 12th through the 15th. As usual our camera lens was there and it came away with the pictures shown on these pages. If you want detailed information on any of the products shown, circle the appropriate number on the reader service card at the rear of this issue. Material will be forthcoming directly from the manufacturer.

VIEWS AROUND THE SHOW





• Model A80 is the designation for this newest Studer, designed for mastering. *Circle 51 on Reader Service Card.*

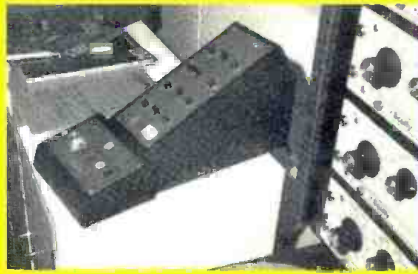

• The Scully Synmaster puts the complete control of the machine on your console. *Circle 75 on Reader Service Card.*



• The Ampex CD-200 duplicating system is for high speed copies made in the cassette. *Circle 89 on Reader Service Card.*



• The newest of the multitrack machines from 3M—the series 79. *Circle 54 on Reader Service Card.*



• This recorder by Tascam uses 1/2-inch tape for low-cost 8-track recording. *Circle 87 on Reader Service Card.*



• Eventide Clockworks now has a digital delay line at reduced price. *Circle 71 on Reader Service Card.*



• Xedit is now prepared to deliver their specialized sixteen-track recorder. *Circle 67 on Reader Service Card.*



• Electrosound produces duplicators for cassette that can run at 240 in/sec. *Circle 72 on Reader Service Card.*



• Four channels of noise reduction are included in the dbx 157 system. *Circle 59 on Reader Service Card.*



• This URL recorder can record quad on both 1/4-inch and 1/2-inch tapes. *Circle 74 on Reader Service Card.*

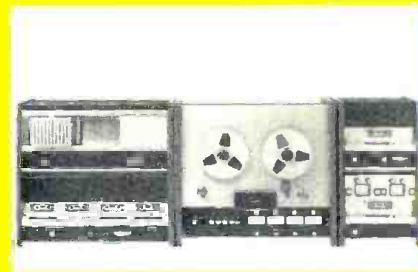

• Infonics' Systems 200 offer a modular system approach to cassette duplication. *Circle 90 on Reader Service Card.*

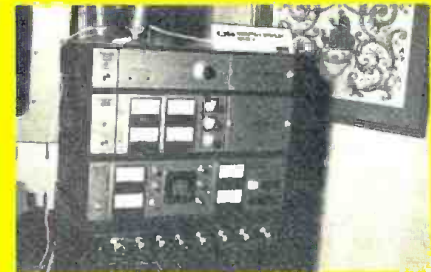

• Completely revised encoder and decoder modules are available from Sansui. *Circle 88 on Reader Service Card.*



• Lower per unit cost is featured in the Dolby up-to-24 channel M24 A-type system. *Circle 61 on Reader Service Card.*

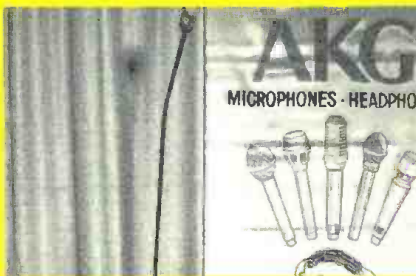

• This AKG microphone can reach into areas in which conventional mics can't get. *Circle 82 on Reader Service Card.*



• The E-V Interface A uses a drone cone to get deep bass out of a small box. *Circle 81 on Reader Service Card.*



• Under the Revox banner, Beyer offers a wide range of ribbon and dynamic microphones. *Circle 58 on Reader Service Card.*



• Stanton Magnetics full line of electrostatic and dynamic headphones. *Circle 86 on Reader Service Card.*



• Shure's latest microphone, the SM54 has improved pop protection built in. *Circle 63 on Reader Service Card.*



• An unusual amount of equalization is provided by the ITI parametric unit. *Circle 66 on Reader Service Card.*

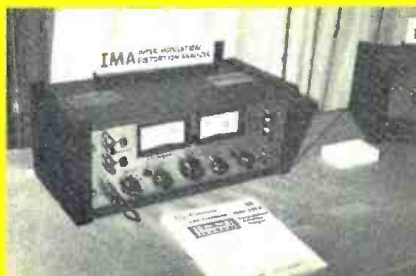

• Crown offers the maintenance engineer this sophisticated IM analyzer. *Circle 60 on Reader Service Card.*

Foot loose

'n fancy free. That's us.



Beautiful schooner.
Exciting li'l West Indies Isles.
And you.

If you're congenial and would like to sail with a small, intimate group, we're for you and you're for us. Now forming to sail.

Your share from \$245.
10 great days. Hurry.
Write today for information.

 **Windjammer Cruises.**

Name _____
Address _____
City _____ State _____ Zip _____
Phone _____

P.O. Box 120, Dept. 970D, Miami Beach, Florida 33139



• Pretty Barbara Brosious of Audio-techniques shows the smallest (Allen & Heath) mixer. *Circle 55 on Reader Service Card.*



• Allison and Automated Processes have teamed up to produce automated mixing systems. *Circle 76 on Reader Service Card.*



• The sign on this new Gately console speaks for itself—it sold at the show. *Circle 68 on Reader Service Card.*



• The UREI Sonipulse is designed as an audio analyzer of room conditions. *Circle 65 on Reader Service Card.*

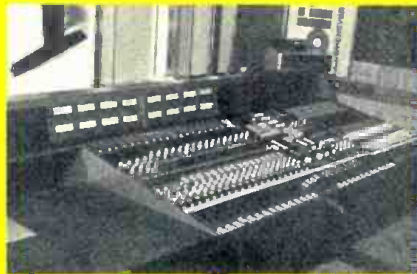

• Olive offers a variety of consoles with built in automation systems. *Circle 64 on Reader Service Card.*



• Not only large consoles; small consoles too are made by Neve. *Circle 53 on Reader Service Card.*

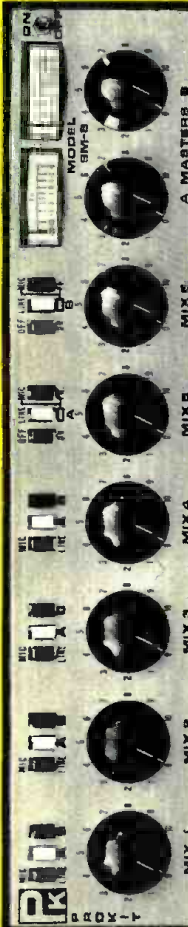

A professional 6 channel stereo mixer at a price everyone can afford. Noise -127 dbm. Output +20 dbm into 600 ohms. Integral VU meters. Switchable mic preamp gain. IC circuitry. 117 VAC or battery operation. Switchable low frequency rolloff. A-B pots. Beyer and Triad transformers. See your dealer or order direct postpaid from Prokit.

\$29900
KIT

\$49900
WIRED

PROKIT DIVISION, GATELY ELECTRONICS
57 WEST HILLCREST AVE. • HAVERTOWN, PA. 19083 • 215-446-1415



• This is Auditronic's new console—dubbed the Son of 36 Grand. *Circle 83 on Reader Service Card.*



• Bill Dilley's hand is seen holding Spectra-Sonic's mini quad pot. *Circle 70 on Reader Service Card.*

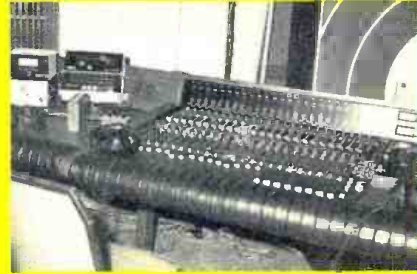

• MCI, known for multi-track recorders also offers this JH-416 mixing console. *Circle 84 on Reader Service Card.*

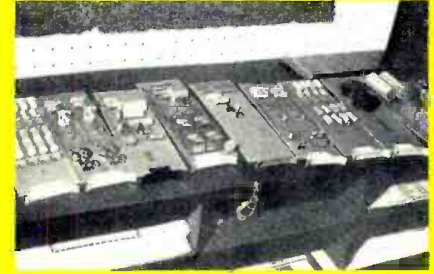

• Fairchild Sound Integra II components permit you to assemble a custom console. *Circle 57 on Reader Service Card.*

Circle 26 on Reader Service Card

Build a Digital Readout Electronic Stopwatch

ALL BROADCAST AND RECORDING studios use some method of measuring elapsed time. The usual method is either a mechanical stop-watch or an electric clock. Both of these methods have their shortcomings. The mechanical stopwatch has a small scale which is easy to misread, is difficult to interface with tape decks and cartridge machines, and is easily broken. The electric clock is easier to read and interface with the studio equipment, but starts slowly and drifts when stopped. There are clocks and watches that get around these problems, but their major drawback is their high cost.

The electronic stopwatch presented here is one answer to these problems. It uses one-quarter inch high light-emitting diode displays, which because of their bright red color, are highly visible at a distance. The rest of the stopwatch with its IC's should be trouble free, and the led's have a projected life of one hundred years. It is also very easy to connect it to a tape deck or cartridge ma-

chine or to remote control it. Since the stopwatch uses the 60 Hz power line for its time base its accuracy (at least in most parts of the country) will be on the order of 0.05 per cent.

The electronic stopwatch is inexpensive to construct, with the cost running between forty and fifty-five dollars depending on the size of the display and local parts cost. This is less than the cost of most good mechanical watches. Finally, it is easy to build and requires no special tools or test equipment.

CIRCUIT OPERATION

FIGURE 1 shows the schematic of the stopwatch. It is constructed using two printed-circuit boards: the larger board holds the power supply, control, counting, and decoding circuits; the smaller board holds the led readouts. The dotted line on the schematic indicates the two different boards.

Referring to the schematic: R1, R2, and C1 filter the

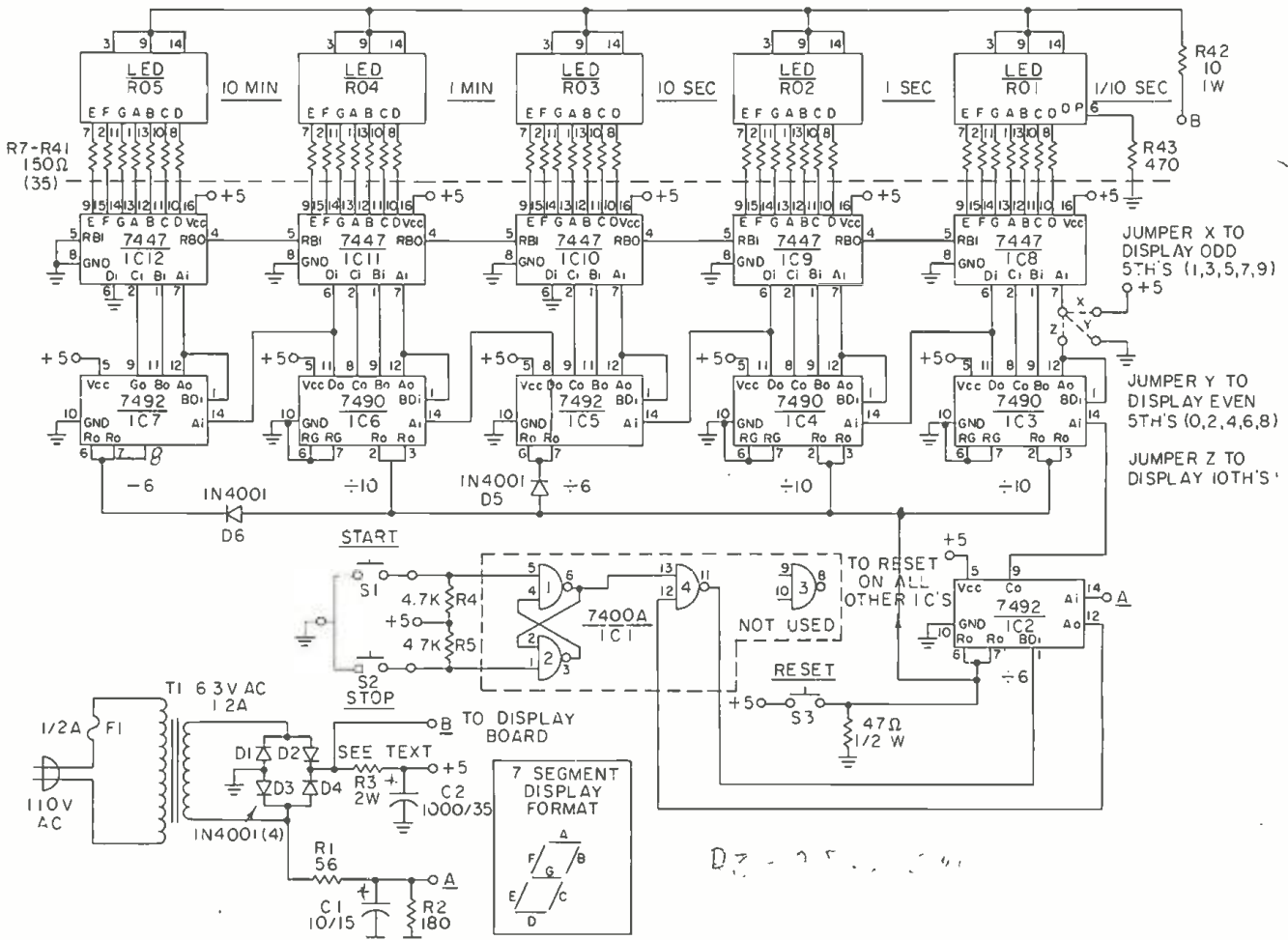

Figure 1. The five digit, one hour electronic stopwatch. All resistors are 1/4 watt unless otherwise noted.

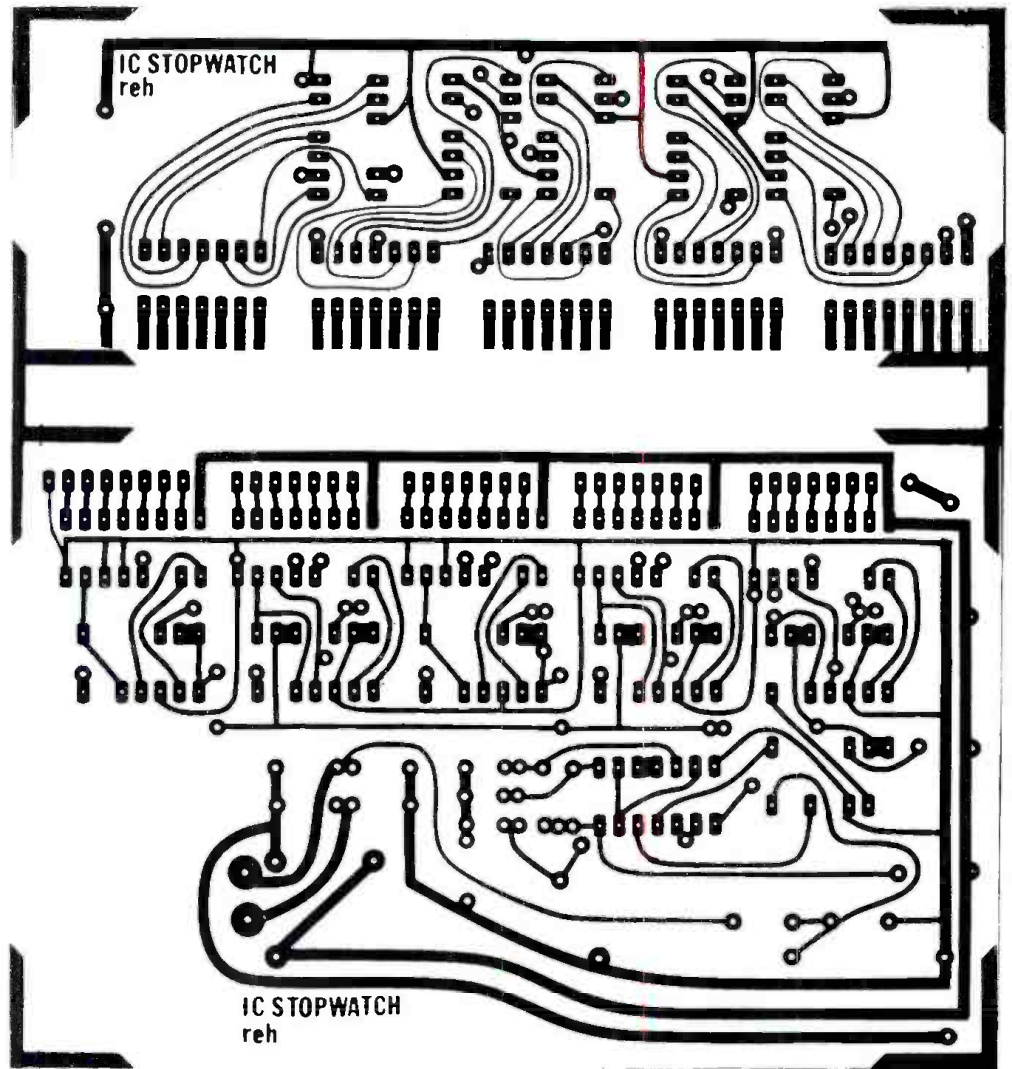

Figure 2. Exact size foil layout.

60 Hz from T1 and feed the conditioned a.c. to the A input of IC2. IC2 is a divide-by-twelve counter which in this circuit is wired to divide by six. The A output of IC2 is connected to one input of gate 4 of IC1 which has four dual input Nand gates. The output of gate 4 is fed back to the BD input of IC2. Gate 4, as will be described later, is used to turn the clock on and off.

The C output of IC2 supplies 10 Hz to the A input of IC3, a divide by ten counter. This counter drives the tenths-of-seconds display. IC3 also supplies one pulse per second to IC4, another divide-by-ten counter. IC4 drives the one-second display. IC5 is a divide-by-twelve counter wired to divide by six. It is supplied with a pulse every ten seconds from IC4 and drives the tens-of-seconds display. It also drives IC6 with a pulse every minute. IC6 drives the minutes display. IC7, a divide-by-twelve wired to divide by six, is driven by IC6 with a pulse every ten minutes and drives the tens-of-minutes display.

IC8 through IC12 are decoding circuits which take the 1-2-4-8 binary-coded output of the counting circuits and

convert them into the logic and current capability necessary to drive the seven segment displays. The decoding i.c.'s are also wired to perform most significant zero blanking. This blanking will cause the left hand zeros to extinguish. If the clock is reset the whole display will extinguish.

The numerals on the displays are of the seven segment type, each segment made up of individual light-emitting diodes. The segments are wired internally in a common anode configuration. The decoder i.c.'s supply seven separate open collectors, each of which is wired to the appropriate segment cathode through a current-limiting resistor. The current-limiting resistor may be any value between 47 and 200 ohms. One hundred-fifty ohms was chosen to keep the segment current down to about 10 mA. Lowering the resistance to 47 ohms will double the display brightness but will also double the segment current and requires greater power-supply current capability. The display brightness at 10 mA is 500 foot-Lamberts and is adequate for most viewing conditions.

Start, and *stop* control of the stopwatch is done through IC1. Gates 1 and 2 are wired as an RS flip-flop. Both flip-flop inputs are held in a high state by R4 and R5, but one of the outputs will be low and one high due to the cross coupling between them. When the *start* button, S1, is pressed it causes gate 1's output to go high and gate 2's output to go low. The opposite will happen when the *stop* button, S2, is pressed.

Ralph E. Hornberger is assistant engineering supervisor at radio station WFIL in Philadelphia.

Option

Remove

R3

1 hour clock with 10ths of seconds	none	2.7 ohms
1 hour clock with no 10ths of seconds	IC8, RO1	2.7 + .27 ohms
10 min clock with 10ths of seconds	IC7, IC12, RO5	2.7 + .27 ohms
10 min clock with no 10ths of seconds	IC7, IC8, IC12, RO1, RO5	3.3 ohms

Modifications that can be done to the electronic clock

As mentioned earlier, the A output of IC2 is fed to one input of gate 4 in IC1. The other input of this gate is controlled by the output of gate 1. When gate 1 goes low, gate 4 is disabled and the pulses from IC2 are not passed. When the gate 1 output goes high—the start condition—gate 4 is enabled and the pulses are allowed to go to the BD input of IC2.

Reset is achieved by causing the reset inputs (R₀) of all the counting IC's to go high momentarily. At all other times this input is held low. To do this the reset bus is grounded through R6. When reset is desired, S3 connects the reset bus momentarily to Vcc causing it to go high.

CONSTRUCTION

The stopwatch was constructed using printed-circuit boards. This is the best method of construction and well worth the effort. A full-size foil pattern is shown as FIGURE 2 as well as a component layout as FIGURE 3. Molex i.c. socket pins were used instead of soldering the i.c.'s directly to the circuit boards. These socket pins are cheap and allow the i.c.'s to be removed if necessary.

If a printed-circuit board is used, install all the wire jumpers first as some of these go under the IC's. It should now be decided if the tenths-of-seconds display will be wired for odd or even fifths or for a full tenths count. The odd fifths are 1, 3, 5, 7, 9; the even fifths are 0, 2, 4, 6, 8. FIGURES 1 and 3 should be consulted for jumper locations.

Next, install the rest of the components being sure to get the i.c.'s oriented properly, pin 1 is next to the small

dot on top of the i.c. When installing the resistors on the display board bend the leads at the bottom of the board flat against the board and, using them as socket pins, insert them into the main board and solder them to the pads on both boards. There is one pad on the display board that does not have a resistor connected to it. Use one of the cut resistor leads and connect it to the main board in the same manner as the other leads.

The stopwatch was not mounted in a cabinet because it was intended for installation in an audio console. Any type of cabinet will do, however. The circuitry is non-critical and shielding is not important. The only mounting requirement is that a piece of red filter material be placed in front of the LED's. This will increase the contrast ratio for better visibility under bright lighting and will also protect the display.

INSTALLATION AND MODIFICATIONS

The stopwatch is very easy to remote control, requiring only five wires and normally open pushbutton contacts. Its start and stop controls can be connected to a spare set of relay contacts on a tape deck or cartridge machine, or to an extra set of contacts on the remote-control push-buttons for those machines. Shielded wire should be used for runs over three feet to prevent induced spikes from activating the control functions.

There are several possible variations of display format. All are achieved by removing i.c.'s and displays. The accompanying chart indicates which i.c.'s to remove and what value R3 will be for each option. ■

PARTS LIST

- C1—10 mFd, 15 volt electrolytic capacitor
- C2—1000 mFd, 35 volt electrolytic capacitor
- D1 to D6—1N4001 diode
- F1—½ amp fuse
- IC1—7400A, Quad 2-Input Nand gate-TTL
- IC2, IC5, IC7—7492A, divide-by-twelve counter-TTL
- IC3, IC4, IC6—7490A, divide-by-ten counter-TTL
- IC8 to IC12—BCD-TO-seven segment decoder/driver-TTL
- R1—56 ohm, ¼ watt resistor
- R2—180 ohm, ¼ watt resistor
- R3—2 watt resistor. For value see text
- R4, R5—4.7K, ¼ watt resistor
- R6—47 ohm, ½ watt resistor
- R7 to R41—150 ohm, ¼ watt resistor
- R42—10 ohm, 1 watt resistor
- R43—473 ohm, ¼ watt resistor
- RO1 to RO5—Litronix Data-Lit 10A light emitting diode numeric display
- S1 to S3—SPST, normally open pushbutton
- T1—6.3 VAC, 1.2 amp transformer, Stancor P-6134
- Misc.—Molex i.c. socket pins, red filter material, fuse holder, line cord, printed circuit board (if used).

REFERENCE

Morris, Robert L. and Miller, John R.; *Designing With TTL Integrated Circuits*; 1971 by Texas Instruments Electronics Series, McGraw-Hill Book Company

Figure 3. The component layout from the foil side.

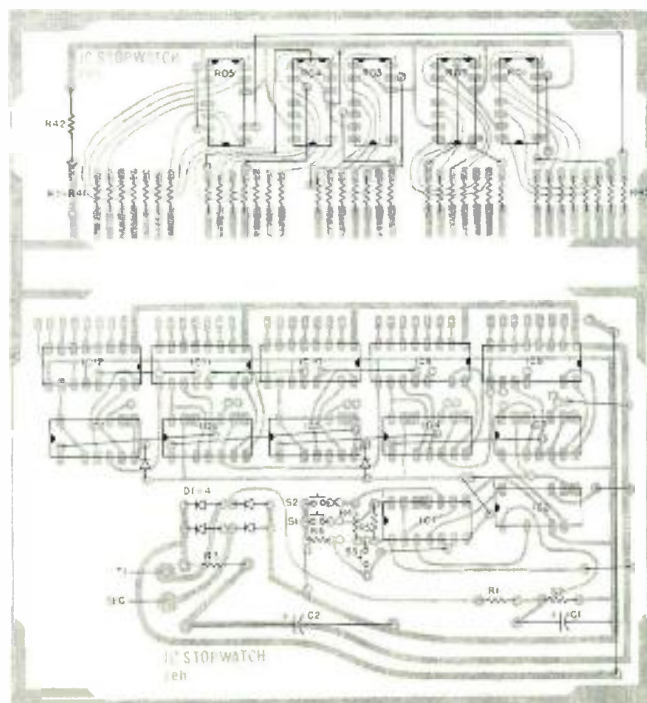

8-9 10
NOT USED AT IC1

Automated Mixing is NOW!

AN OPEN LETTER TO STUDIOS CONSIDERING AUTOMATION

It would seem that the audio industry is again taking a major step forward as it has done many times in the past. The step is into **automation of the mixdown process**. We, at Automated Processes and Allison Research, take cognizance of this and have jointly endeavored to create equipment and systems which are capable of making the step successful. In doing so, we feel a strong obligation to the industry both in the design of our hardware and in the philosophy of its use. What we have developed is the product of five years of research and planning, both in the laboratory and in the mixdown room.

In general, we feel that functional automation, whether for music, film or commercials, requires that the mixdown console or separate mixdown console self-program all relevant control functions in real time. In other words, the equipment must be capable of normal manual operation, but with the additional capacity to remember what was done, when it was done, and how it was done. It must then be able to precisely re-create the original mix any number of times without degradation while individual controls are readjusted to alter or improve any portion of the recording. Since we are dealing with a new technology, there are new terms and new considerations in choosing the equipment. We believe that these considerations must be made clear to the industry if the technology is to be successfully used.

Obviously, the first consideration is that the system work reliably, not only in theory, but in production form. If you were in attendance at the September 1972 AES Convention in New York City, you had the opportunity to witness a production package Allison/Automated system perform under the most demanding conditions. We estimate that between 300 and 400 passes of the same 16 track master tape were put through the console with flawless results. We weren't concerned about putting on such a demonstration, because we had confidence that the Programmer would perform even after the tape was worn.

The second consideration is that the system you buy today must be readily expandable to fit tomorrow's needs. It is easy to claim that a method of programming can be expanded to provide 22 kilofunctions of automation should the need arise. Fine, perhaps the method can, but what about the piece of hardware you purchased? How much expansion can it provide before you run out of room, or power supply, or counting capability? And most important, can it be expanded without making obsolete the data code you laid down in mixing today's tape? Can it provide expansion while maintaining suitable updating rates?

We call our programmer "Model 256E/D", because it is basically a 256 function device. It contains a 256 function card frame, 256 function power supplies, physi-

cal space, connectors, card guides, etc. You may buy it as a 16 function programmer at a 16 function price if you like, but you've still got yourself a 256 function CAPABILITY device.

How do you expand it? Simply add a Model 16E and Model 16D plug-in card for each additional 16 functions. That's all!

The importance of expansion will become apparent when you consider the following utilization format which is based on present or future 24 track capability.

- Function 1-24, individual channel gain
- Function 25-48, individual channel echo send
- Function 49-72, individual channel stereo panning (left/right)
- Function 73-96, individual channel quad panning (front/rear)
- Function 97-192, individual channel equalization (four functions per channel)
- Function 193-216, master levels, echo returns, etc.
- Function 217-256, future functions

Another consideration is updating speed. We believe that updating must be fast enough to faithfully follow the control manipulations of the mixing engineer, yet not so fast as to respond to spurious noise.

When a channel is placed in the WRITE or UPDATE mode, only that channel's control data is changed, while all other data is re-recorded intact. However, to avoid the possibility of error due to signal degradation after multiple passes, all data is completely regenerated each time. This assures that what you hear is what you have stored on the tape.

What about standardization? If you program only fader levels on a tape in Studio A today, what happens a year from now when you attempt to play that tape in Studio B where faders, echo, panning and EQ have all been automated? With the Allison/Automated system, Studio B's decoder knows what Studio A's encoder did, and it performs accordingly and accurately. It permits you to keep the fader level information you programmed, a year ago while you now program echo, panning, and EQ if you desire. You can even take the tape back to Studio A and expect the fader level information to still be valid and accurate. In short, all Allison/Automated systems are compatible. This is no accident. We engineered them that way!

There are a lot of other considerations in automation, ranging from performance of the voltage control amplifiers, voltage control panners, etc., through human engineering and interface aspects, to overall system concepts. We have them covered, and are prepared to discuss any aspects of automation with you. We invite and encourage questions regarding specifications of the components in our system.

Sincerely,

**ALLISON RESEARCH, INC.
AUTOMATED PROCESSES, INC.**

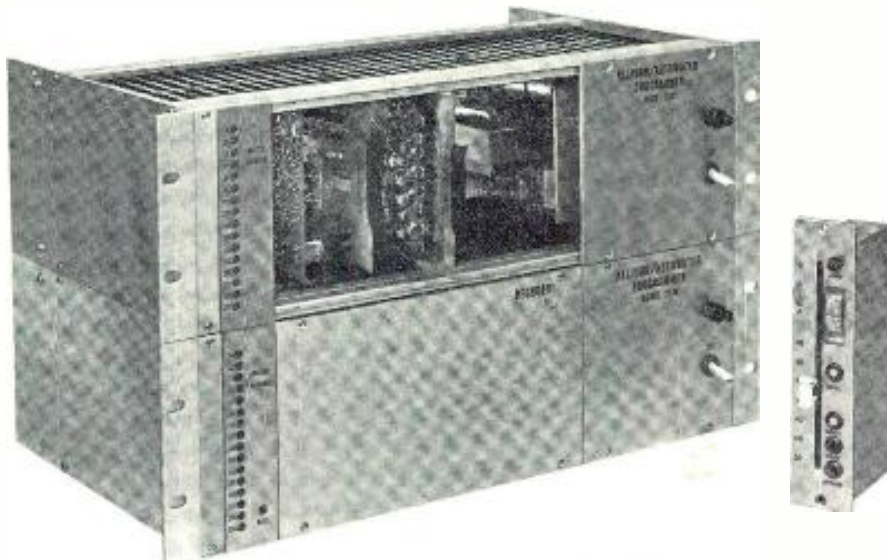

MODEL 256 PROGRAMMING UNIT

At the heart of the system is the Allison/Automated Programmer, designed to avoid obsolescence by being capable of encoding up to 256 channels for recording on any conventional tape recorder. The Programmer contains independent Encoder and Decoder units, each of which employs state of the art analog and digital circuitry. This approach achieves the infinite resolution (stepless) control associated with analog systems while maintaining the error detection capability of digital circuitry.

The Model 256E Encoder consists of a 5¼" x 19" card frame, and is supplied with the Master Encoder module, one Model 16E switching card for 16 functions, and the required power supply modules.

The Model 256D Decoder, a separately packaged card frame with the same dimensions as the Encoder, contains the Master Decoder module, one Model 16D switching card for 16 functions, and the required power supply modules.

Both units can be expanded at any time in multiples of 16 functions by simply plugging in additional 16E and 16D switching cards. The expanded system will continue to decode tapes made prior to expansion. No other adjustment is necessary on either the programmer or the tape machine. In fact all tapes and programmers are interchangeable without adjustment so that tapes made in one studio may be played in any other studio having similar equipment.

MODEL 256 PROGRAMMER SPECIFICATIONS

NUMBER OF FUNCTIONS: 16 to 256 expandable in groups of 16 by means of plug-in circuit cards.

UPDATING RATE: 800 Micro sec/function.

ACCURACY: ± .2 dB, 0 to -40
± 2 dB, 0 to -60
+0 - inf @ -80

BANDWIDTH REQUIRED: 5 kHz (35 dB S/N)

RECORDING LEVEL: -20 to -5 (actual level or level variations have no effect).

DROP-OUT AND SPLICE PROTECTION: Any occurrence of sufficient magnitude to cause decoding error causes device to hold prior information until error signal is removed (Average of 30 sec.).

COMPATABILITY (System to System): Compatibility within ±1 dB. Decoder automatically senses the number of encoded functions present and adjusts its cycling rate accordingly. Decoder also displays (via LED array) the number of encoded functions as an aid to determining the degree of automation on tape of unknown origin.

PACKAGING: Decoder and encoder separately packaged for remote control applications.

Decoder: 5¼" x 19" rack panel.

Encoder: 5¼" x 19" rack panel.

Both units: 10" deep. Self powered.

MODEL 940 AUTOMATED FADER

The Automated Fader is a self-contained channel level control module capable of either manually or automatically setting audio levels. It contains all the electronics and front panel controls necessary to record, play back, and update channel fader settings. In addition, it may be used as an automated master fader, or may be externally controlled for gate or mute functions. An Auto/Manual switch is provided, which allows the module to operate as a normal audio fader, bypassing the automation electronics entirely. The module incorporates a conductive plastic slide attenuator of the same quality and reliability that has made our Model 440 and 475 faders so popular.

The Model 940 Automated Fader fits in the space normally occupied by a conventional fader so that no additional console panel area is required in retro-fit applications.

Electrical performance characteristics are compatible with the Model 256 Programmer. Power requirements are as follows: ±15V @ 50mA, +5V @ 10mA, and lamp power of 5 to 6V @ 30mA.

Mounting Dimensions are: 7" high x 1½" wide x 3¾" deep over mating connector.

You can automate your studio NOW with the Model 256 Programmer and the Model 940 Fader Modules, or with a pre-wired, ready-to-use 16 or 24 channel mixdown automation consolette . . . and there's more to come!

We'll describe the Model 950 panning module and Model 960 echo module in our next automation advertisement.



AUTOMATED PROCESSES, INC.
80 MARCUS DRIVE, MELVILLE, NEW YORK 11746 · 516-694-9212



ALLISON RESEARCH, INC.
2817 ERICA PL. PO Box 40288
NASHVILLE, TENN. 37204

Dial (615) "ALLISON" Or (615) 385-1760

Circle 27 on Reader Service Card

Audio Visuals Under the Stars

A modern planetarium is both rich in the need it has for audio visual equipment, and innovative in the approach to its use.

THE FIRST THOUGHT that comes to mind when thinking of audio visuals in a planetarium is usually of the large celestial-body projector in the center of the theater, and in a great majority of cases there is not much more. Recently, however, more has been added, to both the visual and the audio concepts, right from the beginning of the planning stages.

Just a little over a year ago, one of the twelve largest, and the second most complex in terms of technical equipment, control systems and special effects) in the United States opened in Centerport, Long Island, New York. Owned by the County of Suffolk, it was built at absolutely no cost to the taxpayers. The Vanderbilt Planetarium was constructed and equipped, in just four years, at a total cost of under a \$1,000,000 (compared to others which cost \$3,000,000 or more) with about half of this amount going into audio and visual devices and equipment. Funds were made available from the estate of the late William K. Vanderbilt II, and it is operated under the auspices of the Vanderbilt Museum Commission. Public admissions and the income from a trust fund, bequeathed by the financier to the county, completely cover all operating expenses.

When the plan to build the planetarium was conceived, the Commission called in Mr. James H. Sharp as consultant and then director. He had worked at one of the oldest planetariums in the country for more than ten years and had assisted others in designing other installations. In order to incorporate his ideas into this latest project, he insisted that no plans be drawn up until he was able to become completely active in the very first steps. Throughout the entire planning and construction stages, meticulous care was observed in each detail to produce the most satisfactory surroundings and atmosphere in which the audience could enjoy the carefully designed and produced visual and aural presentations.

Preliminary plans were presented toward the end of 1967 and construction was completed in June, 1971. As with most projects of this size and complexity, work actually went on right up to the last day before the opening presentation.

The structure was designed right from the beginning with constant attention being given to the visuals, sound, and acoustics that would come into play during the performances. With the terrain limiting the over-all outside dimensions to 150 feet in length and 96 feet in width, the question that arose was how to achieve a domed theater which would best allow the types of presentation that were intended to be shown. Knowing the requirements of the types of show to be given, the very large number of

projectors to be used, and with the strong desire to have as good sound reproduction and acoustics as possible, the amphitheater was designed as a separate building within a building. The outer dome was made with a 42.5-foot radius and the inner one with a 30-foot radius.

The outer dome actually never reaches its maximum diameter as it is truncated and mounted on a twelve-sided wall which is dug down to the foundation as a completely separate building from the external masonry and steel structure. The dome itself is made of wood covered with weatherproofing material and tile, and insulated on the inner surface with heavy fiberglass battens which function as sound absorbers to lessen the possibility of reverberation. This entire superstructure is supported also by twelve massive wood arches.

The inner dome, unique in that only one other like it has ever been built before, acts as the screen for the visual presentations. It is made entirely of aluminum and is perforated throughout its entire surface. This permits the sound from the distribution speakers to come through from behind without loss of quality and allows the introduction of rear projection from above whenever this effect is desired. The dome is built on 1-inch square aluminum tubing with 1/8-inch thick walls which had been precurved in the arc of great circles to form a perfect support from above the dome. Such care was taken with this material that junction holes for bolts were precomputed and drilled at the factory so that all these pieces could go together in only the correct way. Its structural accuracy was tested after completion, and the team of professional surveyors who contributed their time to measure 48 radii of the inner dome found it to be off in only

Figure 1. The Vanderbilt Planetarium. The domed portion is actually a separate building within the outer structure.



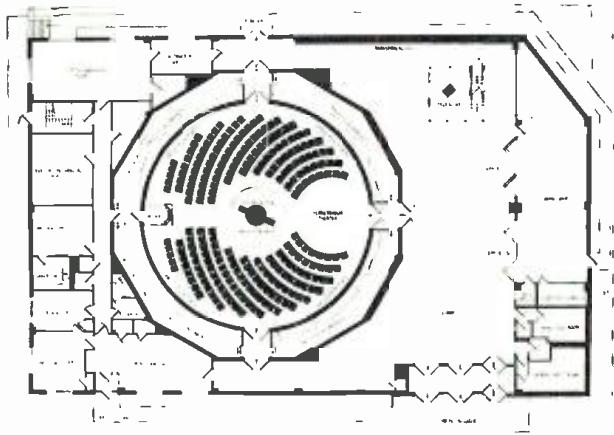

Figure 2. The floor plan of the building showing the seating arrangement in the theater, the control area between the two domed walls, and the work and administrative areas.

one direction, and that by only 7mm.

The area built into the structures between the walls of the inner and outer domes was designed for complete access all the way around. This allows space for operating controls, preset boards, equipment and circuitry, cables and terminal strips and boxes, projection equipment used for the presentations, and sound recording and playback facilities. The dead space between the two walls and domes also helps to deaden interference from external noises. Care was also taken in the laying out of the cables and piping for air conditioning and plumbing to prevent distraction from either a.c. hum or duct noise within the theater.

The central projection for the visual portion of the programs is, of course, located in the center of the amphitheater. This unit, which was estimated to weigh about 3¾ tons and cost more than \$150,000, was built in Japan and is the only one of its kind. The specific details of its concept and construction make it singular in its individual parts and over-all capability.

Mr. Sharp felt that planetarium instruments did not depict the real sky realistically enough. Generally, the stars were shown too brightly on the dome and thus the faint stars were not shown in their true relationship. The number of stars depicted with a brightness of less than magnitude 6.2 was rolled off and the total number did not appear as they would in the real heavens. It was decided that all stars would be shown to a brightness of magnitude of 6.75 and then the number would be cut sharply

Figure 3. The operator's console in the theater.

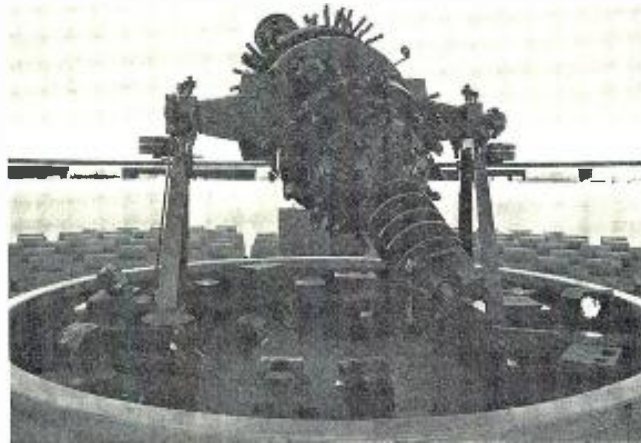
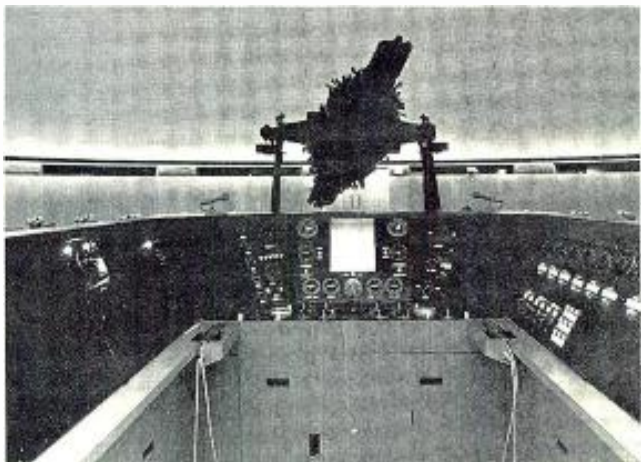

Figure 4. The main projector. Special effects devices can be seen in the black boxes below, and around the perimeter of the wall are the projectors used for the 360-degree panoramic views.

at this point. This way, the stars that appeared on the dome more closely resembled the real sky. Since the number of stars is known to increase exponentially with each increment of magnitude, the number of stars that had to be shown to accomplish the desired effect would be increased by 2,500. The projector was constructed, therefore, with the capability of presenting a total of 11,369 stars, 2,000 more than any other such instrument in the world. This system was checked photographically after completion by taking pictures of the dome stars and then keeping all variables constant on the camera and taking pictures of the same real sky. The results confirmed the accuracy of the projector.

The lamps for this projector were specially designed also. They are made with hand-coiled filaments so that the light distribution would be perfectly uniform omnidirectionally. This precaution was essential as each lamp supplies the source for a full hemisphere of stars and for all of the distribution to appear uniform the same filament surface area had to be presented in each direction. The color temperature of the lamps, which are approximately 1200 watts, is less than 3,000 degrees K. To provide the proper color of the stars, each optical system was fitted with a specific filter to produce a color temperature of 5400 degrees K. The 32 brightest stars have individual filters and optics to assure proper light balance with other stars on the sky field.

The main projector has four motions with direction and speed controls available to the operator at the theater console during a presentation. The drive system consists of four servo motors, 10 watts each, located in the control room which feed through transfer mechanisms, or gearing arrangements, to synchro resolvers.

Synchros on the unit develop a signal which is fed back for comparison with the original signal and the difference is fed to a servo amplifier system which controls 100-watt d.c. servo motors which drive the instrument itself. The output of the drive shafts is also fed to selsyns—which indicate on meters mounted on the console the status of the projector's position. The operator at the console, therefore, need only push a switch forward or reverse (center is off, or no motion) to move the projector in any desired direction while watching for position on the console meters. The meters also provide a means to relocate the projector before showing the next portion of the presentation. (Three of the four movements of the projector are interconnected in the gearing mechanism to assure proper astronomical relationship during rotation.)

The slowest speed of rotation at which the projector can move is one revolution in 1½ hours. The fastest is 1 rpm on three of the four movements and 3 rpm on the 4th. This 90:1 ratio is the widest relationship ever achieved on a device of this type. A protective circuit was also designed into the system so that if the projector is moving at a rapid pace in any one direction, an accidental signal to suddenly reverse its motion would automatically be rejected by the motor system and thus prevent any burn-out or failure in the mechanisms.

Although the celestial body projector is the largest and most costly of any of the visual devices used, it is only one of the several hundred units that are utilized during any of the regular presentations. There are twelve banks of ten projectors each, mounted in special cabinets built around the theater. These boxes are constructed outside of the theater wall itself in such a manner as to allow each projector to be aimed accurately at its area of coverage. The projected images provide a full 360 degree panorama around the base of the dome to depict a view of an ancient city, or the city sky-line, or any scene for which the slides are set up. The registration of each image must be precise to avoid any overlap of adjacent pictures. This is accomplished in the projectors by providing each of the custom-built units with a thumbscrew arrangement which will hold the mounted slide still and in the precise position desired. The machines are fitted with cooling fans, ektographic optics, and use a 300 watt CAL lamp.

To provide uniformity of brightness all around the room and to be sure that the total image would accurately line up at all intersections, each of the projectors was checked for focal length and light output. The units were then positioned to provide the best possible viewing by the audience, with the best possible throw distance for

each unit. With each show running approximately three months, the relamping of each projector when the slides are changed has resulted in no burnouts and no down-time for any of the units.

Other projectors available for use in any presentation include 22 standard Carousel projectors using DEK (500-watt) lamps, six super-8 continuous loop film projectors, five projectors for 16 mm film which use 200-watt lamps, and sixty other projectors which utilize either 500-watt quartz lamps or 18-watt incandescents. In addition, there are six slide projectors located at the center of the theater, under the main projector, for casting montage images on the dome. Each of these units uses a DEK lamp and each is set up with a drum containing 81 slides. Each is operated by an automatic timer which is started at the proper spot in the presentation. The projection distances are short for these projectors due to their location directly under the dome. To avoid excessive brightness of their images compared with other projectors, the optics on these projectors are closed down to the proper setting for projection balance.

There are also two random-access projectors available which are used primarily during presentations that are specially prepared for school classes. Each of these units is also provided with a full drum of 81 slides and is under the control of the lecturer or the operator in the rear control room.

In addition to the above equipment, 50 to 60 mini-projectors, made by the Minolta camera people, are normally used during a typical presentation. These are no longer being made but a total of 200 are presently available at the planetarium for use in whatever quantity or capacity required. They can be used with regular slides or for special effects. When used in this latter function, for example, various mechanical devices can be built into

The Quad/Eight Gate

NS-120

The fast, accurate,
flexible
noise gate.

\$98.

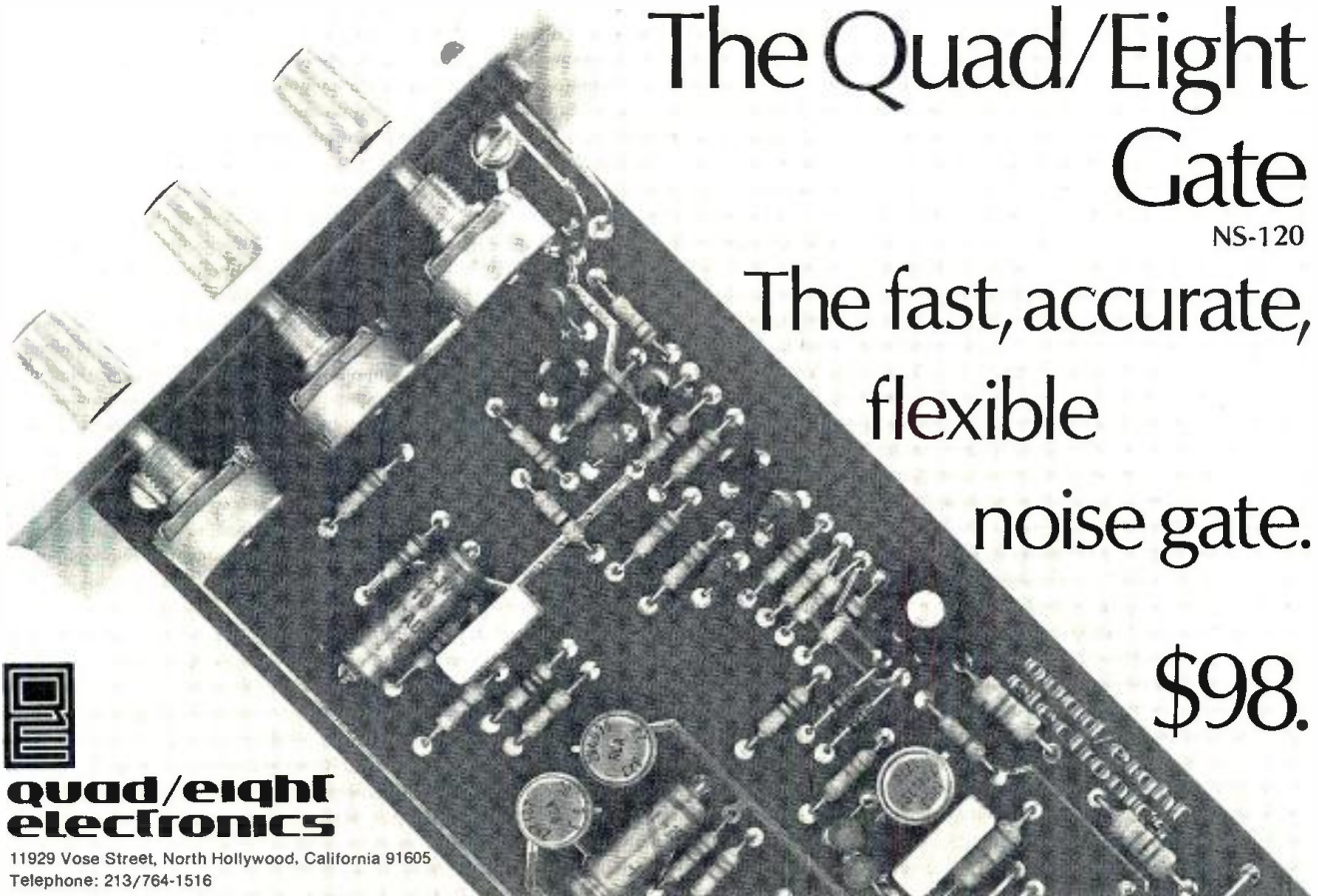

**quad/eight
electronics**

11929 Vose Street, North Hollywood, California 91605
Telephone: 213/764-1516

Circle 31 on Reader Service Card

the focal plane to produce image motions as required by the show. Electronic flash units can be substituted for the regular lamp and condensor lenses to produce lightning and other flashing effects.

Special devices are also used during shows as needed. There are five dissolve units, three of which can be used at any one time with the ektagraphic projectors. There are several dozen special projectors which have either been built from scratch as needed or are modified standard units. One unique device that was designed for a specific need is located at the center of the theater under the main projector. It consists of a slide projector on which is mounted a 16 mm film lens. The lens is a zoom type and is capable of remote control. The iris built into the optics was linked with the zoom mechanism so that as the image zoomed out to become larger and larger, the iris opened to provide more and more light. As the image zoomed in to a smaller size, the brightness was kept constant by the closing of the iris to cut some of the light along with the decrease of image size. The variable speed control lever on the console is moved in the direction of the desired zoom and has a center cut-off. A meter located on the console shows the operator the position of the zoom lens. This meter is a standard VU meter with the scale replaced by a more appropriate one.

Another special device that was custom built for use during presentations consists of a mechanism which will rotate a slide from an edge-on position to a full frontal view directly in line with the light source. The light itself is also mounted on a motor driven arm. This device permits effects such as showing a rotating galaxy at a distance in oblique view and then having it come in toward the observer and simultaneously revolving to a full head-on view of the entire star system.

This extensive and complex visual display capability is

operated from the master console located at the rear of the theater and from a position in the rear control room. Access to the console operating area is from the rear control room only. As the operator enters the console area it surrounds him on three sides. On the left, the console has controls for the two random access projectors used in the school presentations, the start/stop and volume controls for the program tape units, and a switch to turn on and off the public address amplifiers. There is no volume control for this system as the amplifiers have been preset to the maximum level output before feedback. This operation has proven very satisfactory.

At the center of the console, directly in front of the operator as he faces the celestial object projector, are a horizontal panel and three vertically inclined panels. At the center of the position there is a cutout for the operator's program script. Controls on the vertical panels are for regulation of the brightness of planets, horizon glow, house lights, and also changes in latitude and processional. There are also controls for console lighting on this panel. The horizontal panel has controls for showing coordinates on the dome, individual dimmers for the sun, moon, and stars, and a master dimmer control. The horizontal panel also has controls for regulating the speed of heavenly motion through time such as the daily motion, and the orbital motion of the planets.

On the right side of the console, a myriad of variacs, potentiometers, and switches give the operator control of 24 power circuits with 1200-watt capacity in each, control of six of the available fourteen circuit dimmers each capable of 6000 watts, and control of individual projectors as preset in the master-control area.

There are two arrow projectors also available for the operator at the console. These are specially wired to permit freedom of movement during the presentation—

Mixdown tonight. 16 track. How's your memory?



COMPUMIX™

The Number's Game.

Check our bingo number and, in addition to complete technical data on Compumix™ we'll send you a free copy of "Automation Arithmetic - or How to Slice-up the Automation Pie". It discusses the basics of digital information storage as applied to audio. We hope it will help you understand this new technology for sound recording.

Above, the Compumix™ controller. Our memory helper. Trust it. It's designed to interface any mixing console to our digital processor. 46" long, 16" deep, and 2" thick. Small. Everything's there. More than enough level and switching control for the heaviest 16 track mixdowns.



**quad/eight
electronics**



Figure 5. The recording studio and mixing console, with Mrs. Sharp in the narrator's chair.

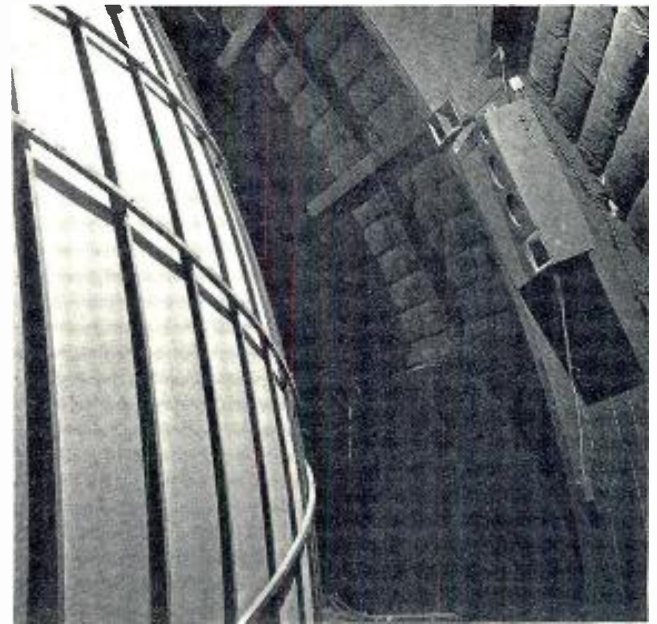

Figure 6. One of the two program sound distribution speakers. It is mounted on a structural member of the outer dome and aimed toward the audience through the inner perforated dome (the sky for the presentations).

to point out desired constellations or stars.

The master-control room is located in the space which lies between the inner and outer walls of the domed areas. It is here that division of control functions is set up for the console and the control room. On one large board, there is a master setup panel with 120 moveable levers with 82 positions each. This capacity allows the presetting of any projector, device, or special-effects unit to be controlled by the desired switch or potentiometer either on the console or in the rear or from a fully automatic programmer now in the design stages. These choices are made during the show presetting period, prior to beginning public presentations. Although the settings are usually not changed during a show, there does exist here the ability of switching quickly in the event of a failure or breakdown.

In the wiring of the various circuits during construction, the cables were run through a box 8-feet long and 4-feet wide which is mounted on the wall in the rear control area. This box contains many terminal blocks and most of the seventeen miles of cables are fed through these connection points. This also permits changing control circuitry and allows for the addition of new control functions should this become necessary. Other system changes are also possible in a network of twelve-position terminal strips located in a readily accessible position in the control area. A future capability was also built into the 24 dimmer circuits on each of which there is a switch. The spare contacts on the switches are presently not all in use but are readily available for the connection of any motor circuit that may be needed, to be turned on prior to fading up the corresponding projector lamp dimmer.

To facilitate operation of the many controls that must be utilized during the presentations, the work is divided between the operator at the console and the one in the rear control room. The console is generally given control over the various zooming devices, about a third of the special effects units, sound level in the theater and operation of the main projector. The rear control room handles the panoramic projectors, the remainder of the special visual effects and has responsibility for watching over the audio tapes and equipment during the shows.

Just as with the visual portion of the presentations, extreme care was taken in the choice of equipment and the method of production and distribution of the aural segment of the shows. The entire sound presentation is pre-recorded on ¼-inch tape and played from Ampex AG445 decks. Two machines are run simultaneously, with one acting as a continuous backup with immediate switch-over capability in the event the one playing the show should fail. To permit a single tape to be used for the entire show, rather than having to switch during the show, the tapes are on 10½-inch reels and running at 7½ in/sec. This allows an uninterrupted performance, with entry and exit music, totalling approximately 75 minutes. The stereo tape machine plays each of the two separate tracks on the tape to individual amplification and distribution equipment.

The program power amplifiers, made by the Schober Organ Co., are rated at 40 watts and have a frequency response of 29 Hz to 20 kHz. The amplifiers were put through a torturous test prior to selection and proved themselves completely stable and reliable. Each tape track feeds its own amplifier which in turn drives individual speaker units. This stereo arrangement permits use of special sound effects, stereo dialogue and either stereophonic or mono music. The speakers are mounted on the structure of the outer dome with approximately 90 degrees separation and distribute the sound through the perforated inner dome to the entire seating area. Each of the speaker units consists of two Schober 12-inch woofers, one Altec 511 sectoral horn with 808 driver (and 500-Hz crossover with shelving control) and a custom-designed housing with a ducted port to augment the 27-Hz resonance of the bass speaker.

The public-address system, used during school programs and lecture presentations (also available for emergency use) is comprised of two E-V RE15 super cardioids mounted on the console, two amplifiers identical to the program units which can be used as spares, and two speakers mounted on the outer dome and facing directly into the null points of their individual microphone to lessen the possibility of acoustic feedback. These speaker units are also made with ducted-port housings containing

a single Schober 12-inch woofer, an 8-inch mid-range speaker and a small high-frequency horn. In addition to the two inputs to this system from the console, there is a third from the open area of the 234-seat theater to permit the lecturer standing in this location to be seen clearly by all the youngsters attending the special school presentations. The three mic inputs feed Automated Processes preamps.

The public-address system also has been wired up to feed a monitor speaker in the director's office and another monitor in the rear control area. This latter monitoring capability allows the console operator to throw a switch on the console to cut off the house p.a. speakers and talk directly to the personnel in the rear control room.

With the entire audio portion of the program on tape, all the recording and mixing is done by the planetarium technical staff in a studio specially built into the facility. The window for the separation of the studio from the recording control room is built into the wall of the outer domed area with the recording equipment and mixing console in the main control area. The microphones used consist of an E-V 664 and two E-V RE55's. The mixing console specially built for the requirements of the presentations, has six input positions and an additional switching matrix permitting any six of a total of twenty sources to be fed into the console in stereo pairs. The console has two outputs and a separate vu meter on each.

The input sources available to the mixer, in addition to the microphones, are any of three mounted Revox tape machines or a portable unit, a turntable and an fm tuner. All recording is done on the Revox machines, and then mixed through the console, at 15 in/sec. After the music and sound effects have been put down on tape, the mix and a separate voice track are fed through the console into the theater. The best balance between the two is then worked out while listening in the area where the blend will be reproduced for the showing. It is only then that the final mix is made to the 7½ in/sec. master reels. The mixing system has a response of 25 Hz-25kHz. The ability to feed a tape through the console into the theater, separate from the two master tape decks, provides still another safety measure. In the event that both Ampex units become defective at the same time (which is unlikely since even the added precaution of separate power feeds has been incorporated into the wiring) the show can still go on from the mixing console with one of the Revox recorders.

In order to keep up with the latest in the audio field, a four-channel encoder has been installed in the sound rack in the control area. Although this is not in the system yet, it does provide the beginning of later improvements and additions to the sound system in a continuing attempt to enhance the enjoyment of the presentations.

Another example of the desire to enrich the effects of each of the shows, and the innovative capability used in the preparation of the program material, was evident in the very first presentation offered by the planetarium, called, appropriately, *Beginnings*. The birth of the universe was depicted in this show, and it was desired by the production staff to have lightning and heavy claps of thunder. Pre-recorded material available at that time was found to be unsatisfactory. The two RE55's were run out to the outside and opposite ends of the building and mounted under shelter to wait for a thunder storm. After several such storms, and some close strikes of lightning, the desired sounds were recorded. The thunder reproduced at full level during the show left no doubt that this was the real sound.

Similarly, in the visual presentations, all slides are shot by the staff photographer and developed in the planetarium's own lab to create the effects desired for the partic-

ular needs of the program. All art work for photographing is also developed by the staff artist.

Outside of the domed areas, in the lobby of the planetarium building, there is a display of transparencies showing various celestial objects. There are also two rear screen presentations using Carousel projectors with 81-slide trays. In a glassed-off area near the center of the lobby, there is a telescope which is available to the public under the guidance of a staff member to view the real sky on clear nights—following the main evening presentation. Those members of the audience who prefer to listen to a talk on constellations are permitted to do so in the theater in lieu of looking through the telescope.

The telescope is built with two mirrors of Cer-Vit material which have a zero coefficient of expansion to ensure constant image quality under changing temperature conditions. The base for the unit was specially built separate from the main building by pouring an eight-ton concrete pier. The drive mechanism for the telescope is run by an audio oscillator and power amplifier and a synchro motor. There are five drive motors in all. Course adjustment is made by hand and fine control is electrical. Once the telescope is locked onto a star, the tracking is automatic. The 16-inch aperture, 4-meter focal length optics permit photography of stars to the 16th magnitude, and visual observation to about the 13th magnitude.

The entire project, right from its inception, has had meticulous care in all its phases. The innovations that have been and will be developed for improvement of the presentations will continue to provide visitors with realistic, entertaining, and exciting displays, for all members of the family. Reservations by calling the planetarium can be made all year round. ■

FREE

(THIS IS NO BOOK FOR AMATEURS.)

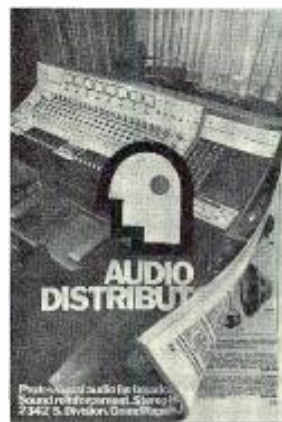

It's crammed with pictures, poop, and prices. Features top grade electronics from around the world. Strictly for professional audio, broadcast, television, recording and motion picture moguls. We specialize in fast, off-the-shelf delivery on recorders.

Duplicators. Microphones. Turntables. Reverbs. Amplifiers. Attenuators. Equalizers. Compressors. Speakers. Broadcast and recording consoles. Write for your free copy of our catalog today.



AUDIO DISTRIBUTORS, INC.
2342 S. Division Avenue
Grand Rapids, Michigan 49507

Circle 24 on Reader Service Card

APRS — '72

The author details some of the highlights of this professional audio exposition which was held recently in London, England.

THE FIFTH ANNUAL EXHIBITION of professional recording equipment of the Association of Professional Recording Studios was held at Connaught Rooms, in London, June 23 and 24. This event is purely and simply an exhibition of equipment, with no meetings, papers, banquets, or other diversions to interfere with the business of demonstrating recording gear. From the manufacturers' viewpoint, this has some definite advantages, such as maintaining high traffic throughout the exhibition day (11 a.m. to 11 p.m.).

U.S. equipment, generally represented by the U.K. distributors, was much in evidence and included Crown, Shure, Koss, 3M, MCI, CBS Broadcast Products, Eventide Clockworks, Burwen, Gotham, Moog, Switchcraft, Amphenol, Moog, Exedit, and JBL.

In touring the exhibition *stands* as the British call them instead of the familiar *booths*, one had to be struck with the move into manufacturing by studios large and small. Two very well known British Studios, Lansdowne and Trident, both were showing their highly sophisticated 24-track mixing *desks* (again using the British nomenclature) while another big name in London studios, Orange, was getting a lot of attention to their 24-track recorder, designed and built by their own engineers. By actual count, over twelve of the exhibitors were offsprings of recording studios.

Of the U. S. manufacturers, most interest was attracted by MCI, which shipped over a 16-track and 24-track recorder plus a 20-track console. MCI president Jeep Harned and the author, the MCI exporter, were both on hand to plug their products.

New product interest centered for the most on some of the newer digital devices, such as digital delay lines, phasing devices, voltage-controlled attenuators and various noise reduction devices plus peak program meters, pulse modulation equalizers and mini mixers. A super mini mixer by Allen and Heath offers six inputs with stereo panning, three range equalization, echo send, and faders, and two outputs with vu meters, slider faders, and echo return equalization, and all for \$395. Size: 7½ x 10 x 1 inch . . . how's that for a pint-sized package?

In an overview, the APR '72 show seemed a lot like the AES during the Barbizon Plaza days; about the same number of exhibitors, slightly more attendance and really, not too much new but some interesting methods of arriving at the same place.

The exhibit was well attended by engineers from the continent, with France, Germany, and Belgium well represented along with a good showing from the Scandinavian countries. If you can fit it into your travel plans next year, do it. You'll have a ball. ■



Dagmar Dolby and Dolby sales manager Ioan Allen deep in discussion—on what we didn't find out.

Ham Brosious is president of Audio-techniques, Inc. of Stamford, Connecticut. He was at APRS-'72 as both exhibitor and spectator.



The Amity Shroeder stand (Orange) proudly demonstrated the first 100 per cent English-built 24-track recorder as onlookers ponder its impressive size.



Stuart Young of Allotrope, Ltd., listens to a question from film and sound specialist R. W. Mitchell (at right) about PML's new f.e.t. condenser microphones.

Neve installs consoles in hours- not weeks

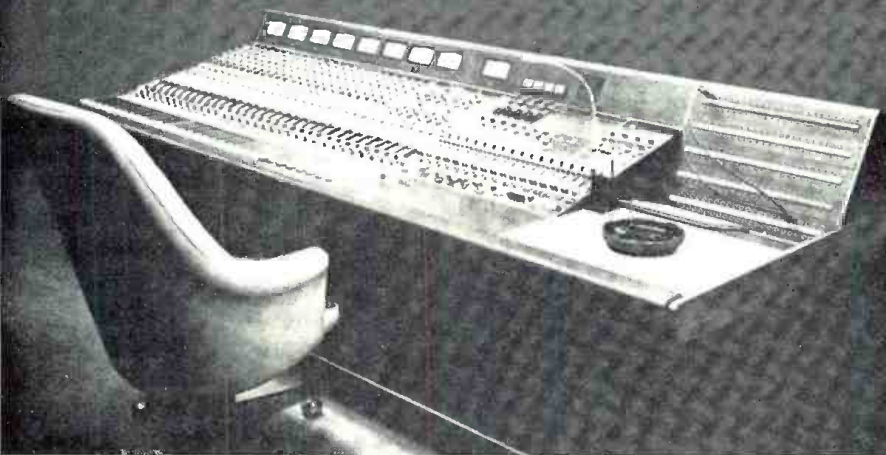

Neve Console in André Perry's Studio "A," Montreal, Canada.

Rupert Neve, Inc.: Berkshire Industrial Park, Bethel, Conn. 06801. (203) 744-6230.
Hollywood: Suite 616, 1800 N. Highland Ave., Hollywood, Ca. 90028. (213) 465-4822.
Rupert Neve & Co., Ltd.: Cambridge House, Melbourn, Royston, Herts, England.
Rupert Neve of Canada, Ltd.: 7528 Bath Rd., Malton, Toronto, Ontario, Canada. (416) 677-6611.

Can't believe it? We'll prove it.

Neve can install a sophisticated, perfected, thoroughly tested Sound Mixing Console (like the one shown) in your studio in *less* than a day.

So you can start using it immediately. Instead of waiting indefinitely.

Reason: All modular components are built precisely to specs. Designed for ultra-fast installation. Another surprise: *no* bother with in-studio modifications later on. Neve Console craftsmanship is unmatched. For example: fantastically low distortion (never above 0.075% at 1 kHz).

On-time delivery? It's *always* a matter of policy with Neve. And a matter of honor as well. We'll custom-design a console for your particular needs. We also offer a wide choice of stock audio control consoles. Neve Consoles are used in major studios for music recording, broadcasting, ad commercial, and motion picture production — in 24 countries.

The sound of Neve is world wide. Write for more facts. Now. You'll never be disappointed — with Neve.

Neve

Write for Bulletin DB-1



The Koss display was always busy. Noted British composer Barry Gray (front right) and Roger Arnhoff from Oslo (immediately behind) listen to a presentation by George Tughan, Koss distributor for the U.K.



The Alice Development, Ltd. stand showed a number of small mixing desks—and one semi-professional mixer. Those Alice chaps have an eye for development!



MCI president "Jeep" Harned explains features of his JH-416 console to Gerhard Lehner, chief engineer of Barclay Recording, Paris. Author Ham Brosious (center) and Dag Fellner (right, standing) look on. Mr. Fellner is the managing director of Feldon, importers of MCI for Europe.

CORRECTIONS

In Automating the Audio Control Function, part 3 (August-September issue) the following errors need correcting on the schematic of Figure 5(B), page 50:

- Pins 2 and 3 of A4 should be interchanged.
- R26 and C3 should be connected.
- The unmarked connection from DPS to +15 V is pin 9.
- R18 is 470 Ω not 470k.
- The values for the parasitic suppression resistors should be 470 Ω .

- In Figure 2 on page 47, C6 connects between pins 1 and 2 of op amp 301A.

* * *

We trust that no one was misdirected by an artwork error on page 24 of the July issue. In Figure 4 of Lou Burroughs' article, the parallel cable arrangement was mislabeled on the right hand side. The contacts should now be indicated at 2-3-1 in the upper right. In all cases the same numbered contacts are interconnected for paralleling.

Martin Dickstein

SOUND WITH IMAGES

Convention Coverage

● As indicated here in July, we were able to visit the VidExpo 72 Conference held during the latter part of August at the Roosevelt Hotel in New York, and we hope that others of you were also able to attend. For those who could not, this brief report will attempt to bring you up to date on the talks and exhibits that were presented. But, first, a word about the sponsor.

Billboard Publications, Inc., New York, publishes the magazine Billboard, the leading international music/record/tape newsworthy. They've done this for the past 78 years and have, in that time, expanded into other fields of communications, entertainment, and most recently, into video business. A quick look at the list of magazines published by BPI would show Vidnews, the biweekly video newsletter; Merchandising Week, the

only newsworthy for home electronics, housewares, and the major appliance industries; Photo Weekly, the only once-a-week business paper for the photo industry; High Fidelity, the monthly with which almost all hi-fi enthusiasts are familiar; and similar magazines in foreign countries. (Incidentally, all of these publications were co-hosts of the conference.) BPI also publishes Modern Photography, Stereo, and other special-interest magazines; owns four catv systems in Massachusetts, a special-order record/tape warehouse, and other enterprises in various communications areas; and also programs stereo entertainment for American Airlines, Air India, South African Airways, Pan Am World Airways, and Olympic Airlines. Now, with the birth of the video cassette-cartridge-disc-film market, BPI became involved in that direction, or-

ganized an international convention in this field in Europe, and followed up with VidExpo 72.

The conference was the first "user-oriented video marketplace," tuned to those who will use the media and equipment in this new field for industry, education, sales promotion, advertising, and for home distribution through catv and individual purchases. Four major divisions were discussed in the talks that were given and then in panel discussions: Government and the Video Media; Educational Video; Corporate Video; and Consumer Video. All are related to those who will be buying and using the hardware and software in various applications.

The keynote address in the Government category, Rep. Orval Hansen (R.-Idaho), Chairman of the GOP Task Force on Training and Education, revealed that he will introduce new legislation and announced that new funds would become available for educational programming. The new legislation would seek to establish an Educational Technology Council in HEW.

During his talk, Rep. Hansen said: "My involvement with the educational aspects of television only dates back a few years but during that period of time I have grown accustomed to

"What I need is a recording console that's expandable to 26 in., 16/24 out; with full quad capability; and FET logic automatic rec./play mode switching. But it would cost me \$36,000 or more."

"What you need is Auditrionics!

"Son of 36 Grand"

It's got everything you need for about half the cost."

For more information on the Son of 36 Grand, write Auditrionics, P.O. Box 12637, Memphis, Tenn. 38112.

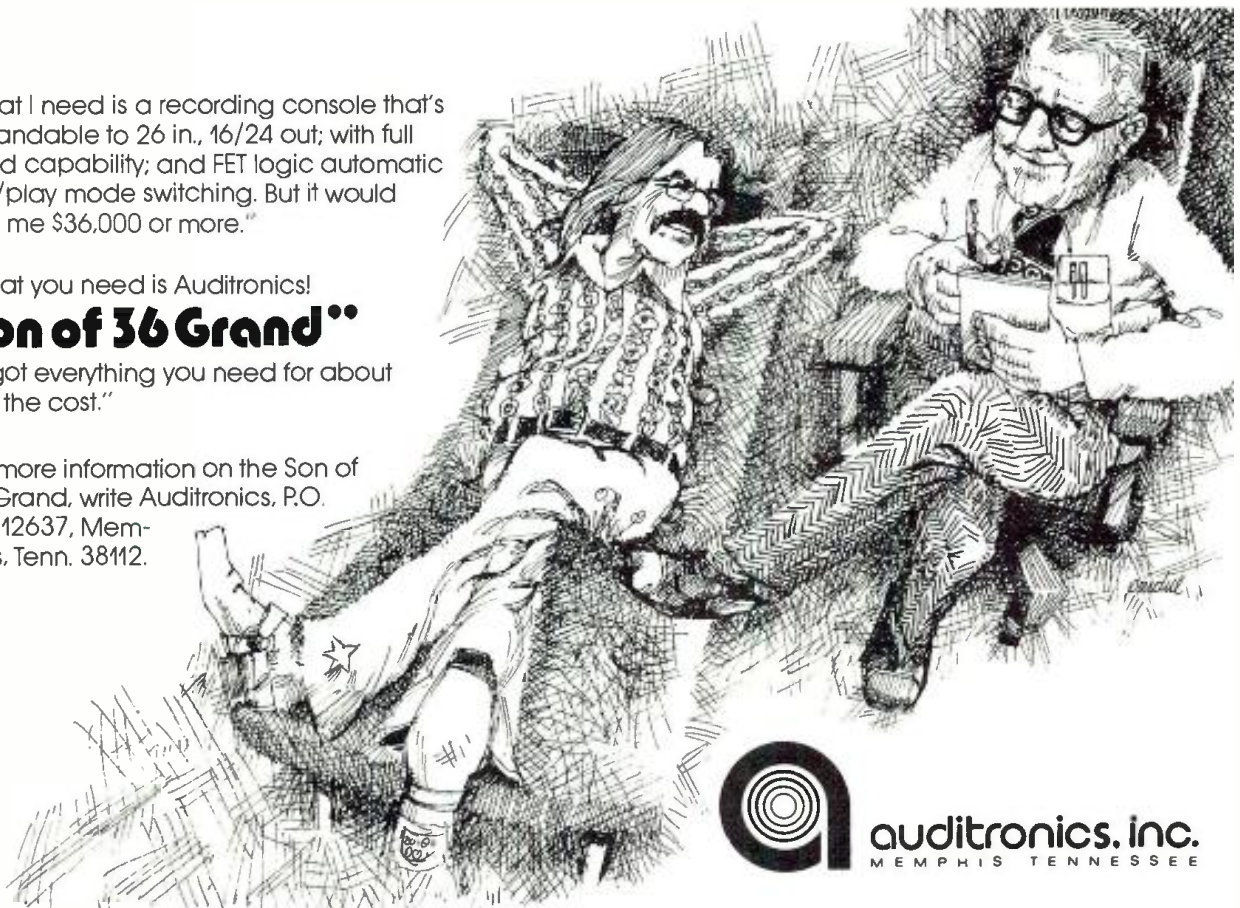

auditrionics, inc.
MEMPHIS TENNESSEE

Circle 19 on Reader Service Card

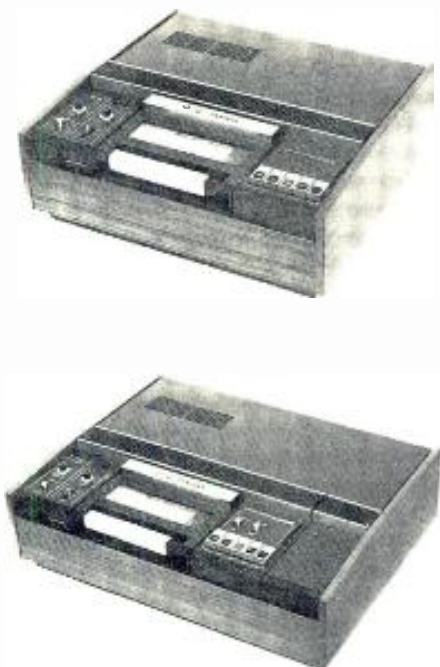

Concord Electronics' player and player/recorder for 3/4-inch video cassettes.

hearing the revolution in television referred to in the *future* tense . . . But sometime this summer, a corner was turned and now, it seems, everyone is referring to what is happening in television technology in the *present* tense

"In the educational world, however, I'm afraid that we still may need to use the future tense a while longer. There can be no doubt about the importance of the emerging video technology for education. It gives teacher and pupils a flexibility and range of possibilities which were previously impossible to achieve and opens up a rich wealth of programming opportunities heretofore unknown.

"Most educational budgets are spent on teaching staff, and the quality of education—in so far as money can influence it—depends largely on the interaction between this staff and the pupils. The whole new world of video tape opens up countless possibilities for affecting this interaction—making wider resources and techniques available to both students and teachers in a cost effective manner."

After discussing the problem of allocation of funds to the individual states and school districts and the application of the money to investment in new technologies with the inherent problems of not enough, he continued with some other problems that had to be faced in the field of education with regard to the incorporation of the video medium and the appropriate software.

"A second factor inhibiting the acceptance of video cassettes is the

compatibility problem. Some of you may have heard me speak about this at a meeting sponsored by the International Tape Association in June, here in New York. At that time I outlined some of the findings and proposals of the House Republican Task Force on Education and Training which I chair, and I would like to repeat them today. First, we found, as I have already stated this morning, that the video cassette is one of the most important new educational tools to come along in generations. The combination of flexibility and relatively low cost make it a natural for adoption in the schools across the nation. But educators have thus far successfully resisted providing manufacturers with precise descriptions of the qualities they need in products to facilitate the education process. They have seldom even come up with an accurate definition of the instructional objectives they hope to reach through the use of the equipment. Some attempt must be made to specify educator's needs before manufacturers can respond to them.

"We found also that a serious information gap exists. The educational consumer does not have and cannot get adequate information regarding the relative capabilities of a given video recorder/playback device as compared to another. Advertisers' claims are about all there is to go on, and that's not enough. Too many educators have found that the tapes recorded on one machine cannot be played back on another machine, used perhaps in the classroom next door. The producers of pre-recorded *materials* must also face, and cope with, the many types of video players."

Under the title of "Reaching and Teaching the Vid Generation," Professor Robert Heinich of the Education Dept., Indiana University, and outgoing president of the Association for Educational Communication and Technology, presented a strong case for the need of educational institutions to change. This, in view of the newly developing mass media video techniques, if they are to continue to serve the students effectively.

Speaking on corporate video, Mr. Wallace C. Henry, Director of Communications for the Pepsi-Cola Co., discussed "Bigger Payoffs in Management Communication." He indicated the need for corporate users of the medium to analyze and understand the various audiences to whom they are addressing themselves within the organization and to produce their software accordingly, to make sure that they become more concerned with the kind of communicating job they are doing.

The consumer video field was discussed by Mr. Aaron Neretin, editor and publisher of *Merchandising Week* under the heading of "Tapping the Multi Billion Dollar Market—When?" He suggested that the figure 54 billion dollars, "the sum total of gross sales volume over the past 25 years of television product—both black and white and color (would be) dwarfed by the dollar values that all forms of videorecording and playback equipment will bring into the retailers treasury in a much shorter space of time than a quarter century."

He continued to describe the consumer market as the greatest potential for the video cassette industry and concluded with: "In our minds we must eliminate the *when* and substitute 1972 and 1973 as the realistic periods for positive involvement in consumer videorecording."

At the closing luncheon, Mr. William D. Littleford, president of the Billboard Group, talked on the subject "Separating the Possible from the Propaganda." Part of his remarks dealt with the future growth of the video cassette market.

"I ask you—if in one short year, we have seen the new media become economically proactical in the institutional and corporate markets with expansion dependent on literally tens of thousands of decision-makers, how fast will we move along when multiple options of programming become available to just a few thousand television and catv decision-makers? Is it not likely that within one more year the new media—new packaged programming—will be rapidly penetrating existing tv, and helping expand the potential of catv? And will not the whole new format for selective programming be taking shape? Whether over the air, through cable, or by purchase and rental by the consumer, we think selective programming in the home will be making meaningful advances by next year this time.

"We see a parallel between the rebirth and development of recorded sound in the Thirties . . . beginning with the juke box and skyrocketing through the past four decades with hardly an interruption despite the introduction of television. It was the public's all-consuming desire for the music you want when you want it! Nothing could stop it! High fidelity music, the lp record, stereo, new rock and easy listening sounds, and now quad sound, were the result of the basic demand for wider selectivity in music, not the cause of it.

"This is why we believe nothing can stop the tv cartridge movement. Increasingly profitable and widespread usage in the corporate and

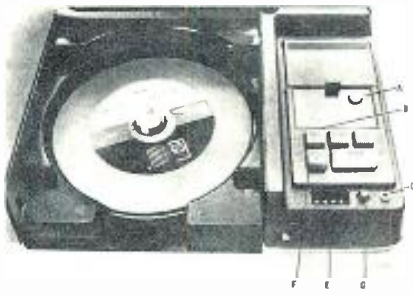

The MGA division of Mitsubishi International Corp. presented its EVR unit. The controls called out are: A—power; B—motion controls; C—mic jack for live commentary during play (not record); D—reset button for counter; E—counter; F—still and stop controls.

educational markets, followed by a much more rapid availability and adoption by tv and catv of packaged and on-location programing, are the preliminaries to bring about an era of selective video programing—the packaged programing you want when and where you want it.”

Mr. Littlefore invited all to attend VidExpo 73 which would take place next fall. For more information we suggest you write Mr. Stephen Traiman, Director of Public Relations, Billboard Publications, Inc., 165 W. 46th St., N.Y. 10036. We should like to extend our thanks to Mr. Traiman for his invitations and courtesies extended to us. Recordings on cassettes were also made of the talks and further information on them is also available from Mr. Traiman.

Approximately 1,000 visitors attended the conference and, in addition to the addresses and panel discussions, were able to visit the booths of about two dozen of the leading companies dealing in the hardware, software and services associated with the video cassette field. Once again, I will indicate briefly some of the exhibitors and their displays, but not because I approve or recommend them over any other. This is simply to indicate the scope of the material presented with some descriptive notes.

Akai showed its line of 1/4-inch video recorders, and the recently introduced color camera said to be the lightest on the market at 5 3/4 lbs., and the new 1/4-inch color tape deck which can handle up to 10 1/2-inch reels for a total program time of 80 minutes.

Concord Communications showed, among other items, its new color 3/4-inch cassette recorder and player, and a small but capable tv production console with switching and effects features. The color tape units contain features which are unique in an elevator-type lifting and lowering motion for the cassette holder operated elec-

trically by pushing a button (interlocked with other functions to prevent accidental operation of other buttons during raising or lowering of the cassette), and a remote control capability. Development is presently in progress on still other features which will become available. Delivery on the tape units is scheduled for September. The formats of the recorder and player are a rotary 2-head helical scan U-system with a 1 volt p-p output into 75 ohms and an r.f. output to channel 5 or 6. Resolution for b & w is greater than 300 lines, color greater than 240 lines. Video signal system is EIA standard 525 lines.

The MGA Division of Mitsubishi displayed its EVR player for the first time in this country. The unit is fully compatible with world-wide standards for the 50- and 60-Hz. unified program, has solenoid operation of push-button controlled functions, features a stop-action on a single frame and a control knob which permits single frame movement of the images, and an auto-play switch which rewinds the film automatically or can be set for continuous program replay.

Motorola had on display a custom console version of their EVR player and presented color cassettes with examples of recent programs in law enforcement and security.

MPO demonstrated its cartridge-operated super-8 rear-screen projector units in console and portable models. A new smaller and lighter portable unit was also shown which is very compact in carrying size (14 1/2 x 10 1/2 x 5 1/2) but which gives a picture measuring 11 3/4 x 8 3/4.

Sony had on exhibit its 3/4-inch U-Matic units and offered a complete catalogue with about 1,000 listings of available pre-recorded material in entertainment, training, instruction, and information categories that were for lease or sale through the listed program distributors.

Panasonic showed both its 3/4-inch U-standard units and their 1/2-inch EIAJ-standard equipment, in recorders and players.

Retention Communication Systems presented its variable speed super-8 projection systems.

Sonocraft had on display a 3/4-inch 3M/Wollensak videocassette player and recorder/player, a Philips color camera, an Instant Video Graphics illustrator, and other tv production and distribution equipment.

Tektronix showed various items of its line of monitoring and analyzing equipment, including special color monitors, a waveform monitor and a color vectorscope.

Vior Corp. displayed a large screen monochrome video projector which

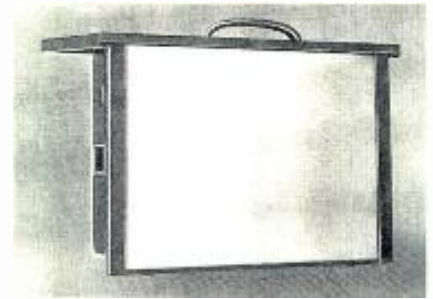

This is MPO's compact super-8 rear-projection unit. It folds to easily-handled suitcase dimensions.

was used during the talks to present large images of pre-recorded material brought to the conference by the speakers to illustrate their remarks.

The entire list of displays would be too lengthy here, but I hope excerpts of the talks and highlights of the exhibits whetted your interest for further information about either VidExpo 72 or the material presented and displayed during the convention.

With a quick look backward, there is one more conference that might be mentioned in the near future, and a look ahead to tell you the 112th SMPTE technical conference is scheduled for October 22-27 at the Century Plaza Hotel, Los Angeles. Don't just sit there. ■

db binders only \$4.95 postpaid

Heavy-weight binders are now available to hold the thirteen issues of Volumes 1 and 2. Rich brown leather-grained virgin vinyl, with our name printed in black on the spine and front cover, is electronically sealed over rigid board to give your volumes of db lasting protection. Keep your copies preserved in perfect condition, protected from dust and damage.

Please send me _____ copies of the db Magazine binder. My check for \$_____ is enclosed (sorry, no c.o.d.).

Name _____

Address _____

number and street

city _____ state _____ zip _____

(New York State residents please add 6% sales tax).

Mail to: db the Sound Engineering Magazine, 980 Old Country Road, Plainview, N.Y. 11803.



As a service to our readers we are pleased to offer books from prominent technical publishers. All prices listed are the publishers' net. Shipping charges are included.

To order use the coupon at the bottom of the page. Indicate quantity on the special instructions line

If more than one copy of a title is wanted. Full payment must accompany your order. We cannot ship c.o.d. Checks or money orders should be made payable to Sagamore Publishing Company, Inc. Because of the time required to process orders, allow several weeks for the receipt of books.

BOOKCASE

20. The Audio Cyclopedia (2nd ed.). *Dr. Howard M. Tremaine.* New and updated, here is the complete audio reference library in a single volume. It provides the most comprehensive information on every aspect of the audio art. This new edition includes the latest audio developments including the most recent solid-state systems and integrated circuits. It covers all subjects in the fields of acoustics, recording, and reproduction with more than 3400 related topics. Each topic can be instantly located by a unique index and reference system. More than 1600 illustrations and schematics help make complicated topics masterpieces of clarity. 1760 pages; 6½ x 9½ hardbound. **\$29.95**

1. The Technique of the Sound Studio. *Alec Nisbett.* This is a handbook on radio and recording techniques, but the principles described are equally applicable to film and television sound. 264 pages; 60 diagrams; glossary; indexed; 5½ x 8½; clothbound. **\$14.50**

7. Acoustical Tests and Measurements. *Don Davis.* Provides solid understanding of the entire subject of acoustical measurements; based on actual field test work, using commercial equipment. 192 pages; 5½ x 8½; hardbound. **\$6.95**

8. Handbook of Electronic Tables & Formulas, (3rd edition). A one-stop source for all charts, tables, formulas, laws, symbols, and standards used in electronics. Includes an 8-page, full-color fold-out chart showing latest FCC allocations for the entire frequency spectrum. 232 pages; 5½ x 8½; hardbound. **\$5.50**

24. Basic Electronic Instrument Handbook. *Edited by Clyde F. Coombs, Jr. Hewlett-Packard Co.* A basic reference background for all instruments. Offers saving in time and effort by having complete information in one volume on how to get the most benefit from available devices, how to buy the best instrument for specific needs. Reduces chances of costly errors. Ideal reference book, it is an excellent source for the beginner, technician, the non-electrical engineering man, or general non-engineering scientific and technical personnel. 800 pages. Hardbound. **\$28.50**

25. Operational Amplifiers-Design and Applications. *Burr-Brown Research Corp.* A comprehensive new work devoted entirely to every aspect of selection, use, and design of op amps—from basic theory to specific applications. Circuit design techniques including i.c. op amps. Applications cover linear and non-linear circuits, A/D conversion techniques, active filters, signal generation, modulation and demodulation. Complete test circuits and methods. 474 pages. **\$15.00**

26. The Design of Digital Systems. *John B. Peatman.* Textbook for students desiring to develop a creative approach design capability through digital systems approach. Answers these questions: Under what circumstances it is desirable to implement a system digitally? What are some of the components available for implementing the system? How do we go about designing it? 448 pages. **\$15.50**

31. Solid-State Electronics. *Hibberd.* A Basic Course for Engineers and Technicians. An extremely practical reference book for anyone who wants to acquire a good but general understanding of semiconductor principles. Features questions and answers, problems to solve. 169 pp. **\$9.95**

32. Circuit Design for Audio, AM/FM, and TV. *Texas Instruments.* Texas Instruments Electronics Series. Discusses the latest advances in design and application which represent the results of several years research and development by TI communications applications engineers. Emphasizes time- and cost-saving procedures. 1967. 352 pp. **\$14.50**

35. An Alphabetical Guide to Motion Picture, Audio, Television, and Videotape Productions. *Levitan.* This all-inclusive, authoritative, and profusely illustrated encyclopedia is a practical source of information about techniques of all kinds used for making and processing film and TV presentations. Gives full technical information on materials and equipment, processes and techniques, lighting, color balance, special effects, animation procedures, lenses and filters, high-speed photography, etc. 1970. 480 pp. **\$24.50**

40. Radio Transmitters. *Gray and Graham.* Provides, in a logical, easy-to-understand manner, a working knowledge of radio transmitters for quick solution of problems in operation and maintenance. 1961. 462 pp. **\$16.00**

23. Wide Screen Cinema & Stereophonic Sound. *M.Z. Wyszotzky.* First published in USSR in 1965 this excellent English translation covers wide gauge films, panoramic films, circular panoramic cinematography; technical fundamentals of stereo sound recording for film, as well as details of the Soviet systems now in use. 284 pages. **\$15.00**

33. Noise Reduction. *Beranek.* Designed for the engineer with no special training in acoustics, this practical text on noise control treats the nature of sound and its measurement, fundamentals of noise control, criteria, and case histories. Covers advanced topics in the field. 1960. 752 pp. **\$19.50**

27. Noise & Vibration Control. *Edit. by Leo L. Beranek.* Practical design and regulatory information; formulas, choice of materials and structures, city codes and hearing protection; indispensable for design engineers, public officials who prepare regulations for noise control, safety and environmental engineers involved in noise and vibration controls. Covers data analysis, transmission of sound, psychophysiological design criteria, hearing damage risk, etc. Wealth of detail, comprehensive index and concise appendices. 650 pages. **\$29.50**

28. Environmental Acoustics. *Leslie L. Doelle.* Applied acoustics for those in environmental noise control who lack specialized acoustical training. Basic information in comprehensible and practical form for solving straightforward problems. Explains fundamental concepts; pure theory minimized. Practical applications stressed, acoustical properties of materials and construction listed, actual installations with photos and drawings. Appendixes illustrate details of 53 wall types and 32 floor plans and other useful data. 246 pgs. **\$18.50**

21. Acoustics—Room Design and Noise Control. *Michael Rettinger.* 1968. The enormous problems and hazards presented by noise are dealt within an orderly and practical manner. With many charts, graphs, and practical examples, the text covers the physics of sound, room acoustics, and design, noise and noise reduction. 392 pages. **\$17.50**

22. Acoustics of Studios and Auditoria. *V.S. Mankovsky.* Basic theory plus a mass of design data covers the field with special reference to studios and places of public performance. For acoustical designers and specialists in sound transmission in cinema and broadcasting. Features exhaustive treatment of studio acoustics by the statistical, geometric and wave methods in parallel. 416 pgs. **\$15.00**

Sagamore Publishing Company, Inc.
980 Old Country Road,
Plainview, N.Y. 11803

Please send me the books I have circled below. My full remittance in the amount of \$_____ is enclosed. N.Y. State residents add 7% sales tax.

1	2	3	4	5	6	7	8	9	10	11
12	13	14	15	16	17	18	19	20		
21	22	23	24	25	26	27	28	29		
30	31	32	33	34	35	36	37	38		
39	40									

Name _____

Address _____

City _____

State _____ Zip _____

Special Instructions _____

Canada and foreign: Add \$1.00 per book

CLASSIFIED

FOR SALE

FOR SALE: Crown CX-822 tape recorder, accessories. (215) 667-3048.

SCULLY 284-8 RECORDER. Mint condition very low hours with sync master. \$8,000 fob Omaha. Contact Grant Schainost, Sound Recorders, (402) 553-1164.

AMERICA'S LARGEST SELECTION of new and used broadcast and recording equipment! Latest bulletins available. **The Maze Corporation, P.O. Box 6636, Birmingham, Ala. 35210.**

WHATEVER YOUR EQUIPMENT NEEDS—new or used—check us first. Trade your used equipment for new. Write for our complete listings. **Broadcast Equipment & Supply Co., Box 3141, Bristol, Tenn. 37620.**

SOLID-STATE AUDIO MODULES. Console kits, power amplifier kits, power supplies. Octal plug-ins—mic, eq, line, disc, tape play, tape record, amplifiers. Audio and tape bias oscillators. Over 50 audio products, send for free catalog and applications. **Opamp Labs. Inc., 172 So. Alta Vista Blvd., Los Angeles, Ca. 90036. (213) 934-3566.**

HAECO announces complete repair service and overhaul for all Westrex cutterheads. Conversions of 3D-II and older models to higher performance standards and reliability. Helium cooling systems and hi-temp coils can protect your investment. Repair insurance program available. Rapid service. Lower cost. **HAECO, 14110 Aetna, Van Nuys, California 91401.**

SCULLY TAPE RECORDERS—one to twenty-four track and model 270 auto players, many models in stock for immediate delivery. SCULLY LATHES—Previously owned and rebuilt. Variable or automatic pitch. Complete cutting systems with Westrex heads. MIXING CONSOLES—Custom designed using Weigand Audio Lab modules. From \$7,000.00. **Weigand Audio Laboratories, R.D. 3, Middleburg, Pa. 17842. Phone (717) 837-1444.**

IN THE NORTHEAST it's Audiotechniques for MCI 8-16-24 track recorders and mixing consoles. The performance is superb, the price is right and the delivery is fast! What else do you want? You're right... service! That's Bob Berliner's job, and there's none better. **Audiotechniques, 121 Hamilton Avenue, Stamford, Conn. 06902. (203) 359-2312.**

COMPLETE DISC CUTTING SYSTEM. Eq. filter, limiter, amps, 605B speaker, jack bays, Gramplan head and amp in rack and Ampex 350-1C: \$3300.00. Plastic tape hold downs: \$15.00. **Washburn Co., 6114 Santa Monica Blvd., Hollywood, Ca. 90038.**

AMPEX 602 TRANSPORT with Ampex AG-600 series ¼-track head assembly. Like new. \$512 value for \$230. More items—send for list. **RDD, 1807 Elmcrest, Arlington, Texas 76012.**

AUDIO DESIGNS CONSOLE—sixteen input, 8/16 output. Audex program and echo bus assignment. Quad monitoring both studio and control room with Audex tape track to speaker assignment. Quad outputs. Sixteen-track monitor mix. Four equalized echo busses. Two cue busses. \$16,000. **Sound 80, (612) 721-6341.**

TELETRONIX LIMITER, Pultec's Fairchild 523-J1 lathe Neumann cutter, Mac 200 watt. Best offer. **Bradley Recording, 531 N. Howard Street, Baltimore, Md. 21201. (301) 727-0950.**

EXCLUSIVELY IN USA "Satin" moving coil cartridges. Impedance matches magnetic input. M14LE (elliptical) \$99.95, M14LX (Shibata) \$129.95. Send check to **Michael-Scott Enterprises, Room 24, 6056 West Broadway, Minneapolis, Minn. 55422.**

AUDIO EQUIPMENT, new and used. Custom consoles built to your specifications using the components of your choice. Whether you're building a new studio or remodeling your present one, check us first for a package price. **Amboy Audio Associates, 236 Walnut Street, South Amboy, N.J. 08879. (201) 721-5121.**

SCULLY 284-8, excellent condition, with sync master. Console 20 by 4 custom built using Electrodyne 710LC modules; three complimiters; monitor panel, (stereo mix with separate cue mix). Call or write **Synchron Sound Studios, Inc., 10 George Street, Wallingford, Conn. 06492. (203) 269-4465.**

IN THE NORTHEAST it's Audiotechniques for STANDARD TAPE LABORATORY test tapes. We think they're the most dependable, accurate reference tapes available. Call Ham Brosious or Bob Berliner and find out why. **Audiotechniques, 121 Hamilton Avenue, Stamford, Conn. 06902. Phone (203) 359-2312.**

LIKE NEW AMPEX ½-inch, 4-track heads and assembly (erase, record, playback). 300 series. Best offer. **Continental Recordings, 12 Irving Square, Framingham, Mass. 01701. (617) 879-2430.**

CLOVER SYSTEMS announces the introduction of a complete line of unique stock and custom consoles. Write or call for information regarding our complete line of hardware and services, including complete turn-key studio installations. **Clover Systems, 12970 Branford St., Arleta, Ca. 91331. (213) 768-2100.**

MUST SELL: Langevin 25 input (switchable to 75 input) four output board. Sliders, complete equalization on each input—ideal for remote truck. New cost \$17,000, sacrifice for \$13,000. Also stereo Dolby, UREI limiters, Fairchild stereo limiter, Fairchild reverb, McIntosh amplifiers, various microphones at reasonable prices. Also available, Scully 16 track with sync, digital counter; Scully two-track; Ampex full track AG-600. Call **(206) 392-2493 after six p.m. Pacific time.**

NEW YORK'S LEADING supplier of professional audio/video equipment and hi-fi stereo components. All major brands in stock. Call for quote—sales—service—leasing—trade-ins. **Martin Audio, 320 West 36th Street, New York, N.Y. 10036. Telephone: (212) 265-6400.**

AMPEX 601 full track 7½ in./sec. In immaculate condition. Totally operating. Heads moderately worn. \$100.00 Orban/Parasound Reverberation model 105C. In perfect condition. One year old. Built-in attack limiter. \$250.00. **Different Fur Studios, 3470 19th Street, San Francisco, Ca. 94110. (415) 864-1967.**

SPECIAL—NEW FIDELIPAC NAB cartridges, 10 secs to 6 minutes. Only \$1.25 each. Minimum quantity 50 carts. Specify lengths when ordering. **Gately Electronics, 57 W. Hillcrest Avenue, Havertown, Pa. 19083.**

FM TUNER/RECEIVER alignment. Free checkout for distortion, frequency response, separation (see June-July 1970 issues of Audio). Complete FM tuner alignment \$20 plus parts. One year guarantee. **FOB A. L. Boynton, 369 Aklan Ct., San Jose, Ca. 95119.**

ONE STOP FOR ALL your professional audio requirements. Bottom line oriented. **F.T.C. Brewer Company, P.O. Box 8057, Pensacola, Florida 32505.**

EMPLOYMENT

PROFESSIONAL RECORDING PERSONNEL SPECIALISTS. A service for employers and job seekers. Call today! **Smith's Personnel Service, 1457 Broadway, N.Y.C. 10036. Alayne Spertell 212 Wi 7-3806.**



CATV—MATV PRODUCTS

- CONNECTORS
- WALLPLATES
- SPLITTERS
- AMPLIFIERS

AVA ELECTRONICS CORP.
416 LONG LANE, UPPER DARBY, PA. 19082
215—MA 1 9100

PEOPLE, PLACES, HAPPENINGS

● In a major expansion move, **Sansui Electronics Corporation** has moved into its new combined American headquarters and East Coast distribution facility. The new plant is located at 55-11 Queens Boulevard, Woodside, N.Y. 11377. The new headquarters has a total of 30,000 square feet of floor space, of which 6000 is devoted to offices. Warehousing, shipping, and distribution facilities are contained in the building, as are demonstration rooms, conference rooms, and a product showroom.

● **Budd D. Johnson** has been named to the post of sales manager for **Tascam Corporation**, according to **Arne Berg**, executive vice president. He comes to Tascam from a position as an executive with an ad agency. He brings additional talents as a musician with many performance credits in major cities and capabilities as a composer to the position.

● **Sony Corporation of America** has a new president. He is **Harvey L. Schein**. He also becomes chief executive officer and a member of the board of directors. He succeeds **Kazuo Iwama** who now becomes chairman of the Board. Mr. Schein comes to Sony from fourteen years with the **Columbia Broadcasting System, Inc.**, where he was president of the CBS/Columbia Group and a vice president of the corporation.

● An announcement from **Custom Fidelity** tells of the formation of a department to market recorders designed and manufactured by **PAK Associates**. This department, named the Studio Systems Department is headed by **William F. "Bill" Jones**. The new department is part of the Professional Audio Sales division of the company. Bill Jones has had many years of experience in the marketing of sophisticated recording studio components and systems.

● Word from the **URC Companies** is that **M. T. "Bill" Putnam**, president of the firm is recovering at home from open heart surgery to relieve an Angina Pectoris condition. The operation was performed on August 16th and according to the team of physicians. Bill has enjoyed a record recovery from the difficult procedure and they are reported pleased with his condition and the results of the arterial repairs.

We certainly are delighted to report this and join many that know him in wishing Bill the speediest recovery and return to duty. During his absence, the firm is being run by **D. F. "Bud" Morris**.

● The **National Council of Acoustical Consultants** has elected the following officers and directors: as president, **Robert Lindahl** of Trenton, Michigan; vice president is **Conrad J. Hemond, Jr.** of East Granby, Connecticut. Directors elected are **Ronald J. Carr**, of Hawthorne, Victoria, Australia; **David McCandless** of Austin, Texas; and **Kenward S. Oliphant** of San Francisco, Ca. **O. L. Angevine, Jr.** of East Aurora, N.Y. was reappointed secretary-treasurer.

● Two announcements from **Audio Designs**: a new building and a new marketing manager.

The building is approximately three times the size of the former plant and is a short distance from the former plant, located in suburban Detroit. The new address is 16005 Sturgeon, Roseville, Michigan 48066. All company activities will be housed in the new structure.

The new marketing manager is **James S. Meek** who comes to Audio Designs from **Telemation, Inc.** He will be responsible for all marketing activities of the company including field sales, advertising, and sales promotion. He brings to the company a background in business, broadcasting, and marketing.

● In the first contested election of the **Institute of High Fidelity**, **Herbert Horowitz** has been elected president. Other officers of the organization elected are v.p., **Bernie Mitchell**; treasurer, **Walter Stanton**; secretary, **Bill Kasuga**. The balance of the board includes **Arthur Gasman**, **Jerry Kaplan** (newly elected directors)—and three directors with one year remaining to their term. **Stan Grossman**, **Don Palmquist**, and **Hiroshi Tada**.

● **Marvin R. Headrick** has been appointed to the position of western regional sales manager for **McMartin Industries, Inc.** He brings to the firm extensive sales and marketing experience with **Langevin**, **Stern Company**, and the **American Broadcasting Co.** The present McMartin sales rep organizations covering the Rocky Mountain, West Coast, and Western Canada areas, as well as Hawaii and Alaska, will operate under Mr. Headrick's direction.

It is with deep regret that we report the death of James J. Noble, senior vice president of the Altec Division of the Altec Corporation. He was 53 at the time and death followed a long illness. Funeral services were held on August 29th.

Mr. Noble spent most of his business career with Altec, beginning in 1947 when he went to work in the manufacturing department. In 1960 he was appointed chief engineer, which was the beginning of a series of promotions that saw him hold titles of director of engineering, vice president of engineering, senior vice president. In 1970 he was named a Fellow of the AES "for his contribution as designer and director of engineering for a broad line of audio electronic equipment."

StopClock

A New, Accurate, Digital Timing Instrument for Recording Studios, Broadcasters, and Other Demanding Applications

Timekeeper is proud to introduce a new inexpensive *Electronic StopClock*—a compact instrument featuring an easily-read visual display.

Only 5 1/8" wide x 3 1/4" high x 5 1/2" deep, it uses modern digital circuitry to provide accuracy of a very high order with exceptional long term stability. The large 3/8" high, seven-segment numerals can easily be read from a distance of more than 15 feet. Maximum count is one hour (59:59:9).

Three remote-mounted push buttons are used for manual control: START, STOP, and RESET. These buttons may be placed in a console, operating desk or any convenient location. The clock may be remotely located in the equipment, or on a desk or table. (A mounting flange is provided.)

Operation is similar to any conventional stopwatch. The green button starts the clock; the red button stops it. The black button resets it to zero. These may be depressed in any order, or all at once, without damage to the clock. If it is desired to start the clock by releasing a button rather than depressing one, the green and black button are pressed simultaneously. When the black button is released, the clock will start automatically.

The accessory plug on the rear panel may be used for all remote operations. All BCD information is available at this plug for accessory units such as digital printers, slave units, etc.

The Model T-1 is supplied for 120 volt 60 Hz operation, in an attractive simulated walnut grained enclosure with a red lucite face. However, 120-volt 50 Hz operation is available at no extra charge if so specified at the time you place your order.

The Model T-1 is priced at \$185.00. As with all Timekeeper products, it is fully guaranteed to meet with your complete satisfaction, or your money will be promptly refunded. It is guaranteed for one year against any defects in manufacturing.

The Timekeeper Electronic StopClock is a must. More than a high quality timer—it provides the added convenience of full visual display, high accuracy and stability plus operational flexibility. Order one soon. You will be delighted with it.

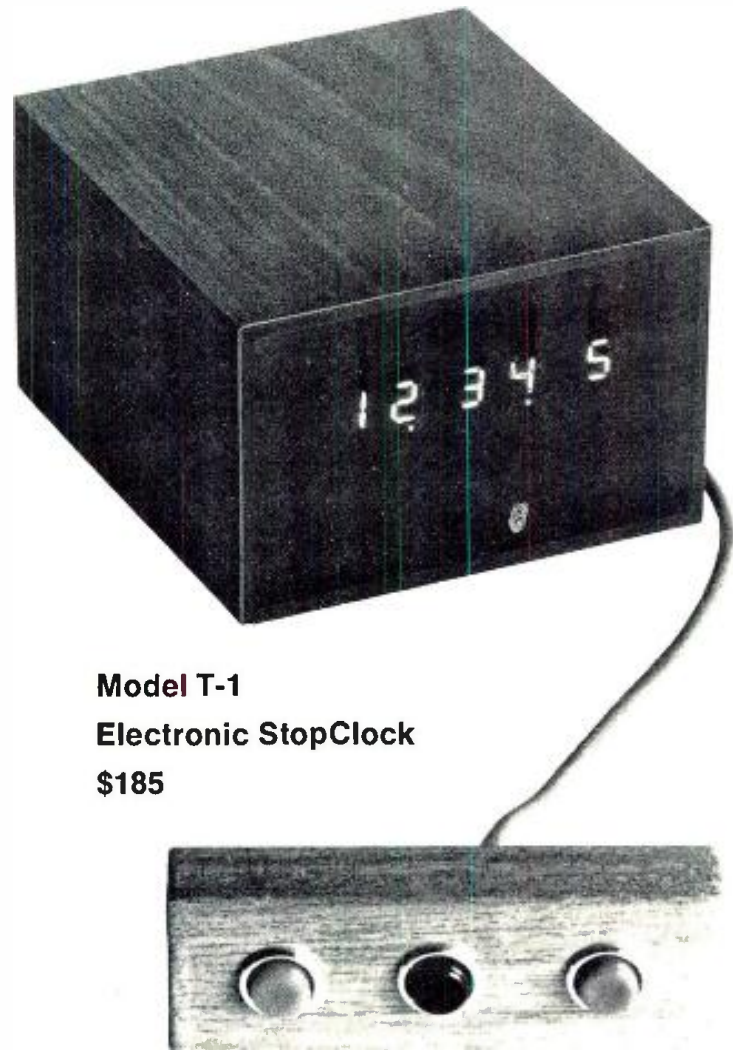

Model T-1
Electronic StopClock
\$185

TIMEKEEPER

P.O. Box 835, Great Neck, N.Y. 11021

Please send me _____ Model T-1 Timekeeper Electronic StopClock(s) at \$185.00. N.Y.S. residents add 7% sales tax. Add \$1.00 shipping per order. I enclose \$ _____

Name _____

Address _____

City _____

State _____ Zip _____

Built better. Performs longer. Costs less.

Wire windings are OUT, conductive plastic is IN for high performance audio controls. With its new Series 300 SLIDELINE™, Duncan Electronics replaces noisy, rough and "grainy" wire elements with smooth, noise-free RESOLON® conductive plastic which actually improves with use!

RESOLON elements and precious metal wipers used in all Series 300 controls bring consistent low-noise operation and superior performance to linear motion faders for broadcast and recording. And, the cost is less than many high grade wirewound controls of the past!

Series 300 is offered in 6 different stroke lengths and features longer life of 10 million traverses minimum, infinite resolution and linear, audio and constant impedance outputs for every audio need!

Dual channels can be contained in a standard single housing only $1\frac{3}{16}$ " wide — the most compact dual attenuator available to the industry. Two dual units can be coupled and driven by a common knob to create 4 channels for master controls or quadrasonics.

For complete specifications, call or write for our FREE brochure.

Duncan Series 300 A sound idea.

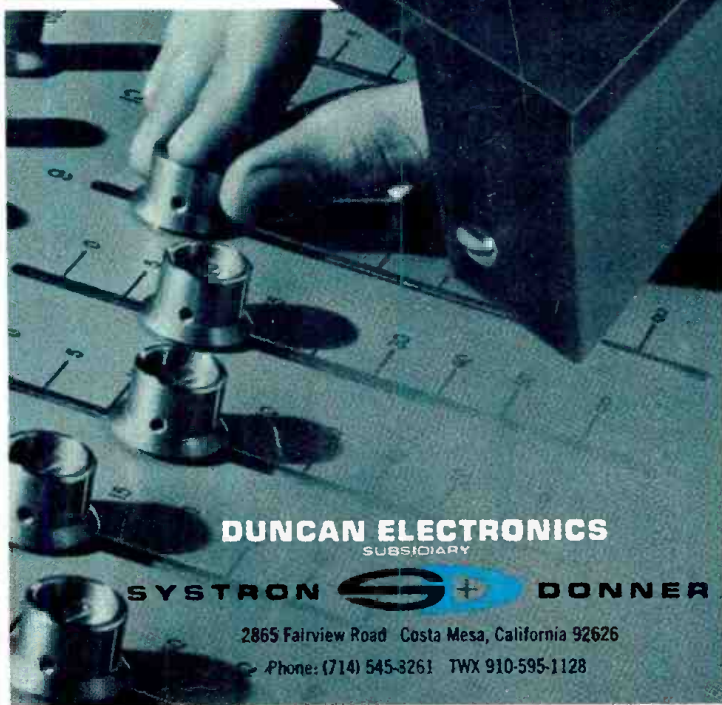

Series 220 Slideline™

Similar to our Series 200, but internal design and construction are totally new for vastly improved performance. Features the same Resolon element as the professional grade Series 300. This results in far lower noise, longer life (5 million strokes minimum), infinite resolution and smoother "feel."



DUNCAN ELECTRONICS
SUBSIDIARY

SYSTRON  **DONNER**

2865 Fairview Road Costa Mesa, California 92626

Phone: (714) 545-3261 TWX 910-595-1128