

ISSN 0011-7145

# enr

THE SOUND ENGINEERING MAGAZINE  
MARCH 1974 \$1.00

ENR RADIO  
205 COMMUNICATIONS "BIDG  
N.G. 50  
PO BOX 97711  
SEATTLE WA 98105





# We repeat.

Being the best in duplicating equipment isn't easy.

That's why we at Electro Sound design our professional tape duplicating system to be both durable and versatile. Long lasting hardware. Mono through eight channels; reel, cassette and cartridge formats. And Quad, too!

Sure we use state-of-the-art techniques. Our transports are known for their round-the-clock ruggedness and our solid-state electronics for their sophistication.

A unique a.c. eddy current clutch constant tension system, electronic cue tone injector and a 2,000' capacity vertical loop bin that guards against tape edge curl are examples of our skills. But so what?

It's the ability to efficiently produce a finished tape of unquestioned high quality that pays off in operating profits for our customers. Plug-in heads with integral scrape flutter idlers let operators change master or slave tape width or formats in seconds. Speeds of 240, 120 or 60 ips means production flexibility. Endless loop or auto rewind handles any duplicating job. And nobody has more practical experience with ferrite duplicating heads than Electro Sound.

But that's not all. We are the only single source manufacturer of duplicators, loading racks, quality control reproducers, mastering recorders, cartridge and cassette winders and splicers—all that's required for a fully operational plant. And we provide on-site engineers for equipment installation and employee training. That's service.

Whether you duplicate retail music, broadcast syndications or "spoken word" cassettes, Electro Sound has a system for you. After all, the giants who pioneered the industry, as well as those just joining it, are using Electro Sound systems in 30 countries.

We repeat. Being the best in duplicating equipment isn't easy.

Circle 10 on Reader Service Card

## ELECTRO SOUND

725 KIFER ROAD, SUNNYVALE, CA 94086  
(408) 245-6600 TELEX: 346324 LECTROSOUND SUVL

Exclusive International  
Distributor  
Audiomatic Corporation  
New York and Paris

## COMING NEXT MONTH

• Oscar Burke concludes his penetrating study of the decibel. These two parts combine to make the reader authoritative on the deepest usage of the decibel as an audio tool.

Don Davis returns to our pages with a two-parter beginning in April called **IMPEDANCE MATCHING FOR THE SOUND ENGINEER**. There is some math involved, of course, but the usual Don Davis lucid explanation of the subject matter can be expected.

Early May (the 7th through the 10th) is Los Angeles AES Convention time, so the April issue is the pre-show issue and will have the usual schedule of events, list of papers to be given, and exhibition map.

And there will be our regular columnists: Norman H. Crowhurst, Martin Dickstein, and John Woram. Coming in *db*, **The Sound Engineering Magazine**.

## ABOUT THE COVER

• Our cover is a reproduction of an Egyptian arched harp, lute, double oboe, and lyre. This is from a tomb painting found in Veset (Thebes) and has been dated as having been painted circa 1420-1411 B.C.



THE SOUND ENGINEERING MAGAZINE

MARCH 1974 VOLUME 5, NUMBER 3

20	AN INTEGRATED CIRCUIT HEADPHONE AMPLIFIER Douglas C. Myers
24	THE DECIBEL: BASICS, part 1 A. Oscar Burke
30	db VISITS dbx
2	LETTERS
omitted this month	THE SYNC TRACK John Woram
4	THEORY AND PRACTICE Norman H. Crowhurst
12	SOUND WITH IMAGES Martin Dickstein
15	NEW PRODUCTS AND SERVICES
34	CLASSIFIED
36	PEOPLE, PLACES, HAPPENINGS

**db is listed in Current Contents: Engineering and Technology.**

<b>Robert Bach</b> PUBLISHER	<b>Larry Zide</b> EDITOR
<b>Bob Laurie</b> ART DIRECTOR	<b>John Woram</b> ASSOCIATE EDITOR
<b>A. F. Gordon</b> CIRCULATION MANAGER	<b>Hazel Krantz</b> COPY EDITOR
<b>Eloise Beach</b> ASST. CIRCULATION MGR.	<b>Richard L. Lerner</b> ASSISTANT EDITOR
GRAPHICS <b>Crescent Art Service</b>	

db, the Sound Engineering Magazine is published monthly by Sagamore Publishing Company, Inc. Entire contents copyright © 1974 by Sagamore Publishing Co., Inc., 980 Old Country Road, Plainview, L.I., N.Y. 11803. Telephone (516) 433 6530. db is published for those individuals and firms in professional audio-recording, broadcast, audio-visual, sound reinforcement, consultants, video recording, film sound, etc. Application should be made on the subscription form in the rear of each issue. Subscriptions are \$6.00 per year (\$12.00 per year outside U. S. Possessions, Canada, and Mexico) in U. S. funds. Single copies are \$1.00 each. Controlled Circulation postage paid at Harrisburg, Pa. 17105. Editorial, Publishing, and Sales Offices: 980 Old Country Road, Plainview, New York 11803. Postmaster: Form 3579 should be sent to above address.



Model RE51 \$83.70 suggested net.

## Never be "off-mike"

**again!** Now a microphone you wear, just like the astronauts, and major TV sports commentators. This 1/2-ounce dynamic close-talking microphone fits on its own headband, your eyeglasses, or headphones. The adjustable pickup tube stays at your mouth to provide constant volume and maximum noise cancellation.

With response from 80 to 10,000 Hz., it mixes perfectly with all other E-V broadcast models. A transistorized preamp (may be worn on the belt) includes a push-to-mute "cough" switch, On-Off switch, battery test light, and standard cable connector. Balanced Lo-Z output adjusts to maximum of -56 dB to match any console.

The new E-V RE51... that recognizes that you may have something better to do than hold a microphone.

**Electro-Voice®**

ELECTRO-VOICE, INC., Dept. 342BD  
686 Cecil St., Buchanan, Michigan 49107

a **Gulton**  
COMPANY

Circle 15 on Reader Service Card

## letters

The Editor:

The January issue of **db** contains an article entitled Low Cost Four Channel Remote Box. The unit is built around an AA-300 printed-circuit amplifier.

A check with the manufacturer showed that the AA-300 is out of production and no longer available anywhere.

However, the AA-100 is available. This unit has slightly less gain, a higher input impedance, and an on-board gain pot. The response is 100 to 12 kHz, whereas the AA-300 went to 20 kHz.

The complete address of the manufacturer is:

RHA Audio Communications Corp.  
625 60th Street  
West New York, N.J. 07093

*James Murphy*  
Chief Engineer  
WAJR

*Morgantown, W. Va.*

## advertisers index

Ampex . . . . .	3
Auditronics . . . . .	23
Automated Processes . . . . .	9
Bose . . . . .	18
Burwen . . . . .	23
dbx . . . . .	5
Electro-Sound . . . . .	Cover 2
Electro-Voice . . . . .	2
Gately . . . . .	16
Gotham Audio . . . . .	4
Intn'l Tapetronics . . . . .	19
Lumiere . . . . .	14
MITS . . . . .	13
Miller-Stephenson . . . . .	29
Polyline . . . . .	12
Ramko . . . . .	6
ReVox . . . . .	7
Sagamore Publishing . . . . .	33
Scott Instrument . . . . .	12
Shure . . . . .	Cover 4
Standard Tape . . . . .	14
Tascam . . . . .	11, Cover 3
Telex . . . . .	8
Timekeeper . . . . .	Facing Page 1
UREI . . . . .	10
Woram Audio . . . . .	18

**db**

THE SOUND ENGINEERING MAGAZINE

### SALES OFFICES

**New York**  
980 Old Country Road  
Plainview, N.Y. 11803  
516-433-6530

**Dallas**  
Roy McDonald Associates, Inc.  
Stemmons Tower West  
Suite 714  
Dallas, Texas 75207  
214-637-2444

**Denver**  
Roy McDonald Associates, Inc.  
3540 South Poplar Street  
Denver, Colorado 80237  
303-758-3325

**Houston**  
Roy McDonald Associates, Inc.  
3130 Southwest Freeway  
Houston, Texas 77006  
713-529-6711

**Los Angeles**  
Roy McDonald Associates, Inc.  
500 S. Virgil  
Suite 360  
Los Angeles, California 90020  
213-381-6106

**Portland**  
Roy McDonald Associates, Inc.  
2035 S. W. 58th Avenue  
Portland, Oregon 97221  
503-292-8521

**San Francisco**  
Roy McDonald Associates, Inc.  
Baybridge Office Plaza, Suite 265  
5801 Christie Avenue  
Emeryville, California 94608  
415-653-2122

# Introducing the new "C." Our best AG-440 yet.

Introducing the Ampex AG-440C. Latest model in an unbroken line of the world's most respected professional audio recorders. From the company that produced the very first professional audio tape recorder and has always been the standard of excellence against which all others are measured.

Ever since we produced our first AG-440 unit, delighted users have been kind enough to share with us their ideas to make a great machine even better. It was user suggestions that helped us design the AG-440B, and it was user suggestions again that inspired the new AG-440C.

Users requested **improved tape handling**, so we installed sapphire tape guides for less skew, tighter phase stability, and improved high frequency/high amplitude performance.

Users requested **easier editing**, so we redesigned the transport to allow tape spilling without going through the tension arm.

Users requested **motion sensing**, to allow them freedom to push any transport command button at any time, without fear of breaking the tape or stripping a gear. We installed the extra circuits and controls to make this possible.

Users requested **automatic monitoring in Sel-Sync mode**, so we made the switchover from output to input channel automatic whenever the Sel-Sync command is "record."

Users requested **more linearity at the high end**, so we extended the high frequency response as far as we could. Now the AG-440C is the world's flattest machine—from 30 to 25,000 Hz.

Users requested **pushbutton record/playback selection** for each channel. The knobs are gone, the buttons are in their place. And you can read the indicators all the way across a studio.

Users requested **stationary capstan mode**. Now you can cue up for a fast start almost as well as with a disk turntable.

Users requested **detent channel setup** for quick, positive return to preset levels following calibration. We complied.

There are a lot more than the eight improvements we listed above, and a few of the new wrinkles came from our labs as the result of continuing research programs. The overall result is the very best professional tape recorder available for broadcast, production, mixdown, or general utility soundwork.

Learn all about the user-designed AG-440C.

Send for our free brochure titled **BY SPECIAL REQUEST.**

It'll make you want to join the worldwide club of satisfied Ampex user/designers. Write or call today.

**AMPEX**

Ampex Corporation  
Audio-Video Systems Division  
401 Broadway  
Redwood City, CA 94063  
(415) 367-2011

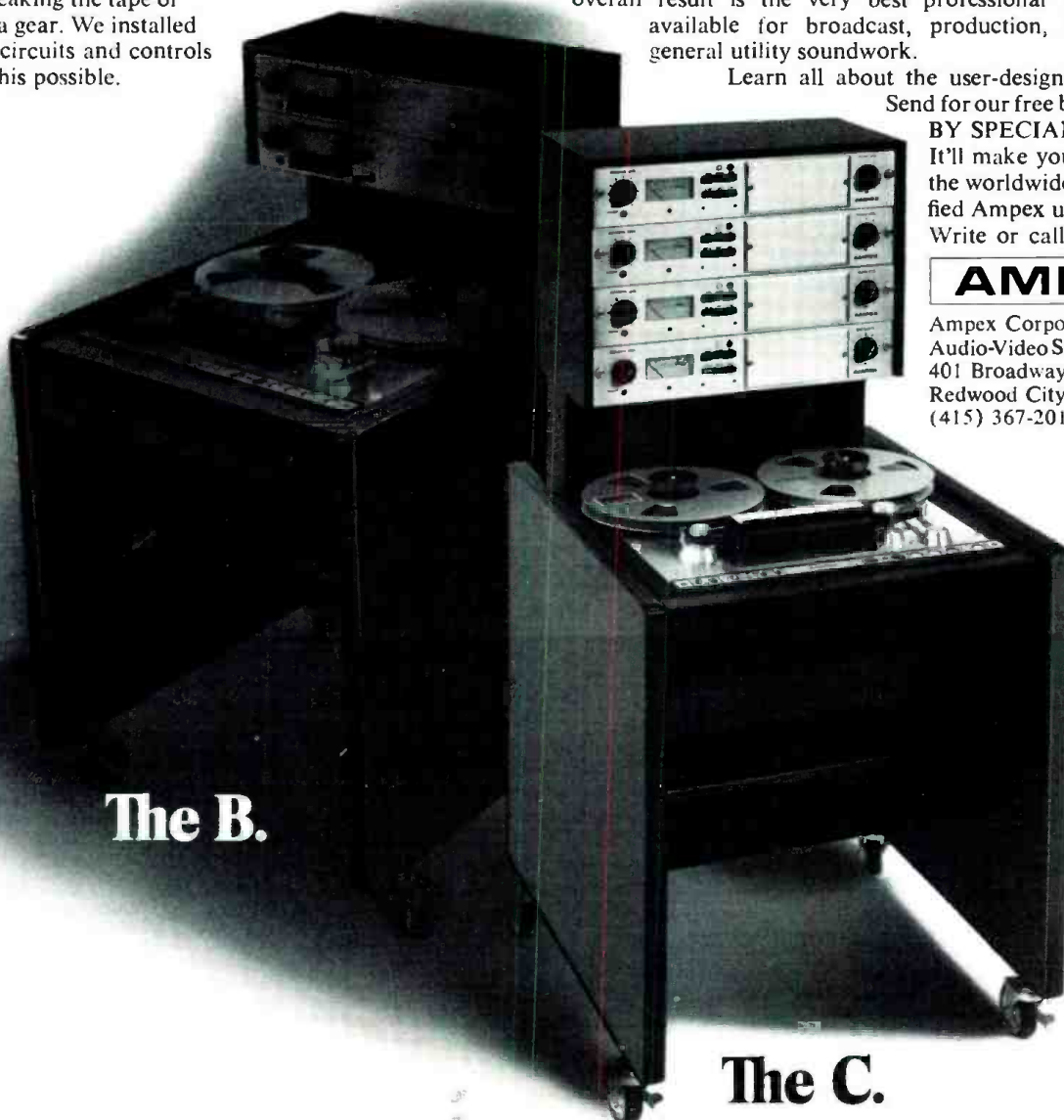

**The B.**

**The C.**

Circle 30 on Reader Service Card



## HOW NOT TO CHOOSE A MICROPHONE

As in any industry, there are fads of the moment, effects that are popular, recording techniques that create sounds rather than reproduce them. Yet, through 40 years of recording, there is one constant thread that runs through the fabric of our art, the NEUMANN condenser microphone. NEUMANN's preeminence in the field was established and is maintained not on the basis of its excellent specs but on its performance.

For broadcasters and recording studios throughout the world, both East and West, the NEUMANN microphone has been, and continues to be, the instrument of choice.

A professional musician can't pick out the Stradivarius from a catalogue of violin specs because there is no constellation of specifications that would pinpoint the Stradivarius. However, given no numbers at all but the date, and the name of Stradivarius, he could pretty well imagine its sound.

Similarly, from a catalogue of specifications on microphones, a recording engineer cannot hope to establish a correlation between the numbers given and the transducer's performance. The measurements used today are so gross that they fail to distinguish qualities that are essential in reproducing the sound of an instrument or an orchestra.

The neophyte, having little experience in studio work, relies heavily on specs as the drowning man relies on straws; and there's nothing that will save him from expensive mistakes except the realization that he can't choose microphones from catalogues or ads.

How, then, can he choose a microphone?

Very simply, ask the experts in the field.

Eli Passin, Vice Pres.,  
Gotham Audio Corporation

**GOTHAM**  
AUDIO CORPORATION

Headquarters: 741 Washington Street,  
New York, NY 10014 (212) 741-7411  
West Coast Sales Office: 1710 N. LaBrea Ave.,  
Hollywood, CA 90046 (213) 874-4444

Norman H. Crowhurst

## THEORY AND PRACTICE

● This is being written just before Christmas, although you will probably not be reading it until spring is making the countryside look young again. By one of those flukes that occasionally happen in publishing, the piece in the December issue was written only shortly before this one. As I sit down to write this, I have just been answering several suggestions about what I "ought" to do, for which I am always thankful.

This magazine is subtitled "The Sound Engineering Magazine," for which reason it seems that what I write here should in some way be connected with sound engineering, as well, as in some way being concerned with the relationship between theory and practice. However, as I have commented before, readers respond much more enthusiastically when I write about education.

Not that writing about education necessarily precludes it's also being about engineering. There are several interconnections that I have addressed from time to time. Most obvious, perhaps, is the fact that the audio man's art is used fairly extensively in education, and could usually be used more effectively, although the fact that it is not may be the fault of educators rather than engineers. So that facet gets discussed.

A little less obvious—but they keep intruding into the picture—are the engineering contradictions I receive, which would not arise if those who wrote them had been better educated to think things through for themselves. So I get sidetracked into the educational topic again, to comment on that.

Recently another observation triggered the same kind of association. Our family likes to watch the t.v. program, *The Price is Right*. In one of the little contests on that show the contestant has thirty seconds to guess the correct price, while the MC keeps saying "higher" or "lower," as relevant. Once in a while, a contestant does very well and wins the merchandise by following the MC's directions. More often contestants miss out by seeming to go crazy, guessing in very haphazard fashion, while the MC tries hard to help them by emphasizing *higher* or *lower*, as the case may be.

At first we attributed it to the excitement putting the contestant into a "flap." But as we studied their mistakes more carefully, it seems there is another explanation. These contestants have no idea of the significance of numbers over ten—that is, if they have two or three digits. Thus to them, \$299 sounds like more than \$300, because it has those 9s in it, and 9s are much bigger than zeroes, aren't they!

I sometimes make that kind of mistake in alphabetical indexing. For instance, the other day I was looking for a name that began with "Bur . . ." and found myself thinking I had gone beyond it when I came to a name beginning with "Bry . . ." It was the "y," but I did not notice the "r" sitting between. But I never make that kind of mistake with numbers. I would never make the mistake of thinking that 259 was bigger than 275, for example, which would be a corresponding kind of error.

# noise reduction takes a giant step forward with the dbx 216



With the dbx 216 professional tape noise reduction system, you get every one of these advantages over less advanced approaches:

- in excess of 30 dB of noise reduction which gives you an extra safety margin and lets you forget about noise build-up even in 24 channel applications
- 10 dB headroom improvement eliminates tape saturation or tape recorder overload worries
- 100 dB dynamic range makes level setting less critical
- no pilot tones or level matching required, just turn on and record
- true RMS level sensing guarantees perfect code/decode tracking and transient reproduction throughout the record and playback cycle
- simultaneous record and playback functions eliminate mode switching, remote control necessity, just spare two-channel module supplied with a 16-channel system reduces down-time to near zero
- complete cable assemblies with prewired mating XLR connectors make installation a simple 30-minute plug-in operation
- expandable modular design allows purchase of as few as four channels, with easy subsequent expansion to 8, 16, 24, or any number of channels
- typical 16-channel simultaneous record/playback noise reduction system with spare module and cables, ready to install costs \$8,200
- available from professional audio dealers or the factory

dbx, Incorporated, 296 Newton Street, Waltham  
Massachusetts 02154



# dbx

# Buy the best at any cost— even if it costs you less!

Broadcast and audio engineers around the nation have chosen Ramko products on performance specs alone. Then were pleasantly surprised at our low, low prices.

Compare Ramko performance yourself. Free 10-day evaluation period and 2-year warranty guarantee you get the best.



### TURNTABLE PREAMPS MP-8 \$72 (Mono) SP-8 \$114 (Stereo)

Outstanding sensitivity and incomparable reproduction. RIAA/NAB equalized  $\pm 1$ db. 0.5mv sensitivity (internally adjustable) at 1kHz for  $-4$ dbm out.  $-20$ dbm out max. Balanced 125/600 ohm outputs.  $-73$ db S/N referenced to 10mv @ 1kHz. 0.075% or less distortion. External terminals for brilliance, rolloff or RIAA equalization. 140mv @ 1kHz headroom. Internal power supply. MP-8 Mono, SP-8 Stereo. Tabletop or bracket mount. Shipping weight 4½ lbs.

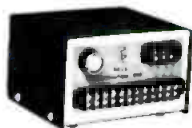

### DISTRIBUTION AMPLIFIERS DA-6 \$109 (Rack Mount Available)

Individual output amps provide maximum isolation.  $\pm 0.5$ db response. 10Hz to 20kHz. 26db gain. Balanced bridging or matching input. Six balanced 600 ohm outputs.  $+20$ dbm out max. Output level control. 0.1% or less distortion. Internal power supply. Tabletop or bracket mount. Shipping weight 4 lbs. Other models feature output metering and up to 32 outputs, \$138 to \$425.



### AUTOMATIC CART & CASSETTE LOADERS ACL-25 \$159 (Speed & Tone Sense Options Available)

At last automatic precision winding at a price you can afford! Eliminates guesswork because dials set tape length to the second. The exact amount of tape is fed onto the cart or cassette, then it is shut off automatically. Exclusive torsion control for proper tape pack and winding of various hub sizes. TTL digital control circuitry. With speed or tone sense options, \$266 to \$350. Shipping weight 30 lbs.

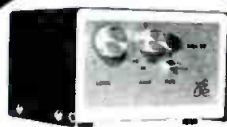

### STUDIO MONITOR AMPLIFIERS SMA-50 \$105 (Rack Mount, Mono & Stereo Options)

Exceptional reproduction! Internal muting.  $\pm 1$ db response, 20Hz to 40kHz. 25w music power. 50w instantaneous peak power, 15w rms. Hum and noise.  $-65$ db below rated output. Distortion less than 1% at 15w rms; typically below 0.25% at less than full power. Load impedance, 4, 8, 16 ohms; input balanced bridging, 100kohms. Variable base contour. Internal overload protection. Internal power supply. Tabletop or bracket mount. Rack units, \$128 to \$169. Shipping wt. 6 lbs.

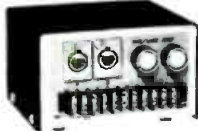

### MIC/LINE AMPLIFIERS MLA-1 \$84 (Mono) MLA-2 \$112 (Stereo or Dual Mono)

Dual function utility amps. Inputs for mic and/or line.  $-0.5$ db response. 10Hz to 20kHz. Mic input  $-65$ db for  $+4$ dbm out. Balanced inputs on high-level and mic channels. Balanced 600 ohm out.  $-20$ dbm out max. 0.1% or less distortion. Internal power supply. Tabletop or bracket mount. Shipping weight: 4 lbs.



### COLLIMETERS (Precision Tape Head & Guide Alignment) Standard, C-II \$15 Multi-Cart, C-IV \$19

A Ramko exclusive! Designed by Ramko to speed up tape head and guide alignment on all cart machines. Now used by more than 5,000 engineers. Unique combination of optical and electro-sensing elements allows you to precisely adjust Height, Zenith, and Azimuth on all cartridge machines.

ORDER TODAY FOR 10-DAY TRIAL PERIOD.  
Compare Ramko performance yourself.



**Ramko Research** Professional Audio Products

3516-B LaGrande Blvd., P.O. Box 6031  
Sacramento, California 95860 (916) 392-2100

However, I might make that kind of mistake if it was a telephone number or a machine part number instead of a count or a price. In other words, if I am looking at numerals as identifications rather than as values, I see them differently. What does this tell us? It could be that most people do not read prices as values, just as a sort of label. Very few check their change, possibly for the same reason.

I'm often asked for material on good teaching practices, particularly relevant to engineering, especially dealing with this business of seeing things clearly and accurately. According to educator Carl Salser, the most efficient approach is to use individualized instruction so the teacher is freed to deal with specific difficulties instead of trying to keep the whole class at the same place in their studies. And this is in db's ball park in several ways. Not only are properly trained individuals necessary for the right functioning of engineering situations, but the very materials used in individual instruction—such as cassettes and recordings—are often the direct business of audio people.

Individualized instruction, like any other form, can be misused. This brings us to the core of the matter, the instructor. What is the proper role for the teacher and other members of the educational fraternity if today's system is to really fulfill the expectations that taxpayers somewhat legitimately have somewhere back in their grey matter?

What my own mind keeps coming back to is that a good teacher can allow a whole classroom full of students to *study* individually without needing to have a special form of individualized instruction. True, as Carl insists, having good individualized instruction makes doing that much easier, but it only works *if that is what the teacher wants to do anyway*, which all too often is not the case. The fact is, most teachers are plain scared of the notion of having a whole roomful of students, each studying something different from all the others.

Let me use an analogy. If you know how to drive, you can drive along any highway in the United States. You do not need to have memorized the entire road map of the United States, before you can leave your own front door, do you? The important things to learn are how to drive, on different kinds of highway, in different types of vehicles, in different weather conditions, how to read road signs, and how to read a road map.

With that kind of preparation, your drivers' ed instructor can sign you out, have you pass your state's driving



**Superb performance - lavish engineering  
- a new standard in high fidelity**



**THE ALL NEW REVOX 700 SERIES**

**Stereo Tape Recorder A700    Digital Stereo Tuner/Pre-amplifier A720    Power Amplifier A722**

Revox Corporation in USA; 155 Michael Drive, Syosset, NY 11791 & 3637 Cahuenga Blvd. West, Hollywood, California 90068  
Revox in England; Lamb House, Church Street, London W42PB    Revox Sales and Service in Canada.

*Circle 26 on Reader Service Card*



# Because people and their professions are many and varied... so are Telex headphones.

Telex makes many headphones for many kinds of people. From sportscasters and pilots to ham radio operators and those who simply enjoy listening.

Telex headphones range from feather-weight units ideally suited for dictation, transcription, private radio and TV listening, to professional communications models featuring boom mics, and audiometric-type transducers impervious to temperature and humidity changes.

We make two series of professional models to meet your needs... Series 1325 for stereo monitoring and Series 1320 for communications, with optional noise-cancelling boom microphones.

General purpose headphones include the Telex Announcers Earset\*—inconspicuous for 'on camera' work and prac-

tically the standard of the industry—and the Teleset®, Twinset® and Earset® headphones for lightweight, comfortable and inexpensive private monitoring.

In all, there's a Telex headphone to match both your communications requirement, and your budget. For proof, write Telex Communications, Inc., 9600 Aldrich Avenue South, Minneapolis, Minnesota 55420.

PRODUCTS OF SOUND RESEARCH  
**TELEX**  
COMMUNICATIONS, INC.

CANADA: Double Diamond Electronics Ltd.  
Scarborough, Ontario

INTERNATIONAL: Telex Export Dept., 9600 Aldrich Avenue South,  
Minneapolis, Minn. 55420 U.S.A.

7312

test, and off you go on your own, wherever you want to go. Why can't learning be like that?

Honestly, can someone give me a reason why it can't? Because I really believe it can be like that. In a great variety of situations, I have found that approach works, every time. Just help the student to learn how to find out what he needs to know or do, and he can learn anything he wants to. I don't have to know all the stuff he expects to learn, before I can let him loose on it, any more than the Dallas drivers' ed instructor needs to know Chicago before he can let someone he has previously taught to drive take a plane to Chicago and rent a Hertz car there!

When the teacher starts to view his role that way, he will cease to worry if he finds he does not know something the student is trying to learn. It's the student's task to find that out, not the teacher's. What the teacher needs to know is *how to go about finding out*. But teacher does not have to *do* the finding out. In fact, it is better if he lets the student do that. Students will have difficulties, of course. That is why they have to learn. It still is, or should be, the job of teachers to help them with those difficulties. The teacher needs to know the *game plan* for good learning, *not* all the answers. Instead of which, most teachers have their own game plan, which usually has nothing to do with learning, unfortunately.

With some teachers, if the student can somehow get hold of the correct answer, from the back of the book, from another student, or somewhere, and then fudge something that looks like working, he has it made. So that becomes the game plan. The student will never in a million years learn to solve a problem that way, but he *will* get those necessary passing grades!

This has become so much an integral part of the system that, as I commented previously, when a good teacher starts to encourage a student who is apparently good—meaning he has always gotten passing grades—to find out how to solve problems for himself, the poor student does not know "what teacher expects of me." That is a game plan the student has never encountered before!

Perhaps some readers are more aware of the truth of this than I am, because I still have trouble believing it—it is so different from the way I learned what school taught me. Nowadays, it appears, the straight-A students are the ones who acquire all the known "game plans:" the teacher who expects it done this way, that way, whatever. This is because teachers who do not think, and do not

# Bob Dylan Comes Home

...ck messiahs, like their  
ptural models, need a  
-for the auspicious. The  
nd Coming of Bob Dylan  
aged in the city where it  
began — should appease  
adventists of the cult.  
es, there have been many  
er cities and thousands  
other A. J. Webergmans  
serenade on the traveling  
istrel show that pitched  
glittery tent at Madison  
are Garden last night.

crowds go. They moved  
meekly when the guards told  
them to clear the aisles.  
was an exuberant audience  
but far from the hushhush  
of other concerts.

Dylan was into "Lay  
Lay." in his black su  
ruffled shirt with  
piping, he looked like  
between a rabbinical  
and a cowboy. And he  
very small on

But the vo  
eclamatory.  
ve, less the  
veet quaver  
At times, a  
n of "Just  
" he sang  
back arch  
ics.

here is a  
delivery  
ata rages  
singing

Mary Travers, who he  
make the song a '60s cla  
was in the audience, swa  
the music.

## 20,000 at Garden Dig That Old Dylan Music

## Bob Dylan comes ba from the edge

Wandering through the crowd during intern  
Concert last Wednesday night, one got a sense c  
have been an agonizing decision for Bob Dylan  
of why "the Bi

ardom has a way  
ound like a d  
omerang. The city  
ob Dylan on the stre  
aspable of leaving

## Blue Jeans For Bob Dylan

Bob Dylan closed his Madison Square  
den concert the other night with  
owin' in the Wind" ("how many  
ies must the cannon balls fly/before  
y're forever banned"), which may  
all be the nearest thing to a  
e peace movement had. Be  
one on the stage with  
nd guitar, Dylan  
hey Are A-Changin'  
arly pois  
give to  
the

## Dylan Ends Stand Here With 'See Ya Next Year'

two concerts yester-  
Bob Dylan and the  
Madison Square  
to reinforce  
their first  
music. This  
ded a  
ey had  
y never  
dness: the  
the occasion to  
e aside. This su-  
suced, superbly en-  
tour isn't over yet.  
can't help thinking  
New York conce  
ved back upon

Dylan's concerts rem  
reaffirmation of  
deep and positive  
ences, and that  
of us hope  
simultaneous  
Mr. Dy  
style the  
and  
no  
the

## To record Bob Dylan and The Band... Wally Heider, Phil Ramone, Rob Fraboni, and Automated Processes

Bob Dylan's first New York concert in years...  
the high point of his 21-city tour... was Page 1 news.



Phil Ramone at the Auto-  
mated Processes console,  
the Bob Dylan concert in  
Madison Square Garden.

To record this live concert,  
Wally Heider Recording,  
the world's leading remote  
recording organization, Phil  
Ramone and Rob Fraboni,  
the recording engineers for  
the session, used a console  
manufactured by Automate  
d Processes.

Heider's new studio/re-  
mote console was shipped

directly from the Automated factory to Madison  
Square Garden\*. Set-up time was under two hours.  
No trial sessions. No retakes. Three shows. And the  
remote crew recorded another historical musical oc-  
casion for posterity.

Great talent deserves great equipment.

The Automated Processes complete line of pro-  
fessional audio consoles afford flexibility in use, re-  
liability in studio service and quality performance over  
a long, trouble-free life, at surprisingly reasonable  
cost. Send for details.

\*This is Heider's third Automated console. His first was  
delivered from the factory directly to NBC's coverage of  
the Motion Picture Academy's Awards, 1971.

**AUTOMATED PROCESSES, INC.**  
80 MARCUS DRIVE, MELVILLE, NEW YORK 11746 516-694-9212

West of Rockies: WESTLAKE AUDIO: Los Angeles, Calif. United Kingdom: 3M U.K., London, England  
Europe: 3M FRANCE, Paris, France Japan: NISSHD IWAI, Tokyo, Japan

## Up on Stage: Adrenalin Time

You could sense it even be-  
fore the concert began. The  
audience was expectant, even  
tremulous. And when Bob Dy-  
lan and the Band trotted on  
the last night at Madison  
Square Garden for the  
Manhattan concert, they  
were exultant, too.  
Nothing much was  
in the air.  
n matters of forma-  
tion from the co-  
ncert night at the Na-  
tional Academy of Mu-  
sic, at least in  
half. But the adren-  
alin was flowing, and every-  
one was different, after all.  
One of the great rock  
concerts.

# Dylan Sends Garden Into Mature Frenzy

Staring impassively into  
the darkness, Bob Dylan grit-  
ted the words, "an honor to  
be here," and sent 20,000  
fans into a mature frenzy  
last night.

At last he was playing "the  
big one," as he has called his  
return to New York City, and  
a joyous, electric crowd wel-  
comed him as he brought it  
back home.

Only a mile from the tiny  
coffee houses of Greenwich  
Village, where he became a  
national figure in the early  
1960s, Mr. Dylan

cited as it awaited the show,  
knowing that Mr. Dylan had  
not given a concert tour in  
eight years.

When he greeted them  
with his familiar opening,  
"I'll go

the seclusion of his life with  
his wife and five children in  
California.

"This is it," Gary DeFries  
said. "He'll never be back,  
maybe. I've been waiting 10  
years to see him. And this is

## For Dylan, the Dollars Are a Changin'

The show Bob Dylan and  
the Band put on at Madison  
Square Garden is the mid-  
point climax of what should  
wind up as one of the most  
profitable rock 'n' roll tours  
ever produced.

that is, to reach \$1-million in  
sales. Some, including his  
first album, released in 1962.  
"The Times They Are a  
Changin'" (1964) and "An-  
other Side of Bob Dylan  
(1964)

of love—proving that Mr.  
Dylan, as lines of age show  
in his own face, has become  
a man for most ages.

### Last-Minute Check

Earlier in the day, Mr. Dy-  
lan and his group, the Band,  
visited the Garden to perform  
a "sound check" of the equip-  
ment in the vawning aren-

\$110,000 for a chartered B  
ing 707, according to Jo-  
neys Near and Far, the L  
Angeles travel agency th  
booked hotels, limousines

## Model 521 Series Electronic Crossover

# If your tweeters are "tweeting" when your woofers should be "woofing"

... and your amps are crying uncle, try our new model 521 active crossovers. They let you select the optimum crossover frequencies for your two or three way speaker systems. No need to change fixed components to adjust crossovers. 521 plug-in cards are continuously tunable from 200 Hz to 2 kHz (521-L) and 1 kHz to 10 kHz (521-H). The 521-P shown below holds four crossover cards with its own internal power supply (optional). For larger installations, up to eleven cards can be mounted in 3½" of rack space.

The 521 series ahead of your own good power amps give the "go" signal to increased efficiency of all two and three way systems. Send for complete technical information today.

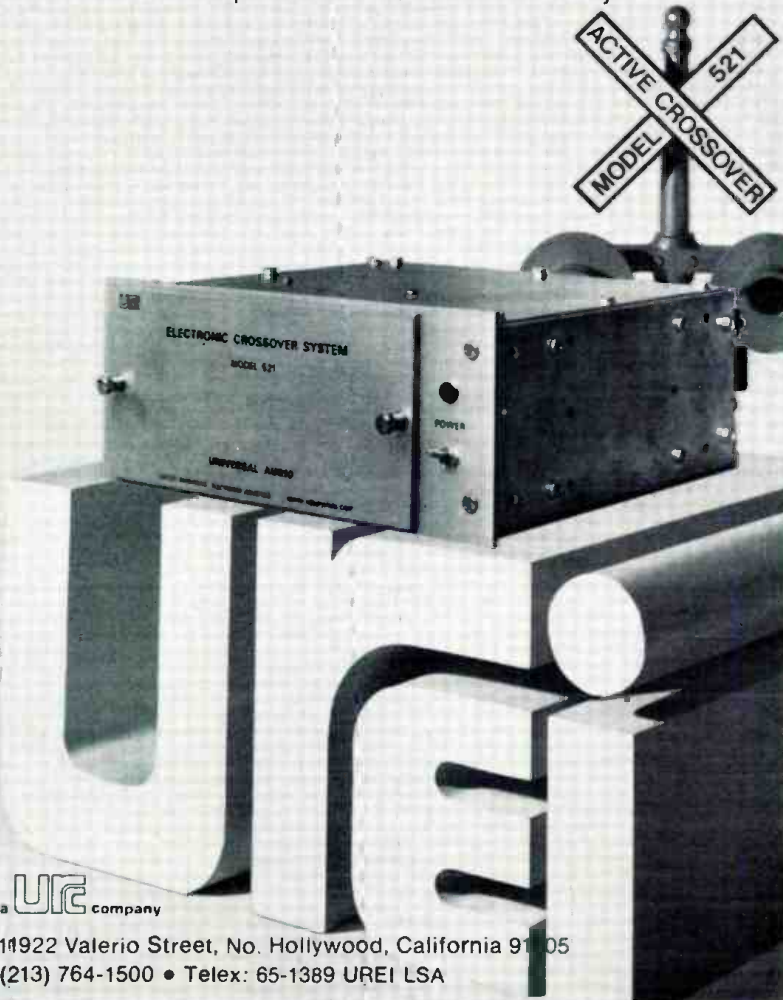

**URA**  
a company

11922 Valerio Street, No. Hollywood, California 91605  
(213) 764-1500 • Telex: 65-1389 UREI LSA

seriously expect their students to think, are themselves pretty predictable, to a smart student. This is the scene in today's schools.

The students who think school is there to prepare them for life, to learn how to cope, are "all wet." Sorry, but that includes me! And these students get poor grades because they never learn the rules of the game—they are too busy struggling to learn in spite of all the stupid barricades the system puts up, apparently to prevent learning. Many of them drop out. Most of them would make good engineers, but they never get good enough grades in math and all the other prerequisites to stand a chance.

That is why I would like to change and, from the response I get from many readers, I gather that I am not alone in that notion. Many write to ask, "How? What can we do?" Some of the pieces to the answer could conceivably be implemented with audio, somehow. But far more of them are really a matter of how to get things done differently from the way the system has done them for a long while, which it is very reluctant to change. So that ain't easy! But that makes it all the more well worth addressing.

We have some options open, as to where to address them. Some readers would like to see more of that kind of material in this column. But, as I say, I am reluctant to venture too far in that direction. It might have a demonstrable connection with theory and practice, but much of it would contain no audio aspects whatever, and very little engineering, unless you think of "how to win friends and influence people" as engineering!

To be honest, while the greetings I received this year indicate that I have won some very interesting and loyal friends, there must be easier ways to get more instant recognition! Unfortunately, I am one of those people who would rather do something that gives me satisfaction of feeling I have done a job well than gain instant recognition for something that I myself would always be a little unhappy about. So I don't fit the system at all readily.

When we studied for citizenship, which is going on for fifteen years ago now, we gained the impression that this is what this nation was all about: people worked hard, doing worthwhile things, and finding reward for that effort. But during that nearly fifteen years, we have been progressively getting the impression that the past tense is absolutely correct—that is what it was all about! However, something inside keeps me alert for some sign that we could once more justifiably write that in the present tense.



## Series 70 Recorder/Reproducers

# When you've got more talent than money

TASCAM Series 70 recorder/reproducers were designed for people who've outgrown high-end consumer audio products but can't afford full professional studio gear.

Whether you need single, two or four channels, you define the Series 70...it doesn't define you. Your choices are expanded instead of restricted without paying a performance penalty.

The versatile Series 70 electronics come in two versions, one for direct recording and one for use with a mixing console like our Model 10. Either way you'll find uncommon quality and reliability.

Series 70 recorder/reproducers. When you've got more talent than money.



**TASCAM** CORPORATION



5440 McConnell Avenue  
Los Angeles, Calif. 90066

Circle 29 on Reader Service Card

Martin Dickstein

## SOUND WITH IMAGES

● Some months ago, this column was devoted to a two-part discussion on the care of audio/visual equipment. The second segment dealt with 16mm projectors, and several questions were raised as originally voiced by equipment users who felt that they would appreciate getting more maintenance

hints from the audio/visual suppliers. One of the questions that had come up had to do with whether it was better to run a projector's fan after the lamp was off following a showing or whether it made any difference at all to the life of the lamp. We then requested that our readers let us know of their experiences.

Among the answers came a letter from William A. Kingman, Chief Engineer of Stations KTHO and KTHO-FM, South Lake Tahoe, California. He makes some very interesting and enlightening comments on the subject, and is most qualified in this matter, as you will see. We thank him for the letter and his permission to use the major portion of it.

**Plastic Reels** Shipped from Inventory  
Mfrs. of Amerline reels  
**Polyline Corp.**  
312/298-5300  
1241-Rand Rd. Des Plaines, Ill. 60016



Circle 31 on Reader Service Card

## new pocket sized professional sound level meter for under \$100



The new Scott 451C sound level meter is the first truly professional instrument that fits in your pocket and costs only pocket money.

It gives instant readings at the touch of a button to ANSI type S3C accuracy with industry standard "C" weighting for flat response. Its range of 45 to 130dB SPL lets you check ambient background levels as well as the signals of interest. It measures the complete range of sounds likely to be encountered by the audio engineer or the advanced audiophile.

It's got a handsome, rugged all metal case and a big meter face that's easy to read. It's also a lot of fun to use. Its battery lasts all year. It lasts indefinitely and it's fully guaranteed for two years. It costs only \$98.00. It's available from distributors whose names we'll send you with full product specifications.

**Scott Instrument Laboratories**  
Division of Eastern Air Devices  
30 Cross Street  
Cambridge, MA 02139



Circle 16 on Reader Service Card

"It has been my experience that the cooling of a projection lamp should not be excessive. Common life expectancy of a projection lamp run 10-15 hours; by leaving the cooling fan running until the vented air is no longer hot, I have experienced almost double the normal lamp lifetime many times. I equate this to the case of automobiles: when you turn the ignition off, cooling circulation ceases and the engine temperature literally skyrockets. In projectors, this effect can be seen sometimes in the form of a bubble or lump on the projection lamp's glass where it becomes so hot as to be soft: Bell & Howell 16mm sound projectors seem to be particularly prone to this situation if not permitted adequate cooling by fan after the lamp is turned off. It is not possible to cool the lamp below the ambient room temperature (unless the air is from a cooler source than the room), evidenced by the fact that a thermometer held in front of a fan does not show a temperature change.

"Assuming proper projector cooling design, probably the two most influential factors in lamp life are adequate 'after cooling' to avoid the skyrocket-heat effect, and proper line voltage to the lamp. A mere difference of 5 percent in line voltage can change lamp life by 50 percent. By running the projection lamp at 5 percent under its rated voltage, it may last 50 percent or more longer than normal. However, it will deliver 10-15 percent less light output (lumens). We can't get something for nothing! Some projectors now provide switchable voltage levels for the lamp to extend lamp life; the switch labelled 'Low' and 'High' is the typical case (Eastman Kodak). Ideally, the lamp should be started at low voltage and then adjusted up to the desired output.

"Another important point in extending the life of a projection lamp is avoiding line voltage surges. Most projectors are wired so that the lamp cannot be turned on without the cooling fan (projector motor) operating first. In older projectors, the separate two 'Motor' and 'Lamp' switches were wired in series for this purpose; many new machines use a common 3-position switch with lamp voltage supplied in the third position. The reasons for this are twofold: the lamp cannot operate without cooling, and the a.c. cannot blow the lamp with excessive voltage. Whereas the 3-position switch projectors protect themselves, the 'Motor' and 'Lamp' separate switches on older projectors can be operated erroneously with ex-

actly the opposite result—a destroyed lamp. For example, an operator turns on the 'Lamp' switch first and nothing happens; then he turns on the 'Motor' switch and an enormous a.c. surge hits both the motor and lamp simultaneously! Moral: *Always* turn on the motor *first*, and always turn off the motor *last*.

" . . . I would like to note another aspect of 16mm sound projectors: the sound head. In many respects, the optical sound system resembles the methods of the magnetic tape recorder in obtaining proper adjustment, in terms of azimuth and zenith, and, to the analogous extent, head gap. It has been my experience that the sound head receives less attention than the other items maintained in most 16-mm projectors, yet its proper adjustment is as rewarding as cleaning a clogged tape head or replacing a flattened phonograph needle!

"Essentially, the very narrow slit of light from the sound exciter lamp must be adjusted to the optical sound track just as the narrow gap of a tape head must be aligned to the magnetic lines of a tape for proper playback for maximum high-frequency audio response and output level. And the optical sound head is just about as touchy as the tape playback head! Different projector makes have different approaches to accomplish the same goal, physically and logistically, but the common principle remains that of focusing the slit of light precisely on the sound track. Most projectors have a form of lock nut or tightening screw which anchors the position of the sound lens. With this setting loosened slightly, very carefully but *slightly* adjust both the *proximity* and *rotation* of the sound lens with respect to the film's surface while the projector is running and you are listening for maximum high-frequency response. Far preferable to this ear-shot method would be the use of a standard test film of recorded high frequency tones while observing the output on a vtm or vu meter, just as with an alignment tape.

"But, again, there are exceptions, and one is especially unique to film alone: emulsion side. While a tape always presses its oxide side surface to the playback head, the equivalent *emulsion* of film may or may not be on the surface side of the sound head. Therefore, where a projector may be adjusted for optimum performance on a film whose emulsion side presses against the sound drum surface, another film with its emulsion on the opposite side (A-wind versus B-wind) will be both out-of-focus on the screen and out-of-focus to the sound head, both to the extent of the film's

# Sound Engineering for Sound Engineers

## The MITS, SG 1900 Audio Sweep Generator



The MITS SG 1900 Audio Sweep Generator joins the expanding MITS line of test equipment as a most versatile piece of equipment necessary to both the beginning hobbyist and the seasoned electronics enthusiast. Significant innovations in integrated circuitry have made this laboratory quality instrument available at the lowest possible cost.

Its many applications include the following:

- Simplification in setting a tape recorder's bias and aligning head azimuth.
- Easy checking of line and load regulation and output impedance vs. frequency for power supplies.
- Testing room and speaker enclosure resonance, microphone element sensitivity, ultrasonic system response, phase locked loops, SSB filters, and telecommunications systems.
- And many more all-audio applications.

### SPECIFICATIONS:

- Modes: CW, linear sweep, log sweep ● Waveforms: sine, square, triangle
- Range (5 steps): 1 to 100,000 Hz ● Response:  $\pm 0.1\%$ , to 20,000 Hz;  $\pm 0.15\%$ , to 100,000 Hz ● Distortion (sine): 1.5%, 10 to 20,000 Hz
- Rise time (square): 2  $\mu$  sec ● Output Voltage: 0-5 V rms sine; 0-7 peak sine, square, triangle ● Attenuator: 0, 20, 40 dB  $\pm 1$  dB; 600 ohms constant impedance ● Sweep time (2 steps): 10 ms to 100 s ● Sweep output (ramp): 0 to 5 V, 5000 ohms output impedance ● Sync Outputs: 4-V positive pulses, 5000 ohms impedance. Sweep sync pulse starts at the end of the sweep, returns to zero at the start of the next sweep. Can be used for blanking; 5  $\mu$  sec rise time. Wave sync is square wave, amplitude is independent of control settings; 0.5  $\mu$  sec (maximum) rise time.

CASE SIZE: 13" x 4" x 6"

POWER REQUIREMENTS: 110/220 VAC, 50/60 Hz, 10 watts

\*PRICES: Kit . . . . . \$119.95 Assembled . . . . . \$149.95

WARRANTY: Full two-years warranty on assembled units, ninety days on kits.

\*Prices subject to change without notice.

MITS makes a full line of Electronic Calculators and Test Equipment.

**MITS** INC.

"Creative Electronics"

6328 Linn, N.E., Albuquerque, New Mexico 87108  
505/265-7553 Telex Number: 660401

Enclosed is a Check for \$ \_\_\_\_\_

or  BankAmericard # \_\_\_\_\_

or  Master Charge # \_\_\_\_\_

Credit Card Expiration Date \_\_\_\_\_  Kit

Include \$5.00 for Postage and Handling  Assembled

SG 1900 Audio Sweep Generator

Please Send Information on Entire MITS Line.

NAME \_\_\_\_\_

ADDRESS \_\_\_\_\_

CITY \_\_\_\_\_

STATE & ZIP \_\_\_\_\_

MITS/ 6328 Linn, N.E., Albuquerque, New Mexico 87108 505/265-7553 Telex # 660401

DB-3-74

## Are Your Test Tapes **REALLY** Reliable And Accurate? If They're STL they are.

It's just possible your system may be out of step with the rest of the industry. We offer precision test tapes made on precision equipment for specific jobs in 1" and 2" sizes as well as flutter tapes and all other formats. They are available in more sizes than that offered by any other manufacturer in the world. Order STL test tapes and find out where your system really is.

Write for a free brochure and the dealer in your area. Distributed exclusively by Taber Manufacturing & Engineering Co.

**STL** STANDARD TAPE LABORATORY, Inc.  
2081 Edison Avenue  
San Leandro, CA 94577  
(415) 635-3805

Circle 32 on Reader Service Card

thickness. The effect on the sound reproduction is not quite as obvious as threading the wrong surface of a tape across the playback head, but the cause is the same—the recorded sound is not 'focused' precisely on the playback head. This problem is as common as the number of reels of film with emulsion surfaces on opposite sides.

"Mass-duplicated prints are often wound 'opposite' emulsion as compared to your own original footage, readily evidenced by the need to re-focus the image between films . . . but what about focusing the sound image? Unfortunately, very few projectors include this vital adjustment in their operating designs (short of making the complete alignment adjustment described above, certainly impractical for daily operation). The early model Eastman Kodak Pageant 16mm home-type sound projectors included an ingeniously simple focusing control labeled 'Fidelity' for precisely this purpose, which worked very well. It was a simple sliding lever which produced very obvious results from film to film. But Kodak eliminated this feature many years ago, either because of cost or because most people just didn't understand it and used it as a tone control! (It *might* exist still on the special Audio-Visual models—I can't confirm this.) It would be a boon to film audio if all projectors would include a sound focus control as Kodak once tried, but just as important would be *using* it!

"I hope that I may have contributed some useful information for your article someday, Mr. Dickstein. 16-mm sound projectors have been a hobby of mine since 1950."

We should like to suggest to our readers that one easy way to make use of the operating fan to cool the projector while the lamp is off is to try to rewind the film on the projector (not through the normal film path but in the speedy rewind position) rather than on table rewinds. It's easier on the arm, and faster, and will cool the lamp at the same time.

All we can add to this is that you certainly have contributed, Mr. Kingman, to the interest and enlightenment of all our readers. We thank you again for sharing your experiences and special knowledge with the rest of us.

We hope that those of our readers who have had special experiences and have gained in knowledge will contribute likewise so that we can all share in some of the thoughts and ideas you may have in any phase of the audio/visual/video fields. ■

# "Rock Talk"

as spoken by: WAR, Elvin Bishop, Sha-Na-Na, Uriah Heep, Tower of Power, Doobie Bros., Radio City Music Hall, Harry McCune Sound, Northwest Sound, Carlos Sound and many other professionals.



## CLEAR-COM PORTABLE INTERCOM SYSTEM

Exceptionally clear voice intercommunication for lighting, mixing, and sound reinforcement crews at concerts and recording remotes. Reliability and performance proven by constant professional use. Clear-Com is a wired system using standard 2-conductor, shielded microphone cable to connect all stations. One main station powers up to 30 remote belt-pack stations. All stations are equipped with headphones and dynamic high-intensity noise-canceling microphones.

Custom features for concert and recording groups include:

- Individual volume control at each station
- Call light signaling to back up audio system
- Complete portability
- Rugged all-metal construction for total reliability

Full one-year warranty guarantees all components. Write or call today for the dealer nearest you:

**CLEAR-COM** DIVISION OF LUMIERE PRODUCTIONS, INC.  
759 Harrison Street, San Francisco, CA 94107 (415) 989-1130

Circle 24 on Reader Service Card



# NEW PRODUCTS AND SERVICES

## PORTABLE PUBLIC ADDRESS SYSTEM

● This is a complete system, including a lectern containing the electronic circuitry, with a lamp that mounts on the top, and two microphones, one a lavalier model and the other a conventional swivel-neck mic that attaches to the lectern. The lectern also contains a storage area. Known as the Port-address, the system provides four individually controlled inputs, two for the microphones, a low-level input for a phonograph and a line input for a tape recorder or movie projector. The two loudspeakers attach together to become a single unit with an integral carrying handle.

*Mfr: Electro-Sound*

*Price: \$749.00*

*Circle 35 on Reader Service Card*



## STEREO PREAMPLIFIER



● Known as the Zero-Distortion Pre-amp, this unit is designed without tone controls; all tone controls and other response filtering should be accomplished in the equalizer. All high-level amplifiers have been removed, resulting in the absence of non-linear elements and making possible a circuitry which is resistive at all settings of the controls. Specifications include unity-gain on high-level inputs, no error from tone controls, flat frequency response (to d.c.), phono noise of  $-76$  dB, equalization accurate within  $\pm 0.5$  dB, and phono distortion of 0.05 percent. The Zero-Distortion Preamp can drive any equalizer or power amplifier if the input impedance is 50k or greater.

*Mfr: Ace Audio Co.*

*Price: Kit: \$69.95; Wired: \$87.50.*

*Circle 38 on Reader Service Card*

## OPEN REEL TAPE DECK

● Application of speeds of 15 and  $7\frac{1}{2}$  inches per second and accommodation of  $10\frac{1}{2}$ -inch reel capacity characterizes model TC-755 three-motor open reel tape deck. A servo-control motor adjusts immediately to any live voltage changes; closed loop dual capstan tape drive; Ferrite heads, with high dimensional accuracy. The deck also has a total mechanism shut-off and a mechanical memory capability that works with an optional timer to engage the tape drive mechanism at pre-set time, even in the absence of the operator. Other features include a record equalization selector and accessible bias switching for optimum performance from any type of recording tape, variable playback volume control with detents to pre-set the playback level for monitoring, two pro-type vu meters, mic/line mixing, adjustable tape height guides and a three-position microphone attenuator switch, as well as a four-digit tape counter.

*Mfr: Superscope (Sony)*

*Price: \$799.95*

*Circle 36 on Reader Service Card*



## LONG THROW HORN



● This throw horn is forty inches long and carries 300 Hz power. Useful for focusing on back walls. Comes with a heavy duty carrying case.

*Mfr: Heil Sound Systemn*

*Circle 37 on Reader Service Card*

## HIGH POWERED AMPLIFIERS

● These new amplifiers, Mark 111C and Mark 111CM, incorporate a relay protection circuit which guards the loudspeaker in the event of amplifier failure; if any d.c. or very low frequencies appear, the amp will be disconnected from the load until the problem is solved. Inferior tuner muting circuits, "flicking" the stylus clean, or dropping the needle on the record will also disconnect the loudspeaker. Both units have a rated output of 200 watts rms/channel into eight ohms. They also feature a thermal cut-out for high temperature protection, two B+ and two B- fuses; and an a.c. line fuse. They will deliver full power (40V rms) into one ufd/8 ohms at 20 kHz at less than .1 percent distortion. The amplifiers are reported not to oscillate under any load conditions, regardless of phase angle. 98 percent of all wiring has been eliminated, through the use of interconnecting P.C. boards.

*Mfr: Scientific Audio Electronics, Inc.  
Circle 39 on Reader Service Card*



## SEMI-AUTOMATIC TAPE SPLICER



● Model TS 250 semi-automatic 1/4-inch magnetic tape splicer is designed to cut and position a measured portion of splicing tape with no contamination to weaken the splice. Separate non-magnetic stainless shears cut the tapes and a nylon holder, which can be raised out of the way, holds the 7/32-inch splicing tape. A .240-inch dovetail groove is hand-machined into an aluminum base. All parts are adjustable.

*Mfr: NRP*

*Price: \$49.95*

*Circle 43 on Reader Service Card*

## HIGH-OUTPUT, LOW NOISE PROFESSIONAL MASTERING TAPES

● A new iron oxide, a new binder system, and a new dispersion process are incorporated into models 2506 and 3607 mastering tapes. The tapes are reinforced by back-coating to protect them during handling and storage. They are available in two base thicknesses and lengths, both made in 1/4 inch, 1/2 inch, one inch, and two inch widths. 2506 has a base of 1.5 mil polyester and is 2500 feet long. 3607 is 3600 feet long with a base of 1.0 mil polyester. Reel diameters for both tapes is 10 1/2 inches.

*Mfr: Audio Devices, Inc.*

*Circle 40 on Reader Service Card*

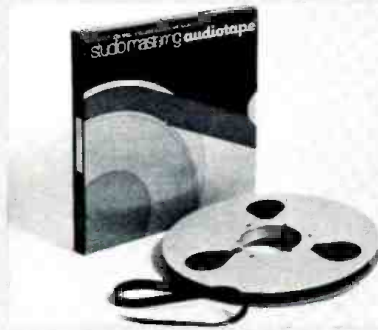

## TRIANGLE WAVE OSCILLATOR



● Phasing, rotating sound and reel flanging effects can be created automatically by plugging type 969 oscillator into models 968 or 968A phase shifters. Powered continuously for one year by a self-contained nine volt battery, the oscillator covers a frequency range from one cycle per minute to one hundred cycles per second.

*Mfr: Countryman Associates*

*Circle 42 on Reader Service Card*

## COLOR CODED ZIPTAPE

● This cartridge of over 1,000 inches of tape is now available in the NEMA code of colors in addition to the previously offered white tape with alphabetical and/or numerical symbols. The tape is plasticized and pressure sensitive with high tac adhesive for instant use. The dispensing unit has a capacity of ten individual cartridges, each with a built-in spooling device. The tape is reasonably oilproof, waterproof, acid resistant; its vinyl coated surface will allow any vinyl marking instrument to be used. It will withstand temperatures to 270 degrees Fahrenheit.

*Mfr: The Zippertubing Co.*

*Circle 41 on Reader Service Card*



## CASSETTE DUPLICATING SYSTEM



Over 10,000 C-30 copies in eight hours can be duplicated by model 1200, which runs a 3¾ inches-per-second master tape at 120 inches-per-second. The master unit will handle up to twelve four-rack reel-to-reel or reel-to-cassette slaves. Each slave accommodates a 10½ inch reel and runs at 60 inches-per-second to conform with the master's 32:1 speed ratio. Using a ¼-inch master tape, the master has automatic load and unload features to cut setup time and can be run completely unattended. Test jacks are included on the front panel of the master for use in testing and alignment and for patching two systems together. Bias and equalization are adjustable for chromium-dioxide or other high-coercivity tapes.

Mfr: Audio/Tek Inc.

Price: \$6,750

Circle 45 on Reader Service Card

## DIGITAL CLOCK



● Form C contact closures on model DC24 digital clock adapt it for a variety of broadcast timing applications, through various optional boards. A reset board provides approximate time corrections up to four times per hour. Optional boards include a net joint board which offers exact time corrections either once or twice per hour and an oscillator time base and battery backup board which maintains exact time independent of line frequency variations or power interruptions. Controls on the front panel enable the operator to halt the clock altogether, advance the seconds counter rapidly, advance the minutes counter rapidly, or light the led display momentarily when operating on battery.

Mfr: Sparta Electronics Corp.

Price: \$475 (with reset board) Net join board: \$100. Oscillator/battery backup board: \$125.

Circle 46 on Reader Service Card



## We've been hiding our light under a bushel —

### ● C1616/C2424 CONSOLE

A year ago we studied the other two low cost recording consoles and we built a unit without their shortcomings. We also put in a few extra goodies, like semi-parametric equalizers on each input. We have installations in Atlanta, Washington, Wilkes-Barre, Denver, Lancaster, and more coming. Compare before you buy your new console. Circle 15 on Reader Service Card.

### ● MOM'S WHOLESOME AUDIO MICROMIXER

If you're into PA or stereo recording requiring lots of inputs with EQ and reverb, you might want to look into our MicroMixer. Circle 16 on Reader Service Card.

### ● ORTOFON DISC CUTTING EQUIPMENT

With installations in Nashville and Chicago, Ortofon has really got their thing together. Write or call for more information.

### ● SCHOEPS MICROPHONES

We've got some new hand held condenser microphones — both cardioid and omni patterns — that are absolutely pop free. Circle 17 on Reader Service Card.



## GATELY ELECTRONICS, Inc.

57 West Hillcrest Ave.  
Havertown, Penna. 19083  
215-449-6400

1907 Division St.  
Nashville, Tenn. 37203  
615-327-1746

Circle 19 on Reader Service Card



## WORAM AUDIO ASSOCIATES

Consultants in Studio Systems  
Engineering, Design and Installation

—offering—

A COMPLETE CONSULTATION  
SERVICE FOR STUDIO  
PLANNING AND  
CONSTRUCTION

FREE-LANCE RECORDING  
SERVICE IN THE  
NEW YORK AREA

212 673-9110  
64 University Place  
New York, N.Y. 10003



professional  
power  
amplifier

# RUGGED!

The BOSE name and a full FIVE YEAR WARRANTY are your assurances of reliability and performance with the BOSE 1800™ Professional Power Amplifier.

- 800 Watts rms
- LED Displays
- Over 1,300 Square Inches of Heat Sinks
- Sturdy Packaging
- Rack Mountable

Please send complete information on the BOSE 1800 to:

Name \_\_\_\_\_

Address \_\_\_\_\_

City \_\_\_\_\_ State \_\_\_\_\_ Zip \_\_\_\_\_

Mail to: BOSE, Dept. DP,  
The Mountain, Framingham, Mass. 01701

Circle 17 on Reader Service Card

## UNIQUE WOOFER

● A full range two way loudspeaker system, model L-500A, incorporates a unique woofer with cone material which is stiff, enabling it to move like a piston at bass frequencies, yet is soft and self-damping at high frequencies to prevent cone breakup. It also incorporates a soft suspension so that it has a low resonant frequency and can move with high efficiency and accuracy. Coupled with this woofer is a one-inch diameter soft-dome tweeter that weighs 0.2 grams and operates in a magnetic field of 15,000 Gauss. It is claimed that break-up is prevented by suspending the tissue dome by its own sealed acoustic chamber and by damping out resonances with damping fluid. Available in walnut or white.

Mfr: Braun (Distributor: Analog + Digital Systems, Inc.)

Price: \$129

Circle 47 on Reader Service Card



## CUSTOM CONSOLES

● Several new versions of the Centurion series custom consoles are being offered, a monaural 12-mixer version (Centurion I), a 6-mixer stereo (Centurion IV) and a 6-mixer mono (Centurion III). These new models join Centurion II, the stereo (quadriphonic capable) 12-mixer version. Six-mixer mono or stereo extender panels have also been devised for the series, giving up to 18-mixer capacity in a single system. Available options in all models include slide or rotary attenuators, interchangeable mixer modules, digital clock, etc. The consoles feature electronic pushbutton switching, motherboard-type construction, and replaceable or additional mixer modules.

Mfr: Sparta Electronic Corp.

Circle 48 on Reader Service Card



## CLAMP METER

● Volts, amps, and resistance can be measured by models 300/600 and 1200 clamp meters. The meter is clamped around one conductor and the current read on the graduated scale. Current ranges to 1200A, voltage ranges to 600V, and resistance measurements to 5,000 ohms are standard. The clamp meter also comes equipped with lead wires for voltage measurements, a special adaptor for resistance measurement, and a carrying case. Model 300/600 measures wire sizes to 1.02 diameter and model 1200 measures wire sizes to 1.889 diameter.

Mfr: Panasonic (Matsushita Electric Corp. of America)

Circle 49 on Reader Service Card



## STEREO POWER AMPLIFIER

● Two ohm loads can be handled by model 250 amplifier, a smaller version of model 500R, from the same manufacturer. Model 250 has modular construction, with each channel on its own removable heat sink assembly. Other features include SCR crow bar circuitry, and a high speed circuit breaker. Each output stage uses six 15-amp single diffused power transistors. The unit is packaged in a cabinet having a 5¼ inch high rack panel.

*Mfr: BGW Systems*

*Price: \$429*

*Circle 50 on Reader Service Card*



## MODULAR AUTOMATION CONTROLLERS

● CD28 series of modular automation controllers can be inserted into existing systems without extensive rewiring. The basic system handles up to 2,000 events and twelve audio sources with full random access. Accessory extended memory modules expand the system to 8,000 events of pre-programmed broadcasting. To program the system, a standard input keyboard is utilized for data entry in-plays to the mos memory; led displays show the event number, function, and program source. All CD28 units interconnect by plugging them in to one another. A temperature control tunnel promotes cool air flow through the control logic.

*Mfr: Control Design Corporation*

*Circle 51 on Reader Service Card*



## LOW DISTORTION EQUALIZERS

● Two models, Mark 700 and Mark 2700 equalizers, offer low distortion tone control systems, designed to alter the frequency response, octave-by-octave of any sound system. Mark 700 incorporates eleven stereo level controls, ranging from 40 Hz to 20 Hz. Each control automatically varies both channels simultaneously. The Mark 2700 features eleven separate equalizer level controls for each channel. Both units have 22 toroidal LC band-pass filters with 12 dB/octave slopes; dual range: variable to  $\pm 16$  dB or  $\pm 8$  dB; 0 dB center detent position on all equalizer level controls; EQ defeat switch; 600 ohm output impedance.

*Mfr: Scientific Audio Electronics*

*Price: Mark 700: \$550; Mark 2700: \$600.*

*Circle 52 on Reader Service Card*



the first  
reel to reel  
with the rugged  
reliability of  
**itc**

The makers of premium quality tape cartridge equipment in the reel-to-reel market? It had to happen! The result is what you, Mr. Broadcaster, have been looking for. All the features you demand plus a few innovative optionals of our own. And all with the rugged reliability inherent in the International Tapetronics' name. Check out these plusses in your own studios. We offer a 30 day guarantee of satisfaction plus a one year warranty. Just call collect and say you want to try the "850" series. We'll do the rest.

Phone 309-828-1381



**INTERNATIONAL  
TAPETRONICS CORPORATION**

2425 South Main Street Bloomington, Illinois 61701

Marketed exclusively in Canada by  
McCurdy Radio Industries Ltd., Toronto

*Circle 20 on Reader Service Card*

# An Integrated Circuit Headphone Amplifier

*Broadcast engineers take note. This article tells you one way to get the disc jockey to handle the audio the way it should be done, rather than the way he thinks it is to be handled.*

**I**N BROADCAST and recording equipment, the monitor is typically the most neglected component. Program material is moved from source to destination with the utmost of care, but provisions for the fellow in the driver's seat are only an afterthought. The circuit developed here provides a simple, low-cost module which may be used for a variety of high quality monitoring purposes.

At my facility, the need for improvement in the monitor system was pointed out when an announcer complained about distortion in a tape recorder. A quick listening test showed no noticeable distortion, so I asked him to record with the idea of doing an A to B comparison. He promptly lowered the carefully adjusted inputs to the record amplifier, switched off the console vu meters, opened the mic pot and masters to maximum, and began shouting at the mic.

I tactfully asked if he could give me some pointers on his recording technique.

He always turned the vu meters off, it seemed, because they made an annoying click as they banged against the stops and it was necessary to turn the pots to maximum so he could hear what he was saying. After he had the head-

---

*Douglas C. Myers is chief engineer of WGSA and WIOV in Ephrata, Pa.*

# NEW PRODUCTS AND SERVICES

## PORTABLE PUBLIC ADDRESS SYSTEM

● This is a complete system, including a lectern containing the electronic circuitry, with a lamp that mounts on the top, and two microphones, one a lavalier model and the other a conventional swivel-neck mic that attaches to the lectern. The lectern also contains a storage area. Known as the Port-address, the system provides four individually controlled inputs, two for the microphones, a low-level input for a phonograph and a line input for a tape recorder or movie projector. The two loudspeakers attach together to become a single unit with an integral carrying handle.

*Mfr: Electro-Sound*

*Price: \$749.00*

*Circle 35 on Reader Service Card*



## STEREO PREAMPLIFIER



● Known as the Zero-Distortion Pre-amp, this unit is designed without tone controls; all tone controls and other response filtering should be accomplished in the equalizer. All high-level amplifiers have been removed, resulting in the absence of non-linear elements and making possible a circuitry which is resistive at all settings of the controls. Specifications include unity-gain on high-level inputs, no error from tone controls, flat frequency response (to d.c.), phono noise of  $-76$  dB, equalization accurate within  $\pm 0.5$  dB, and phono distortion of 0.05 percent. The Zero-Distortion Preamp can drive any equalizer or power amplifier if the input impedance is 50k or greater.

*Mfr: Ace Audio Co.*

*Price: Kit: \$69.95; Wired: \$87.50.*

*Circle 38 on Reader Service Card*

## OPEN REEL TAPE DECK

● Application of speeds of 15 and  $7\frac{1}{2}$  inches per second and accommodation of  $10\frac{1}{2}$ -inch reel capacity characterizes model TC-755 three-motor open reel tape deck. A servo-control motor adjusts immediately to any live voltage changes; closed loop dual capstan tape drive; Ferrite heads, with high dimensional accuracy. The deck also has a total mechanism shut-off and a mechanical memory capability that works with an optional timer to engage the tape drive mechanism at pre-set time, even in the absence of the operator. Other features include a record equalization selector and accessible bias switching for optimum performance from any type of recording tape, variable playback volume control with detents to pre-set the playback level for monitoring, two pro-type vu meters, mic/line mixing, adjustable tape height guides and a three-position microphone attenuator switch, as well as a four-digit tape counter.

*Mfr: Superscope (Sony)*

*Price: \$799.95*

*Circle 36 on Reader Service Card*



## LONG THROW HORN



● This throw horn is forty inches long and carries 300 Hz power. Useful for focusing on back walls. Comes with a heavy duty carrying case.

*Mfr: Heil Sound Systemn*

*Circle 37 on Reader Service Card*

## HIGH POWERED AMPLIFIERS

● These new amplifiers, Mark 111C and Mark 111CM, incorporate a relay protection circuit which guards the loudspeaker in the event of amplifier failure; if any d.c. or very low frequencies appear, the amp will be disconnected from the load until the problem is solved. Inferior tuner muting circuits, "flicking" the stylus clean, or dropping the needle on the record will also disconnect the loudspeaker. Both units have a rated output of 200 watts rms/channel into eight ohms. They also feature a thermal cut-out for high temperature protection, two B+ and two B- fuses; and an a.c. line fuse. They will deliver full power (40V rms) into one ufd/8 ohms at 20 kHz at less than .1 percent distortion. The amplifiers are reported not to oscillate under any load conditions, regardless of phase angle. 98 percent of all wiring has been eliminated, through the use of interconnecting P.C. boards.

Mfr: Scientific Audio Electronics, Inc.  
Circle 39 on Reader Service Card



## HIGH-OUTPUT, LOW NOISE PROFESSIONAL MASTERING TAPES

● A new iron oxide, a new binder system, and a new dispersion process are incorporated into models 2506 and 3607 mastering tapes. The tapes are reinforced by back-coating to protect them during handling and storage. They are available in two base thicknesses and lengths, both made in 1/4 inch, 1/2 inch, one inch, and two inch widths. 2506 has a base of 1.5 mil polyester and is 2500 feet long. 3607 is 3600 feet long with a base of 1.0 mil polyester. Reel diameters for both tapes is 10 1/2 inches.

Mfr: Audio Devices, Inc.  
Circle 40 on Reader Service Card



## COLOR CODED ZIPTAPE

● This cartridge of over 1,000 inches of tape is now available in the NEMA code of colors in addition to the previously offered white tape with alphabetical and/or numerical symbols. The tape is plasticized and pressure sensitive with high tac adhesive for instant use. The dispensing unit has a capacity of ten individual cartridges, each with a built-in spooling device. The tape is reasonably oilproof, waterproof, acid resistant; its vinyl coated surface will allow any vinyl marking instrument to be used. It will withstand temperatures to 270 degrees Fahrenheit.

Mfr: The Zippertubing Co.  
Circle 41 on Reader Service Card

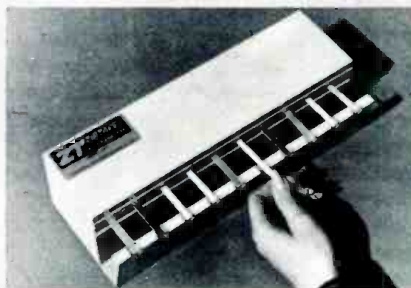

## SEMI-AUTOMATIC TAPE SPLICER

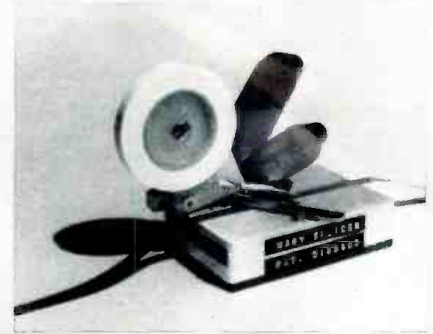

● Model TS 250 semi-automatic 1/4-inch magnetic tape splicer is designed to cut and position a measured portion of splicing tape with no contamination to weaken the splice. Separate non-magnetic stainless shears cut the tapes and a nylon holder, which can be raised out of the way, holds the 7/32-inch splicing tape. A .240-inch dovetail groove is hand-machined into an aluminum base. All parts are adjustable.

Mfr: NRP  
Price: \$49.95  
Circle 43 on Reader Service Card

## TRIANGLE WAVE OSCILLATOR



● Phasing, rotating sound and reel flanging effects can be created automatically by plugging type 969 oscillator into models 968 or 968A phase shifters. Powered continuously for one year by a self-contained nine volt battery, the oscillator covers a frequency range from one cycle per minute to one hundred cycles per second.  
Mfr: Countryman Associates  
Circle 42 on Reader Service Card



## CASSETTE DUPLICATING SYSTEM

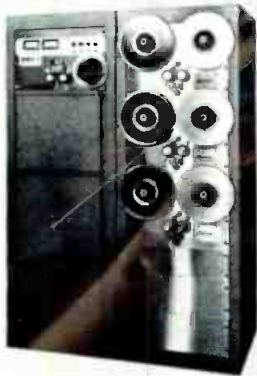

● Over 10,000 C-30 copies in eight hours can be duplicated by model 1200, which runs a 3¾ inches-per-second master tape at 120 inches-per-second. The master unit will handle up to twelve four-rack reel-to-reel or reel-to-cassette slaves. Each slave accommodates a 10½ inch reel and runs at 60 inches-per-second to conform with the master's 32:1 speed ratio. Using a ¼-inch master tape, the master has automatic load and unload features to cut setup time and can be run completely unattended. Test jacks are included on the front panel of the master for use in testing and alignment and for patching two systems together. Bias and equalization are adjustable for chromium-dioxide or other high-coercivity tapes.

*Mfr: Audio/Tek Inc.*

*Price: \$6,750*

*Circle 45 on Reader Service Card*

## DIGITAL CLOCK



● Form C contact closures on model DC24 digital clock adapt it for a variety of broadcast timing applications, through various optional boards. A reset board provides approximate time corrections up to four times per hour. Optional boards include a net joint board which offers exact time corrections either once or twice per hour and an oscillator time base and battery backup board which maintains exact time independent of line frequency variations or power interruptions. Controls on the front panel enable the operator to halt the clock altogether, advance the seconds counter rapidly, advance the minutes counter rapidly, or light the led display momentarily when operating on battery.

*Mfr: Sparta Electronics Corp.*

*Price: \$475 (with reset board) Net joint board: \$100. Oscillator/battery backup board: \$125.*

*Circle 46 on Reader Service Card*



## We've been hiding our light under a bushel —

### ● C1616/C2424 CONSOLE

A year ago we studied the other two low cost recording consoles and we built a unit without their shortcomings. We also put in a few extra goodies, like semi-parametric equalizers on each input. We have installations in Atlanta, Washington, Wilkes-Barre, Denver, Lancaster, and more coming. Compare before you buy your new console. Circle 15 on Reader Service Card.

### ● MOM'S WHOLESOME AUDIO MICROMIXER

If you're into PA or stereo recording requiring lots of inputs with EQ and reverb, you might want to look into our MicroMixer. Circle 16 on Reader Service Card.

### ● ORTOFON DISC CUTTING EQUIPMENT

With installations in Nashville and Chicago, Ortofon has really got their thing together. Write or call for more information.

### ● SCHOEPS MICROPHONES

We've got some new hand held condenser microphones — both cardioid and omni patterns — that are absolutely pop free. Circle 17 on Reader Service Card.

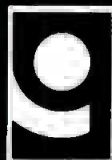

**GATELY ELECTRONICS, Inc.**

57 West Hillcrest Ave.  
Havertown, Penna. 19083  
215-449-6400

1907 Division St.  
Nashville, Tenn. 37203  
615-327-1746

*Circle 19 on Reader Service Card*



## WORAM AUDIO ASSOCIATES

Consultants in Studio Systems  
Engineering, Design and Installation

—offering—

A COMPLETE CONSULTATION  
SERVICE FOR STUDIO  
PLANNING AND  
CONSTRUCTION

FREE-LANCE RECORDING  
SERVICE IN THE  
NEW YORK AREA

212 673-9110  
64 University Place  
New York, N.Y. 10003



## RUGGED!

The BOSE name and a full FIVE YEAR WARRANTY are your assurances of reliability and performance with the BOSE 1800™ Professional Power Amplifier.

- 800 Watts rms
- LED Displays
- Over 1,300 Square Inches of Heat Sinks
- Sturdy Packaging
- Rack Mountable

Please send complete information on the BOSE 1800 to:

Name \_\_\_\_\_

Address \_\_\_\_\_

City \_\_\_\_\_ State \_\_\_\_\_ Zip \_\_\_\_\_

Mail to: BOSE, Dept. DP,  
The Mountain, Framingham, Mass. 01701

Circle 17 on Reader Service Card

## UNIQUE WOOFER

● A full range two way loudspeaker system, model L-500A, incorporates a unique woofer with cone material which is stiff, enabling it to move like a piston at bass frequencies, yet is soft and self-damping at high frequencies to prevent cone breakup. It also incorporates a soft suspension so that it has a low resonant frequency and can move with high efficiency and accuracy. Coupled with this woofer is a one-inch diameter soft-dome tweeter that weighs 0.2 grams and operates in a magnetic field of 15,000 Gauss. It is claimed that break-up is prevented by suspending the tissue dome by its own sealed acoustic chamber and by damping out resonances with damping fluid. Available in walnut or white.

Mfr: Braun (Distributor: Analog + Digital Systems, Inc.)

Price: \$129

Circle 47 on Reader Service Card



## CUSTOM CONSOLES

● Several new versions of the Centurion series custom consoles are being offered, a monaural 12-mixer version (Centurion I), a 6-mixer stereo (Centurion IV) and a 6-mixer mono (Centurion III). These new models join Centurion II, the stereo (quadriphonic capable) 12-mixer version. Six-mixer mono or stereo extender panels have also been devised for the series, giving up to 18-mixer capacity in a single system. Available options in all models include slide or rotary attenuators, interchangeable mixer modules, digital clock, etc. The consoles feature electronic pushbutton switching, motherboard-type construction, and replaceable or additional mixer modules.

Mfr: Sparta Electronic Corp.

Circle 48 on Reader Service Card

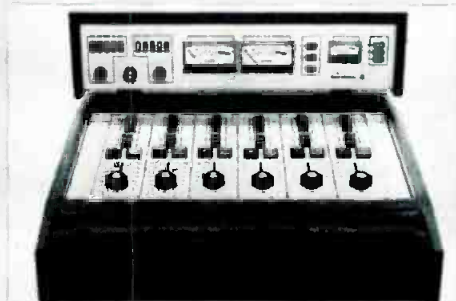

## CLAMP METER

● Volts, amps, and resistance can be measured by models 300/600 and 1200 clamp meters. The meter is clamped around one conductor and the current read on the graduated scale. Current ranges to 1200A, voltage ranges to 600V, and resistance measurements to 5,000 ohms are standard. The clamp meter also comes equipped with lead wires for voltage measurements, a special adaptor for resistance measurement, and a carrying case. Model 300/600 measures wire sizes to 1.02 diameter and model 1200 measures wire sizes to 1.889 diameter. Mfr: Panasonic (Matsushita Electric Corp. of America)

Circle 49 on Reader Service Card



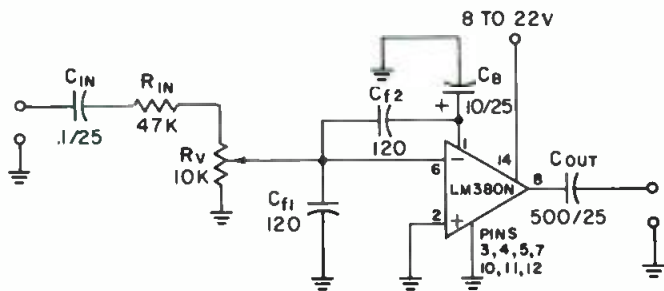

Figure 1. A general purpose monitor amplifier.

phones properly adjusted, it was only a matter of turning the recorder input controls to calibrate them to the headphones.

Since I spend considerable time testing for noise, distortion, and response in our studios, my reaction was predictable—this was a particularly ignorant procedure to be used by a supposed professional. On reflection, though, I had to admit that he was probably doing his best to work with what he had. After all, his job was to produce sound—not vu's. And while meters make a useful tool, the only meaningful way to evaluate the final product was to listen. So I decided to work on the headphone levels. (Just in case ignorance *was* involved, I gave my views on overdriving equipment—he seemed more interested in the prospect of turning up the phones, however.)

Since any amplifier purchased or designed for this problem would have to be applicable to all four of our audio consoles and several remote setups, I decided on a general approach. The ideal amplifier would have the following features:

1. High input impedance—to prevent circuit loading. The ubiquitous headphone jack is usually bridged across the line to be monitored and requires high impedance phones.
2. Ability to drive a wide range of headphone impedances—which means that the circuit must have a low output impedance.
3. Ability to drive small speakers—for remote applications and cueing.
4. Floating input—for bridging balanced or unbalanced lines.
5. Low current drain, wide supply voltage range—the unit should be able to tap existing power supplies and be capable of battery operation.
6. High quality—since we're producing a quality product, the monitor should reflect these standards with wide frequency response, low distortion and noise, etc.

Commercial units to meet these specifications are readily available—but unlimited budgets are not. Besides their prohibitive cost, most of the units were supplied as cir-

cuit cards and chassis which had to be wired and constructed anyway. On the other hand, the circuit of FIGURE 1 requires less construction than some of the commercial units, yet fits the bill rather nicely. Its cost is low and, with quality components, it is trouble free. The complete amplifier may be mounted in a variety of enclosures from the inside of existing equipment to a small construction box. The potentiometer and the input/output jacks are the limiting factor since the rest of the circuit fits comfortably on a 1½ inch square circuit board.

The LM380N is an integrated circuit manufactured by National Semiconductor. It will deliver 2.5 watts to a speaker, sports a low 0.2 percent distortion, flat frequency response from 0 to 100 kHz, an input impedance of 150 kilohms, and a voltage gain of 50. Voltage required is 8 to 22 Vd.c., and only 7 mA quiescent current is drawn. All in all, this makes a nice starting point for a general-purpose amplifier.

The i.c. is supplied in a standard dual-in-line package, 14 pins. The center three pins on either side comprise a heat sink and should be soldered to a square of grounded copper foil 1½ x 1½ inches for proper device dissipation at full power. However, for driving headphones and small speakers, no heat sinking is required and these pins may be merely grounded.

Input considerations are fundamental. Since the voltage gain of the i.c. is fixed at 50, it is only necessary to attenuate the input voltage for the desired output gain. In FIGURE 1, voltage attenuation (with the control at maxi-

imum) is approximately equal to  $\frac{R_v}{R_{in} + R_v}$  (the 150k

i.c. impedance shunted across  $R_v$  may be ignored, for  $R_v = 10$  k, but for larger control resistors, the shunt value of  $R_v$  and 150 k should be substituted for  $R_v$  in the expression). This yields an attenuation of 1/5 (or close enough with the standard values used) times a fixed gain of 50, for an overall voltage gain of 10. This will prove adequate for most applications.

FIGURE 2 shows alternate input arrangements. The network of 2(A) may be used when input impedance must be high. With  $R_v$  at 2.5 megohms, the input impedance of the amplifier will be approximately  $R_{in} + 75$  k (worst case). If maximum sensitivity is needed,  $R_{in}$  may be eliminated. FIGURE 2(B) illustrates a balanced input with the volume controlled by a single pot. Input impedance is a minimum of  $2 \times R_{in}$ . All amplifiers are shown as inverters, but reversing the pins 6 and 2 will result in non-inverted outputs. Either pin may be referenced directly to ground without regard for the offset compensation normally demanded by differential inputs.

$C_{in}$  (FIGURE 1) in addition to providing d.c. isolation, is used to roll off low frequencies. Our automated radio station uses 20 and 25 Hz control tones which drive monitors into distortion if not attenuated. The 0.1  $\mu$ F capacitor provides a gentle rolloff with the 3 dB point between 35 and 40 Hz. For more critical listeners who aren't bothered by this particular problem, the input capacitor may be eliminated if fed from a d.c.-isolated circuit (across a program line, at a monitor jack, etc.). If d.c. isolation is needed, the cutoff may be lowered by using a larger cap or increasing  $R_{in}$  (and  $R_v$  proportionately). Since a doubling of either value will halve the 3 dB cutoff frequency, calculations are simplified.

To minimize the effects of our a.m. transmitter, capacitor  $C_{f1}$  was shunted across the input to ground. In the breadboard stage, this value was 270 pF, but it was found that rf signal strength was sufficient to back-bias the emitter-base junctions of the input stages (see FIGURE 3, i.c. schematic). A high-frequency capacitor  $C_{f2}$  from the input to pin 1 eliminates this problem, but now two shunts

Figure 2. Alternate input arrangements. At (A) is the circuit for maximum input impedance while at (B) a conventional balanced input is shown.

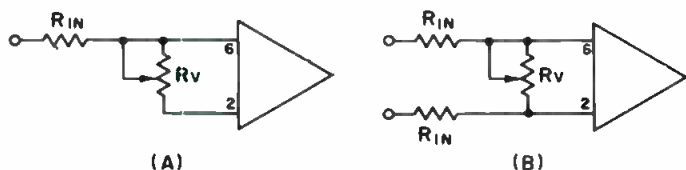

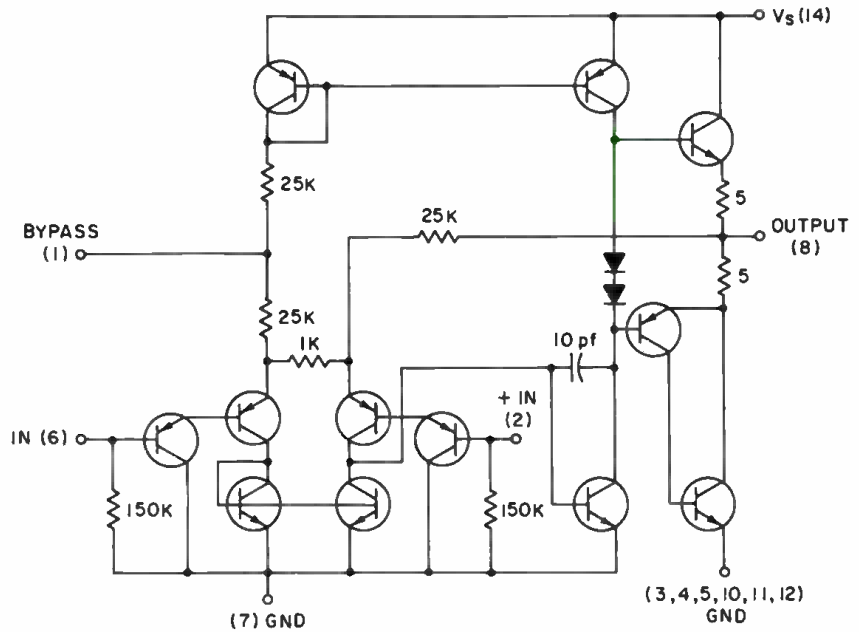

Figure 3. The schematic of the integrated circuit.

pass the audio to ground ( $C_{f1}$  and the series value of  $C_{f2}$  and  $C_b$ ), so values have to be halved. The value of these capacitors is non-critical except that a significant increase will begin to attenuate the audible high frequency response. Values shown maintain response to above 30 kHz.

Output impedance of this amplifier is unmeasurably low, making it suitable to drive any load. The output capacitor is made large to maintain bass response when driving low impedance loads.\* The d.c. voltage at output pin 8 is one half of the supply voltage, but the voltage rating of the capacitor should be equal to the supply for absolute protection.

A handy feature of this i.c. is the provision at pin 1 for a power supply decoupling capacitor. A small value electrolytic (or even a large value disc) eliminates any audible problem from the power source. With just 5 mF from pin 1 to ground, 60 Hz hum is rejected 30 dB and 120 Hz (and higher frequencies) are rejected 40 dB. Although this capacitor is not strictly needed with an adequate power supply, it is strongly recommended—especially if more than one amplifier shares the same supply.

This amplifier works best when powered as close to its 22 V maximum as possible, since maximum output before distortion is then possible. In practice, though, this circuit has been powered by a nine-volt battery with no audible difference. For fixed installations in existing equipment, it should be possible to tap into an existing 8 to 20 volt supply since the current drain is low.

Because of the nearly ideal characteristics of this circuit, it can be applied to a variety of purposes in addition to monitoring. As shown in FIGURE 1, it makes a handy line driver when coupled through a transformer. To eliminate some of the response problems associated with transformers, a series buildout resistor may be used to match the primary impedance as in FIGURE 4(A). Often, the only way to eliminate transformer related problems is to

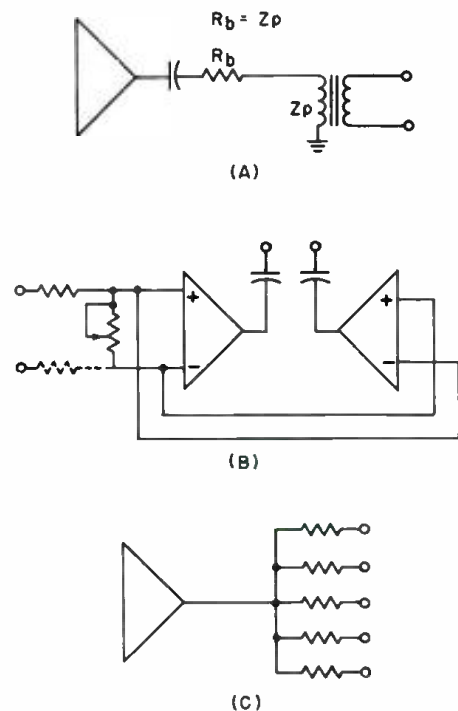

Figure 4. At (A) is the series buildout resistor used to match the primary impedance, at (B) are two i.c.'s in a bridge configuration, and at (C) advantage is taken of low output impedance to create a distribution amplifier.

get rid of the transformer. FIGURE 4(B) shows two i.c.'s in a bridge configuration which will drive a balanced load. In FIGURE 4(C), advantage is taken of the low output impedance to construct a distribution amplifier. The buildout resistors match impedances to the loads driven and isolate the various lines.

This amplifier should prove to be a versatile tool for the audio professional. It is inexpensive enough to be used for those trivial applications, yet transparent enough to be used even in demanding studio applications. ■

\*Manufacturer's data notes that oscillations may occur under some load conditions (when used to drive speakers) which may be corrected by adding a 2.7 ohm resistor and a 0.1  $\mu$ F capacitor in series from pin 8 to ground. I have not experienced any problem with such oscillations, however.

# Proud of your TV picture!

The new Burwen Dynamic Noise Filter gives audio to match . . .

Now you can broadcast film and video tapes with little or no distortion, full dynamic range and very low noise.

When installed in your broadcast chain, the Dynamic Noise Filter will reduce the cumulative noise from all sources preceding it 10-11 dB with no audible effect on the music or speech. This is accomplished with no less than 40 operational amplifiers and other precision components which provide 100 dB dynamic range with high accuracy, flat response over the entire range.

For complete details, call or write

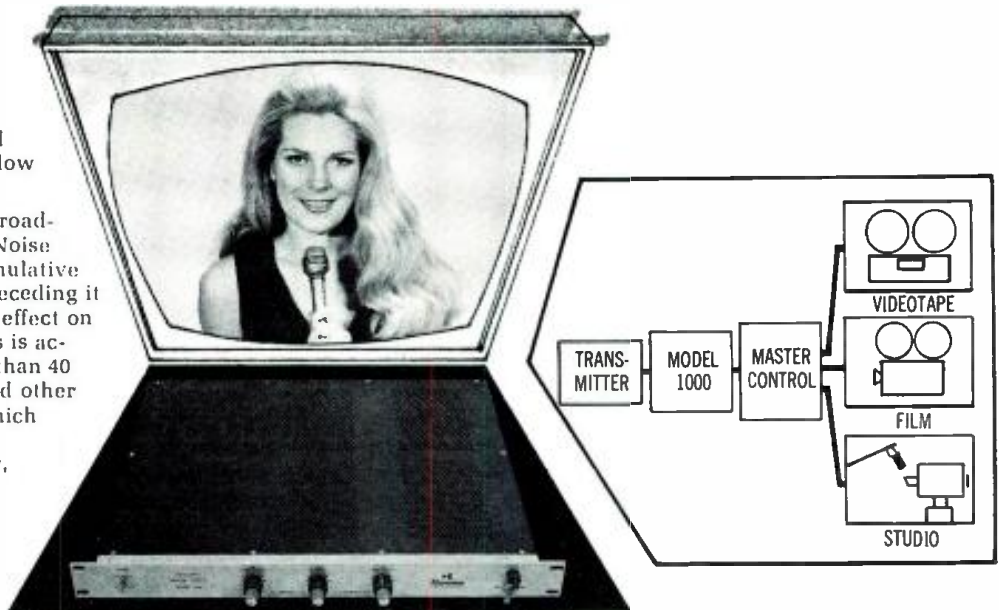

**Burwen**  
LABORATORIES, INC.

209 MIDDLESEX TURNPIKE, BURLINGTON, MA. 01803/TEL. (617) 273-1488

Circle 28 on Reader Service Card

What you need is a console that works when you get it.

That's the  
**"Son of 36 Grand"**



**auditronics, inc.**

P. O. Box 12637  
Memphis, Tenn. 38112  
(901) 276-6338

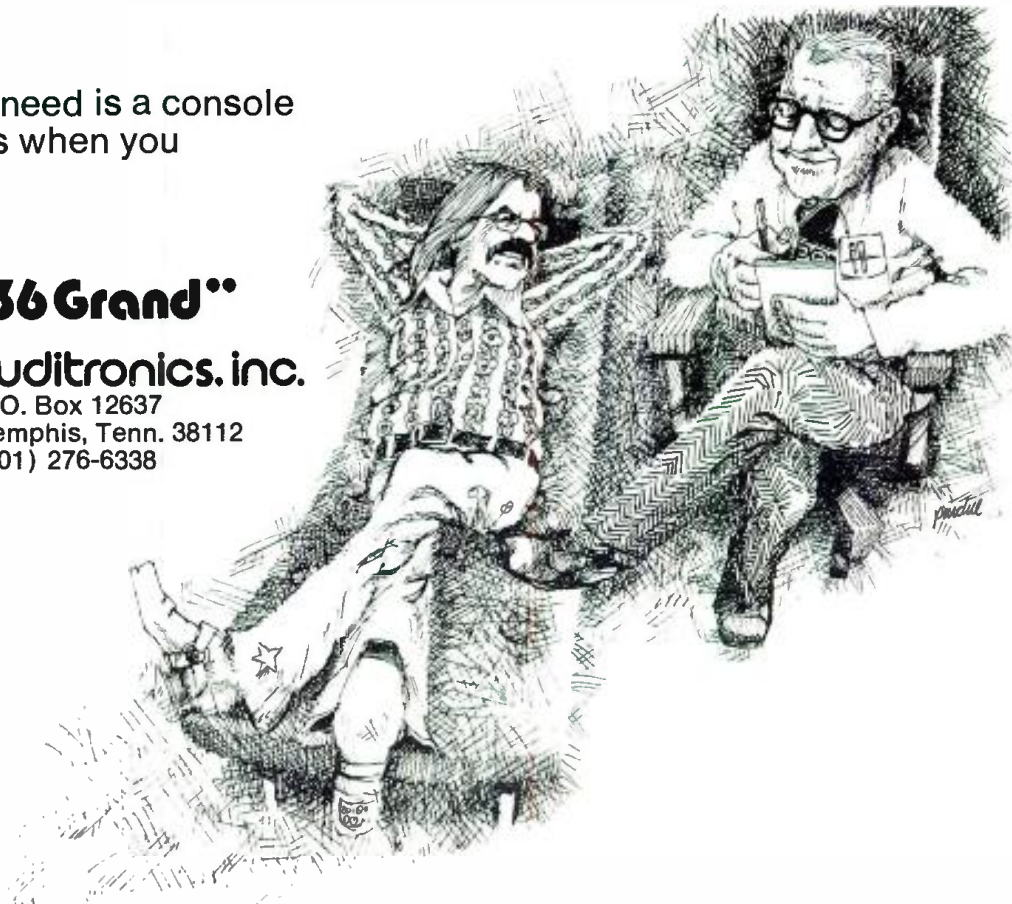

Circle 14 on Reader Service Card

# The Decibel: Basics, part I

*The decibel is too often taken for granted as to its meaning, and just as often the thought is wrong. The author takes you through the uses of the decibel and the mathematics behind the usage. Part 2 next month will conclude this basic guide to the dB.*

- 60 dB below 1 mW per 10 microbars signal at 200 ohms
- 54 dB below 1 volt/dyne/cm<sup>2</sup>
- 8 dBm
- Minus 4 vu

**D**O THESE STATEMENTS mean something specific to you? Perhaps not; if you are an audio neophyte your understanding of dB, dBm and vu may be still somewhat hazy. Well, don't be discouraged, let's just take time out to unveil the mystery surrounding the decibel.

It is important that this haze be cleared away because as you have probably already found out, a reference to "dB" occurs quite often in audio and electronic literature. It is the basic unit regularly used today by audio engineers and technicians for measuring and comparing sound levels and intensities. As you progress in audio, television, radio or any electronically oriented field, you will find the decibel used to specify the performance of antennae, amplifiers, attenuators, filters, microphones, transformers and a host of other equipment and components. Consequently, an early understanding of the decibel may possibly eliminate substantial confusion later on.

For our discourse it will behoove us to clarify some audio terminology and physical relationships as they are attributed to audio measurement.

To begin with, when an audio response is registered in the human brain, it is due to the fact that a force has acted upon some unit (piano string, valve, etc.) causing

that unit to vibrate. The vibrating unit in turn disturbs the air molecules in accord with its vibrations. When the movement of the air molecules is at, or above, a definite speed or velocity at the time they impinge upon the ear drum, we experience the sensation of sound.

The physicists' basic unit of force in the centimeter-gram-second system is the *dyne*. The classical definition of the dyne is "the force, which acting upon one gram of matter, will give it an acceleration of one centimeter per second for every second the force acts." Practically speaking, the force of one dyne is approximately equivalent to the weight of a small size postage stamp.

In audio work, where we use devices upon which force or pressure is distributed over a given area, such as the diaphragm of a microphone, an ear drum, or the cone of a speaker, we find that "sound pressure" is a conveniently descriptive term. "Dyne per square centimeter" (or that force approx. equal to the weight of a postage stamp acting upon an area 0.155 square inches) is defined as the basic unit of sound pressure. Measurement shows that 0.000204 dynes (a force two ten thousandths the weight of a postage stamp) per square centimeter is the least sound pressure discernible by the human ear.

The ear is constantly under pressure of the surrounding

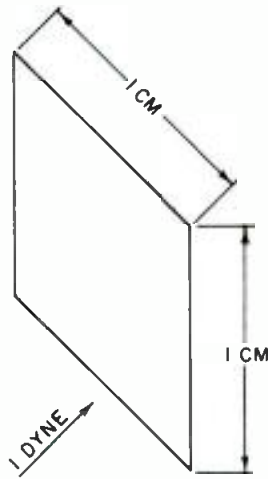

One dyne.

atmosphere. Consequently, any sudden variation (air-molecular velocity movement) of the ambient atmospheric pressure produces sound.

Atmospheric pressure is measured in terms called *microbars*, one microbar being approximately equal to one-millionth of the normal atmospheric pressure. This, in turn, is equal to our dyne per square centimeter. Since one microbar equals one dyne per square centimeter, it follows that one bar equals one million dynes per square centimeter. (Note that normal atmospheric pressure equals 1,013,250 microbars.)

This brings on to our last audio term which is an expression of sound intensity, known as *watts per square centimeter*.

A loudspeaker produces sound pressure vibrations, as does a tuning fork or piano string. The magnitude or intensity of the molecular air movement depends upon the energy imparted due to the work produced. In other words, sound intensity depends upon sound energy. The expression for sound intensity in air when we relate it to electric power, is "watts per square centimeter." At the threshold of hearing (or zero dB) the transmitted sound produces  $10^{-16}$  watts of energy to each square centimeter of the ear.

But hearing, like all human sensory perception, is non-linear. That is to say, a physiological response such as hearing, sight or pain is not directly proportional to stimuli, such as sound, light, or pinch.

For example, if you light a candle in a dark room your eyes will respond to the light, transmit the stimulus to your brain, which registers one candle light. If now you wish to double the light in the room, you must light another candle, thus producing two-candle light. If we again decide to double the room light, we must light two more candles, giving us a total of four candles for the second increase. If we decide a third time (1, 2, 3-arithmetic progression) to double (2x) the existing light (eye response) we must add four lighted candles (units of stimuli).

Notice that the change in response is uniform, 1-2-3-4 . . . . ., but the unit quantity of stimulus is doubled each time, 1-2-4-8-16-32. Stimulus increases in accord with the following progression:

Stimulus =  $S^0 + S^1 + S^2 + S^3 + S^4 \dots$   
 Since response is to be doubled,  $S = 2$   
 Then  $2^0 + 2^1 + 2^2 + 2^3 + 2^4 =$  geometric progression  
 Where 0 1 2 3 4 = change in response  
 And  $1 + 2 + 4 + 8 + 16 =$  unit quantity of stimulus  
 The above is a geometric progression which registers upon our senses as an arithmetical series. A system of mathematics which provides this conversion automatically is called *logarithmic*. The decibel, as we shall see, is a form of logarithm.

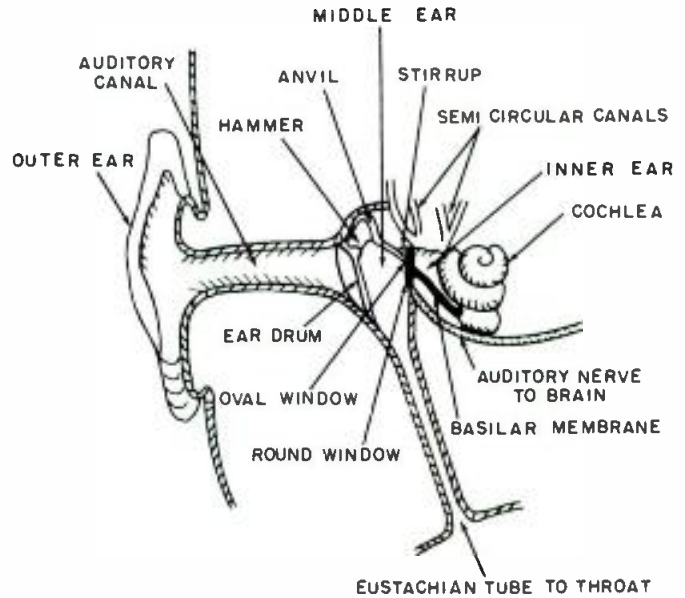

Figure 1. The internal construction of the human ear.

The ear, like the eye (and candle light) is a human sensory organ whose audio response is naturally non-linear. The total ear comprises a system, the function of which is to transmit vibrations to the brain. One of the major links in this transmission train is called the *cochlea*, a spiral tube filled with fluid. Vibrations are transmitted by the fluid to nerve endings along the basilar membrane and thence to the brain.

So, as we can see from FIGURE 1, air vibrations enter the outer ear, stimulate the anvil and hammer of the middle ear, which acts as a transducer to change air vibrations to fluid vibrations in the inner ear.

The degree of auditory response is therefore determined by the intensity of fluid vibrations in the inner ear; these vibrations are proportional to the *logarithm* of the loudness rather than directly to the loudness.

So far we have twice made reference to logarithms. Therefore, we shall now review the basic principles involved in the mathematics of logs.

First of all let us realize that log, like plus or minus, is mathematical language indicating what operation is to be performed. When the subject under consideration is exponents, then the mathematical terminology is logarithm.

If we take any number N and multiply it by itself, we say that N is taken as a factor twice. The product of  $N \times N$  is called the square of N and is expressed as  $N^2$ . If N is taken as a factor three times, the product of  $N \times N \times N$  is called the cube of N.

Example 1: Let  $N = 10$   
 $10 \times 10 = 10^2 = 100$   
 $10 \times 10 \times 10 = 10^3 = 1000$

In the language of logarithms, the number N used as the factor is called the *base*. The number of times N is multiplied by itself or taken as a factor is called the *power* and is indicated above and to the right of the base number. This power indicator is called an *exponent*.

Consider the following:

10	=	$10 \times 1$		Log 10	=	1	
100	=	$10 \times 10$	=	$10^2$ :	Log 100	=	2
1000	=	$10 \times 10 \times 10$	=	$10^3$ :	Log 1000	=	3
10,000	=	$10 \times 10 \times 10 \times 10$	=	$10^4$ :	Log 10000	=	4

Note that each succeeding number in the above series is a multiplication of ten times the preceding number and

can be expressed by the integer 10 raised to the next numerical power. Consequently, it must be realized that the log (or exponent) to the base 10 of a number between 100 and 1000 lies between 2.0 and 3.0

TABLE 1

A SHORT TABLE OF LOGARITHMS

N	1	N	1	N	1
1.0	.0000	4.1	.6128	7.2	.8573
1.1	.0414	4.2	.6232	7.3	.8633
1.2	.0792	4.3	.6335	7.4	.8692
1.3	.1139	4.4	.6435	7.5	.8751
1.4	.1461	4.5	.6532	7.6	.8808
1.5	.1761	4.6	.6628	7.7	.8865
1.6	.2041	4.7	.6721	7.8	.8921
1.7	.2304	4.8	.6812	7.9	.8976
1.8	.2553	4.9	.6902	8.0	.9031
1.9	.2788	5.0	.6990	8.1	.9085
2.0	.3010	5.1	.7076	8.2	.9138
2.1	.3222	5.2	.7160	8.3	.9191
2.2	.3424	5.3	.7243	8.4	.9243
2.3	.3617	5.4	.7324	8.5	.9294
2.4	.3802	5.5	.7404	8.6	.9345
2.5	.3979	5.6	.7482	8.7	.9395
2.6	.4150	5.7	.7559	8.8	.9445
2.7	.4314	5.8	.7634	8.9	.9494
2.8	.4472	5.9	.7709	9.0	.9542
2.9	.4624	6.0	.7782	9.1	.9590
3.0	.4771	6.1	.7853	9.2	.9638
3.1	.4914	6.2	.7924	9.3	.9685
3.2	.5051	6.3	.7993	9.4	.9731
3.3	.5185	6.4	.8062	9.5	.9777
3.4	.5315	6.5	.8129	9.6	.9823
3.5	.5441	6.6	.8195	9.7	.9868
3.6	.5563	6.7	.8261	9.8	.9912
3.7	.5682	6.8	.8325	9.9	.9956
3.8	.5798	6.9	.8388	10.0	1.0000
3.9	.5911	7.0	.8451		
4.0	.6021	7.1	.8513		

As we progress, we realize that the idea of logarithms is basically an extended system of the powers of 10. If we express a number, 76,090, in the power of ten form, we have  $7.6090 \times 10^4$ . Considering that every number can be expressed as ten raised to a power, refer to TABLE 1, which is a short listing of logarithms (or numbers with their exponents which to the base ten is equivalent to that number). Finding 7.6, which is as close in accuracy as this table permits, we read the exponent (or log) .8808. This means that the number 7.6 can also be expressed as  $10^{0.8808}$ . Therefore, to find the log of the number 76,090 we first express it as a number between 1 and 10 multiplied by the proper power of ten ( $7.6090 \times 10^4$ ). Next, by using a slide rule or a table of logarithms, we express the resulting number (1-9) as a power of ten. (Note:  $10^0 = 1$  and  $10^1 = 10$ ). Thus  $7.6090 = 10^{0.8808}$  and since the base 10 is understood in all common logarithms calculations we can omit writing it, we then have  $7.6090 = 0.8808$ . Since one of the time saving tenets of logarithms permits us to add exponents, our number can be written as  $76,090 = 10^4 \times 10^{0.8808} = 10^{4.8808}$ . Converting to logs, we omit writing the 10 and thus we have  $\log 76,090 = 4.8808$ .

As you can see, the logarithm consists of two parts, the number before the decimal, which is called the *characteristic*, and the portion after the decimal, called the *mantissa*. The characteristic is the power of ten when the numerical expression is reduced to a number between one and nine times ten to a power. The mantissa is the power of ten of the reduced numerical expression. Note that the characteristic is calculated from the number of digits before or after the decimal point in the expression.

TABLE 2

Number	Power of Ten	Characteristic
.0001	$10^{-4}$	-4
.001	$10^{-3}$	-3
.01	$10^{-2}$	-2
.1	$10^{-1}$	-1
1.	$10^0$	0
10.	$10^1$	1
100.	$10^2$	2
1000.	$10^3$	3
10000.	$10^4$	4
100000.	$10^5$	5
1000000.	$10^6$	6
1,760,000	$1.76 \times 10^6$	6

Therefore, to find the logarithm of a number, two steps are involved. First, find the characteristic by rewriting the expression as a power of ten, then remembering that  $10^0$  equals 1 and  $10^1$  equals 10, find the power of ten, or mantissa, of the remaining number part by using the slide rule or log table. The logarithm of the original number is the sum of the two parts, characteristic and mantissa. The mantissa, being a number between 0 and 1, (from  $10^0$  and  $10^1$ ) is always a decimal and is always positive.

- Example 1:  $76.0 = 7.60 \times 10^1$ : characteristic = 1  
 $7.60 = .8808$  (from TABLE 1):  $\log 76.0 = 1.8808$
- Example 2:  $7,609 = 7.609 \times 10^3$ : characteristic = 3  
 $\log 7609 = 3.8808$
- Example 3:  $760,900 = 7.60900 \times 10^5$ :  
characteristic = 5  
 $\log 760,900 = 5.8808$
- Example 4:  $\log .007609 = 7.609 \times 10^{-3}$ :  
characteristic = -3  
 $\log .007609 = -3.8808$

The reverse action to finding the logarithm is calculating the *antilog*. That is, finding the number when the logarithm is known. This procedure is also carried out in two steps. First, let us remember that if the logarithm is between 0 and 1 then the antilog must be a number between 1 and 10. Such antilogs can be found directly from a slide rule or table of logarithms. Next, for a logarithm greater than one, the characteristic indicates the power of ten by which the antilog of the mantissa must be multiplied to obtain the original number.

- Example 5:  $\log 3.8088$  Find antilog.  
Antilog 3.8808:  
characteristic = 3 =  $10^3$   
mantissa .8808 = 7.609  
antilog =  $10^3 \times 7.609 = 7,609$

This resumé on logarithms was necessary because the decibel is actually a logarithmic ratio. Furthermore, logarithmic (decibel) notation readily lends itself to the extremely wide range of measurement required for audio. From the whisper of a summer breeze to the roar at the muzzle of a 9 inch gun is a range not easily noted or readily perceived.

Figure 2. The equivalent circuit of a transmission line.

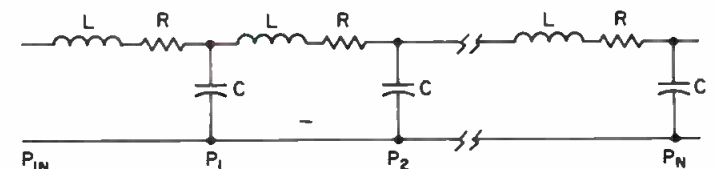



### RELATIVE INTENSITIES OF DIFFERENT NOISE LEVELS

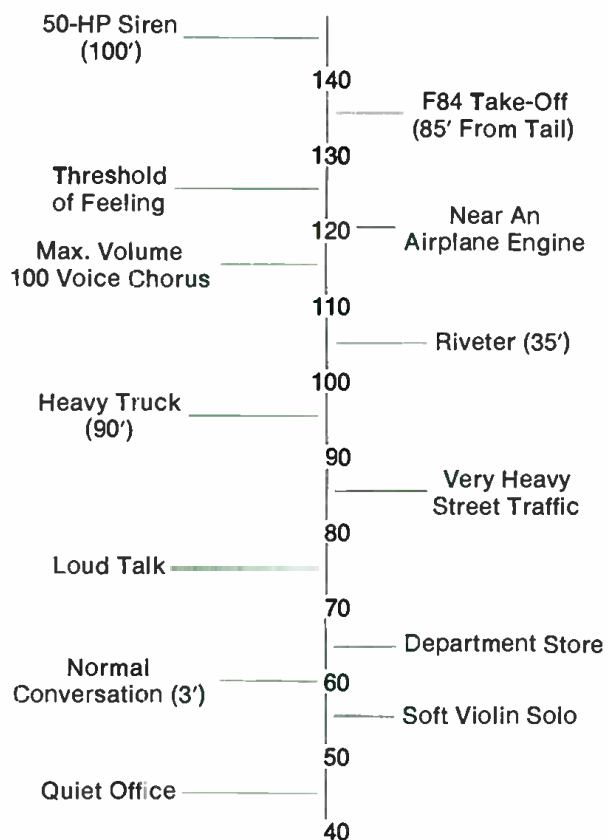

The equivalent circuit of a transmission line is represented in FIGURE 2. It indicates that a transmission line consists of equal sections, each of which presents an equivalent power loss to a line signal. From FIGURE 2 we see that  $P_{in}$  represents the input power and  $P_1$  represents the power input minus a unit of power lost. Similarly,  $P_2 - P_1$  equals the power at  $P_2$  minus a second unit of power loss.

Mathematically speaking, we have:

$$\begin{aligned} P_1/P_{in} &= K \\ P_1 &= KP_{in} \\ P_2 &= KP_1 = K \cdot KP_{in} = K^2P_{in} \\ P_N &= K^N P_{in} \\ K^N &= P_N/P_{in} \end{aligned}$$

Taking log of  
both sides:

$$\begin{aligned} N \log K &= \log P_N/P_{in} \\ N \log P_1/P_{in} &= \log P_N/P_{in} \\ & \text{(Substituting } K = P_1/P_{in} \text{)} \end{aligned}$$

Which means that the total line loss,  $P_N/P_{in}$  can be calculated by multiplying the number of line sections  $N$  by the logarithm of the power ratio.

If we consider the power loss in a one mile section of specified telephone cable, we can define this loss as one *transmission unit*, as telephone engineers did many years ago. We now have a basis for expressing attenuation (minus) or gain (plus) in all types (passive and active) of audio equipment. For example, the loss thru a pad could be equivalent to six miles of "standard cable" or as the old telephone engineer would say, minus 6 tu's.

## Our Professional Preamplifier



Some typical specifications are:

- Dynamic Range: Greater than 130 dB
- THD: Less than .005% at 1kHz (+18 dBm/600 ohms)
- Weston meters with Burwen Laboratories VU306 electronics modules switchable for VU or peak characteristics
- Peak reading characteristics include:
  - Peak response in 5 microseconds
  - Holds peaks for two seconds
  - High frequency pre-emphasis position avoids tape saturation at slow speed taping
  - Accuracy of reading: 0.1 dB

- Channel Tracking Accuracy: 0.1 dB all functions, all conditions
- Dials read to high accuracy of dial setting, typically 0.1dB
- External power supply reduces hum and noise pickup
- Teflon insulated coaxial leads for all audio circuits
- Switchcraft 3-pin connectors in parallel with phono plugs to facilitate interface of studio with consumer equipment
- Switchable gain allows maximum S/N ratio for wide range of input levels 0 to 40 dB in 10 dB steps

Price: \$1750.

**MARK LEVINSON** audio systems

21 carriage drive, woodbridge, conn. 06525, u.s.a. • (203) 393-2600

Circle 33 on Reader Service Card

In later years, it was agreed between the broadcasting and telephone industries to define the power ratio as equal to ten, and name the quantity the "Bel" after Alexander Graham Bell, inventor of the telephone.

$$\text{Let } P_1/P_{in} = 10$$

$$\text{Then } \text{Log } P_1/P_{in} = 1 \text{ Bel}$$

However, practical experience proved the bel as too large a unit, so it was divided by ten to become the more common unit of measurement known as the *decibel*. This unit is practically equal to the original "standard mile."

So . . . 1.1

Equation 1.1:  $\text{decibel (dB)} = 10 \text{ Log}_{10} P_1/P_2$   
 where dB equals the number of decibels and  $P_1$  and  $P_2$  are respectively the output and input powers, or,  $P_2$  is a reference power to which  $P_1$  is being compared.

Equation 1.1 simply says that the number of dB is equal to ten times the number of ten factors in the ratio of output power to input power.

Power Ratio	No. of 10 Factors	No. of Bels	No. of Decibels
1,000,000	$10^6$	6	60
100,000	$10^5$	5	50
10,000	$10^4$	4	40
1,000	$10^3$	3	30
100	$10^2$	2	20
10	$10^1$	1	10

Notice that the decibel is not a direct measurement such as the pound, mile or second. It is simply a measure of changes in power coincident with the natural ability of the human ear to perceive these changes. It is strictly a relative measurement, depending not only upon the amount of change, but also upon the original sound intensity.

If an amplifier delivers a pure tone at two watts and we wish to double the apparent sound level or loudness, the power level would have to be squared. If we increased the sound level five times ( $2^5 = 32$ ) the acoustic power would have to be increased by 30 watts (total power 32 watts). On the other hand, if we begin by listening to a six watt pure tone, then increase the power level by 30 watts (total power 36 watts) we have actually only doubled our apparent sound level— $6^2 = 36$ . In other words, a 30-watt power increase in one case increased the sound five times, while in the other case the same 30-watt drive only *doubled* the apparent sound level (loudness).

At this point, you have probably noticed or realized that, by changing the base, a single number can be expressed as more than one logarithm.

Example 6:  $\text{Log}_2 64 = 6$   
 $\text{Log}_4 64 = 3$   
 $\text{Log}_8 64 = 2$

However, to eliminate confusion and the overwhelming number of systems and log tables that would result, mathematicians have evolved two systems for general use. One is the *Naperian* or natural system which uses 2.71828 as its base; the other is the common, or *Briggs System* that uses ten as its base. The latter system is, of course, the one with which we are concerned.

Example 7a: 30 watt power increase  
 2 watts to 32 watts

$$\text{dB} = 10 \log 32/2$$

$$= 10 \log 16$$

$$= 10 \log 1.6 \times 10^1 \text{ (characteristics} = 1)$$

$$= 10 (1.225)$$

$$\text{dB} = 12.25$$

Example 7b: 6 watts input to an amplifier  
 36 watts output  
 $\text{dB} = 10 \log 36/6$   
 $= 10 \log 6 \text{ (characteristic} = 0)$   
 $= 10 (0.778)$   
 $\text{dB} = 7.78$

These examples further verify that the decibel is a relative measurement, depending on the amount of change as well as the original intensity.

Now, to truly understand the decibel one must basically recognize its dual concept:

1. Gain or loss measurements by comparing the power content of two signals.
2. Power rating of equipment as compared to a standard reference.

Consequently, referring back to equation 1.1, we should always consider  $P_2$  as the reference power to which  $P_1$  is being compared.

In considering the basic decibel application of measuring gain or loss it must be understood that an electrical component or network develops gain when its power output is greater than the power input. On the other hand, a loss is developed in an electrical network when its output power is less than the input power. For example, if a single dipole antenna is replaced by a parabolic antenna what is the power gain in dB directed toward the main station? A power amplifier has a rated output of 50 watts with an 0.5 watt input. What is the gain of the amplifier in dB? To solve these problems in terms of decibel gain or loss, we form a ratio of the powers involved, find the logarithm of that ratio and multiply by ten. If the component or network exhibits a loss, we indicate the loss with a minus sign in front of the decibel value. Therefore, if  $P_2$  is always the smaller power level, we can eliminate mathematical complications and use common sense to determine whether our dB value represents a gain or loss.

Example 8: An amplifier has an output of 3 watts when the input is 1 milliwatt.

Solution: A gain is realized since the output power is greater than the input power.

$$\text{Gain} = 3/.001 = 3000$$

To find gain in decibels, we take the logarithm of the power ratio and multiply by ten.

$$\text{Gain} = 10 \log 3000$$

$$= 10 \log 3 \times 10^3 \text{ (characteristic} = 3)$$

$$= 10 (3.477)$$

$$= 34.77$$

Example 9: A vestigial sideband filter is installed in a television transmitter. What is the insertion loss if the power output is reduced from 40 kW to 29 kW?

Solution: It is obvious that a loss developed; therefore, the answer should be preceded by a minus sign. Remember we always make the largest power the numerator.

$$\text{dB} = 10 \log P_1/P_2$$

$$= 10 \log 40/29$$

$$= 10 \log 1.38$$

$$= 10 (0.14)$$

$$= -1.4$$

In working with electronic equipment, one rarely takes power measurements nor does one usually have direct reading power measuring equipment handy. On the other hand a voltmeter is standard equipment and current, voltage, and resistance readings are usually easy to obtain.

Since power and voltage are related by:

$$P = E^2/Z \cos \theta$$

we can write our decibel equation as follows:

$$N_{dB} = 10 \log \frac{(E_1^2/Z_1) \cos \theta_1}{(E_2^2/Z_2) \cos \theta_2}$$

One rule of logarithms states: "The logarithm of a product is equal to the sum of the logarithms of the factors." Therefore, we can write:

$$N_{dB} = 10 \log (E_1/E_2)^2 + 10 \log Z_2/Z_1 + 10 \log \cos \theta_2 / \cos \theta_1$$

Another rule of logarithms states: "The logarithm of any power of a number is equal to the logarithm of the number multiplied by the exponent of the power." Therefore, we can write:

$$N_{dB} = 20 \log E_1/E_2 + 10 \log Z_2/Z_1 + 10 \log \cos \theta_2 / \cos \theta_1 \quad 1.2$$

Where  $E_1$  and  $E_2$  are the rms values of signal voltage with  $E_2$  being the reference voltage,  $Z_1$  and  $Z_2$  the impedances across which the associate voltages are measured,  $Z_2$  being the reference with  $\theta_1$  the angle of  $Z_1$  and  $\theta_2$  the angle of  $Z_2$ .

If we use current measurements in our analysis, we use the expression  $P = I^2Z \cos \theta$  in our original equation and we have:

$$N_{dB} = 20 \log I_1/I_2 + 10 \log Z_1/Z_2 + 10 \log \cos \theta_1 / \cos \theta_2 \quad 1.3$$

In this case  $I_1$  is the rms value of signal current;  $I_2$  the rms value of current to which  $I_1$  is being compared and the other parameters the same as described above.

Under most circumstances  $Z_1$  and  $Z_2$  are considered resistive. Thus, there is no operator to produce a phase shift between the voltage and current, so the power factor  $\cos \theta$  becomes unity. Since the log of 1 equals zero the cosine term drops out, and we have:

$$N_{dB} = 20 \log E_1/E_2 + 10 \log R_2/R_1 \quad 1.4$$

If the two resistances are of equal value, the resistive term drops out, and we have:

$$N_{dB} = 20 \log E_1/E_2 \quad 1.5$$

**Example 10:** The voltage to the first stage of an amplifier is 0.4 volts. When the level control is increased the voltage becomes 0.8 volts. What is the gain in dB?

$$\begin{aligned} \text{Solution: Gain} &= 20 \log V_1/V_2 \\ &= 20 \log .8/4 = 20 \log 2 \\ &= 20 (.3010) \\ &= 6 \text{ dB} \end{aligned}$$

**Example 11:** An a.m.-f.m. tuner delivers 0.2 volts to the 40 kilohm resistive input of an amplifier. The output is 10 volts across 8 ohms resistive. What is the gain in dB?

$$\begin{aligned} \text{Solution: Gain} &= 20 \log E_1/E_2 + 10 \log R_2/R_1 \\ &= 20 \log 10/0.2 + 10 \log 40,000/8 \\ &= 20 \log 50 + 10 \log 5000 \\ &= 20 (1.6990) + 10 (3.6990) \\ &= 33.9 + 36.9 \\ &= 70.8 \text{ dB} \end{aligned}$$

The second aspect of decibel notation is utilized for equipment specifications. It is common practice for manufacturers to express the power handling capabilities of their equipment in terms of dB. For example, an amplifier manufacturer may claim that the undistorted output power of his amplifier is 40 dB, while a microphone manufacturer may report that his Model X microphone is rated at -74 dB. (To be continued next month.) ■

**Solve YOUR Cleaning Problems...**

**4 Product TRIAL UNIT \$10<sup>00</sup>**

electronic components - tape heads - contacts

Economical MILLER-STEPHENSON aerosols take the headaches (and a lot of expense) out of what used to be a nuisance.



**MS-180 "FREON"™ TF DEGREASER** - No need to disassemble components. Spray MS-180 onto relays, circuit boards, motor parts. Removes dirt, dust, oil; prevents recontamination. Non-conductive, non-flammable. Reduces maintenance costs. Freon™ DuPont Trademark

**MS-200 MAGNETIC TAPE HEAD CLEANER** - Spray away oxide dust before it ruins heads and tapes. MS-200 flushes it away. Manufacturers recommend it; communications experts prescribe it; EDP operators wouldn't be without it. U.S. & FOREIGN PATS.

**MS-230 CONTACT RE-NU** - Renew your contacts. Re-Nu does it. Flush away dirt, carbon, and other "interferences." Will not harm insulation; leaves no residue. Switch to MS-230 for your switches - and other points.

**MS-226 "Cobra" EXTENSION NOZZLE/Solvent Spray Brush** - "Co-Brush" away stubborn dirt, carbon, grease, oxide build-up.

**ms miller-stephenson chemical co., inc.**

SE Danbury, Connecticut 06810 (203) 743-4447

- Enclosed is \$10.00, please send my "4-Product Trial Unit".
- Please send FREE literature and prices.

NAME \_\_\_\_\_ TITLE \_\_\_\_\_

DEPT. \_\_\_\_\_

COMPANY \_\_\_\_\_

ADDRESS \_\_\_\_\_

CITY \_\_\_\_\_ STATE \_\_\_\_\_ ZIP \_\_\_\_\_

CHICAGO • LOS ANGELES • TORONTO  Dist. in ITALY • GERMANY • FRANCE • ENGLAND • SCOTLAND • SPAIN • NETHERLANDS • LEBANON

Circle 25 on Reader Service Card

# db Visits—dbx

**Y**OU HARDLY GET airborne when leaving New York's LaGuardia Airport when you find you are touching down at Boston's Logan Airport. From there it is a short drive to the neat laboratories and manufacturing facility of dbx, Incorporated.

dbx, Incorporated has come a long way in a relatively short time. It was formed as a Massachusetts corporation in April, 1972 by David E. Blackmer and Zaki Abdun-Nabi. Both had previously worked together as instrumentation engineers at Ebsco during the late 1950's, working in precision telemetry equipment. Both subsequently left Ebsco to form new companies. Zaki-Abdun-Nabi left in 1963 to found Janus Control Corporation with which he remained as president until 1969. Janus had earlier become an acquisition of Tyco Laboratories and had been renamed the Tyco Instrument Division. (It is in the business of manufacturing numerical controls for the machine tool industry.)

David E. Blackmer became founder in 1960 of the Instrumentation Laboratory. He was vice president of research and development for some ten years before leaving to found dbx in 1971. During his active participation at Instrumentation Laboratory he was involved in the development of such products as blood gas analyzers, flame photometers, and atomic absorption spectrophotometers. He has some eighteen patents granted on electronics and instrumentation products. By the time he left Instrumentation Laboratory, the company had successfully gone public and had achieved an annual sales volume of over \$20 million.

Dave Blackmer's decision to found a company in the professional audio field did not come about by chance. He had worked in recording studios in the 1940's and had designed equipment for recording and broadcast applications.

The first product from the new company, issued in 1971, was the Model 81 dB meter, distinguished primarily by its ability to indicate an 80 dB dynamic range on a single unswitched scale. This product was followed by the Model 117 dynamic range enhancement device for restoring dynamic range to records, tapes and f.m. broadcasts, their first product for the consumer audio field. At the same time development work and first products appeared embodying the dbx professional noise reduction system, now gaining wide acceptance in the recording industry. Their latest achievement has been to have an independent record company, Klavier Records, issue stereo discs that have been dbx encoded. When played back through a decoder, the elimination of characteristic disc sound produces a tape-like quality.

dbx, Incorporated moved into its present quarters, 8500 square feet in a two-story brick building in May, 1972. This move was done with eight employees and big plans. That those plans are well founded is attested to by the fact that over sixty people are now employed and the company now has a product line of over thirty products in professional and consumer audio as well as OEM and industrial instrumentation. The company remains privately held. ■



*Research is an ongoing project at dbx. Here chief engineer C. Renee Jaeger does his thing.*



*This photo illustrates the use of a carousel to rotate the component to be assembled using circular assembly line with the construction done by one assembler.*

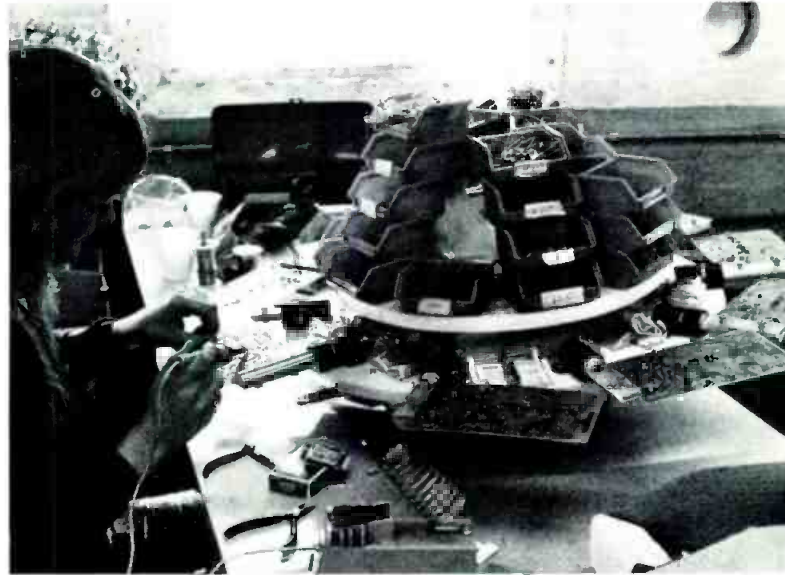

*The carousel concept is also used to present a variety of components to an assembler during the construction of a p.c. circuit.*

*Units are being completed at this station, while behind it, completed circuit boards are stored awaiting the production of the system for which they might be destined.*



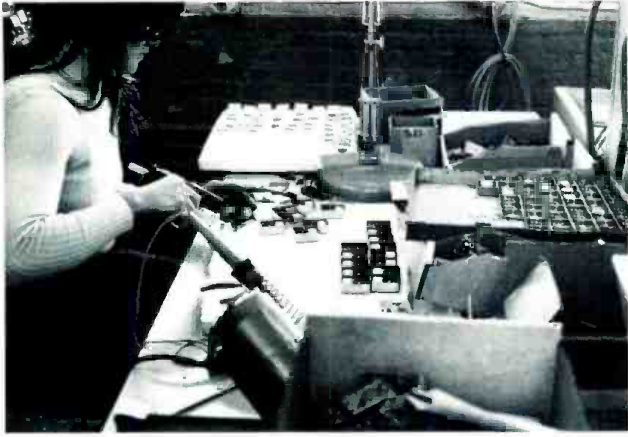

*Portions of the dbx system are preassembled into cans and potted at this station. This is the heart of the VCA used in the noise reduction system.*

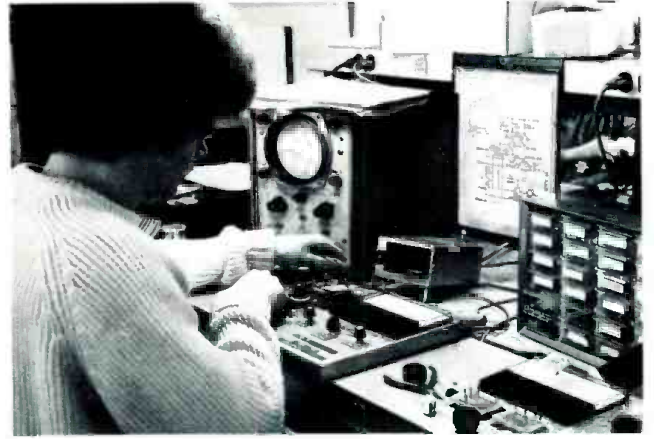

*Finished VCA modules are individually tested at this position. Testing is done before and after assembly into cans.*

*A line up of frames awaiting assembly into finished noise reduction systems. These frames accept slip in noise-reduction modules.*

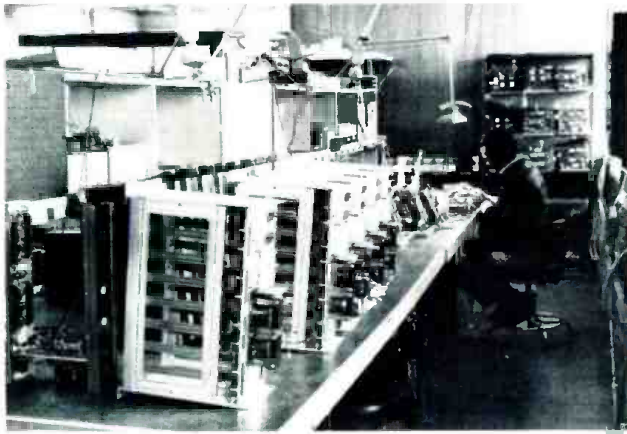

*A general view of the production area. You can see the heavy use of the carousel system which is much praised by dbx as both efficient and effective in reducing production defects.*



*Finished dbx noise reduction units at the end of the line share shelf space with circuit cards. As demand for the system continues to grow, dbx is finding it necessary to increase production steadily.*

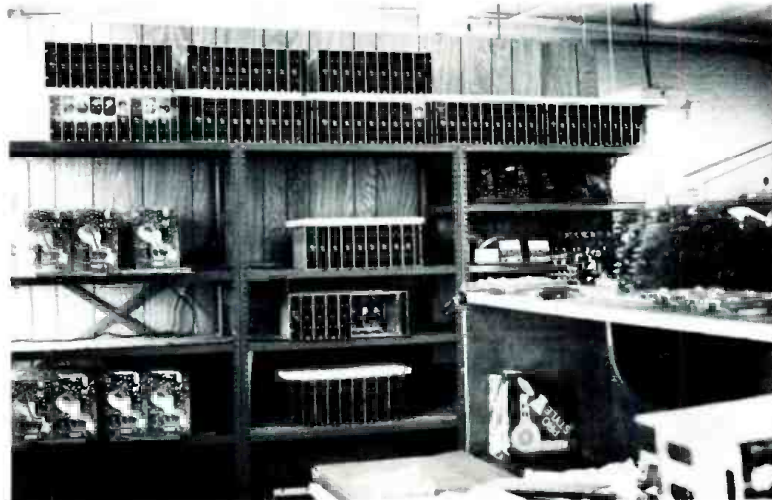

# Now available! The most important microphone book ever published.

Covers every significant aspect of theory and use from A to Z!

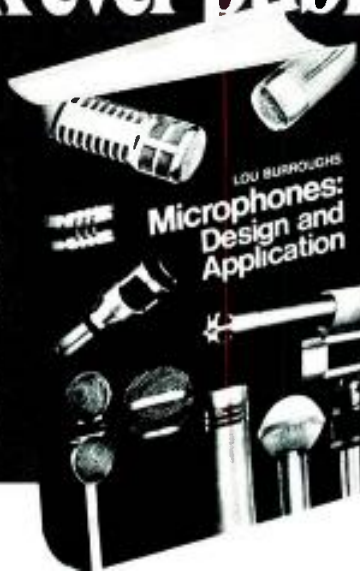

LOU BURROUGHS  
**Microphones:  
Design and  
Application**

**259 pages  
233  
illustrations**

LC #73-87056  
ISBN #0-914130-00-5

The whole field of microphone design and application has been prepared and explained in one concise, fact-filled volume by one of audio's outstanding experts. This book is complete, up-to-the-minute and so full of useful information, we think you'll use it every time you face a new or unusual microphone problem.

### Perfect for Reference or Trouble-Shooting

The twenty-six fact-packed chapters in this indispensable volume cover the whole field of microphones from theory, physical limitations, electro-acoustic limitations, maintenance and evaluation to applications, accessories and associated equipment. Each section is crammed with experience-tested, detailed information. And everything is arranged for easy reference because this is one handbook you'll turn to again and again. Whatever your audio specialty—you need this book!

Along with down-to-earth advice on trouble-free microphone applications, author Lou Burroughs passes on dozens of invaluable secrets learned through his many years of experience. He solves the practical problems you meet in day-to-day situations. For example:

- How does dirt in the microphone rob you of response?
- Which mic would you pick for a large auditorium?
- How are omni-directional mics used for orchestral pickup?
- When would you choose a cardioid, omni-directional or bi-directional mic?
- How do you space your microphones to bring out the best in each performer?

### Author

Lou Burroughs is widely known for his pioneering work with Electro-Voice and is one of the universally recognized experts in the field. He helped design and develop many of the microphones which made modern broadcasting possible. In fact, he holds 23 patents on electro-acoustical products! Lou Burroughs knows microphones inside out. This book is based on his many years of research, field studies and lectures given throughout the world.

This book is highly recommended as a teaching text and reference for all those in the audio industry.

---

## ORDER FORM

Sagamore Publishing Co. Inc. 980 Old Country Rd. Plainview, N.Y. 11803

Please send (     ) copies of MICROPHONES: DESIGN AND APPLICATION at \$20.00 each postpaid.

Name \_\_\_\_\_

Total amount \$ \_\_\_\_\_

Address \_\_\_\_\_

New York State Residents add 7% tax \$ \_\_\_\_\_

City \_\_\_\_\_ State \_\_\_\_\_ Zip \_\_\_\_\_

Enclosed is check for \$ \_\_\_\_\_  
Foreign orders add \$1 postg. & hndlg.

# CLASSIFIED

Closing date is the fifteenth of the second month preceding the date of issue. Send copy to: Classified Ad Dept.  
db THE SOUND ENGINEERING MAGAZINE  
980 Old Country Road, Plainview, New York 11803

Rates are 50¢ a word for commercial advertisements. Non-commercial and employment offered or wanted placements are accepted at 25¢ per word.

---

TUNED ROCK P.A.s customized touring sound systems, including narrow band (5 Hz!) feedback suppression, detailed Acousta-Voicing/environmental equalization ( $\pm 1$  dB at your ears), room design/measurement/treatment; 100's of customized professional products (J.B.L. & Altec Pro, Tascam, dbx, U.R.E.I., Eventide, Gately, Schöeps, Beyer, Crown, Community Light & Sound, Mom's Audio, McIntosh, etc. etc.) All shipped prepaid/insured from Music & Sound, Ltd., 11½ Old York Rd., Willow Grove, Pa. 19090. (215) 659-9251.  
Inventors—Engineers

---

DIRECT BOX, \$30.00. Four output headphone cue box with mute, channel select, mono/stereo, and pad switches, \$60.00. Gately Electronics, Inc., 57 West Hillcrest Avenue, Havertown, Pa. 19083. (215) 449-6400.

---

BROADCAST AND RECORDING EQUIPMENT: Scully; Metrotech; Langevine; Electrodyne; Q.R.K.; Micro-Trak; M.R.L.; Nortronics; McMartin; U.R.E.I.; used Neumann; E.V.; A.K.G.; Sennheiser; Atlas; Ferrograph; HAECO; Stevenson; Gately; D.B.X.; Advent; Altec; Fairchild; Audio Designs; 3 M; Magnacord; Telex; Inovonics; disc recording systems; package deals; installations; service. Wiegand Audio, Middleburg, Pennsylvania 17842. (717) 837-1444.

---

REEL SPECIALISTS; 10.5 inch reels, NAB \$2.00 each; Precision, \$5.00 each; other sizes available; NAB flanges, \$.75 each. Add 5 per cent postage. P.O. Box 338, Dunwoody, Ga. 30338.

---

---

## FOR SALE

---

SOLID-STATE AUDIO MODULES. Console kits, power amplifier kits, power supplies. Octal plug-ins—mic, eq, line, disc, tape play, tape record, amplifiers. Audio and tape bias oscillators. Over 50 audio products, send for free catalog and applications. Opamp Labs. Inc., 172 So. Alta Vista Blvd., Los Angeles, Ca. 90036. (213) 934-3566.

---

SPLICE FASTER, BETTER, BY SHEARING; replaces razor; attached splicing tape dispenser; quality workmanship; reasonably priced; endorsed by professionals. \$24.95 prepaid. Guaranteed. Distributors wanted. NRP, Box 289, McLean, Virginia 22101.

---

FAIRCHILD MODEL 641 STEREO DISC cutting system, \$2,500.00. Oak Recording Service, P.O. Box 336, Worth, Ill. 60482. (312) 425-4443.

---



**CATV—MATV PRODUCTS**

- CONNECTORS
- WALLPLATES
- SPLITTERS
- AMPLIFIERS



AVA ELECTRONICS CORP.  
242 Pembroke Avenue, Lansdowne, Pa. 19050  
(215) 284-2500

---

ONE WAY NOISE REDUCTION for cutting rooms/tape copies; retains highs, rids hiss/surface noise by a full 10 dB and costs \$300 per channel! Music & Sound, Ltd., 11½ Old York Rd., Willow Grove, Pa. 19090. (215) 659-9251.

---

NORTHWEST AREA, professional audio equipment and systems design. R. E. Munger Co., Seattle, Washington, (206) 365-1999. An Altec Acousta-Voice contractor.

---

AUSTRALIA'S TOP 16-TRACK STUDIO—Armstrong Studios, P.O. 296, Victoria 3205, has an immediate position for an experienced "rock/agency" mixer. Write: Allen Zentz, 6255 Sunset Blvd., #1905, Hollywood, Ca. 90028. (213) 462-3323.

---

AMPEX AG440-2 CONSOLE, late model, \$1,900; Ampex AG300-2 console, \$1,400; two Altec 605E speakers in Altec utility cabinet, \$150.00 each; Crown DC 300, \$400.00. Masterdisk Corp. (212) 541-5022.

---

UHER MODEL 4000 tape recorder; perfect, hardly used; microphone; leather case; extra briefcase speaker. Over \$750 new—sell \$300. M. Berger, 892 Hillgate, Pittsburgh, Pa. 15222. (412) 341-7983.

---

CUSTOM RECORD PRODUCTION (100 & up) from your tapes; also Scully-Westrex precision cut masters and acetate demos (stereo or mono). Request literature, Trutone Records, Dept. D, 6411 Bergenwood Ave., North Bergen, N.J. 07047. (201) 868-9332.

---



**ONE STOP  
FOR ALL YOUR PROFESSIONAL  
AUDIO REQUIREMENTS  
BOTTCM LINE ORIENTED  
F. T. C. BREWER CO.  
P.O. Box 8057, Pensacola, Fla. 32505**

WHATEVER YOUR EQUIPMENT NEEDS—new or used—check us first. We specialize in broadcast equipment. Write for our complete listings. **Broadcast Equipment & Supply Co., Box 3141, Bristol, Tenn. 37620.**

AMPEX 300, 352, 400, 450 USERS—for greater S/N ratio, replace first playback stage 12SJ7 with our plug-in transistor preamp. For specifications write **VIF International, Box 1555, Mountain View, Ca., 94042. (408) 739-9740.**

B.B.C. REFERENCE MONITORS; pre-equalized J.B.L./Altec/I.M.F. monitors; Eventide phasors/omnipressors/digital delays; McIntosh 16  $\Omega$  power amps; dbx compressors; Little Dipper hum/buzz notch filters; Cooper Time Cube echo delay; Ortofon and B. & O. ultra-track cartridges; Schöeps & A.K.G. condensers; Beyer ribbons; U.R.E.I. comp/limiters; Gately Pro-Kits; Infinity electrostatics; Crown amplifiers/recorders; Tascam, Community Light & Sound fiberglass horns; Q.R.K.; 100's more, plus class "A" warranty service station. **Music & Sound, Ltd., 11½ Old York Rd., Willow Grove, Pa., 19090. (215) 659-9251.**

**All Shipped Prepaid/Insured**

AMPEX, SCULLY, TASCAM; all major professional audio lines. Service, experience, integrity. 15 minutes **George Washington Bridge. Professional Audio Video Corporation, 342 Main St., Paterson, N.J. 07505. (201) 523-3333.**

NEW 3M M-79 FOUR-TRACK, \$5,500. **Charles M. Solak, (215) 363-7855, (607) 797-3909.**

FOR SALE: MCI JH-416 CONSOLES, 24 x 24, \$19,000; 16 x 16, \$13,500; JH-16 16-track w/auto locator, \$13,000, two months old. **Sound 80, 2709 E. 25th St., Minneapolis, Minn. 55406. (612) 721-6341.**

FOR SALE: QUAD EIGHT 16-in/8-out console; three years old; complete 16-track monitoring; full patch bay and producer's desk. \$14,500. **Creative Workshop, 2804 Azalea Pl., Nashville, Tenn. 37204. (615) 385-0670 or 383-8682.**

HP205AG—\$200; HP330B—\$275; HP650A—\$195; several Textronix 530 series oscilloscopes; other instruments. **Design Consultants, Box 67, Richardson, Texas 75080.**

TASCAM REVERBS; Tascam Mixing Consoles—\$1,890; Tascam ½ inch recorders—\$1,950; Tascam 8-track recorders—\$3,970. All shipped prepaid/insured, including free alignment/equalization/bias/calibration. **Music & Sound, Ltd., 11½ Old York Rd., Willow Grove, Pa. 19090. (215) 659-9251.**

FOR SALE: 18-IN x 4-OUT NEUMANN self-contained console; Dannier faders, multi-range EQ, three-position low-cut filter, cue and echo before/after on each input; five-position oscillator; talk back; four channel and mono monitoring; excellent condition; original cost \$35,000, asking \$10,000. **Pams, Inc., Bruce Collier, 4141 Office Pkwy., Dallas, Texas 75204. (214) 827-0901.**

ORTOFON DYNAMIC MOTIONAL FEEDBACK mono disc cutting system. Complete amplifier system: drive, feedback, and feedback-playback monitor preamp; rebuilt, original factory parts. Guaranteed. **Albert B. Grundy, 64 University Place, New York, N.Y. 10003. (212) 929-8364.**

FOR SALE: QUAD 8 16-TRACK CONSOLE; 20 input/16 output. Price \$12,500. **Martin Lennard, (212) 596-8823 or (212) 725-5323.**

NEW YORK'S LEADING PRO AUDIO/VIDEO DISTRIBUTOR for audio, video, broadcast, public address, and hi-fi systems; representing over 130 audio/video manufacturers, featuring such names as Ampex, Scully, Tascam, Sony, J. B. Lansing, Neumann, Altec, McIntosh, AKG, Dynair, T.V. Microtime, UREI, 3M, and other major brands; the largest "in stock" inventory of equipment, accessories, and parts; competitive discount prices; factory authorized sales, service, parts, systems design, installation. Write for free catalog! **Martin Audio/Video Corporation, 320 W. 46th St., New York, N.Y. 10036. (212) 541-5900.**

HAECO announces complete repair service and overhaul for all Westrex cutterheads. Conversions of 3D-II and older models to higher performance standards and reliability. Helium cooling systems and hi-temp coils can protect your investment. Repair insurance program available. Rapid service. Lower cost. **HAECO, 14110 Aetna, Van Nuys, California 91401.**

## MULTI-TRACK

8 and 16

TRACK RECORDING CONSOLES  
THE SOUNDEST DOLLAR SPENT  
IN PRO AUDIO TODAY

1965 CHEREMOYA AVE.,  
HOLLYWOOD, CALIF. 90028  
P.O. Box 3187, Hollywood, CA. 90028  
(213) 467-7890

NEW YORK'S ORIGINAL ELECTRONIC WORKSHOP now has New York City's finest audio showroom, featuring Infinity, ESS, Phase Linear, Bose, Crown, Bang & Olufsen, etc.; knowledgeable and helpful sales assistance that is hard to find. We invite you to pay us an early visit. **Electronic Workshop, 10 E 8th St., New York, N.Y. 10003. (212) GR 3-0140.**

FREE ROOM EQUALIZATION with purchase of ⅓-octave filter sets. This is not a misprint. **Music & Sound, Ltd., 11½ Old York Rd., Willow Grove, Pa. 19090. (215) 659-9251.**

WE INSTALL STUDIOS from two-track up into sixteen- or even forty-track, from control consoles to tape recorders. Let us know what you want and we'll be happy to lay out plans for your individual needs. Contact **Monex Corporation of Iowa, P.O. Box 3225, Des Moines, Iowa 50316.**

LOWEST PRICES, fastest delivery on Scotch recording tapes, all widths. We will not be undersold. **Amboy Audio Associates, 236 Walnut Street, South Amboy, N.J. 08879. (201) 721-5121.**

AUDIO EQUIPMENT, new and used; custom consoles built to your specifications using the components of your choice. Whether you're building a new studio or remodeling your present one, check us first for a package price. **Amboy Audio Associates, 236 Walnut St., South Amboy, N.J. 08879. (201) 721-5121.**

TWO 8DG LATHES with cutting head and amplifiers; 45 and 33⅓. \$900.00 each. **Telephone (615) 227-5027.**

### WANTED

WANTED: AMPEX 622 speaker/amp, or 2101s. **Dalzell, 927 Runnymede Lane, San Diego, Ca. 92106.**

### EMPLOYMENT

CONSCIENTIOUS TECHNICIAN to take over tape-duplicating and a/v services to educational publishers. Midtown NYC apartment included. (212) CI 5-3056.

PROFESSIONAL RECORDING PERSONNEL SPECIALISTS. A service for employers and job seekers. Call today! **Smith's Personnel Service, 1457 Broadway, N.Y.C. 10036. Alayne Spertell 212 WI 7-3806.**

# PEOPLE, PLACES, HAPPENINGS

● Youth is the word for a new recording center recently opened in Indianapolis at 1330 N. Illinois by the **Talun Record Corporation**, whose executives are all under thirty. The center contains the firm's new Music Mother sixteen-track studios as well as offices and creative facilities for its two record labels, music publisher, and audio production firm. The Music Mother offers quadraphonic mixing and a full line of M 79 3M tape machines. The studio contains a twenty four-track Audiotronics board, twenty channels of Dolby A (including the M 16) four AKG echo chambers, four M 79 tape machines, and quadraphonic Sentry III monitors. In addition for providing facilities for young music, according to **Tom F. Hirschauer, Jr.**, Talun vice president, the firm is conscious of its responsibility toward young students and has offered free use of its facilities for tours and seminars to local schools. They also hope to get into educational recording.



● Flexible service is promised by **Minot Sound Studios**, headed by **Ron Carran**, recently opened in White Plains, N.Y. Minot offers on-location recording, sound system installation, and the use of a music and special effects library. Recording equipment available includes MCI recording console, AKG reverberation chambers and a Dolby noise reduction system, all under the supervision of professional musicians.



● Prestigious **EMI Group** studios located throughout the world will be supplied with custom-built consoles from **Rupert Neve, Inc.** as the result of a half-million dollar order recently received. The 16-track and 24-track consoles will be installed at EMI studios in London (the well-known Abbey Road), Cologne, Singapore, Wellington, N.Z., Paris, and Stockholm.



**Carter**

● Portland, Oregon will be served by a new commercial sound recording studio, **Spectrum Studios, Inc.**, located at 905 SW Alder. Partners in the venture include **Mike Carter**, **Lindsey McGill**, and **Lee McCormick**, all of whom come from **Northwestern, Inc.** Facilities will include three sound studios, for recording and duplicating audio for radio and television commercials, music mastering, film sound, audio-visual programs, and multimedia productions.

● A new company, specializing in European products has been formed by the **Hervic Corporation/Cinema Beaulieu**. Called **Hervic Electronics, Inc.** the new branch will be headed by **George A. Rose** in the post of executive vice president for marketing and sales. According to Mr. Rose, the company will offer highly sophisticated systems and components from England, France, Germany, and Switzerland. The initial line will be the **Diton Series** loudspeakers manufactured in England by **Rolla Celestion, Ltd.** which will be sold on a franchise basis. Other projected lines will include microphones, recorders, including sync recorders for movie cameras, changers, amplifiers, integrated stereo components, amplifiers, integrated stereo receivers and headphones. Main offices for the new company are located at 1508 Cotner Avenue, Los Angeles, California 90025.

● **John A. Mattis**, known for his part in the development of linear integrated circuits and the monolithic phase-locked loop while an electronic design engineer with the **Signetics Corporation**, has been named manager of the linear-products marketing group of Signetics. The position will encompass the guiding of the development of this new form of circuitry and its marketing for such uses as automobile speed control systems and in four-channel stereophonic systems. In addition to creative designing work, Mr. Mattis has published a number of technical articles in the electronic trade press.



## The Model 10 Mixing Console

### When you've got more talent than money

Any mixing console is simply a creative tool. Getting the most out of it calls for imaginative insight into music and skill in the practical application of sound.

If you've got the talent but you don't have the money,

you're exactly who we built this board for.

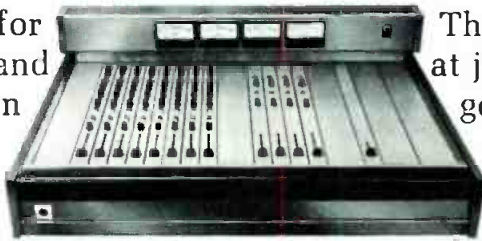

The basic 8-in, 4-out board starts at just \$1890. From there you can go to 24-in, with options and accessories enough to fill a studio.

The TASCAM Model 10. It gets your inside outside.

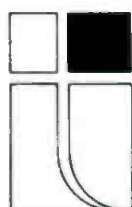

**TASCAM CORPORATION**

5440 McConnell Avenue  
Los Angeles, Calif. 90066

Circle 11 on Reader Service Card

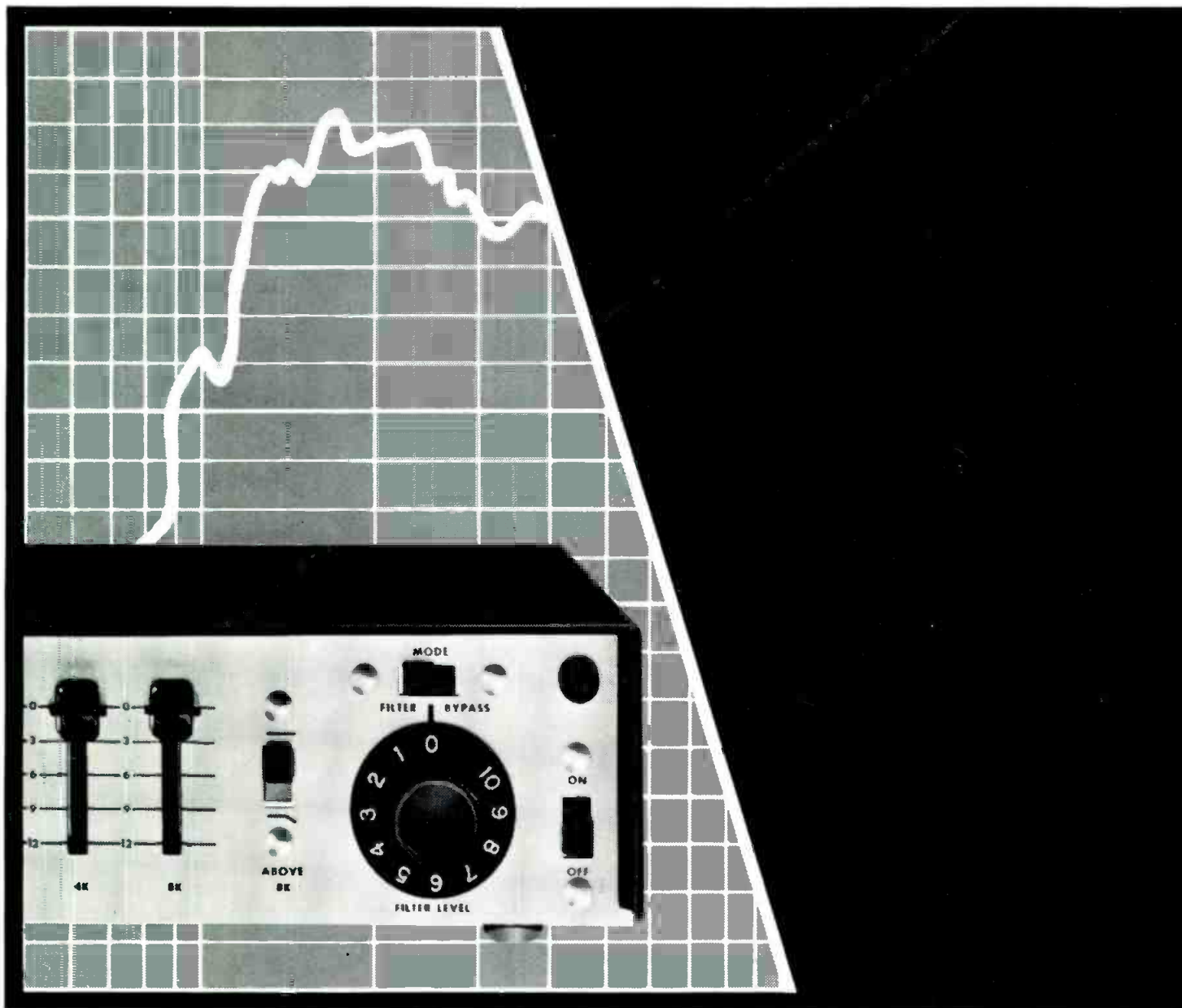

## The feedback buck stops here.

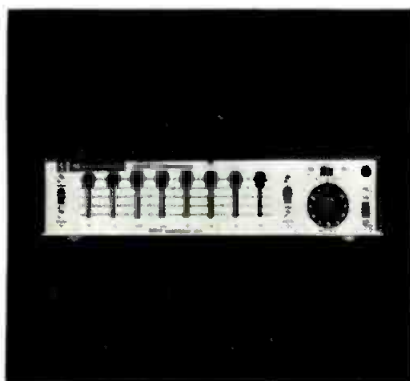

They said it couldn't be done, but our engineers developed a simple, low-cost component to give sound reinforcement systems *increased gain with reduced feedback danger!* The Shure M610 Feedback Controller utilizes eight resonant dip filters and high- and low-end roll-off switches which enable the user to "tune" system response to room acoustics, maximizing output and minimizing feedback. Convenient filter level control allows increase of system gain as filters are adjusted. Use the M610 to control feedback in any acoustic environment; use it to filter problem frequencies that cause ringing, boominess or other troublesome resonances. Yours for \$117.00, user net. Write:

Shure Brothers Inc.  
222 Hartrey Ave., Evanston, Ill. 60204  
In Canada: A. C. Simmonds & Sons, Ltd.



Circle 12 on Reader Service Card