

50186 AM SEATTLE  
329 COMMUNICATIONS BLDG  
6



The new advanced-design MQ-Series mixers.

# RIGHT ON THE MONEY.

Introducing the MQ-Series. A new line of highly affordable mixers that refuse to compromise with audio performance. Or with your needs.

You get the tonal flexibility of a 4-band EQ on each channel and the added flexibility of per-channel echo and foldback

sends. Plus a pair of master-program 9-band graphic equalizers. And direct interface flexibility with per-channel dual input switching.

There's also the dependability and service convenience of a modular layout with each channel's components mounted on a separate internal printed

circuit board. The MQ-Series. Right on the money, right down the line.

Visit your Yamaha dealer or write us for more information. Yamaha, Box 6600, Buena Park, CA 90622. In Canada, Yamaha Canada Music Ltd., 135 Milner Ave., Scarb., Ont. M1S 3R1.

Combo Products

THE WAY IT WILL BE.

 **YAMAHA**

Circle 10 on Reader Service Card



Publisher  
**Larry Zide**

Editor  
**John M. Woram**

European Editor  
**John Borwick**

Associate Editor  
**Mark B. Waldstein**

Production & Layout  
**David Kramer**

Advertising Coordinator  
**Karen Cohn**

Classified Advertising  
**Carol Vitelli**

Book Sales  
**Lydia Calogrides**

Circulation Manager  
**Eloise Beach**

Art Director  
**Bob Laurie**

Graphics  
**K & S Graphics**

Typography  
**Spartan Phototype Co.**

sales offices

**Roy McDonald Associates, Inc.**  
Dallas, Texas 75207

First Continental Bank Bldg.  
801 Marvin D. Love Freeway  
Suite 303  
(214) 941-4461

Denver, Colorado Area

**Englewood, Colorado 80112**  
14 Inverness Dr. East  
Bldg. 1—Penthouse  
(303) 771-8181

Houston, Texas 77036

6901 Corporate Drive  
Suite 210  
(713) 988-5005

Los Angeles Area

**Glendale, California 91204**  
424 West Colorado Street  
Suite 201  
(213) 244-8176

Portland Area

**Hillsboro, Oregon 97123**  
510 South First  
P.O. Box 696  
(503) 640-2011

San Francisco Area

**Emeryville, California 94608**  
265 Baybridge Office Plaza  
5801 Christie Avenue  
(415) 653-2122

Sagamore Publishing Co.

New York  
**Plainview, NY 11803**  
1120 Old Country Rd.  
(516) 433-6530



SEPTEMBER 1982 VOLUME 16, NO. 9

## DEPARTMENTS

| LETTERS                    | EDITORIAL | CLASSIFIED    |
|----------------------------|-----------|---------------|
| 6                          | 32        | 60            |
| <hr/>                      |           |               |
| DIGITAL AUDIO              |           | Barry Blesser |
| 12                         |           |               |
| <hr/>                      |           |               |
| THEORY AND PRACTICE        |           | Ken Pohlmann  |
| 18                         |           |               |
| <hr/>                      |           |               |
| SOUND WITH IMAGES          |           | Len Feldman   |
| 24                         |           |               |
| <hr/>                      |           |               |
| SOUND REINFORCEMENT        |           | John Eargle   |
| 30                         |           |               |
| <hr/>                      |           |               |
| NEW PRODUCTS AND SERVICES  |           |               |
| 58                         |           |               |
| <hr/>                      |           |               |
| PEOPLE, PLACES, HAPPENINGS |           |               |
| 62                         |           |               |

## FEATURES

|  |   |
|--|---|
| THE SOUNDSTREAM DIGITAL MUSIC<br>COMPUTER: RECORDING, EDITING AND BEYOND                         | Sherman Keene                             |
| 34   |   |
| <hr/>  |   |
| THE MAN BEHIND SOUNDSTREAM   |   |
| 39   |   |
| <hr/>  |   |
| TO BUILD THE IMPOSSIBLE DREAM:<br>A SOUND-INSULATED PERFORMANCE<br>STUDIO COMES TO THE BIG APPLE | Richard Koziol and<br>Alfred W. D'Alessio |
| 44   |   |
| <hr/>  |   |
| A db APPLICATION NOTE:<br>TECHNIQUES FOR HUM AND NOISE REDUCTION                                 | Dale Beard                                |
| 47   |   |
| <hr/>  |   |
| THE FFT: BIG-TIME MATHEMATICS<br>COMES TO AUDIO  | Robert Berkovitz                          |
| 52   |   |
| <hr/>  |   |
| NEW YORK'S CENTER FOR THE MEDIA ARTS<br>ADDS A SCHOOL OF AUDIO ARTS                              | Joseph Coencas                            |
| 57   |   |

## About The Cover

• This month's cover, courtesy of Gregg Stephens, features some of the equipment currently employed in Soundstream's Digital Editing Facility in Hollywood, California.

db, the Sound Engineering Magazine (ISSN 0011-7145) is published monthly by Sagamore Publishing Company, Inc. Entire contents copyright © 1982 by Sagamore Publishing Co., 1120 Old Country Road, Plainview, L.I., N.Y. 11803. Telephone (516) 433-6530. db is published for those individuals and firms in professional audio-recording, broadcast, audio-visual, sound reinforcement, consultants, video recording, film sound, etc. Application should be made on the subscription form in the rear of each issue. Subscriptions are \$15.00 per year (\$28.00 per year outside U.S. Possessions; \$16.00 per year Canada) in U.S. funds. Single copies are \$1.95 each. Editorial, Publishing and Sales Offices: 1120 Old Country Road, Plainview, New York 11803. Controlled circulation postage paid at Plainview, NY 11803 and an additional mailing office.

# Audio Tape for professionals



## REEL TO REEL TAPE

Ampex, 3M. All grades.  
On reels or hubs.

## CASSETTES, C-10—C-90

With Agfa, TDK tape.

## LEADER & SPLICING TAPE

## EMPTY REELS & BOXES

All widths, sizes.

**Competitive!  
Shipped from Stock!**

Ask for our recording supplies catalog.

**Poly Inc.**  
Corp. 312/298-5300

1233 Rand Rd. • Des Plaines, IL 60016

15

Circle 20 on Reader Service Card

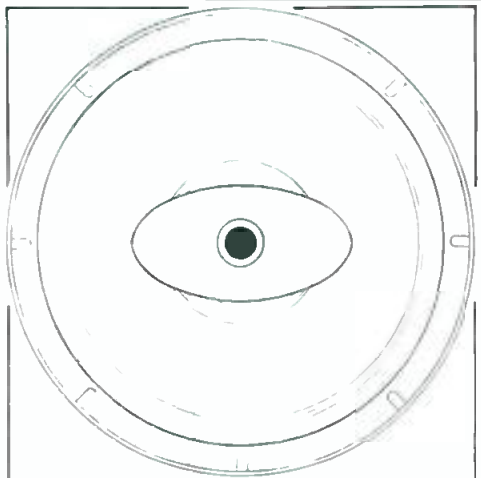

## EHL-15 CO-AX

200 Watts

103 dB M/W

Double Spider

15 Inch

# EMILAR

For complete information call  
714-632-8500 — 800-854-7181

**EMILAR CORPORATION**

1365 N. McCan St.  
Anaheim, CA 92806

Circle 15 on Reader Service Card

# db Letters

## db OR NOT dB

TO THE EDITOR:

After an exasperating hour at a local library, doing research for the Audio-Technica style book, I am turning to you for your thoughts on a matter which must be of some importance to you, since it involves the word from which your publication derives its name: the decibel.

I am looking for an "unimpeachable" authority on whether a db is really a dB. (Your own publication seems to be sitting squarely on the fence, since you spell your name *db* on the masthead, but you frequently use *dB* in textual matter.) The standard reference of writers and editors, *A Manual of Style*, by the University of Chicago Press, lower-cases both the word and its abbreviations: *decibel*, *db*. So does *Webster's New Collegiate Dictionary* and the *Oxford Dictionary of American English*. Most of the manufacturers and publishers in our industry, however, still use *dB*.

Perhaps we should emulate the diner who, knowing he is incorrect in doing so, orders "turbo" for "turbot," instead of the approved *turbat*, for fear those around him will think him uneducated. Apparently, *dB* is wrong, but many of our customers and colleagues would undoubtedly think us illiterate if we spelled it *db*.

One stylistic area in which we enthusiastically agree with Webster's is that the proper abbreviation for microphone is *mike*, rather than *mic*. Since the abbreviation is pronounced as a word, the rules of pronunciation would mandate calling it "mick"—as in *pic*, *hic*, or *tic*. Another good reason for *mike* is that it avoids the god-awful term "micing," when used as a verb, in the participial form.

Please let me have the benefit of any research you or your fellow editors may have done on these terms. I'll hold up on our style book until I hear from you and some of the lexicographers and style book editors to whom I'll pose the same questions.

DON KIRKENDALL  
Director  
Marketing Communications  
Audio-Technica U.S., Inc.

## db (dB?) replies:

*db (the Magazine) got started in 1967, when life was a lot simpler, and the decibel had a long history of being abbreviated as "db." However, in current engineering practice, units of measure which use a person's name are spelled out in small letters, but abbreviated with a capital letter, with no period (unless at*

# Index of Advertisers

|                           |          |
|---------------------------|----------|
| Alpha Audio .....         | 25       |
| Ampex .....               | Cover II |
| Audio-Technica .....      | 23       |
| Beyer .....               | 20       |
| Bose .....                | 21       |
| Cetec Vega .....          | 11       |
| CTAB .....                | 22       |
| Datatronics .....         | 16       |
| Emilar .....              | 6        |
| Harvey Professional ..... | 19       |
| Hewlett-Packard .....     | 7        |
| JBL .....                 | 9        |
| Kimball .....             | 8        |
| Klark Teknik .....        | 10, 43   |
| Maxell .....              | 15       |
| Orban .....               | 12       |
| Otari .....               | Cover IV |
| Peavey .....              | 28-29    |
| Polyline .....            | 6        |
| Pro Audio Yearbook .....  | 27       |
| Shure .....               | 14       |
| Studer .....              | 33       |
| Swintek .....             | 18       |
| Telex .....               | 45       |
| Tentel .....              | 10       |
| TOA .....                 | 34-35    |
| Trident .....             | 8        |

# Coming Next Month

• Next month is our AES show issue, and we'll be featuring articles on a wide range of topics. Ham Brosious of Audio-techniques checks in with a feature outlining the pros and cons of renting pro audio gear; Richard Factor of Eventide brings us a progress report on the micro-processor; Murray Allen of Universal Studios gives us some insights on what can go wrong on *both* sides of the control room window, and our own John Woram shows how a programmable calculator can be used to design a sophisticated sound system. Of course, our regular departments and columnists will be on hand, making October's **db—The Sound Engineering Magazine**, a show issue to remember.



# Now hear this!



## HP's 8903A now makes audio testing easier than ever before.

Now a single microprocessor-controlled instrument offers you the versatility of an extremely wide range of audio measurements with just a few keystrokes. Manual or HP-IB programmable, the HP 8903A Audio Analyzer is ideal for testing 20 Hz to 100 kHz characteristics of stereo amplifiers, pre- and line amplifiers, tape decks, cassettes, and other high performance audio equipment.

The 8903A measures such basics as distortion, gain and frequency response,

power, AC or DC volts, and frequency; as well as more complex parameters like signal-to-noise and SINAD. It includes a sweepable low distortion audio source and drives an X-Y recorder directly. It's an automatic test system all in one box, yet is priced at only \$6600\*.

For more information, contact your nearby HP sales office, or write to Hewlett-Packard Co., 1820 Embarcadero Road, Palo Alto, CA 94303.

\*Domestic US price only.

04105A



**HEWLETT  
PACKARD**



Circle 18 on Reader Service Card

# TRIDENT QUALITY YOU CAN AFFORD

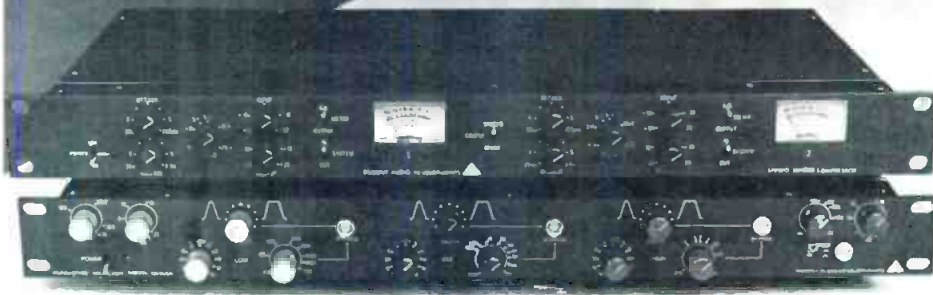

**Limiter/  
Compressor  
LC-1**  
\$695.00

- Two independent channels
- Continuously variable slope
- Stereo coupling
- Illuminated V.U. meters for gain reduction or output level
- High performance at low cost
- Compact size (19" x 1 3/4" x 8")

**Parametric  
Equalizer  
CB9066**  
\$650.00

- 3 band eq.
- Variable "Q"
- Separate Bypass for each band
- Hi & Low Pass Filters with continuously variable frequency and slope
- Built-in power supply
- Compact size (19" x 1 3/4" x 8")



TRIDENT (USA)

Order direct:  
652 Glenbrook Rd., Stamford, CT 06906 (203) 357-8337

Circle 19 on Reader Service Card

## More and more recording studios are discovering the great sound of the Kimball Professional Grand.

### Here's why:

The Kimball 6'7" Professional Grand derives its heritage of greatness from the world's finest piano—the Bosendorfer. The scale and plate design are derived from the Bosendorfer Model 200, and the plate is extra thick to assure maximum sustain and to avoid plate noise from hammer strikes. The Bosendorfer-derived scale and non-duplexed trebles enhance tonal depth, clarity, and pitch perception. The Kimball Professional Grand is specifically designed for clear, pure tonality, free of spurious noise and false harmonics. It also offers superior durability and tuning stability. Its entire structure, including the soundboard, is of precision-laminated woods, greatly reducing differential expansion in changes of temperature and humidity.



For more information about the Kimball Professional Grand, contact Wade Bray at (812) 482-1600.



**Kimball**

"The key to sounding great!"  
1549 Royal St. Box 460  
Jasper, IN 47546

Circle 14 on Reader Service Card

the end of a sentence, of course). Thus, we have 9 V (not 9V) = 9 volts.

Multiplier prefixes are capitalized only above 10<sup>6</sup> (= M). This gives us 1,500,000 volts = 1.5 MV, while 0.001 volt (not volts) = 1 mV. Moving right along toward the big finale, 1 bel = 1 B = 10 decibels = 10 dB. Most audio publications made the move lower case, and will probably end it that way (hopefully, not soon).

As for that transducer you mentioned, we usually cop out by completely spelling it out. Mike technique suggests something that Michael does very well, and micing is probably best left to an exterminator, or the studio cat.

Now then, can anyone tell us how to pronounce EQ?

### SPEAKING OF MICE...

#### TO THE EDITOR:

Congratulations on a fine June issue.

Just two minor items: I've checked every condenser microphone here at Sony and a few by other manufacturers and I can't find one *black* electret. Most of ours are gold. I'd telex Japan to ask them, but I don't think they'd see the humor in it.

And to answer your question in the AES News section of "Happenings," yes, Sony will be there. It should be a good show, even if the place has mice.

JOHN F. PHELAN  
Western Regional Sales Mgr.  
Sony Corp. of America

#### db replies:

Don't send that telex—there's nothing funny about black electrets, although they might help our micing technique. Sorry about the typo. We'd fire the proof-reader, if we had one.





# Before you invest in new studio monitors, consider all the angles.

No one has to tell you how important flat frequency response is in a studio monitor. But if you judge a monitor's performance by its on-axis response curve, you're only getting part of the story.

Most conventional monitors tend to narrow their dispersion as frequency increases. So while their on-axis response may be flat, their off-axis response can roll off dramatically, literally locking you into the on-axis "sweet spot." Even worse, drastic changes in the horn's directivity contribute significantly to horn colorations.

## Introducing the JBL Bi-Radial Studio Monitors.

At JBL, we've been investigating the relationship between on and off axis frequency response for several years. The result is a new generation of studio monitors that provide flat response over an exceptionally wide range of horizontal and vertical angles. The sweet spot and its traditional restrictions are essentially eliminated.

The key to this improved performance lies in the unique geometry of the monitors' Bi-Radial horn. Developed with the aid of the latest computer design and analysis techniques, the horn provides constant coverage from its crossover point of 1000 Hz to beyond 16 kHz. The Bi-Radial compound flare configuration maintains precise control of the horn's wide  $100^\circ \times 100^\circ$  coverage angle.

U. Patent applied for.

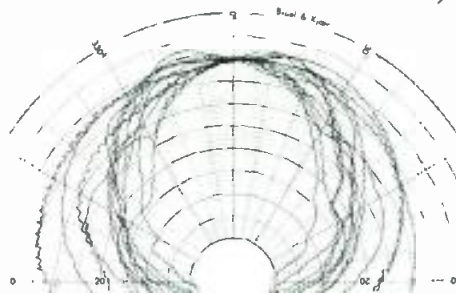

Typical horizontal

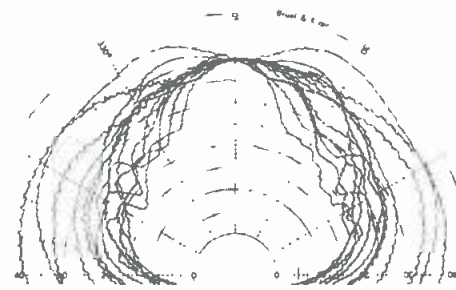

Typical vertical

*Polar response comparison of a typical two-way coaxial studio monitor and JBL's new 4430 Bi-Radial studio monitor from 1 kHz to 16 kHz.*

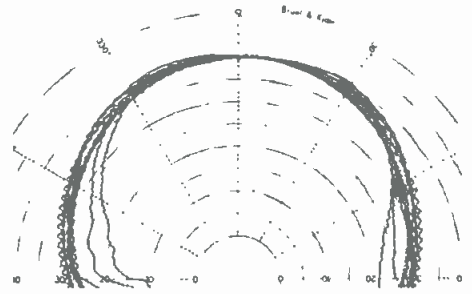

JBL 4430 horizontal

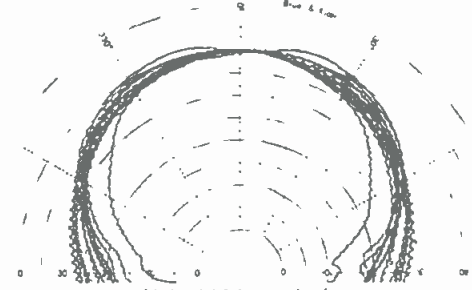

JBL 4430 vertical

And the Bi-Radial horn's performance advantages aren't limited to just beamwidth control. The horn's rapid flare rate, for instance, dramatically reduces second harmonic distortion and its shallow depth allows for optimal acoustic alignment of the drivers. This alignment lets the monitors fall well below the Blauert and Laws criteria for minimum audible time delay discrepancies.

But while the Bi-Radial horn offers outstanding performance, it's only part of the total package. The new monitors also incorporate JBL's most advanced high and low frequency transducers and dividing networks. Working together, these

components provide exceptionally smooth response, high power capacity, extended bandwidth, and extremely low distortion.

## Judge For Yourself

Of course, the only way to really judge a studio monitor is to listen for yourself. So before you invest in new monitors, ask your local JBL professional products dealer for a Bi-Radial monitor demonstration. And consider all the angles.

James B. Lansing Sound, Inc.  
8500 Balboa Boulevard  
P.O. Box 2200  
Northridge, California 91329 U.S.A.

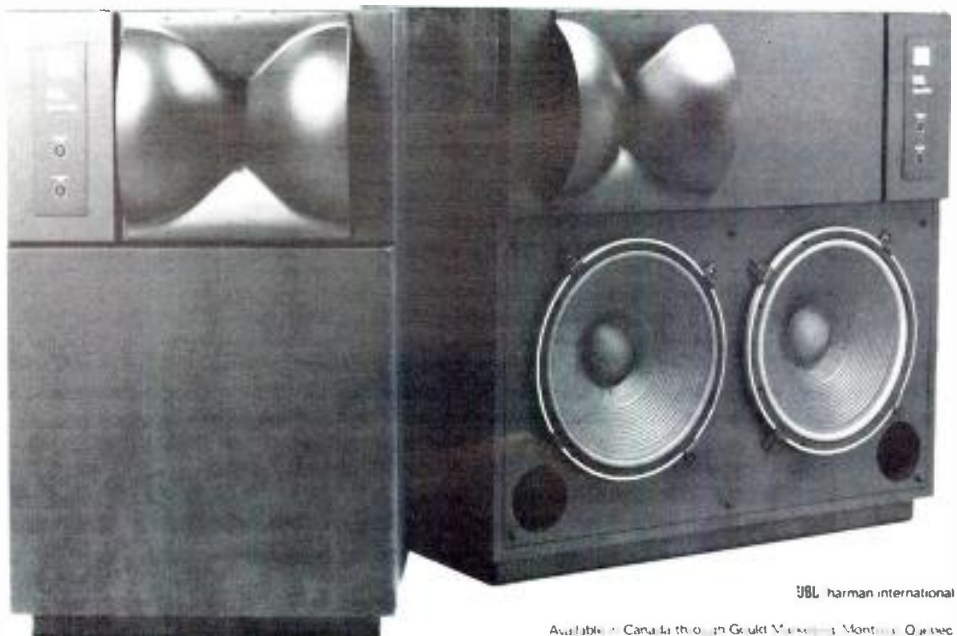

**JBL** Professional Products Division

JBL harman international

Available in Canada through Gold Medal Music Montreal Quebec

Circle 17 on Reader Service Card

**CLOSING THE CREDIBILITY GAP**

TO THE EDITOR:

In my letter of May 29, I called to your attention some misinformation published in the May "Sound with Images" column. This was never acknowledged, nor were my questions answered. I would like to see a statement by the editor or the author in reference to the points raised. I feel that corrections should be published for the edification of your readers. Your credibility shall suffer severely otherwise.

**BN SOBIN**  
Ben Sobin Motion Picture  
Sound Recording and Equipment

**db replies:**

*Go easy on us, Ben. Your letter and our editor's/author's replies were published in the July issue. Unfortunately, by the time our subscribers receive db, the next issue is already at the printer, and the next one after that is well on the way there. We try to hold the letters column open until the very last moment (this one just sneaked in under the wire), but there's inevitably a  $\Delta t$  of a month or two, especially if your letter requires an author's response.*

**ACCURATE  
TAPE TENSION  
MAKES BETTER  
RECORDINGS**

*If something SOUNDS FISHY it may be your fish scale approach to measuring tension.*



The Tentele Tape Tension Gage is designed to diagnose problems in your magnetic tape equipment. Virtually all recorder manufacturers use and recommend the TENTELOMETER® for use with their equipment.

The TENTELOMETER® measures tape tension while your transport is in operation, so you can "see" how your transport is handling your tape. High tension causing premature head and tape wear, low tension causing loss of high frequencies, or oscillations causing wow and flutter. Send for the Tentele "Tape Tips Guide". The T2-H20-ML sells for \$279 - complete.

**TENTEL**  
1506 Dell Avenue  
Campbell, CA 95008  
(408) 379-1881  
Toll Free 800 538-6894 (ex. CA)

Circle 12 on Reader Service Card

# Brooke Siren Systems

For years our MCS200 series crossovers have been used by major touring companies worldwide. The same high technology is available in our FDS300 series crossovers. Our products include some very unique features, highlighted below, but perhaps our best feature is the way we'll sound with you. Available now through professional audio distributors and music stores nationwide.

- 24dB/Octave Slope
- Subsonic/Ultrasonic Filters
- Section Mute Control
- Limiters on Each Section
- ±6dB Level Control
- Sealed Potentiometers



**Brooke Siren Systems, 262A Eastern Parkway, Farmingdale, New York 11735 (516) 249-3660**  
**Gerraudio Inc., 363 Adelaide Street East, Toronto, Ontario M5A 1N3 (416) 361-1667**



## Frequency Dividing Systems

- FDS320 2-Way Stereo
- AR116 Active Direct Box
- MCS200 Modular Series 3, 4, or 5-Way Stereo
- FDS340 3 or 4-Way Mono
- AR125 Cable Tester

Circle 13 on Reader Service Card



# Brilliant performer.

**NEW  
WIRELESS**

## Model 82 Wireless Condenser Hand-Held

The Model 82 condenser wireless microphone has been added to Cetec Vega's professional hand-held line. The Model 82 incorporates the popular Shure SM85 condenser element and attractive black windscreen to provide:

- Minimal handling noise, reduced mechanical vibration, and virtually no "boominess" (by means of controlled low-frequency rolloff).
- Clean reproduction of close-up vocals with moderate proximity effect.
- "Crispness" and presence with high-definition midrange.
- Clear, scintillating highs with crisp upper register.
- Cardioid pickup pattern for effective rejection of off-axis sounds.

All Cetec Vega hand-held wireless microphones (including the Model 80 with the Electro-Voice EV-671 dynamic element and the Model 81

with the Shure SM58 dynamic element) have an attractively contoured black case with internal antenna.

Used with Cetec Vega professional wireless receivers, the FM systems operate on any crystal-controlled frequency between 150 to 216 MHz, at a range up to 1000 feet or more. Transmit-to-receive frequency response is almost perfectly flat from 100 Hz to 12 kHz with gentle rolloffs to 40 Hz and 15 kHz. Total harmonic distortion is typically 1/2 percent. System dynamic range is 90 dB when "Dynex" (transmit compression and receive expansion) is incorporated, with a resulting low noise floor.

Cetec Vega hand-held wireless microphones are newly redesigned for 20 to 30 percent additional battery life, using a commonly available 9-volt alkaline battery (Duracell recommended). Microphone sensitivity is easily adjustable with an audio

gain control on the bottom, with an adjacent LED indicator to verify optimum setup. Power and audio on/off switches are also conveniently located on the bottom.

Write or call for further information and location of your nearest dealer: Cetec Vega, P.O. Box 5348, El Monte, CA 91731. (213) 442-0782  
TWX: 910-587-3539

*In Canada: A.C. Simmonds & Sons Ltd.*

**Cetec Vega**

Division of Cetec Corporation



Circle 16 on Reader Service Card

## Digital Filter Design: Part I

• The design of digital filters has generally been left to mathematically-oriented engineers, since a high level of technical expertise is necessary to build such systems. This contrasts with analog filter design, where readily available tables of circuits and values can be used to construct filters. As time marches on, digital filters will also become the province of practical engineers without the mathematics. In the next series of articles we will try to develop some of the ideas necessary to digital filter design.

Before beginning, I would like to note that the mathematics actually makes the design task much simpler rather than much harder. Therefore, I'll try to introduce mathematics (gently!) when necessary.

### LINEARITY

All filters, whether digital or analog, are based on linearity, which is a mathematical abstraction. It simply means that if I place a time signal  $x(t)$  into a system

and  $y(t)$  comes out, then if I place  $2x(t)$  into the system,  $2y(t)$  will come out; doubling the input doubles the output. Similarly, multiplying the input by any constant will result in multiplying the output by the same constant.

A further extension of linearity says that if  $x_1(t)$  produces  $y_1(t)$  and  $x_2(t)$  produces  $y_2(t)$ ,  $x_2(t)$  will produce  $y_1(t) + y_2(t)$ . Most audio systems approach this mathematical notion of linearity. Increasing the input signal increases the output signal. Adding a trumpet and a violin at

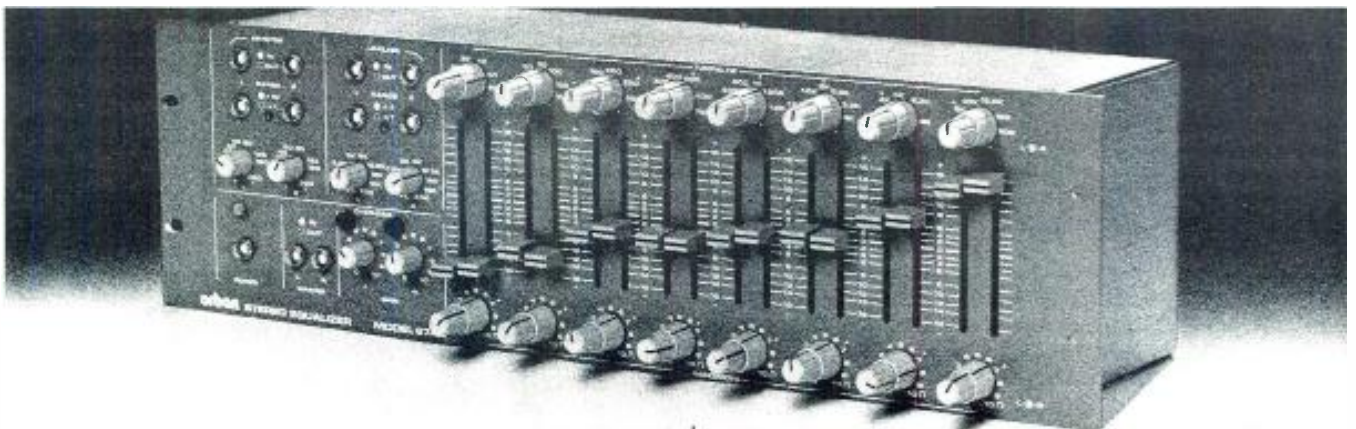

## The Dream Equalizer: Now mono or stereo.

When we introduced our 672A "dream equalizer" in 1979, we had an instant hit. Audio professionals loved its versatility and clean sound. Eight parametric EQ bands (with reciprocal curves) were combined with wide-range tunable 12 dB/octave highpass and lowpass filters. The result: an amazingly powerful and useful machine. A cost-saving one too, because the outputs of both filters are available to perform a full electronic crossover function.

The 672A now has a stereo twin — the new 674A, with all the power of two 672A's in a space-saving 5 1/4" rackmount package. Naturally, both equalizers are built to full Orban professional standards. That means industrial-quality construction and components, RFI suppression, a heavy-duty roadworthy chassis, and comprehensive backup support.

**orban**

Orban Associates Inc.  
645 Bryant St. San Francisco, CA 94107  
Telex: 17-1480, Cable: ORBANAUDIO



To the audio professional, when a compressor or limiter is needed to tame the potentially disastrous consequences of uncontrolled level or to create special effects, one name stands out as the best: UREI.

Studio Standards for more than a decade, the compressors and limiters from UREI have earned their way into thousands of recording, mastering, and broadcast installations around the world.

Because we built our reputation for unparalleled professional performance and quality with our compressors and limiters, we have continuously advanced their engineering and technology to offer more reliability, features and performance. When you need the fastest, quietest and most flexible gain control instruments available, you can be totally assured that these products will prove to you why they've earned the title — Studio Standard:

#### The Model LA-4

A single channel, half-rack unit with patented electro-optical attenuator. Featuring smooth, natural sounding RMS action, it offers selectable compression ratios, a large VU meter, adjustable output and threshold levels and stereo coupling.

#### The Model 1176LN

A peak limiter which features adjustable input and output levels; individual attack and release time controls; selectable compression ratios; switchable metering; and

stereo coupling. The 1176LN is the most widely used limiter in the world.

#### The Model 1178

A two channel version of the 1176LN in a compact (3-1/2 ) rack mounting design. Featuring perfect tracking in the selectable stereo mode, it additionally offers selectable VU or Peak reading meter ballistics.

From One Pro To Another — trust all your toughest signal processing needs to UREI.

# The UREI Compressor/Limiters



**UREI** From One Pro To Another

United Recording Electronics Industries  
8460 San Fernando Road, Sun Valley, California 91352 (213) 767-1000 Telex: 65-1389 UREI SNVY  
Worldwide: Gotham Export Corporation, New York; Canada: E.S. Gould Marketing, Montreal

See your professional audio products dealer for full technical information.

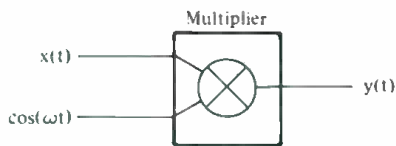

Figure 1. A multiplier with an introduced time variable.

the input produces trumpet-plus-violin at the output.

The mathematical notion of linearity is an abstraction because it assumes absolutely no distortion. But we know from practical experience that all systems will have some distortion, even if it is very small. This is the real difference between the mathematician and the engineer. The mathematician can imagine pure systems, the engineer knows that all real system have defects.

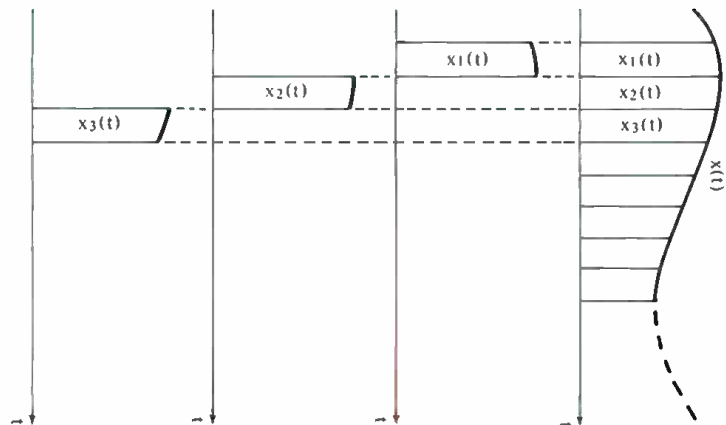

Figure 2. For filter design, an audio signal may be divided into a series of small slivers,  $x_n(t)$ .

## you write it

Many readers do not realize that they can also be writers for **db**. We are always seeking meaningful articles of any length. The subject matter can cover almost anything of interest and value to audio professionals.

You don't have to be an experienced writer to be published. But you do need the ability to express your idea fully, with adequate detail and information. Our editors will polish the story for you. We suggest you first submit an outline so that we can work with you in the development of the article.

You also don't have to be an artist, we'll re-do all drawings. This means we do need sufficient detail in your rough drawing or schematic so that our artists will understand what you want.

It can be prestigious to be published and it can be profitable too. All articles accepted for publication are purchased. You won't retire on our scale, but it can make a nice extra sum for that special occasion.



**Now, when you shake,  
rattle and roll,  
your microphone won't.**

**The Shock-Stopper™ from Shure.**

The amazing Shock-Stopper™ microphone mount from Shure. Whether you're on stage or anywhere else, this microphone mount significantly reduces mechanical and vibration noises.

It is available in both a half-circle version—literally a shock-mounted swivel adapter—for quick removal. Or, it comes in a full-circle design for vibration-free studio or stage instrument miking at any angle.

For more information on the A55 and A55 Series Shock-Stoppers,™ visit your Shure dealer, or call or write Shure Brothers Inc., 222 Hartrey Ave., Evanston, IL 60204. (312) 866-2555.

**SHURE®**

THE SOUND OF THE PROFESSIONALS®...  
WORLDWIDE

Circle 22 on Reader Service Card



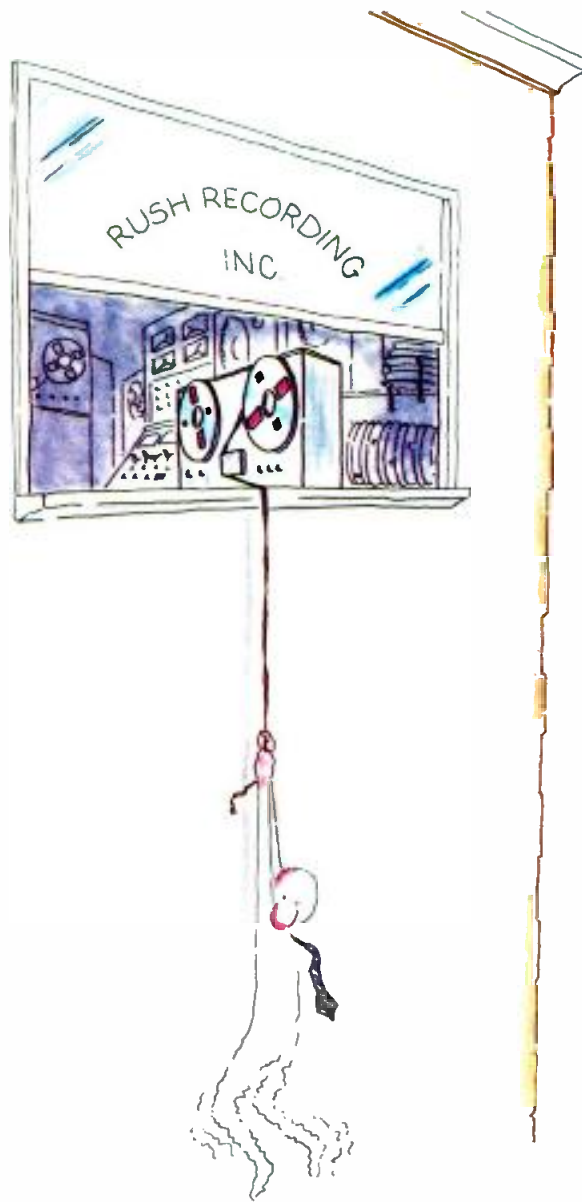

## Audio engineers who try Maxell won't let go.

Maxell quality saves a lot of recording situations. Maxell meets your 1/4" open reel and audio cassette needs, no matter how demanding you are. Because we're more demanding. We've developed a name that means unique quality all around the world. For example, Maxell cassettes give you a productivity boosting four-function leader with A/B side indications, directional arrows, non-abrasive head cleaner and five-second cue to set timing and level.

You can see Maxell excellence in the cassette construction and on the 'scope or meter. The physical construction is strong enough to meet all professional requirements. Maxell open reel tape and cassettes give you quality you can hear. And your clients can hear as well.

We'll give you all the technical information you need to form your own opinions. But if you're like just about every audio professional that tries Maxell, you won't let go. Remember, we warned you!



**maxell**<sup>®</sup>

PROFESSIONAL/INDUSTRIAL DIVISION

Our success is magnetic.

Maxell Corporation of America, 60 Oxford Dr., Moonachie, N.J. 07074 (201) 440-8020

Circle 26 on Reader Service Card

Like linearity, filters are also based on the notion of time-invariance. This is a more difficult concept. It means that if I place the signal  $x(t)$  into a system and  $y(t)$  comes out, then the signal  $x(t-T)$  as an input will produce  $y(t-T)$  as the output. In simple English, the system will do the same thing at 9:00 o'clock as at 10:00 o'clock. If the violin appears at the ampli-

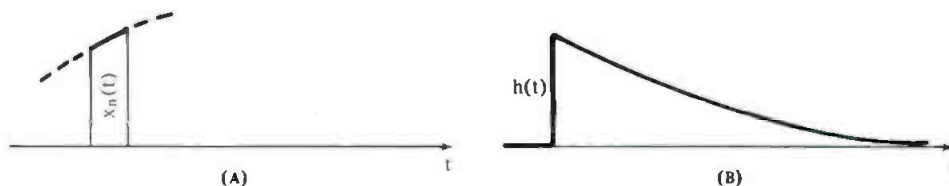

Figure 3. A typical filter output, for any of the input slivers seen in Figure 2.

fier input 1 hour later, then the output violin will also appear 1 hour later.

To use an analogy, a trip by automobile might be considered a time-invariant process: if I enter the automobile 1 hour later, I will get to my destination 1 hour later. In contrast, an airplane trip may not be time invariant since the schedule is fixed. Arriving at the airport 1 hour later may result in either arriving at the same time (if I can still catch the same plane), or arriving 3 hours later (if I miss that plane).

Another way of looking at this issue is by considering if time is local to the signal or is an absolute external reference. The automobile uses local time; the airplane uses absolute time (schedule). In FIGURE 1, the multiplier is not time-invariant since the relationship between the input and output is dependent on the time variable  $\cos(\omega t)$  in the multiplier. The output is

$$y(t) = x(t)\cos(\omega t).$$

If the input is delayed by one time unit then

$$y(t-1) \neq x(t-1)\cos(\omega t).$$

Thus, a multiplier is generally not a time-invariant process. Linearity and time-invariance are the only mathematical concepts necessary for filter design.

CONVOLUTION

To see how we might apply these concepts to filter design, we will begin by considering a piece of an audio signal  $x(t)$  as shown in FIGURE 2. If we wish, we can break this signal up into tiny slivers, each of which is very narrow. This allows us to say that

$$x(t) = x_1(t) + x_2(t) + x_3(t) \dots$$

Why have we done such an operation? The answer is that we will find an elegant way of looking at filters and some interesting properties of filters. To see this, we need to follow certain arguments.

First, break the input signal  $x(t)$  into a set of signals  $x_1(t), x_2(t), x_3(t) \dots$ . Mathematically we write this as  $x(t) = \sum x_i(t)$ , where  $i = 1, 2, 3, \dots$

Now, consider a filter which produces an output  $h(t)$  when a single input sliver appears at the input. This is illustrated in FIGURE 3.

The single sliver which produces the output  $h(t)$  completely defines the filter!

With an API totally modular console by Datatronix, you have unlimited flexibility in size and function. Each console is custom designed... each component individually selected by you. After all, the choice is yours... you design the console to fit your needs today and tomorrow. □ For example, you can choose from five different, interchangeable, plug-in EQ modules and an array of input and auxiliary modules—all assembled into a mainframe designed to your requirements. As your needs change, so can the modular components. Plus... each console may be prewired for expansion, so that you can easily expand your capability at minimum cost! □ The API console by Datatronix offers you the quality of sound, performance, and flexibility you demand as a professional recording engineer. So call us today... and remember the choice is yours.

**With an API modular console, the choice is yours.**

**Performance you can count on**

**DATATRONIX INC**  
A subsidiary of ATLANTIC RESEARCH CORPORATION  
2100 Reston Ave., Reston, VA 22091 (703) 620-5300 TWX 710 833 0365



Moreover, we can find the filter's response to all inputs just by knowing the response to this one case. To do so, we need the two principles of linearity and time-invariance. Linearity says that if I know the response of the system to  $x_1(t)$  and to  $x_2(t)$ , then I will know the response to  $x_1(t) + x_2(t)$ . In other words, I can get the response of the filter to the complete signal by adding the responses to each of the slivers.

The response  $h(t)$  to the first sliver is scaled by the amplitude of that sliver. The second sliver is like the first sliver except that it has a different amplitude and it appears 1 time unit later. Hence, its output must also be scaled and it must appear 1 unit later.

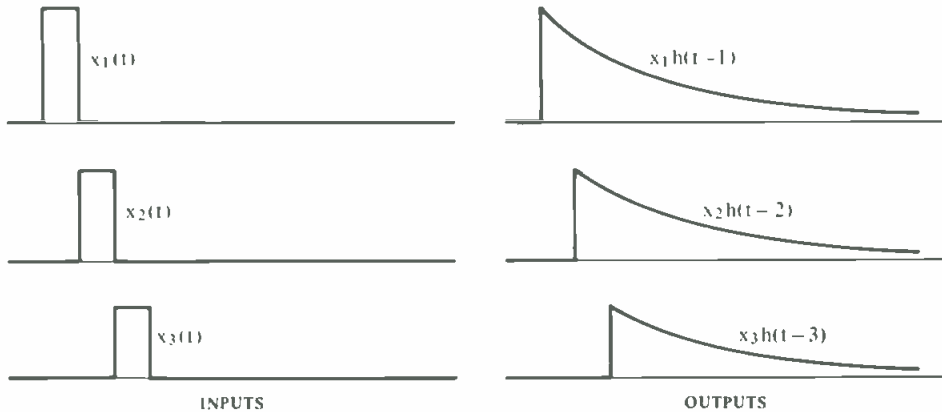

Figure 4. The filter outputs for a series of input slivers.

FIGURE 4 shows this process. On the left we have the input signal  $x(t)$  decomposed into its slivers. Each sliver has an amplitude corresponding to that part of the signal from which it was taken. On the right we have the response to that sliver. This response has an amplitude which is determined by the input sliver amplitude and a time function which is  $h(t)$  delayed by the delay of the sliver. The  $x_4(t)$  sliver begins 4 time units after 0, hence the output response must also begin 4 units later. This is the time-invariance argument. The linearity argument says that the sum of the signal responses on the right must be the actual signal which would come from the full input.

Mathematically, this summation can be written as

$$y(t) = \sum [x(j) \cdot h(t-j)].$$

There are several interesting things to note about this. First, the response to any input signal can be determined if we know the response to a single sliver. This is called an "impulse response," since the mathematical definition of a sliver is an impulse. Secondly, by computing the above summation, we have a systematic way of determining the response to a signal. This activity is called *convolution*. Unfortunately, solving this summation is usually very difficult. Fortunately, it is only necessary to appreciate that it *could* be solved and that the linearity, time-

invariance arguments are necessary for the solution.

In our further discussions we will refer to a filter only in terms of its impulse response rather than its implementation. For example, the impulse response of the circuits in FIGURE 5 is given by

$$y(t) = Ae^{-t}$$

Here we have two different implementations with the same impulse response. Hence, they are identical from a mathematical point of view. They will produce the same outputs for the same inputs. One may be better or worse from an engineering point of view but not from a mathematical point of view. The impulse response is thus a very compact notation for describing filters.

## TYPE VS IMPLEMENTATION

When we talk about designing a filter, we must be careful to separate the design of the impulse response from that of the implementation. Both are important. Sometimes a given impulse response is extremely difficult to implement. The impulse response above has a certain frequency response. We must ask, "Is that the response we wish?" If it is, then we must ask about a good way to implement it.

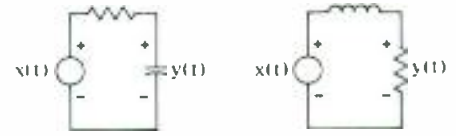

Figure 5. Two circuits which give the same impulse response.

When somebody says that he needs a 9th-order Bessel filter, he is using the language of type with no regard to implementation. Similarly, he could have specified a 19th-order elliptic. As it turns out, this one is very difficult to implement because it requires a stage with very high Q. Mathematics does not concern itself with a Q of 500. However, the mathematics to compute the impulse response of a 19th-order elliptic may also be difficult. Many computers do not have enough accuracy for such computations. Even 20 decimal digits may not be enough. Nevertheless, the difficulties are not directly comparable.

This article has mixed the discussion

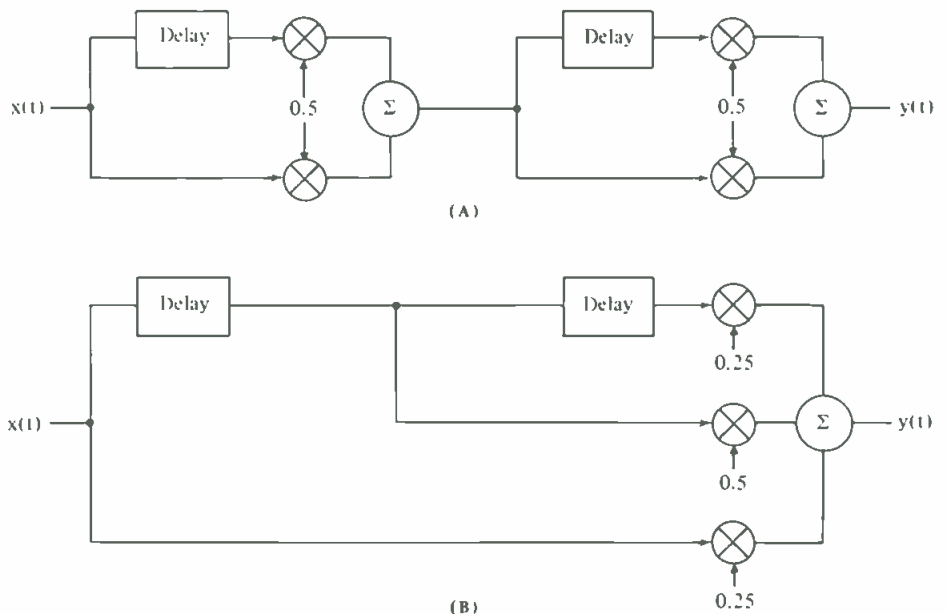

Figure 6. Two practical filter circuits which produce the same impulse response.

The same argument can be made for a digital filter. FIGURE 6 shows two different implementations which have the same impulse response.

We can say that these are identical. From an engineering point of view, however, there are subtle differences relating to truncation noise in the multiplier.

between analog and digital indiscriminately because the issues are the same. Just as a resistor, capacitor, and inductor are linear time-invariant elements, so are scaling, delay, and addition. The kinds of impulse responses which can be achieved are different. The mathematics are the same.

## Babylonian Astronomy and Digital Filters

• Mathematicians went through a lot of chalk in the eighteenth century. Following the invention of calculus by Newton and Leibnitz, there was a burst of activity in topics of mathematical physics. There was a critical need to better understand physical phenomena with mathematical precision, a need that has continued to this day in every profession—yes, even audio. One of yesterday's hot topics of controversy continues to be of critical importance today: the method of representing complex functions, such as waveforms, with simple functions, such as sine waves.

The boundary-value problems of vibrating strings, and bars or columns of air, led eighteenth-century scientists to associate mathematical theories with musical tones. It seemed natural to think of functions arranged much like musical tones are as mathematical multiples of each other. The ideas seemed simple enough, and they were, but to reach an under-

standable result required the unification of diverse research in vibrating strings, planetary action, and finally the conduction of heat. Even then, the conclusion reached was met with skepticism and today, it still sometimes seems to breed more confusion than enlightenment. But if math geniuses fumbled over it for fifty years, what do you expect from us mortals?

### BATTLING SCIENTISTS

Scientific heavyweights d'Alembert, Euler and Bernoulli were aggressively concerned with the study of the vibration of a string fixed at both ends. Both d'Alembert and Euler obtained equations in essentially identical forms which explained the string vibration as the superposition of two waves travelling in opposite directions—you pluck a string, and it's actually two opposite waves. But d'Alembert thought the initial form of the string could be given by a single ana-

lytical expression, whereas Euler thought of it as a continuous curve with a different analytical expression for each part. Then Bernoulli gave the solution in the form of a trigonometric series which, being general, subsumed the other theories. Euler got excited, and wondered if *any* function could be expressed as an infinite series of multiple sine waves: he decided it would be impossible—sines are periodic and odd, they would only work with periodic and odd functions.

Then a young and upcoming mathematician, Lagrange, in defending Euler from d'Alembert, proposed a new look at the problem. He hypothesized that a string could be considered as an infinite number of particles stretched on a weightless line. He solved the associated equation with a series of sines and cosines. If he had taken one step more, and changed the order of summation and integration in his solution, then instead of talking about Fourier functions all the

## Only Swintek GIVES YOU A CHOICE

in wireless microphone systems

- Choice of mics—Beyer M500, Shure SM57, SM58, SM78, SM85
- Choice of finishes—chrome, black chrome or gold
- Integral antenna or rubber duckie
- Systems for hand held mics, lavalier mics, electric instruments or ENG/EFP/LPTV

Unsurpassed field-proven reliability assures the high audio quality that professionals demand. VHF high band and narrow RF signal bandwidth permit numerous systems to be simultaneously used on nearby frequencies without interference or receiver desensitizing by local TV or radio broadcast signals. All metal construction assures durability and RF shielding. dB-S companders permit wide dynamic range without unnatural compression. Swintek—the proven performers.

**Swintek**  
TELECOMMUNICATIONS DIVISION

1180 ASTER AVENUE, UNIT J / SUNNYVALE, CA 94086  
(408) 249-5594 / TELEX 172-150 SWINTEK SUVL





# "Right On The Money!"

Harvey presents the Soundcraft SCM762  
24-Track with nine position autolocator.



16 Track from \$19,050.  
24 Track from \$21,250.

The true job of any pro sound dealer is to help you find the equipment that is *exactly* right for your needs. Harvey thinks Soundcraft may be just that kind of equipment. Designed to eliminate costly manufacturing methods, Soundcraft equipment nonetheless preserves every last ounce of the sound quality and reliability you demand in your operation. Offering outstanding specs, ready user and service access and rock-solid construction make the SCM762-24 the right machine at the right price from the right dealer. Harvey.

# HARVEY

TOLL FREE:  
1-800-223-2642

25 W. 45th St., NEW YORK, N.Y. 10036 (212) 921-5920

time, we would be calling them Lagrange functions—but that gets ahead of the story.

Separate from their disagreements about vibrating strings, Euler and d'Alembert were also disagreeing about—take a deep breath—the astronomical problem of the expansion of the reciprocal of the distance between two planets in a series of cosines of multiples of the angle between the radii. Both men presented the idea of using a definite integral to find the series coefficients, that is, the constants that specify which simple functions represent the complex function, and Clairaut published a paper detailing the integrals needed. Still, no one thought of linking these new integrals with the work on vibrating strings, and the theory

of trigonometric series remained unresolved.

#### FOURIER TO THE RESCUE

Then, in 1811, Fourier presented a paper to the Paris Academy on his Mathematical Theory of the Conduction of Heat—*Theorie Analytique de la Chaleur*—still a classic in heat conduction. He proved that certain simple functions which he needed to explain the conduction of heat can be represented on a bounded interval by series of sine and cosine functions and, perhaps more importantly, he asserted that any piecewise smooth function can be expanded into a trigonometric series. This was nothing new, but he was the first to assume almost carelessly, that a series could be found for

any arbitrary function—and *that* was his distinct advance. Everyone was surprised, and skeptical—even Lagrange flatly denied that it could be done. Fourier was met mostly with scorn, and he left it to others to later prove his contentions—he was more interested in applications and methods, not conditions of validity. It wasn't until Dirichlet presented a proof in 1829 that Fourier's theory became secure.

So, Fourier finally nailed down the idea that a continuous function can be represented by an infinite trigonometric series. Calculator-brains out there will clearly recognize the famous result showing the infinite series of sines and cosines:

$$f(t) = A_0 + \sum_{n=1}^{\infty} (A_n \cos n\omega t + B_n \sin n\omega t)$$

Suddenly math was a lot easier, and complex functions could be quickly analyzed and better understood. Ever wonder just what's going on inside that trumpet tone? Fourier will tell you *everything* (almost) you want to know. That complex periodic function can be analyzed as harmonic component frequencies—the trigonometric form is the Fourier series for the function, and the process of determining the values of the constants is called Fourier analysis.

The values of the constants can be informative in themselves. Symmetry around the x-axis will give a zero value for the constant. If the function is even, all the sine terms will be missing, and if odd, the cosine terms will be zero. The familiar formulas for determining the constants are probably also easily remembered by calculator-brains (check a deeper memory level):

$$A_0 = \frac{1}{T} \int_0^T f(t) dt$$

$$A_n = \frac{2}{T} \int_0^T f(t) \cos n\omega t dt$$

$$B_n = \frac{2}{T} \int_0^T f(t) \sin n\omega t dt$$

Let's look at an example, and one difficult in the respect that it requires a long series to be accurately represented. The familiar saw-tooth waveform can be defined mathematically like this:

$$f(t) = \alpha \left(1 - \frac{2t}{T}\right)$$

If that function is substituted into the three equations to determine the coefficients, we find the results:

$$A_0 = 0, A_n = 0, B_n = \frac{\alpha}{n\pi}$$

And the complete harmonic series representing a saw-tooth wave can be written:

$$f(t) = \frac{\alpha}{\pi} (\sin \omega t + \frac{1}{2} \sin 2\omega t + \dots + \frac{1}{n} \sin n\omega t)$$

That might not look like much, but it offers a relatively easy way to mathematically represent a saw-tooth sound. And that's a real opportunity—instead of working with the actual signal, we can work with the numbers that comprise it—just like a digital system.

There's a lot of information contained



# SOUND UNSEEN

## THE BEYER MCE 5

Voice and appearance are key to a news announcer's success. Beyer benefits both with its MCE 5 electret condenser mic. A matte-black omni so tiny it's virtually invisible. Full 20-20,000Hz range projects the vital presence of the speaker, uncolored, undistorted. Unique floating element eliminates clothing noise. Removable windscreen for outdoors. 62dB S/N. 116dB overload. 700-ohm balanced output for professional performance. Phantom or self-powered, also available in a variety of connector configurations to meet every application requirement, including wireless.

Visit your local Beyer dealer today.



beyer dynamic

BEYER DYNAMIC, INC.  
5-05 Burns Avenue, Hicksville,  
NY 11801 • (516) 935-8000



# The Bose® 402 Loudspeaker.

The professional standard  
for small-group P.A. systems.

**N**ow Bose brings the advanced technology of the Articulated Array™ system to a speaker designed specifically for high-quality reinforcement of vocals and acoustic instruments. The 402 Professional Loudspeaker. An affordable and truly portable alternative to the traditional small-group P.A. speaker.

Each 402 enclosure contains four 4½" high-sensitivity drivers mounted on a faceted 3-dimensional baffle. This unique Articulated Array™ system works together with a special Acoustic Diffractor and built-in Directivity Control circuitry to deliver exceptionally uniform room coverage, without the penetrating shrillness of horns or the muffled sound of columns.

Tuned Reactive Radiator slots allow the 402 speaker to produce surprisingly high output levels with low distortion. The matched 402-E Active Equalizer assures smooth, accurate spectral response across the entire operating range of the system. And the TK-4 Transit Kit lets you clamp a pair of 402 speakers (with equalizer) together into a compact unit light enough to carry in one hand!

The 402 Loudspeaker makes it easy for anyone to

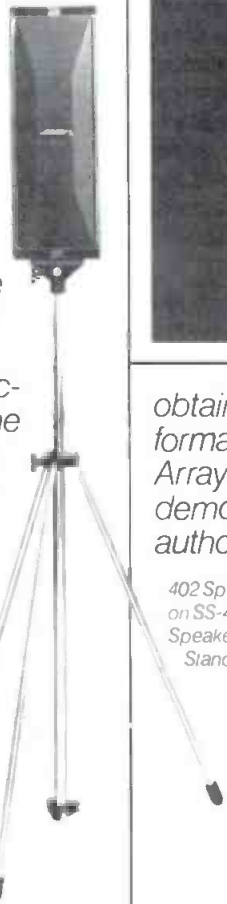

obtain the outstanding performance of Bose's Articulated Array™ system. Ask for a live demonstration at your authorized Bose Professional Products dealer.

402 Speaker on SS-4 Speaker Stand



402 System Set in TK-4 Transit Kit

Bose Corporation, Dept. MR  
The Mountain  
Framingham, Massachusetts 01701

Please send me a copy of the Bose Professional Products Catalog and a complete dealer list.

Name \_\_\_\_\_  
Address \_\_\_\_\_  
City \_\_\_\_\_  
State \_\_\_\_\_ Zip \_\_\_\_\_  
Telephone ( ) \_\_\_\_\_

**BOSE**  
Better sound through research.

© 1982 Bose Corporation. All rights reserved. No part of this publication may be reproduced without the prior written permission of Bose Corporation. Printed in the U.S.A.

here. For example, if a function consists of a certain number of sine and cosine vibrations, then the analysis will contain only that many terms. Analysis of a beat tone will contain only two terms. The more complex the vibration, that is, the more abrupt the discontinuities, the more terms needed to accurately represent the functions. In the case of a square wave or saw-tooth, an infinite series must be considered to gain equivalence. Practically speaking, acoustical vibrations are usually fairly well behaved and convergence is rapid. Only a relatively few number of terms must be considered. In the case of the saw-tooth, perhaps ten or twenty terms would add up to the same vibration, sharp teeth and all. Of course, it should be mentioned that the Fourier theorem can be used in reverse too. A linear combination of simple vibrations which have commensurable frequencies forms a complex vibration at a greatest common divisor frequency: we can synthesize complex tones from simple ones. Need a string section? How many sine wave generators on your test bench? Don't laugh—Stockhausen realized some of the world's greatest electronic music with that trick. And more than a few digital synthesizer manufacturers have picked up where he left off.

That idea of a harmonic and partials is an incredibly important one, as anyone who has ever heard music will attest. Consider the fact that if a low frequency

pure tone is sounded first as a low and then a high loudness level, most perceivers will state that the second tone has a lower pitch, despite the fact that the frequency has not changed. However for complex tones (say, from acoustic musical instruments), that perceived change in pitch is much smaller because, as Fourier analysis reveals, even if the fundamental lies in a pitch range subject to that decrease, the harmonics will have frequencies for which the pitch changes very little, or perhaps increases. That annoying dependence of pitch on intensity is compensated for by a dependence on waveform.

#### TIME AND FREQUENCY

Finally, let's mention the Fourier duality of time and frequency. We can display a function in time, and we can also look at it by frequency, that is, as a spectrum of the time signal. The process of Fourier transformation allows us to freely switch from the time domain to the frequency domain and back. Those transform functions are incredibly important. Once again, information is the name of the game. It was in the eighteenth century and it still is—only more so.

That ability to switch from one domain to the other as applied to digital implementation—remember, that is where numbers derived from our mathematically precise methods can really be utilized—allows us to approximate con-

tinuous transform functions with DFT (Discrete Fourier Transforms). The high speed algorithm (great for high speed computers) for computing the DFT is the FFT (Fast Fourier Transform). We can use that FFT to find out all kinds of things about a waveform: How about instant spectral analysis? Easy. Or, if we smooth the data with a window function before we compute the FFT, we could digitally filter the function. And that is a great idea. The filter is dynamic—it can be programmed. Any time an analog function has been converted to digital form, these Fourier methods are ready to analyze and process—the chance for some extremely complex and accurate audio processing is at hand. Those old phase-shifting, distorting equalizers made of resistors, capacitors and inductors? Get rid of them. It can all be done with beautiful, absolute analytic precision and grace.

So—the discussion of quarrelling eighteenth century scientists led to a general theory for representing functions, which makes it easy to mathematically analyze and process those functions, which has led us to digital filters—to the promise of the digital mixing console.

Oh—if only for the sake of completeness, the ancient Babylonians deserve most of the credit. Thousands of years ago, their astronomical computers were already using summations of sines and cosines to predict celestial events. ■

# THE ULTIMATE.

Did you ever dream of a mike that never lies? Never adds, never subtracts? Not even at 130 dB SPL? Well, this is it. LC 25. The transformerless line level condenser. The only one of its kind.



**MILAB**™

Manufactured by CTAB, S-265 00 Åstorp, Sweden PROFESSIONAL MICROPHONES

BELGIUM Trans European Music 02 569 18 23 · FINLAND Studiotec 90 556 252 · FRANCE MCI France 1 227 25 95 · GERMANY EMT-Franz 07825 1011 · HONG KONG Studer Revox 5-412050 · JAPAN Continental Far East 03 583 8451 · NEW ZEALAND General Video 4-872-574 · NORWAY Pro-Technic 02-460554 · SPAIN Singleton Production 2283800 · SWITZERLAND Audio Bauer 01 64 32 30 · UNITED KINGDOM AVM Audio Video Marketing 0632 893092 · USA west Carr International 213 821 7898 · USA south Swedeks 404 881 9981 · USA east Facel 212 370 0032

Circle 30 on Reader Service Card



# In search of the ideal mixer.

In demonstrating our microphones throughout the country, we've found a serious limitation in most stage mixers. They are unable to handle wide range microphones on stage. And they just can't cut it when it comes to making demo tapes. Which means that the musicians need TWO mixers and perhaps TWO sets of microphones to get the sound they want on stage as well as on tape. It's a luxury not everyone can afford!

So, to solve your problem — and ours — we set out to create a "double threat" mixer which would be a great stage mixer, yet still give you the sound and control you need while taping. A mixer designed to take full advantage of every mike you own, including phantom-powered models.

Our standards (like yours) were high. Everything had to be rugged, reliable, and very clean. With wide basic frequency response, plenty of headroom, and very low distortion and noise. And the mixer had to be very natural to use. Finally, the price had to be right. We invite you to examine the new Audio-Technica ATC820 and ATC1220 stereo mixing consoles to see how well we have accomplished our goal.

Our prototypes have done a lot of traveling. Users were impressed with the features, the flexibility, and the sound. They liked the 3-band EQ on every input. And the 7-band stereo graphic program equalizers, plus another graphic equalizer for the monitor output. But most appreciated were the variable high-pass filters for each output. They permit you to use wide-range recording microphones on the stage, while exactly limiting bass response to suit acoustics and to keep from overloading your speakers. Yet during recording you can go all the way down to 20 Hz if you wish.

There's a long list of very practical features. Phantom power is available at each of the transformer-isolated mike inputs. Two 20 dB mike input pads plus an LED to warn of clipping on each input. A SOLO button to check any input with headphones without affecting the mix. "Stackable" design when 8 or 12 inputs aren't enough. Even an assignable talk-back input. And all the logical controls for the transformer balanced MONITOR, EFFECTS, SOLO, PHONES, and OUTPUT

busses. In short, very flexible, and quite complete.

With a very modest investment, you can do almost everything the single-purpose boards can do... and do it very well. And get the benefit of phantom-powered recording mikes on stage as well as during recording. The more you learn about the ATC820 and ATC1220 the more impressed we think you'll be. Ask your Audio-Technica sound specialist for a hands-on tour of this brand new breed of mixer. Or write for literature. We may have the ideal answer to your mixer requirements.



audio-technica®



AUDIO-TECHNICA U.S., INC., 1221 Commerce Drive, Stow, Ohio 44224 • (216) 686-2600

Circle 27 on Reader Service Card

# db Sound With Images

## Pro Video Borrows Consumer Tape For New VTR Format

• Last April, RCA's Commercial Communications Division introduced a new video recording format. They also submitted the new system as a proposed standard to the SMPTE (Society of Motion Picture and Television Engineers). One aspect of this new system is its use of half-inch videotape, housed in standard 250 meter (E-120, 2 4 6 hour) VHS format videocassettes. RCA calls the new system Chroma Trak, and they are already using it for ENG (Electronic News Gathering) and other video recording applications where light weight and portability are important factors.

The group of products related to the new Chroma Trak system are part of RCA's new "Hawkeye" product line. As illustrated in FIGURE 1, a pair of HR-2 Hawkeye videotape recorders are controlled by a Model HF-1 edit controller in the studio. A combined camera video recorder, Model HCR-1 (not shown), for in-the-field use has also been developed, as have separate cameras and portable video recorders using the new format.

### WHY NOT VHS OR BETA?

If you aren't intimately involved with videotape recording, you may be wondering why professional video production houses didn't simply modify either of the two popular consumer videotape formats to suit their needs. After all, VHS and Beta VCRs also use half-inch wide tape and many of the new portables now available for these popular systems are amazingly sophisticated and, at the same time, light enough to meet the needs of video professionals who must often carry their equipment for long periods of time and into inhospitable environments. While both VHS and Beta VCRs are amazingly intricate and technologically advanced video systems, the truth is that the picture and sound quality that they deliver is simply not good enough for broadcast use. Remember, in broadcast applications the videotape that's actually sent out over the air may well be a few generations removed from the original tape shot by the news crew, which only serves to further degrade the quality of both picture and sound. If you doubt it, just look at the picture produced by a 2-inch wide videotape system (or even the 1/4-inch U-Matic system used by most small professional video production houses) to appreciate what good video color pictures can look like—even when limited by the U.S. NTSC standards.



Figure 1. Products developed by RCA for the Chroma Trak video recording system include the two recorders shown flanking an edit controller.

Better still, addition a laser-type video disc, using a good TV monitor and you'll see pictures having a video frequency response up to 4.0 MHz or more, as against response that rolls off quickly above 2.0 MHz in both the Beta and the VHS home videotaping formats.

### CHROMA TRAK'S ADVANTAGES

Even compared with 1/4-inch U-Matic, the color quality of the new Chroma Trak system is dramatically better. Freedom from color noise, streaky colors and even improved color purity is very apparent. Chroma Trak has twice the information-packing density of U-Matic. Translated to visual terms, this greater packing density means greatly improved picture quality. Chrominance (color) resolution is more than three times as great as in a 1/4-inch video system. Chrominance signal-to-noise ratio is improved by approximately 10 dB. Chrominance-to-

luminance (brightness) registration is improved by a factor of more than 3-to-1. Luminance small-image detail is maintained, affording a sharpness of picture not previously obtainable except in wide-tape studio machines. Perhaps best of all, the Chroma Trak signals are designed to be recorded on standard, familiar VHS cassettes which are readily available and reasonably priced, compared with other exclusively-professional tape packages.

### HOW CHROMA TRAK WORKS

Basically a *dual-track* helical-scan system, Chroma Trak records the *luminance* video signal on a track 7 mils wide, while the color signal is recorded on an accompanying, parallel track 2.5 mils wide. These side-by-side tracks are laid down by a pair of heads mounted very close to each other (See FIGURES 2 and 3). Each track is 3.7 inches long and, taken together, they contain information

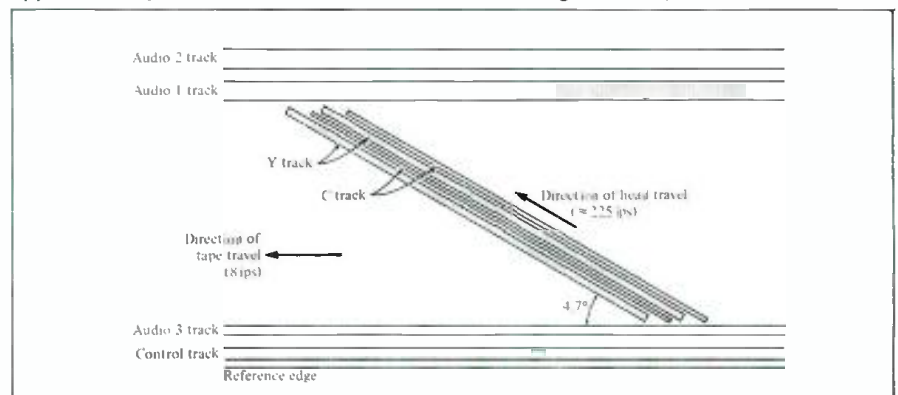

Figure 2. Track layout for Chroma Trak format.





# SONEX

## FOR CLEAN SOUND

After WLEE installed SONEX, people called about the "clean, new sound!" Was it new equipment?

No. The answer is simple and inexpensive:

SONEX kills all the stray reflections, so the mike processes a clean signal of the announcer's voice. The announcer hears himself in a warm environment, and there's

less clutter to waste watts. The result is a noiseless, clear signal and greater market penetration.

Get the facts today. SONEX is available in five colors, in three thicknesses, and in standard four-ft. square panels. Use it in broadcasting, recording, videotaping or performing areas for really pure, clean sound.

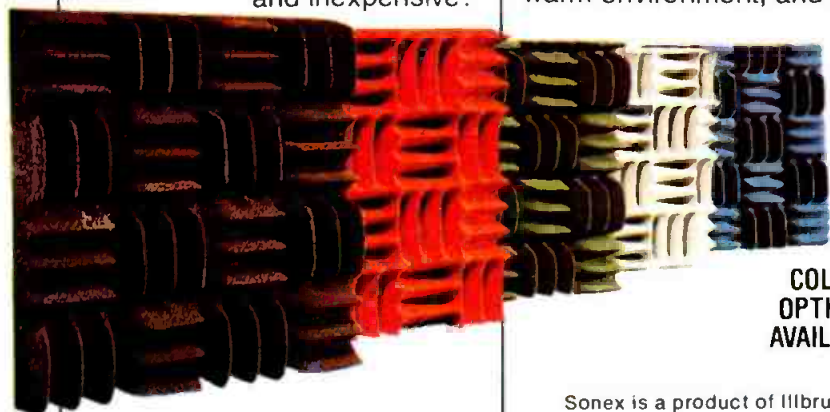

**COLOR  
OPTIONS  
AVAILABLE**

Sonex is a product of Illbruck/USA

**Alpha  
Audio**

2049 West Broad Street  
Richmond, Virginia 23220 (804) 358-3852  
*Acoustic Products for the Audio Industry*

*Circle 32 on Reader Service Card*

for one complete field of video. The tape is wrapped 180 degrees around a drum which is rotating at 29.97 revolutions per second. The drum is 2.44 inches in diameter. There are four longitudinal tracks in addition to the angled video track-pairs. Tracks 1 and 2 are used for audio (stereo is taken into account), track 3 may be used for time code for post-production editing and audio synchronization, and track 4 is the control track.

Now, here comes the important additional difference between consumer-type VHS video and the Chroma Trak system. Longitudinal tape speed of the new system is 8 inches per second, or more than six times as fast as a VHS tape system operating at its fastest (SP/2 hour) speed. A T-120 videocassette will therefore provide about 20 minutes of record play time. Since the main purpose of the system is for use with cameras (as in remote news-gathering operations), this should not prove too much of a problem. And in any event, if more recording time is needed in the field, the cameraman can simply pop in another VHS cassette. All of the remotely-shot videotape will be electronically edited before broadcast anyway.

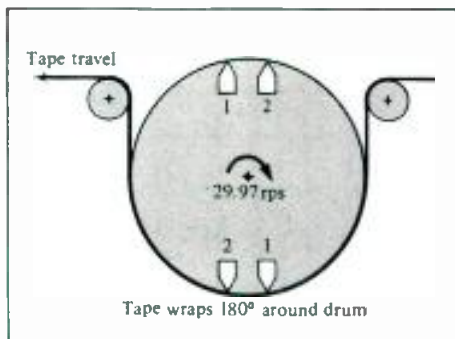

Figure 3. The drum containing two pairs of luminance and chroma heads rotates in the same direction as the linearly-moving tape.

#### MAKEUP OF SIGNAL ON THE TAPE

Effective head-to-tape "writing speed" works out to be about 225 inches per second and, since the Chroma Trak system boasts a recording capability of 27,000 Hz per inch, that means a bandwidth capability of slightly in excess of 6 MHz! When tied in with a "Hawkeye" camera/recorder system, pure luminance (Y as well as separate chroma I and Q) signals are derived *directly* from the camera encoding matrix system. When a camera is not used, a comb-filter type of decoder derives separate Y, I and Q signals. The three separate signals are converted to frequency modulation prior to being recorded onto the tape. The Y signal causes FM deviation from 4.3 MHz to 5.9 MHz (peak white signal) and occupies a band which extends out to about 10 MHz. Because this signal is purely monochrome, strong color subcarrier systems which have caused moire-pattern interference in other video recording schemes are totally absent.

The I and Q color signals are also converted to FM. The I signal deviation or modulation is from 5.0 to 6.0 MHz,

#### PICTURE QUALITY COMPARISON

|  | Hawkeye | ¼ inch   |
|--|---------|----------|
| Chrominance Resolution                     | 1.0 MHz | 0.3 MHz  |
| Chrominance Noise-SNR                      | 48 db   | 38 dB    |
| Chrominance Registration<br>3rd Generation | 90 nsec | 300 nsec |

Figure 5. Picture Quality Comparison.

while Q color signal deviation is from 0.75 to 1.25 MHz. After suitable preemphasis these signals are combined by simple addition, and fed to the color track of the tape. The I FM signal is at a level high enough to serve as the record bias for the lower-level Q signal, which is recorded linearly.

Several of the problems that have plagued previous videotape recording systems are eliminated with this system. We have already mentioned the elimination of the moire-pattern thanks to the fact that the luminance and chrominance channels are separately laid down on the tape. In addition, since there is no subcarrier on the color track to be time-modulated by jitter, there is a complete absence of visible noise streaks often seen on other video recording systems. Furthermore, since differential phase and gain are a result of intermodulation between chrominance and luminance signals, the Chroma Trak system, which separates luminance and color signals, does not suffer from these additional signal faults. Although RCA's description of the Chroma Trak system says nothing about audio fidelity of the sound tracks of the new system, it doesn't take much calculation to realize that tape moving at 8 ips is going to yield a lot better audio fidelity and signal-to-noise ratio than it does moving at the standard VHS tape speed of 1.31 ips or the Beta speed of 0.79 ips.

The chart shown in FIGURE 4 shows how video recording densities have improved since the first video recorders were produced more than two decades ago. Recording density is shown in cycles per inch of tape-to-head writing speed, and the new RCA Chroma Trak system is compared with the popular U-Matic ¼-inch tape system and with earlier systems such as Type C, Quadruplex and Quad. The table shown in FIGURE 5 presents a

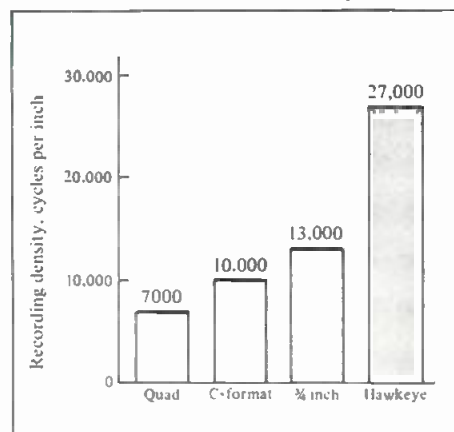

Figure 4. Comparison of Recording Densities.

comparison of picture quality between the RCA Hawkeye system and the popular U-Matic system with regard to color resolution, video signal-to-noise ratio, and color-to-luminance registration. As the table shows, the major improvement is in the *quality* of color offered. In more technical terms, chrominance noise has been reduced by more than 3 to 1. This translates to a 10 dB improvement in measured noise, and an even more noticeable improvement in the subjective effect. Chrominance-to-luminance registration has been improved by more than 3 to 1. Finally, in the luminance signal itself, small-image detail is preserved, which tends to eliminate the "cartoon" look found on many current ¼-inch VCRs.

#### EASE OF EDITING

Earlier tape systems, which placed the color subcarrier on the actual composite videotape recording, forced the editor to worry about color framing when editing. The freedom to choose points at which to edit was therefore limited to one of four fields. Chroma Trak, which completely eliminates the subcarrier from the tape itself, allows editors to choose editing points with the same freedom that existed years ago, before the advent of color. Also, the chance of making a bad color-field edit, with its attendant "jump left" or "jump right" is totally eliminated. According to RCA, Chroma Trak has been enthusiastically received by a large number of producers, directors, editors and technical personnel who have reviewed its specifications and observed its performance.

#### AUDIO PARAMETERS

In writing the specifications for their proposal, RCA spelled out the specs for the audio signal tracks. Recorder reference level for 0 dB, using a 1 kHz test signal, is specified as 100 nWB/m tape flux per unit track width and a standard volume level indicator (per ANSI/IEEE Std. 152-1953-R1976) is also called for. The Audio 1 track (in FIGURE 4) is assigned for mono audio. For stereo audio, audio track 1 is designated as left channel while audio track 2 is right channel. The time code track may also be designated as a third audio track.

With the video industry seeking to standardize a ¼-inch (8 mm) format for consumer use, one wonders whether the half-inch videotape formats now so popular in consumer circles may not, some day, become "strictly-pro" tape formats as video technology continues to progress. ■



# OUT NOW!!

The latest editions of two important and well respected reference books on sound and television broadcasting and engineering.  
**AN ABSOLUTE MUST FOR THE BUSY PROFESSIONAL.**



|                                       |  |  |
|---------------------------------------|--|--|
| <b>PRO AUDIO<br/>YEARBOOK 1982/83</b> | 138mm x 216mm<br>660 Pages (Approx)<br>ISBN 0-900524-98-7<br>Casebound | Over 600 Black & White Photographs<br>ISSN 0260-8537 |
|---------------------------------------|--|--|

The **PRO-AUDIO YEARBOOK** is an annual guide to products and services for engineers and technicians operating in the world of professional recording and sound broadcasting around the world. Published in hardback and containing over 650 pages, it contains sections covering every conceivable pro-audio requirement. In addition to the many product sections, there are sections covering Engineering and Consultancy Services, Jargon and Journals, Computer Services and Training, and an important section providing full details of Mains Power Supplies in almost 200 countries. The 1982/3 edition of the **PRO-AUDIO YEARBOOK** has been completely revised and updated, providing even better coverage of the ever expanding pro-audio market.

|                                   |  |  |
|-----------------------------------|--|--|
| <b>VIDEO<br/>YEARBOOK 1982/83</b> | 138mm x 216mm<br>660 Pages (Approx)<br>ISBN 0-7137-1144-2<br>Casebound | Over 600 Black & White Photographs<br>ISSN 0140-2277 |
|-----------------------------------|--|--|

To anyone engaged in the business of communicating via television, the **INTERNATIONAL VIDEO YEARBOOK** should need no introduction.

This lavish publication has, over the years, become an institution to the buyer of television equipment or services around the world.

The first part contains over 70 separate sections covering every conceivable type of video equipment ranging from cameras, through Monitors, Effects, Editing to Video Recorders. In addition there are new sections covering Airborne Video, Satellite Stations, Antenna and Masts, Video Hard Copy and Portable Audio Mixers, and of course the renowned International Television Standards section.

The second part of the book contains the indexes, cross referenced to the product sections, and giving full addresses, phone and telex numbers and principal contact for over 2,500 companies in the video and related industries around the world.

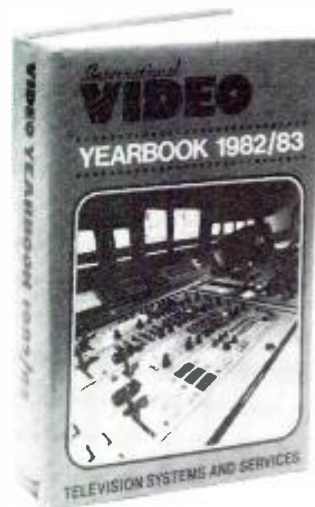

Please fill in the coupon and return with remittance to:  
**Sagamore Publishing Co, 1120 Old Country Road, Plainview, New York 11803, USA.**  
 (In NY State, add applicable sales tax)

**PLEASE SEND**

copies Pro-Audio Yearbook 1982/83 @ \$54.00 each

copies Video Yearbook 1982/83 @ \$54.00 each

(All Prices include Surface Delivery. Please add \$7.00 per book For Air Mail)

Please charge my Access American Express Diners Club Mastercard Visa card number (please delete as appropriate). Card holders address must be used

Card No.....  Please send by Air Parcel (see above)  I enclose a cheque for .....

Please return the completed order form enclosing your full remittance (including delivery) or giving your credit card number, to:

**Sagamore Publishing Co, 1120 Old Country Road, Plainview, New York 11803, USA.**  
 (In NY State, add applicable sales tax)

Name .....

Company Name .....

Address .....

Phone Number .....

Signed .....

# The Power of Communication

From a Complete Mixing System.



**MARK IV™ MIXING CONSOLE**



**MARK IV™ MONITOR**

*Features and specifications subject to change without notice.*



It is the purpose of any musical performance, live or recorded, to successfully communicate with the listener. To attain that goal is often a challenge — even for the most experienced musicians, sound personnel, and stage crew. At Peavey we realize the criteria to be met before this goal can be obtained.

### **MARK IV™ MONITOR MIXER**

First, the musician must be satisfied with the blend and balance of the on-stage monitor mix. In most concert type situations, the musicians may demand anywhere from two to six separate monitor mixes. Our new Mark IV™ Monitor Mixer can supply this need with up to eight individual monitor mixes.

The Mark IV™ Monitor Mixer is available in 16 x 8 or 24 x 8 configurations and features transformer balanced inputs and outputs, 8 unbalanced outputs, PFL/Solo headphone system, 10-segment LED ladder displays for each of the 8 outputs, auxiliary inputs and low-cut controls for each mix and a unique PFL/Solo patch. The PFL/Solo patch is a highly desirable feature that enables the monitor engineer to patch any of the mixes back into the switched inputs so that externally equalized or processed signals can be monitored. This is a feature which is not usually found on custom-made monitor mixing systems costing \$15,000 or more.

Each channel of the Mark IV™ Monitor Mixer features LED status indication of -10 dBV and +10 dBV, an input gain control, 4-band equalization, built-in mic splitter, phase reversal switch, PFL and mute switches, and 8 color-coded rotary level controls which correspond to color-coded slider level controls in the output section.

To make the most out of the Mark IV™ Monitor Mixer's capabilities, we have equipped the mixer with two separate built-in communication systems. By utilizing our optional headset or "gooseneck microphone," the monitor mix engineer can communicate with the musicians through any of the 8 separate monitor mixers. This

talkback system will help alleviate the problems musicians sometimes have in establishing the proper on-stage mix, especially if a previous sound check was not possible.



**MARK IV™  
OPTIONS**

A second communication link can also be established by the monitor mix engineer between the stage crew and lighting personnel by utilizing the optional Talk/Comm "slave" units. The Mark IV™ Monitor Mixer's front panel utilizes an LED indicator to alert the engineer as a call function and also shows when intercom is active.

### **MARK IV™ MIXING CONSOLE**

Next, the house (main) system must be able to deliver crystal clear, noise-free sound reproduction to the associated equalizers, power amps and horn/loudspeaker enclosures. For the main PA, our new Mark IV™ Professional Mixing Consoles offer the sound engineer the necessary performance, flexibility and functions to do almost any sound job.

The Mark IV™ Professional Mixing Consoles are available in 16 or 24 channel versions (16/24 x 4 x 1) and feature transformer balanced inputs and outputs, PFL headphone system, 10-segment LED ladder display for all outputs, channel and sub output LED indication (-10 dBV and +10 dBV), internal reverb and effects/reverb return to the monitors. The console also utilizes a 24 volt phantom

power supply, variable low-cut controls on each sub (20 Hz to 500 Hz), and in-line patching facilities between the sub outputs and the sum.

Each channel of the Mark IV™ mixing console features an input gain control, two pre-monitor sends, 4-band equalization, effects/reverb send control, pan control, "push/push" channel assignment switches, pre and post EQ, send/reverb patching and PFL (pre-fade listen) switch.

The Mark IV™ Professional Mixing Console has two complimentary communication systems for use with our Mark IV™ Monitor Mixers, headsets, gooseneck microphone and Talk/Comm "slave" units. The Mark IV™ Series intercom system allows communication between the "house" and monitor mix engineers as well as stage, lighting and other associated concert personnel.

Both the Mark IV™ Monitor Mixer and the Mark IV™ Professional Mixing Console feature gooseneck lamp connectors (BNC) with dimmer controls for use with our optional gooseneck lamps. This option allows superb visibility of the mixers in poor lighting situations.

The Mark IV™ Series Monitor Mixers and Professional Mixing Consoles are the successful result of our extensive research and development efforts as well as constant "monitoring" of the needs of professional sound reinforcement companies and soundmen. This outstanding series of mixers represents, we believe, truly exceptional and professional products that will outperform competitive products retailing for many times the price.

For complete information on the Mark IV™ Series write to: Peavey Electronics Corp., P.O. Box 2898, Meridian, MS 39301.



PEAVEY ELECTRONICS CORP.  
711 A Street Meridian, MS 39301

© 82

## Combining HF and LF Elements

• The first six columns in this series have dealt with the building blocks of sound reinforcement loudspeaker systems: low-frequency components, high-frequency components, and dividing networks. In this month's column, we will see how these components are specified to meet certain performance criteria and how they are matched.

In general, it is best to stick with a single manufacturer in arraying loudspeaker components, since it is likely that a given manufacturer's items will work together with minimal compromise. Although good interchangeability exists between like items made by several manufacturers, only experienced designers should attempt to "mix and match" between manufacturers.

As examples of how systems go together, we will consider two designs: a high-level music monitoring system and a speech reinforcement system for a large auditorium. In working out these examples, we will be making two kinds of sound pressure level calculations:

1. Fixed distance, variable-power input. The equation for this is:  $\text{Level (dB)} = 10 \log (P/P_0)$ , where  $P$  is the input power and  $P_0$  is the reference power.
2. Variable distance, fixed-power input. The equation for this is:  $\text{Level (dB)} = 20 \log (D/D_0)$ , where  $D$  is the distance from the loudspeaker and  $D_0$  is the reference distance. This last equation is an example of the *inverse square* relationship, where sound pressure level is observed to fall off 6 dB per doubling of distance from the sound source in a free field, one essentially free of reflections.

### MUSIC MONITORING SYSTEM

The specification is given here:

1. A two-channel stereo system must be able to deliver sustained levels of 105 dB at a distance of 3 meters in a relatively-dead acoustical environment.
2. The system bandwidth must extend from 30 Hz to 18 kHz.
3. The system must exhibit uniform horizontal dispersion of 90 degrees above 1 kHz.

Generally, the low-frequency portion of a system sets its outpost limits, so let us begin with those requirements. Typical low-frequency transducers made for monitoring systems have a 1-watt, 1-meter sensitivity of about 93 dB and a thermal power input rating of 150-200 watts. Such a transducer would be ca-

pable of generating the following levels:

| Input Power (watts) | Distance (meters) | Level (dB) |
|---------------------|-------------------|------------|
| 1                   | 1                 | 93         |
| 10                  | 1                 | 103        |
| 100                 | 1                 | 113        |
| 150                 | 1                 | 115        |
| 150                 | 3                 | 95.5       |

Employing two loudspeakers in stereo would add 3 dB to the overall level capability, bringing it up to 98.5 dB. However, we are still about 6.5 dB shy of what we need.

Let us employ a *pair* of low-frequency units in each stereo channel and see what

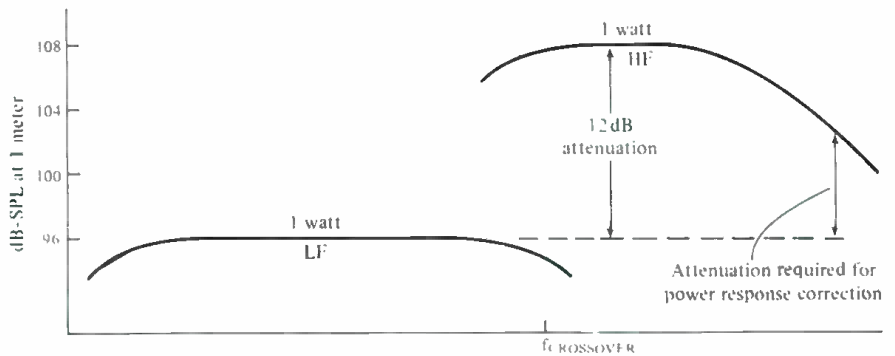

(A) DRIVE REQUIREMENTS

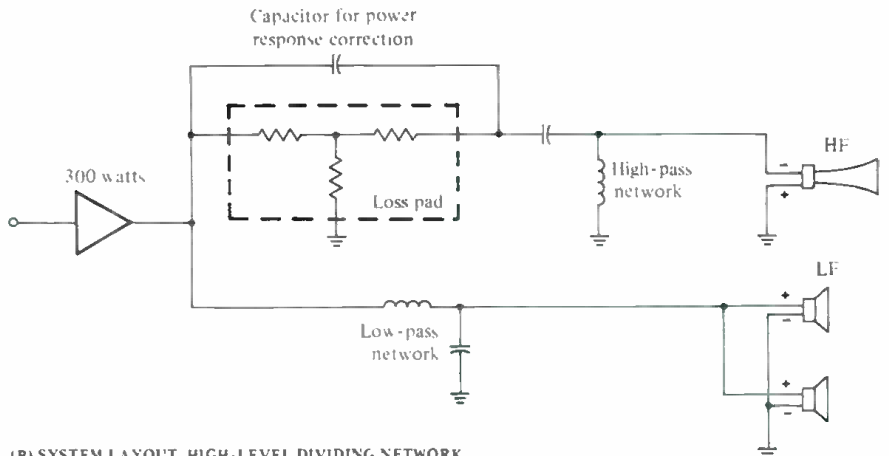

(B) SYSTEM LAYOUT, HIGH-LEVEL DIVIDING NETWORK

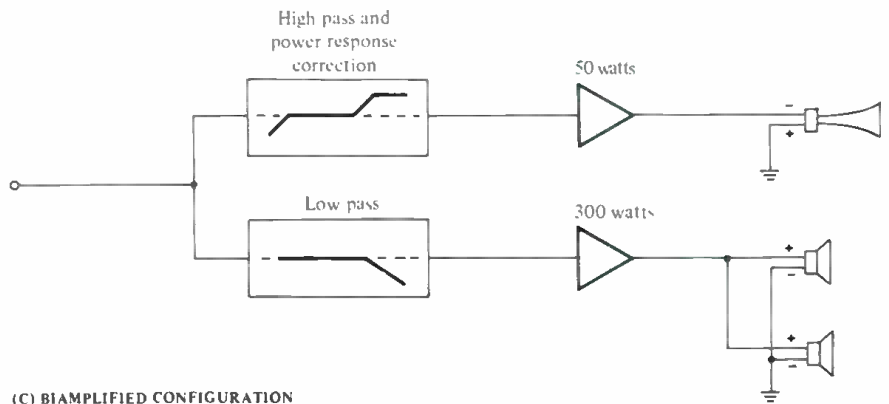

(C) BI-AMPLIFIED CONFIGURATION

Figure 1. A High-level music monitoring system.



the resulting capability is. A pair of low-frequency units can obviously handle twice the input power of a single unit, and this will result in a 3 dB increase in level capability. In addition to this, we have the phenomenon of *mutual coupling*, in which a pair of low-frequency transducers behave as a single *larger* transducer, increasing the output capability by another 3 dB. Thus, using a pair of low-frequency transducers in each channel and driving each channel with 300 watts will produce a combined level of 114.5 dB at a distance of 3 meters. This is sufficiently close to our requirement of 115 dB, and the low-frequency design is satisfactory.

Ported low-frequency enclosures should be used for maximum performance in the 30-35 Hz range. Enclosure volume should be chosen so that 30-Hz tuning of the enclosures gives smooth response. Here, a knowledge of the Thiele-Small parameters of the driver would be essential.

We have designed this system around the continuous input power capability of the drivers. In practice, there should be more power available, since drivers of the caliber used here would be capable of handling peaks at least 3 dB greater than the continuous power rating.

The high-frequency demands are relatively simple. For a crossover frequency of 800 Hz, there are a number of radial horns, constant coverage horns, and horn-lens combinations which have excellent 90-degree horizontal coverage. Typically, these devices, coupled with their appropriate high-frequency drivers, exhibit sensitivities of about 108 dB, 1-watt at 1-meter. Accordingly, the high-frequency part of the system will be

padding, or attenuated, significantly to match the low-frequency part of the system, and this is shown in FIGURE 1. A mid-band attenuation of 12 dB reduces the effective high-frequency sensitivity from 108 dB to 96 dB so that it matches the sensitivity of the low-frequency pair of drivers. Note that, at mid-band frequencies, one watt at the high-frequency input results in only  $\frac{1}{8}$  watt reaching the high-frequency driver; therefore, system power input of 300 watts is safely reduced to about 38 watts, well within the rating of a typical high-frequency driver.

If a constant coverage high-frequency horn is used, then there should be some degree of power response correction above 3 kHz. This is shown in FIGURE 1B in the form of a bypass capacitor around the loss pad. This of course results in more power being available for the high-frequency driver, and care must be taken that excessive high-frequency program does not enter this driver. Here, the choice of a smaller  $\frac{1}{2}$  cm diaphragm driver or a larger 10 cm diaphragm driver becomes important, because of the greater power handling capability of the latter.

If the system were to be stressed in the high-frequency range, then it might be appropriate to go to a three-way design, crossing over to compression tweeters above, say, 8 kHz.

Most manufacturers provide networks with the requisite loss and frequency division for matching the components of the system described here. Some provide, in their networks, the required high-frequency boost for correcting power response as well. FIGURE 1C shows the bi-amplified form of the system, which is preferred in terms of overall lower dis-

tortion. Manufacturer's recommendations regarding component placement and polarity (phasing) should be carefully followed for optimum performance in the crossover region.

Finally, we have ignored the effects of room reflections on output level. Even in a relatively-dead environment there would be some reinforcement in overall level, perhaps as much as 2 or 3 dB.

## SPEECH REINFORCEMENT SYSTEM

The requirement here is for a single-channel system capable of producing peak levels of 100 dB at a distance of 30 meters. For this application, a large low-frequency ported double-horn system would be a logical choice, since high output capability below 100 Hz is not required. A typical enclosure loaded with medium-sensitivity, high-linearity low-frequency drivers will have an overall sensitivity of perhaps 105 dB, 1-watt at 1-meter, and will be able to handle 400 watts of input power. Level calculations are given below:

| Input Power (watts) | Distance (meters) | Level (dB) |
|---------------------|-------------------|------------|
| 1                   | 1                 | 105        |
| 10                  | 1                 | 115        |
| 100                 | 1                 | 125        |
| 400                 | 1                 | 131        |
| 400                 | 10                | 111        |
| 400                 | 30                | 101        |

As we note, the low-frequency ported double horn easily fits the requirements. Again, we are discounting any increase in level due to reflected sound in the room.

Turning our attention to the high-frequency part of the system, let us assume that a 90-by-40 degree nominal coverage pattern will be appropriate. A typical constant coverage horn for this purpose coupled to its recommended high-frequency driver will have a sensitivity of about 113 dB, 1-watt at 1 meter. FIGURE 2A shows the basic drive relationships for the system. Note that the high-frequency section is padded 8 dB relative to the low-frequency, and this means that the power reaching the high-frequency driver will be just about one-sixth that presented at the input. Therefore, a 500-watt amplifier driving this system would never present more than 80 watts to the high-frequency driver. This is within the range of a typically "ruggedized" 10 cm diaphragm high-frequency driver, and the system should be "coasting" most of the time.

FIGURE 2B shows how the system would be laid out. No flat power response would be called for here, since it is customary to roll off speech-only systems above about 2 kHz at the rate of about 3 dB, octave. While bi-amplification would improve system performance, it would not be necessary in such a system as this. ■

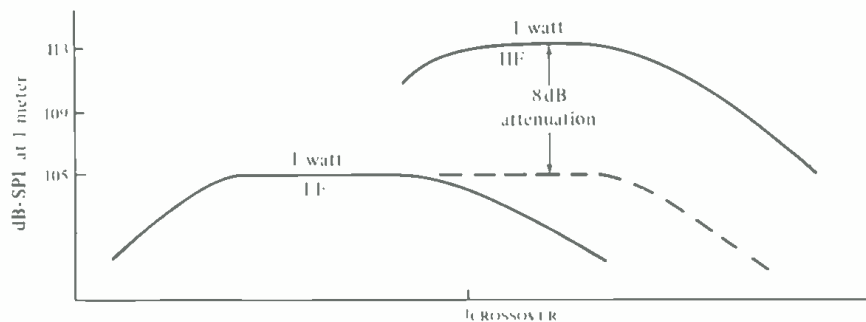

(A) DRIVE REQUIREMENTS (CROSSOVER TYPICALLY 800 Hz)

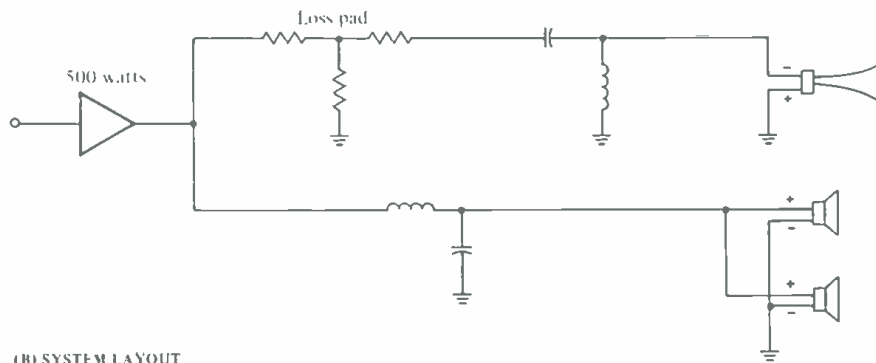

(B) SYSTEM LAYOUT

Figure 2. A Speech reinforcement system.

## Where there's smoke, there's an editorial

SOMETIMES THIS PAGE is easy to write. Sometimes it's not. Sometimes, it seems there isn't a fresh thought within miles of this typewriter. (*It couldn't be the typist.*)

Or so it seemed one Friday afternoon, when the publisher strolled by and hinted gently—as only a publisher can do—that time was slipping away. He expressed his concern subtly: “Where the hell is your *Sci&#* editorial!?”—or words to that effect.

As the reverberation died away, the phone rang (maybe it was ringing all the time), offering a chance to escape from all of this, *and* perhaps to return with an editorial as well. The caller represented an insurance firm investigating a damage claim for a truckload of audio hardware that was just barbecued, some 1000 miles from here.

In less time than it takes to say “double indemnity,” we were off to the airport and, not that much later, wading through the earthly remains of a Ford F-700 truck, searching for traces of a vanished sound system. Still later the same day (actually, very early the next), we were back home again, with an instant suntan, some very dirty clothes, a few rolls of depressing pictures, and enough fresh thoughts to fill up at least some of this page.

As we all know, fires are one of those little inconveniences that happen only to other people, who should have known enough to be prepared. The trouble is, many of those other people think that they too are immune from disaster, which is known to happen only to still other people. Every now and then, reality intrudes, as it did to the once-proud owner of this mess, who was now glumly picking through the rubble, looking for salvageable traces of his empire.

Fortunately, he had a first-class policy, and an insurance representative was on the scene almost as the smoke cleared. Contrary to what the ads imply, the agent was not shovelling money into the insured's pockets, but was methodically gathering what evidence he could to arrive at an equitable settlement. Fortunately, a detailed inventory of almost 20 pages was available (just like yours, right?). The insurance company had insisted on this list some time ago, when the policy was first issued.

Now, all that remained was to find sufficient trace of the major items on the list to verify that they were indeed on the truck before (and more important, *during*) the fire, and, that they were worth what was being claimed.

Some 90 percent of the items were no problem to find. Even in their new charcoal enclosures, the speaker systems were recognizable (not pretty, though). Multi-pair microphone cables, now the texture of fettucine,

were also easy enough to verify.

In the middle of the heap, a Calzone equipment case seemed to have survived both the fire and the fire department. With some anxiety, the case was opened and there sat the owner's favorite Tektronix scope, a trifle damp but otherwise none the worse for the experience. Time out for a minor celebration, in the midst of mourning.

Now comes the hard part: a major claim for lots of dollars-worth of custom-designed hardware. But how much is a custom-built black box worth? The price of the components may be negligible but the price of the idea behind them may be beyond calculation. The price of the finished product, when (and if) it reaches the market will be somewhere in between.

If it's that commercially-available speaker system, a few will know the actual value of the components. Still fewer will know just how much development money went into it. But everyone knows the market price tag.

Now let's look at your handful of charred components. A parts catalog will tell anyone who cares that we're looking at say, \$127.50 worth of scorched resistors, ICs and such. But what catalog will tell us their worth, once you've molded them into some wondrous new machine? How much will you claim for this mess? How much will the insurance company want to give you? The two figures may not be even close.

Perhaps it's not a black box full of hardware after all. Maybe it's just a white box, full of 24-track master tapes. How much is that worth? It's at about this point that the chummy relationship between you and your agent starts showing some signs of wear.

On the off-chance that he really wants to help you, consider his problem, if you can forget about your own for the moment. He's got to convince some bean-counter back at the home office that this junk is worth the millions you claim, and not the petty cash that everyone else says it's worth.

Do you have a good photo, taken before the disaster? Is there a schematic available? Have you already sold one, or something similar, to a satisfied customer? Has an independent outside source recently visited your lab, studio, or whatever? Can such a source verify the approximate worth of your gear? Do you have receipts for goods purchased?—for goods sold?

If the answer to most of these questions is “No,” you may be in for some rough going. Oh, not *you*, to whom such disasters never come; we meant the others. Maybe you'd better warn them, before it's too late. JMW



Like father,  
like son.

For roughly \$10,000, you can own the ultimate analog mastering deck—the Studer A80RC half-inch two-track recorder.

Beyond your budget? Well, for about 1/5 the price you can own a Revox PR99 compact professional recorder. It's made by the same company, it draws on the same wealth of engineering expertise, and it reflects the same philosophy of design and construction—a philosophy established by Willi Studer over three decades ago.

The PR99's bloodlines are evident in every detail...in the precision-machined headblock, the rugged die-cast chassis, the servo-controlled capstan motor, and the Studer-made heads. Professional design features include a flat faceplate for easy head access; edit switch to defeat tape lifters and fast wind latching; tape dump button; balanced XLR inputs and outputs switchable for calibrated or uncalibrated mode; and two-way self-sync with auto input switching. The PR99 may be ordered with 3¾-7½ or 7½-15 ips tape speeds. Vari-speed, full remote control, and monitor panel available as options.

The PR99 now comes in console, rack mount and transportation case versions. Check it out. Call or write today for the location of your nearest dealer.

The PR99. From the world's most respected name in recording.

**STUDER REVOX**

STUDER REVOX AMERICA, INC. • 1425 Elm Hill Pike • Nashville, TN 37210 • (615) 254-5651

*Circle 34 on Reader Service Card*

SHERMAN KEENE

# The Soundstream Digital Music Computer:

*Digital recording is said to have reached the beginning of its own era—and if the Soundstream Digital Editing Facility is any indication—it has...*

**E**ACH COMPANY ENGAGED in digital recording equipment manufacturing has gone a slightly different way in developing the mechanism of digital encoding, the computer codes used, and the features of the machines they make. For example, some companies have developed digital editing by the technique of actually cutting the digital master tape with a razor blade. Digital multitrack machines

exist with punch in/out capabilities (allowing overdubbing) and machine-to-machine digital mixing has been developed even including digital equalization which does not require dropping back to analog. Soundstream, on the other hand, has more or less bypassed the competition by not competing at all in those areas of digital sound development which are hold-overs from analog multitrack recording techniques. Rather, Soundstream has aimed squarely at simplicity, super-high audio quality, and reliability in their recording machines. They have, however, developed a complex editing system, which is way ahead of its time and its competition.

*Sherman Keene is the author of Practical Techniques for the Recording Engineer.*

## BORN IN THE STUDIO,



### THE TOA RX-7 SERIES



# Recording, Editing and Beyond

## TALKING TO HAL

Soundstream has developed a "blue box" which houses their exceptional digital circuitry. The digital information is then recorded using a stock, off-the-shelf, Honeywell instrumentation recorder. Using Soundstream electronics and Honeywell transports, the company offers two-track, four-track and eight-track digital recordings. The operation of their machines is straightforward: when you record, you record on all tracks—no overdubbing. You can't record one track at a time and layer your production: the machine simply records an event—a live one or a mixdown from (hopefully) a digitally-recorded multitrack project. Then, you return to the control room of the Soundstream computer facility and begin a dialog with "Hal" (Hal, the computer—you know).

Hal allows you to digitally transfer your music into his random-access, hard-disk, computer-storage devices from

which you can accomplish any number of simple or vastly complex post-production tasks, simply by asking Hal (via computer terminal) that it be done.

The music storage capacity of two Soundstream computer disk-paks is 34 minutes of stereo music but, by simply switching one disk-pak while Hal is busy with the other one, an unlimited length of continuous music is possible. You can hear the polished, finished version of your post-production changes, improvements and corrections almost at once. If, upon hearing your alteration, you like the effect, you incorporate the new edit function into the music. Once entered into Hal's "edit table," the computer will be able to play the corrected version from now on.

Since the music is in digital form, sampled in 1/50,000th second (20  $\mu$ sec.) segments, you can be very precise about where you want a computer-orchestrated change to begin and end.

The most remarkable thing about computers (especially hard-disk, random-access computers) is the speed with which

# BRED FOR THE STAGE.

Crafted in Japan.  
Proven in The States.



TOA Electronics, Inc.  
480 Carlton Court  
S. San Francisco, CA 94080  
(415) 588-2538  
Telex: 331-332

In Canada:  
TOA Electronics, Inc.  
10712-181 Street  
Edmonton, Alberta T5S 1K8  
(403) 489-5511  
Toronto: (416) 624-2317

## CONSOLES 32X8, 24X8, 16X4.

Circle 35 on Reader Service Card

the computer can access the information (in this case, the musical section) the operator wants from literally trillions of information bits. Consider: a three minute stereo recording, on Soundstream's hard-disk would process 2 (tracks)  $\times$  3 (minutes)  $\times$  60 (seconds per minute)  $\times$  50,000 (samples per second) or 18 million digital samples. The Soundstream system uses a 16-bit digital word. One bit is a positive or negative waveform excursion "flag" and the remaining 15 bits indicate what value (amplitude) the waveform has above or below the zero-crossing line. Each digital word, therefore, can have a positive or negative value of the number 2 raised to the 15th power, which represents a range of music waveform values from +32,767 to -32,768 or a total range of 65,536 possible music waveform values stored for each track of music during each sampling. This would be 18 million (digital words)  $\times$  16 (bits per word) = 288 million digital bits of music waveform information carefully stored away for each 3 minutes of stereo music. To be sure that the computer does not lose any of these tiny information particles, health check-up is done each day, in which the computer performs a complex edit function and then goes back and checks itself, to see that it did not lose even so much as a single bit for the test piece of music.

The process of music production with the Soundstream system is: (1) record the original master tape from a live performance or the playback mix session of (hopefully) a multitrack digital project, (2) transfer this reel-to-reel recording to the disk system of the editor computer, (3) perform edits between takes, within takes and apply polishing touches (special effects, tightening ups, elegant cross-fades, etc.) to create the finished product and (4) have the computer—using the instructions created by the editing session—transfer the original music (modified by your editing changes) to a fresh reel-to-reel digital tape creating an edited digital master. This edited master tape can be copied, shipped, or carried to any disk mastering facility, dubbing facility or wherever it is needed. It is important to keep in mind that all copies of this edited master are of equal quality: there is no difference between the original and any generation following it, provided the digital tape recorder and player machinery is working properly.

The Soundstream disk storage area is divided into three partitions—a main region where the original music is stored, a scratch region where experiments are performed and the work region where edits, cross fades and the edit table are stored. Soundstream editing sessions never alter the original music itself. Instead, only tables of numbers are created by the computer in response to simple commands from the editor. The computer later uses this Edit Table to remind itself which takes were chosen, what edits were performed, what effects were decided upon, and where they all go in the music. Amazingly, the computer can think fast enough to do all these computations and perform all the required edits, while playing back the still physically unaltered music it has in its main region.

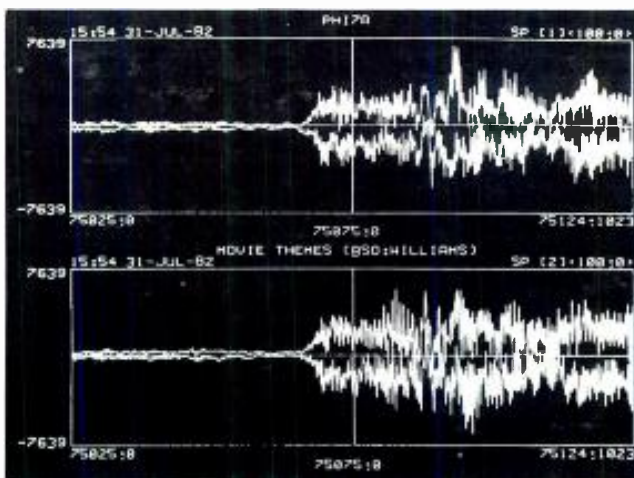

Figure 1. Display of stereo image. Duration: 75 records or 1.5 seconds. Room ambience leading to initial attack of program material.

When the computer is playing your music with the edits you have created, this is what goes on behind the scenes. The computer looks up which song is to be played first and, if there are no polishing adjustments to the intro area, begins by playing directly from the original music disk area (you can be taping this playback or just listening). It follows the original music stream in the main region while watching the work region for upcoming instructions on edits, fades, etc. When it comes to a place where an edit or other instruction is needed, it jumps to another disk location to pick up the proper music according to the instructions it left for itself in the edit table. No gaps in the music occur because of: (1) the extreme speed at which the computer "thinks," (2) the computer's ability to do several things at once (like spooling music data at the same time it is looking up the next edit task elsewhere on the disk) and (3) the use of the Buffer.

## THE BUFFER

The Buffer is an electronic device which lets the computer feed in data in chunks (the way computers like to supply information) while allowing the data (the music) to come out connected and smooth (the way humans like to hear it). Long before (long in the frame of reference of the computer, that is) the edited section is even played back, the computer has looked up the instructions necessary to jump out of the "play-edited-music" mode and has gone back to supplying original, unaltered music to the buffer or whatever its instruction table has told it to do. A short time later this original music section, smoothly joined to the edited section, comes out of the buffer and is heard. Thus, the computer's parts and pieces are connected into ultra-smooth music to be output to the listener.

What can you do with the editor? Well, here is an up-to-the-minute list of standard features: (1) butt edit, (2) cross-fade edit, (3) cross fade, (4) clone a sound, (5) readjust the levels of either or both sides of the edit, (6) edit or reposition one track while not editing any other, (7) visually investigate a music section to set an edit point by using the graphic display and the Bit Pad, (8) interpolate between two pieces of moderately or wildly different music data so that a "rough" splice which might never have worked using analog methods, can be made to work, (9) replace distracting ambience with more suitable ambience (or dead silence, if it is preferred) around dialog or other intermittent program.

## DEFINITIONS

By way of explanation of the forgoing list:

**Butt edit.** This is what the engineer does when he cuts an analog tape and edits the new head piece to the old tail piece. A big difference with Soundstream digital editing is that you can try moving the edit point forwards and backwards on both the head and tail piece in microscopic steps without actually damaging the tape as you would when trying this with actual tape. In addition, since the Soundstream system keeps a separate edit table and does not make edits by actually altering the original music, any edit can be re-done at any time without having to re-do the remainder of the musical program, as is necessary with machine-to-machine digital editing. Some tape-to-tape editing systems require you to re-do *all* edits from where you are until the song's end, should you decide to alter or add an edit within the song!

**Cross-fade edit.** A quick cross-fade at the edit point, between similar musical sections, to help the edit work smoothly. This is what you would get if you could manage a very long diamond-shaped razor-blade cut. The tail of, say, the first piece would come to a narrow point in the center of the tape, while the head of the next piece would form a long V-shaped notch. With such a remarkable cut, both stereo tracks would "slide" from the previous old piece to the edited-on new piece. This is, of course, impossible to do manually but very easy with the computer. A similar result might be achieved using analog methods at some loss of quality and patience by dubbing the two sections to be cross-faded to two SMPTE-controlled auxiliary machines. By finding the proper SMPTE offset, synchronizing the two machines and moving four faders smartly, one might be able to duplicate in 30 or so minutes a procedure which takes all of



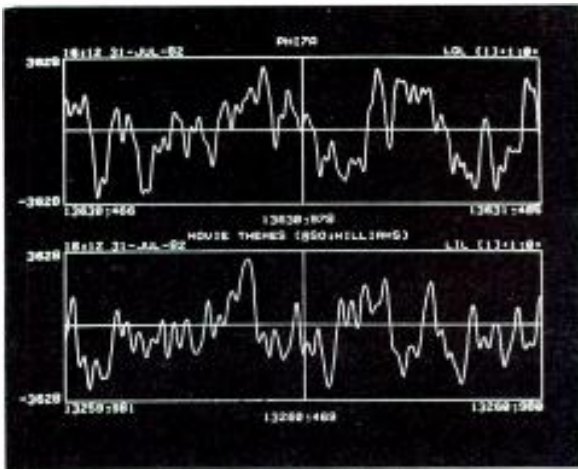

Figure 2 Display of left channel lead-out and lead-in locations. Duration: one (1) record or 1/50th of a second. Allows waveform comparison between takes at splice point. Assists in determining a smear width value to provide an inaudible splice.

several seconds to do by Soundstream's computer. This technique makes for beautiful-sounding edits because, in most cases, cross-fades are much more "invisible" to the ear.

**Cross-fade.** A transition between different musical programs; an alternative to the fade-to-silence and re-intro scheme of song-to-song transition. You can request a cross-fade from Hal, and hear it almost immediately. To be fair, long cross-fades (20 seconds and more) take a while to process because of the astronomical number of bits which the computer is intermixing for you while it is "away" doing its tireless bookkeeping. On the other hand, the computer's cross-fades are beautiful: crisp, clear, and the music comes back hard as nails. Since the music is blended digitally, you still have first-generation music quality (if your project has been completely digital, that is). Entire albums without a single "dull moment" are now possible by cleverly superimposing background sounds over introspective moments, adding crystal clear ambience and cross-fading between cuts or interludes.

**Clone a sound.** Something only the most energetic engineers have ever tried—usually because they had accidentally damaged a small piece of the master tape which they desperately needed to replace. They would do so by copying (cloning) a piece from another similar part of the master and "fudging" it into the position of the crumpled original piece. To clone at Soundstream, you indicate the time frame (a note, a bar, a phrase, etc.) you would like to clone, specify the number of times you want the computer to clone it and instruct Hal where you want the clone placed in the music. Several adjustments may be performed during cloning—like level match, duration trimming and entry and exit point manipulation. Remember, these location decisions can be assigned or moved around within the music to an accuracy of 1/50,000th of a second. Usually though, a wider edit-point window is more practical—something like 1/100th of a second or so.

**Readjust the levels.** Something which you just can't do while manually editing analog tapes (unless you want to drop a generation while experimenting with altered levels leading into or out of the edit, that is). The levels of the music at each side of an analog tape splice are set at mix time; if a fader gets accidentally bumped between mixes, then the mixes are not level-compatible and that's that. Even with digitally selectable edit points and cross-fade techniques, a difficult edit may still sound jarring until you try a level offset at the splice point. This level correction can be smoothed back to normal levels over a suitable time period, recouping any level lost or gained.

Note-by-note level adjustments can be made if desired. Suppose you had a piano solo recorded with a particularly rough passage which really taxed the performer. One of the notes in the passage was hit too softly. You can "invade" the existing piano recording note-by-note and re-set the level of any

note or notes to any level you like (by setting a new level parameter at the computer keyboard). Along these same lines, by cloning (to lengthen) or "nibbling" (to shorten), bits of a note you can adjust the LENGTH of any note of the piano solo, taking up the musical "slack" of gained or lost time elsewhere by simple arithmetic.

**Edit or reposition one track.** This would be like trying to edit or time-displace track 3 of an 8-track tape while not affecting tracks 1, 2 and 4 through 8. Try *this* one with analog tape and a razor blade! That's right, the computer doesn't mind if you want to tidy up the entrances of the background singers (on say, track 3) who came in late at each chorus. You can delete some silence prior to their entrance and add an identical quantity of silence elsewhere to square the time up again. If that doesn't sound too good, try deleting the opening silence and then lengthening the singer's first note by cloning it to just the right length so that their first phrase stretches out to where it used to end originally. If your sense of humor gets the best of you, you can "lay in" another word instead of the one they sang—substitute a noise or musical note—really, anything you can imagine, the computer will do. And if the computer's stock repertoire of features doesn't have a function the client wants, an emergency programming session in Salt Lake City may be feasible to invent the software needed to "fix it in the edit." This is the real power Soundstream has over its competition: their editing computer is almost infinitely expandable in its abilities, requiring only a good suggestion and a clever computer programmer to implement it.

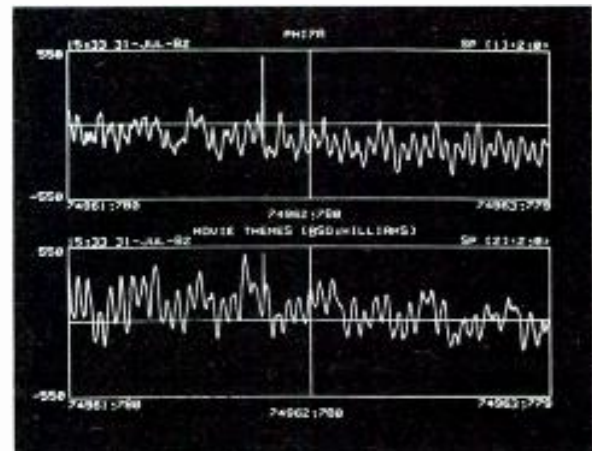

Figure 3. Display showing a click within program material. Scale is two (2) records or 1/25th of a second.

**Visually investigate** (in addition to listening, of course) a musical section to set an edit point. Have you ever done a sound check with dead quiet ambience only to hear a mysterious flurry of clicks and pops once the actual recording phase of the session begins? The Soundstream computer is a champ at cleaning up ticks, clicks and pops. You can use a graphic visual display, point out the little troublemakers to the computer, and let Hal get rid of them. You point out edit locations by using a Bit Pad in conjunction with the video display. The Bit Pad is a small magnetically-sensitive drawing board on which you "draw" with an electronic pencil. This method allows editing by eye as well as by ear. Editing begins by requesting that the computer "paint" a given time period of the musical waveform on a video display. Instead of typing in a flurry of instructions indicating the parameters of the edit, simply move a small indicator (about the size of a cassette) around on the Bit Pad while watching the video display. As the computer senses the signal from the indicator, it displays a bright dot on the screen along with the music display.

Now move this dot to the beginning of the musical waveform edit location you're interested in (by sliding the bit-pad stylus around) and press the bit-pad indicator button. Now, moving the bit-pad indicator dot to the exit point on the waveform, you press the button once again and the computer knows exactly

what you want to remove. All the edit-point information the computer needs is calculated automatically. The graphics which are displayed during this function are particularly beautiful and curious: a look at music from a heretofore unavailable point of view.

Since the music which was buried by the "pop" is invisible to the computer, the waveform values on either side may not line up. To just connect the two ends of the broken waveform with a straight vertical line would cause a "mini-squarewave" that would be nearly as audible as the pop which was removed. In order to connect the gap caused by the removal of a noise, one simply asks the computer to study the waveforms on each side of the gap, and interpolate.

**Interpolate** between two pieces of moderately or wildly different music data. If you try to splice two pieces of tape that really don't go with each other using the old analog method, you might try to make the edit work by shaving little pieces of tape off one or both ends of the splice area. After a little experimenting, your tape ends become so shortened that you can't even put the original music back together again, should you decide that the splice isn't going to work after all. This kind of analog hit-and-miss "fix-it" editing is particularly annoying. With the computer on your side, however, a splendid and complex mathematical computation is put to work to adjust the audio waveforms to match each other in spite of themselves. A software package was recently completed which automatically looks at the waveforms at either side of the splice and makes up a "best guess" as to what the removed waveform would have looked like. Thus, many pops can be removed, one after the other, without disturbing (shortening) the temporal quality of the music. This precision methodology seldom fails to work, and even if it shouldn't, there is still the battery of other functions which you can try.

All these methods can be tried on a particularly difficult splice in the time it takes to do even one "exploratory" splice with a razor blade.

A major record label, while in the process of archiving their analog tapes, found that hundreds of splices had crept apart. Once the music was entered into the Soundstream computer, these wayward splices were found and closed up. Both the archive original copy (with the gaps) and the archive repaired digital masters (with the gaps removed) are now stored away safe from the degradation which analog tape recordings suffer over long periods of time.

**Ambience Replacement.** This process is particularly annoying because you must edit around *every* note or word, replacing the original ambience with a more suitable or acceptable background sound. Consider a narration recording where two actors have an argument. The background ambience is totally quiet. Later, the producer re-records one half of the argument (one actor's part) and has these responses edited into the original recording. It is then that he notices that the edited master sounds artificial because when one actor speaks, there is

silence, while when the other speaks, there is (let's say) a water-running noise in the background. In order to proceed, the producer will have to cut the ambient tape pieces out of the "repaired" actor's recordings and replace these pieces with "dead" air to match the background of the original recording. What's even worse is if the entire original recording has (it is discovered later) unacceptable background ambience! Then all the silences between each word (or at least between sentences) must be replaced. At Soundstream, this process is quite simple, using the bit pad. The unwanted ambience can be either removed, creating dead silence between speeches, or the original ambience can be replaced with a suitable background sound borrowed from another recording.

## BLACK BOXES AND DIGITAL MIXERS

Digital music from other manufacturers' digital tape machines can also be loaded into the Soundstream computer for editing. This is possible because the computer has a "black box," containing a user-adjustable sampling frequency converter which can be set to whatever value is needed to properly read the foreign digital information. These digital tapes can now be edited with all the power of the Soundstream software brought to bear on them. Once fully edited, the finished music may be transferred back to the host recording machine for further use in the outside world.

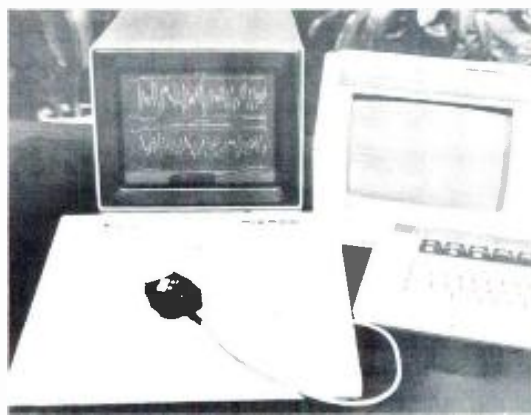

Figure 5. The bit pad and storage scope display

Soundstream is now working on new hardware to enable their editor and tape machines to act in a "slave" role for SMPTE synchronizer work. Adding this feature to their equipment will open up a whole new field of work to them including advanced video sound and digital sound for film work. Also, they are hard at work to perfect a remarkable, inexpensive digital playback device for the home which uses a thin plastic card as the music storage medium. The music is recovered from the card by a laser. (More on this AudioFile card system in a later issue of *db* Ed.)

I would like to close with an incredible Soundstream story illustrating their ability to respond to special circumstances. For the old Caruso masters which Soundstream worked on, they invented a really amazing computer program to restore naturalness to the sound of the music which had been originally recorded onto disk through a megaphone. Megaphones (mounted backwards—large end toward the music) were once used to concentrate the sound so that it would properly vibrate a diaphragm which then cut the music onto a wax disk. This made everything sound horn-like. Soundstream taught the computer the actual physics of sound passing through a horn and then instructed the computer to work backwards—to "dehorn" the sound. It worked.

My special thanks to Jim Wolvington (chief pilot of the Soundstream editing computer) and Gregg Stephens (chief technical engineer) in Los Angeles and to Bob Ingebretsen (a company Vice President) and Dane Brewer (electronic engineer extraordinaire) in Salt Lake City for their time and cooperation. ■

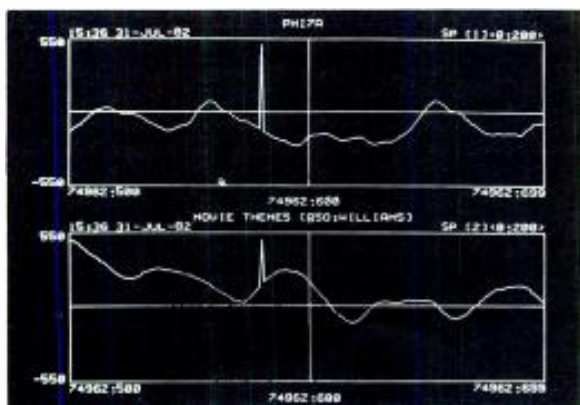

Figure 4. Expanded view of #3 with a scale of 200 samples or 1/250th of a second. Allows for either precise location of edit points or interpolation points for removal



# The Man Behind Soundstream

*The potential for absolutely superb audio fidelity offered by the use of digital methods can be completely lost in the A-D and/or D-A converters employed unless some basic, but not-so-obvious, performance specifications are met.*

THESE WORDS ARE FROM an abstract of an AES paper presented at the Society's 41st convention, in 1971. The paper was read by an associate professor of Computer Science at the University of Utah.

In the intervening years, the professor continued his pursuit of superb audio fidelity, and eventually—as professors sometimes do—started up a little company of his own. By now, some 30 conventions later, the company and its founder have become quite well-known in the recording world.

Soundstream, Inc. has digitally recorded about 200 albums, and Dr. Thomas G. Stockham will become AES president next month, at the Society's 72nd convention. Apparently, what began as a part-time hobby has become a full-time pursuit.

Perhaps Stockham's most enduring (and endearing) trait is his use of the language. While others may prefer to spin webs of verbiage every time the mouth is open (which is often), the Stockham technique is one of instant access, no doubt a result of his computer background. Often, a Stockham response begins even before the inquiry has ended—especially at public gatherings when a question from the floor shows signs of turning into a doctoral dissertation. At a recent seminar on digital technology, Stockham delighted his audience by delivering more information in five minutes than some of his learned colleagues were able to expound in fifty.





*"I was never really satisfied with recording quality... The tape recorder was a particularly frustrating instrument."*

After watching the doctor in action, it occurred to your reporter that it was time to go off to Salt Lake City to learn a little more about the Soundstream operation, and of course, about Thomas G. Stockham.

### THE EARLY YEARS

Stockham's interest in audio began in high school, where he made the usual recordings of the school band. But even then he was vaguely dissatisfied with what he heard. "I was never really satisfied with the recording quality, and the tape recorder was a particularly frustrating instrument to me. It just didn't seem possible to capture all of the 'live' feed. Back in the early '50s, I knew this would all change. Tape recorders would improve vastly. But it didn't happen."

FM stereo was a disappointment, as Stockham perceived a back-sliding of broadcast audio quality. The rapid growth of television didn't help either. Thinking back, "In 1946, the big event in broadcasting was two consecutive Friday evening performances of 'La Traviata.'" Thinking not-so-far back, "What were the big events of the last ten years? They were certainly televised, with audio playing an almost-zero (maybe 5-10 percent) role."

Although recording technology didn't actually back-slide, it didn't move ahead fast enough either. Stockham looked (and listened) in vain for vast improvements. Although good stereo recordings were now being made, he was personally interested in other things—removing wow-and-flutter aberrations, cleaning up headroom, getting rid of hiss, low-frequencies anomalies and print-through.

In short, Stockham was searching for the recorder—the digital recorder—that did not yet exist. And, as his career in teaching and computer science developed, he found less and less time to pursue his frustrating hobby. But things have a way of changing.

### THE BOSE EXPERIMENT

"In the early '60s, I was doing some research at MIT, and discovered some things that made me think it would be possible to improve tape recording. I was working with Dr. Amar Bose. A few years earlier, he had started his speaker research as an EE project. At first, it was sort of a Saturday/Sunday hobby thing. He began investigating some basic acoustic issues which also interested me a lot (they had some big computing implications). The idea was: What does a room do to a sound?"

"At the time, the contention was that much of the dissatisfaction with loudspeaker performance was because you were 're-launching' the waveform in a second room. We wanted to find out just how significant that second room was. Bose hypothesized that the effect was considerable. And I hypothesized that we could simulate the notion of a perfect loudspeaker, even if we couldn't build one. Instead, we could 'probe' a room, and measure its acoustics. Then, with a digital

computer, we could simulate the effect that these acoustics would have on the original recording, without actually going through a real loudspeaker. In other words, we could 'degrade' the audio with the characteristics of the room only. Then, we could compare these recordings with recordings made in the room using a loudspeaker.

"Eventually, we could separately determine the effects of the room and of the loudspeaker, and get a feeling for where the problems were. To do all this, we made digital recordings of phonograph records and tapes, and then processed them with the room characteristics.

"The project got underway with 'home-brew' equipment—early 11- and 12-bit A/D and D/A converters, our own digital filters and amplifiers, and a computer memory. We connected the electronics to the converters, the converters to the computer, and we were in business.

"By 1962, we were digitizing audio. Our first "high-quality" recordings had a 25 kHz sampling frequency, a 10 kHz bandwidth, and were only minutes long. We weren't interested in ultra-high frequency response, although we did have the capability to sample at 37.5 kHz and did some experiments at this frequency. However, we kept the sampling frequency lower for the acoustic experiments, in order to keep the computing time down.

"We simulated the effect of putting a sound through a room over and over again. After five or six passes through the room characteristics (via computer), all sounds were alike. It sounded like pink noise, with a cacophony of ringing."

And so began Stockham's early digital work, in a search for new ways to process information. The computer was his ideal laboratory tool for testing new ideas, for moving forward in research, and best of all, for "playing" with audio recording. Soon enough, he realized that the way to make a recorder that would transcend the traditional limitations of the medium was to go digital. But at the time, there was just no practical way to get all those bits onto a piece of tape. It was possible, but the cost was astronomical. As Stockham puts it, "It took 15 more years until the astronomical absurdity had been reduced to merely being outrageously expensive."

"The early Caruso restorations of old 78s (released by RCA) was another test of our theories. We blended signals by convolution. Imagine a blurred photograph in which the 'signal' you want has been altered by a linear system whose characteristics are unknown. To get rid of the effect, you must do a Fourier analysis, and the Caruso project was a demonstration that this kind of thing will work." (For other demonstrations, see Robert Berkovitz's feature in this issue—Ed.)

In 1976, Stockham arranged the necessary financing, and started Soundstream. His first digital tape recorder was demonstrated to the Audio Engineering Society in late 1976,



*"At MIT, I discovered some things that made me think it would be possible to improve tape recording."*



and Richard Warnock presented a paper on "Longitudinal Digital Recording of Audio" (AES preprint 1169). A second-generation system was demonstrated to the AES the next year, and it attracted wide interest, but no customers. Coming from the academic/research world, Stockham wasn't prepared for the economics of the recording industry. And the recording industry wasn't prepared to gamble hard cash on Stockham's machinery. At the end of six months, the recorder was withdrawn from the market, and Soundstream was reoriented from recording sales to recording service.

### THE SOUNDSTREAM RECORDING SERVICE

For Stockham, "This worked out beautifully. We're personally responsible for more than one-quarter of the digital recordings that are now being made world-wide.

"Our present service is in three segments: recording, editing, and disc mastering. For recording and editing, we always provide an engineer. We don't insist any more, but none of our clients have done without our engineer, who is *not* the session engineer, though many of them have that capability. Generally, our clients prefer to keep that responsibility for themselves, so our man simply assures that everything is functioning properly."

As for getting ready for a digital session, Stockham advises, "Just pull out your (analog) recorder and substitute ours. Beyond that, be aware that the medium has a much-higher dynamic range, and much-lower distortion. Don't throw away these advantages by imposing the traditional operational functions of analog—gain riding, for example. And be sure your microphones have dynamic range and recording characteristics that are up-to-digital."

At a more subtle level, the Soundstream engineer may make some suggestions about microphone placement. Current practice is based somewhat on the limitations of analog tape, and these limitations are largely removed in digital recording. Stockham suggests miking for a direct-to-disc, or live-type of session, and capturing the sound of the performance. Later on, worry about the limitations of the disc. This could be a good hedge against future improvements in disc quality, which will allow the engineer to deliver greater dynamic range to the customer.

At first, Soundstream engineers quickly found that clients did not solicit advice on how to record their sessions. However, the "I can do it myself" attitude is gradually improving, as engineers and producers become more comfortable around this new breed of equipment.



Figure 1. The Soundstream digital tape recorder's electronics emphasize data reliability first, with a minimum of bells-and-whistles on the front panel.

With the Soundstream business now exclusively service-oriented, later-generation hardware has been tailored towards service, and away from sales. This means going heavy on systems reliability, and light on the bells-and-whistles (see FIGURE 1). "Our machine is designed and manufactured exclusively by us, our concept, our designs, our engineering, our maintenance. Our studies have shown that if we were to now offer a machine for sale, we would be forced to make a different set of engineering choices. For example, we'd have to work towards lower-cost, mass-producible circuits."

### RECORDING FORMAT

Soundstream offers a maximum of eight channels. Most of the digital work so far is classical, or at least is recorded in the classical manner. Of course, the top-40 market needs more channel capacity, but Soundstream is not yet in a position to provide it.

Looking ahead toward greater channel capacity, Stockham feels that it's not possible to put more channels on a piece of tape and still maintain the Soundstream level of data reliability. His machines have a three-level error detection-and-correction system built in. On the front panel, a series of LEDs (one per channel) indicate error concealment. If one single bit is wrong, one of these lights comes on, and *stays* on. "Maybe one light comes on in a week, generally due to a tape problem."

A second bank of lights indicate every incident of errors that are corrected, and a third set warns of the *possibility* of an error occurring.



*"We're personally responsible for more than one-quarter of the digital recordings that are now being made."*

### CRITICIZING DIGITAL AUDIO

Anyone who reads the Sunday supplement on Arts and Leisure has surely seen lots of dumb descriptions of what's wrong with digital recording. The favorite "explanation" by authors in search of authority is to say they miss all those little bits of beautiful music that get lost in-between samples. Such critics might be well-advised to stop trying to explain things they don't understand, and be content with "I don't like it—*period*." However, even if we ignore all the nonsense that gets into print, there is still a recurring "something-is-wrong" feeling out there.

Stockham doesn't lose much sleep over this. "In 1925, the critics didn't like electric recording. Later on, they didn't like the lp. Still later, they didn't like stereo." Apparently, if you believe everything you read, the art of recording has been steadily declining, ever since it was invented. Actually, part of the criticism is simply a resistance to something that's different. It's a new medium, and therefore not as familiar as the old.

"Maybe, the recording is *better*, and the customer doesn't like that." For any art form, getting closer to life is a risky business. Early photographers were not warmly received by viewers who had grown up seeing the world in a sketch or painting. Today,

we know better. If not, Stockham reminds us: "Like any other art, the imperfections of the recording medium are used, and become an almost-subliminal factor. When these limits are changed, people object."

### INSTANT-ACCESS EDITING SYSTEM

To this observer at least, ten minutes on a Soundstream editing session is more than enough to make a digital disciple out of any non-believer. What can it do? At risk of answering a question with a question, what would you like done?

The system is nothing more (or rather, nothing less) than a computer. Like any other computer, its boundary limits are pretty much a function of the programmer's imagination. (For more specific details, see Sherman Keene's feature article in this issue.)

Simply stated, the complete system consists of a transfer room, from which the eight (or less) channels of the master recording are loaded into the computer memory. With apologies in advance to Dr. Stockham for putting it this way, it's just like loading Pac-Man into your Atari (only more fun).



Figure 2. Dr. Stockham, with his PDP-1160 in the background, and an earlier prototype system up-front.

The computer (FIGURE 2), which lives in a nearby room, is a PDP-1160 from—where else?—Digital Equipment Corp. Its memory consists of two Century Data 300 Megabyte hard-disk drives, capable of holding 34 minutes of on-line stereo program. Of course, more drives could be added, but at 20 kilobucks



Figure 3. Senior editor Denis Mecham replaces the disk pack on one of the Century Data drive systems.

each, this will probably not happen until the prices come down. In practice, there's little or no need for additional drives, since each disk pack can easily be replaced while the other is being accessed (FIGURE 3).

In the editing room, the operator sits at a computer terminal with the usual keyboard and CRT (FIGURE 4). An adjacent scope displays waveforms and a digital tablet moves a cursor around the waveform for micro-surgery on those really tough editing sessions.



Figure 4. An editor's eye-view of Instant-Access digital editing.

As tapes are loaded into memory, they are named (as in, SAVE TAKE 3, or whatever). During editing, any program segment may be played back without waiting, simply by typing in the name of the segment and depressing the PLAY button. It certainly is instant-access editing, and the next segment can be on-line just as soon as you can type its name. If you're really in a hurry, ten segments can be assigned to single-stroke soft keys.

| EM13A   |      | Facility: 53, 52 |         | 10:23 10-JUN-82 Friday |          |                       |        |         |
|---|------|------------------|---------|------------------------|----------|-----------------------|--------|---------|
| HOLE3   | (RH) | (M)              | 15304;0 | 1000;0                 | 139      | 3040                  | 0      |         |
| A11P  | (L)  | (M)              | 16304;0 | 1500;0                 | 140      | 3040                  | 3116   |         |
| ASD   | (RL) | (M)              | 16304;0 | 2520;0                 | 139      | 3150                  | 3239   |         |
| ASE   | (RL) | (M)              | 21224;0 | 500;0                  | 139      | 3150                  | 3175   |         |
| AS1   | (RL) | (M)              | 21724;0 | 2120;0                 | 139      | 3200                  | 3280   |         |
| A15D  | (L)  | (M)              | 23652;0 | 500;0                  | 140      | 3200                  | 3205   |         |
| ASE   | (RL) | (M)              | 24352;0 | 2344;0                 | 139      | 3400                  | 3571   |         |
| A15E  | (L)  | (M)              | 27696;0 | 3000;0                 | 140      | 3400                  | 3553   |         |
| HOLE4   | (RH) | (M)              | 30696;0 | 1000;0                 | 140      | 3400                  | 0      |         |
| AS1   | (RL) | (M)              | 31696;0 | 1000;0                 | 139      | 3075                  | 3720   |         |
| A15F  | (L)  | (M)              | 32776;0 | 300;0                  | 140      | 3075                  | 3680   |         |
| AS1   | (RL) | (M)              | 33076;0 | 1632;0                 | 139      | 3720                  | 3003   |         |
| Next available location (M): 34708;0 (27792;0 (9:29,18016)) |      |                  |         |                        |          |                       |        |         |
| TPA)  |      |                  |         |                        |          |                       |        |         |
| SP:   | (M)  | 12900;0          | LG:     | (M)                    | 84,420   | SMV:                  | 0;1000 |         |
| USE:  | (M)  | 62500;0          | LI:     | (M)                    | 1935,675 | (8 Trks; Multi-track) |        |         |
| **12900;0 (1904;0)  |      |                  |         |                        |          |                       |        | 15804;0 |

Figure 5. The CRT screen, with a faceload of information that only a digital editor could love.

As the operator decides on suitable edit points, the short segues between outgoing and incoming takes are stored in a separate memory location. Aside from that, there is actually no edited music—not yet, anyway. So far, the only program is the one you've written into the computer. As usual, it's just a series of sequential instructions which the computer will dutifully obey, when and if you type RUN. Then, the computer plays your edited program. Except it isn't really edited at all. In fact, it doesn't even exist. What you are hearing is the computer instantly accessing the various program segments you've requested. If you like what you hear, you can save it on tape. If not, you can do some more editing. Best of all, having second thoughts about an edit in the middle of the program does not require re-doing everything that follows. Just change the necessary instruction, and it's done.

Like Tom Stockham, the Soundstream Instant-Access Editing System doesn't waste time yours or its. ■



# 'No noise, nor silence, but one equal music.'

John Donne, 1571-1631.

The new Klark-Teknik high-performance DN30/30 graphic equaliser offers much more than just a quiet ability to balance channels right across the audio spectrum. Thoughtful ergonomics are backed by a new circuit design breakthrough using ultra-stable microelectronic filter networks to set performance standards comparable with Klark-Teknik's 'golden oldie' the DN27A. The DN30/30 is the equaliser to boost a studio's reputation, meet broadcasting specs in less rackspace, cut costs and equipment failures on the road — because...

It fits two matched high specification graphic channels into a single unit, each providing 1/3 octave equalisation over a full 30 ISO centre frequencies.

It gives fine fingertip low-frequency control covering the subwoofer range down to 25Hz — with touch-sensed centre detents, selectable cut boost level range and fail-safe design giving extra certainty during live events.

Its advanced design, tough construction, stringent testing and long burn-in exceed even Klark-Teknik's previously high standards for reliability and consistent performance on the road.

For technical information ask for:  
Our DN60/RT60 Data Sheet.  
Our DN30/30 Data Sheet.  
Our Application Notes on equalisation.



**KLARK TEKNIK**  
*sound science*

**Klark-Teknik Electronics Inc.**  
262a Eastern Parkway, Farmingdale, NY 11735, USA.  
Telephone: (516) 249-3660

**Omnimedia Corporation Limited**  
9653 Côte de Liesse/Dorval, Quebec H9P 1A3, Canada.  
Telephone: (514) 636 9971

Manufactured by Klark-Teknik Research Limited, England.

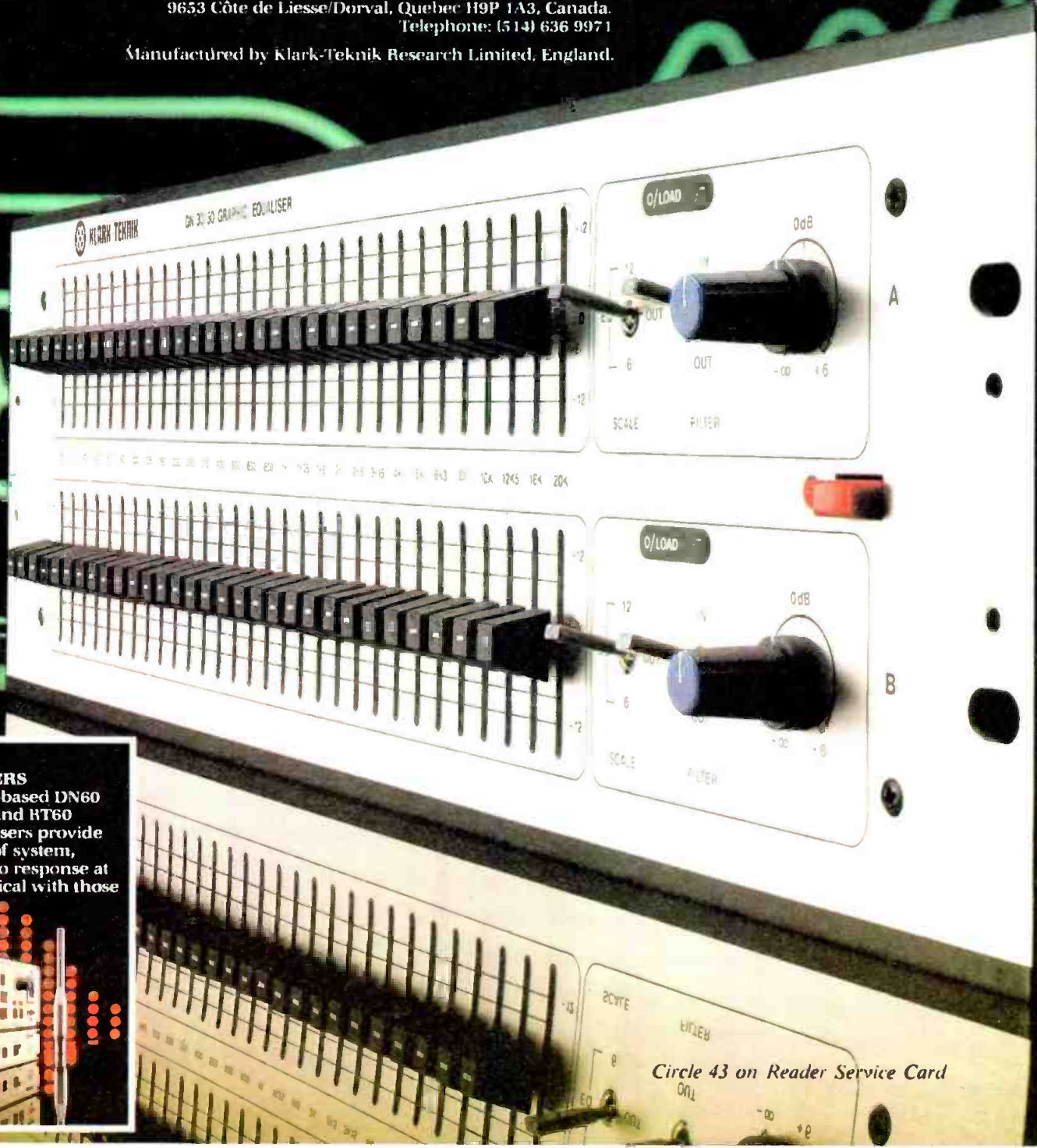

**SOME MORE EQUAL THAN OTHERS**  
The microprocessor-based DN60 Spectrum Analyser and RT60 Reverberation Analysers provide LED matrix display of system, performer and studio response at 30 frequencies identical with those of the DN30/30.

Circle 43 on Reader Service Card



# To Build the Impossible Dream: A Sound-Insulated Performance Studio Comes to the Big Apple

*An inside look at one of New York's newest concert halls.*

**W** I COULDN'T HAVE had a more hostile environment in which to create a live performance studio for WNCN. Yet by opening night, April 21, 1982, WNCN unveiled a finished product fit for the likes of Aaron Copland, Beverly Sills, Ruth Laredo and the host of other classical artists who took part in the four-hour concert which was broadcast live from the studio.

The studio had been promised to WNCN in 1976, when GAF Corporation purchased the station. It was to be fashioned from raw space located to the rear of WNCN's broadcasting facility at 1180 Avenue of the Americas in Manhattan. The space had been so-designated at the time of purchase. But until we got the go-ahead to build the performance studio, the space, occupying approximately 3,000 square feet on the building's fifth and sixth floors, had been primarily used for storage.

As we got started on our plans for the new studio, we were immediately faced with our first challenge. The studio would have to be built in two stages. Phase I of the project would entail creating a studio environment which would be conducive to live broadcast performances by small groups. Since the Phase I project was somewhat experimental, the budget would be much smaller than for Phase II—in which we would build a control room, as well as complete the performance space by floating the entire studio on a suspended floor, acoustically isolated from the rest of the building.

In undertaking the project, we had to draw plans for both phases, even though Phase II might be years away. We were charged with ensuring that plans for each phase would coordinate with the other, so that in building Phase II, the Phase I work would not be destroyed.

---

*Richard Koziol is Chief Engineer for WNCN. Alfred D'Alessio heads A. W. D'Alessio Associates of New York City, a systems and acoustic consulting firm for the television and sound recording media.*





### THE BIG PROBLEM: NOISE

Before even doing our preliminary measurements, we knew that our biggest problem in constructing the studio would be insulating it against noise, which came from two major sources.

The back of the building, which is where the studio would be located, faces an alley, and part of that alley faces a street. In addition to the street noise, which echoes in the alleyway, we also found noise dumped into the alley by the air conditioning systems of other tenants in the building.

A more threatening source of noise was located in the studio itself: a "wet" column which runs the length of the building. In this column are located steam pipes, drain pipes, and water pipes hooked into the building's lavatory flushometers, in addition to smaller, but still quite noisy, pipes. We had to find a way to insulate the noise from that column, or we'd never be able to broadcast from the studio.

Later on, we discovered there would be a third noise source.



Composer Aaron Copland with pianist Leo Smit.

# MAGNECORD MC-II

Compare Quality at this Price



*Incomparable  
from \$1100.00\**

- Meets or exceeds NAB standards, with IEC equalization on request.
- DC servo, flutter-filter drive runs true regardless of line voltage fluctuation.
- Cool operation; no ventilation required.
- Full remote capability.
- Long life heads and phase locked tape guides.
- Mono or stereo play models field convertible to record.
- Automation cue tones (stop, secondary, tertiary) with LED's and external switching contacts.
- Cue track access for FSK logging.
- Universal mic/line input.
- Immune to RFI and EMI.
- Rugged design in the Magnecord tradition —made in USA.

\*Suggested Pro Net Price

Quality Products for the Audio Professional

**TELEX MAGNECORD**

TELEX COMMUNICATIONS, INC.

9600 Aldrich Ave. So. • Dept. 1 • MN 55420 • U.S.A.  
Télex: Le Bonaparte • Dir. 711 • Centre-Atlas • Pa. 5 Nord • 93151 Le Blanc Mesnil • France

Circle 37 on Reader Service Card

About midway through construction of the studio, with all of our final measurements taken and planned for acoustically, the building management overhauled the air conditioning system throughout the entire building. Now it was running much better than before, but it also made more noise! We found we had to add more insulation.

### **ORIGINAL PLANS WENT AWRY**

We weren't far into our planning before we realized that we had another obstacle to contend with. The original designer of the space had apparently planned for a studio on the fifth floor, with the control room located on the sixth floor, overlooking the studio. But the only access between the two floors was through the building's elevator system! There were the obvious logistical problems with this arrangement, since without adding an expensive stairway, it would simply take too long to respond to situations which might arise.

In addition, a mechanical equipment room for the station is located on the sixth floor. This noise-producer is only surpassed by still another mechanical equipment room located above it, which serves the entire building.

It soon became clear that we would have to put the control room on the fifth floor, next to the studio, behind a windowed wall. While it caused a reduction in the studio's performance area, logistically it turned out to be a much better setup.

### **SOUGHT LIVE RECORDING ENVIRONMENT**

In planning the studio, we wanted to create a fairly-live recording environment as opposed to a controlled, multi-track recording studio. Performers, typically playing without a conductor in small ensembles or chamber groups, would have to be able to hear each other's instruments. The studio would be more like a mini concert hall, typically including a live audience. In recording performances, we would treat the studio environment just like the remote concert sites from which we do many broadcasts every year.

The reverberation time in a 30,000 cubic-foot multi-track studio (the size of the WNCN room) would run 250-300 milliseconds, but we figured that the ideal reverb time for WNCN's studio—intended for a coincident mike pair—should be one full second.

Before adding any acoustical treatment, we tested the space to find out exactly what we had. We found that the reverb time, which was fairly constant over the audio spectrum, was within 20 milliseconds of where we wanted it.

However, we did have a slap echo problem because of the studio's characteristic parallel surfaces. Our problem was to get rid of the slap echo without disturbing the reverb time—and without spending enormous sums of money to build splays and diffusers which would take up precious space in the studio.

### **ADDED ACOUSTICAL MATERIAL**

The solution was fairly simple: hang acoustical material at performance level, with the absorbers located at intervals across from reflective surfaces. This solved the studio's slap-echo problem without destroying the reverberation time. (We had no slap echo from floor to ceiling, thanks to an enormous stroke of luck. When the building had been constructed, fiberglass panels were placed on the ceiling.) And that's exactly what we'd have done to solve the problem, if there had been one!

### **BUILT ACOUSTICAL ENCLOSURE**

To tackle the problem of the wet column, we insulated each pipe, using a high-mass damping compound for the biggest noise producers. After we had treated each pipe, we designed an acoustic enclosure for the column. And (knock on wood!), it has been quiet ever since.

In order to insulate the studio from the alley noise, we were able to use high-mass dry-wall construction, building several feet in from the back of the building, and successfully eliminate the problem.

### **A WRENCH IN THE WORKS**

We thought we had covered the major sources of noise, and then we inadvertently found another one. In addition to the wet

column, the studio contained two structural columns, which had not concerned us as they produced no noise. But as construction proceeded, and the building's air conditioner was repaired, a nearby water return pipe from the cooling system caused the two structural columns to vibrate. We were forced to treat those columns as well.

### **MODIFIED AIR CONDITIONING SYSTEM**

Air conditioning was a concern to us for another reason. In its unfinished state, the studio area had not been included in WNCN's air conditioning system; now it would have to be added. But when we took estimates from vendors who could design a system for the studio, we found the costs were prohibitive, relative to the project's budget. We'd have to find another way.

It's no secret that a chief engineer at a radio station must, of necessity, wear many hats. And this one was no exception. Through experience, it was apparent that one position of WNCN's dual air conditioning system was not working to full capacity. That reserve capacity could be diverted and used for the studio.

A duct and louvre system was designed to tap into the existing air duct system. Because the studio's ducts are long, and turn several times, they tended to isolate noise generated by the air conditioning units, and this was not a concern.

Since the studio has a 22-foot ceiling, it acts as a reserve for this cool air, and the positioning of the ducts is such that as new air comes in, it naturally circulates throughout the room. The acid test of the system was during the opening Gala Concert, when we found the temperature remained constant over the four-hour duration—television lights notwithstanding.

Because we designed our own system, we were able to have a separate contractor come in just to do the ductwork. The cost to WNCN was substantially less than what would have been incurred had we had an air conditioning contractor design a new air conditioning system.

### **THE FINISHED PRODUCT**

In designing the finished size of the room, we again had luck on our side. We found that the resonant modes were well distributed across the audio spectrum, not hunched up at certain frequencies.

The studio, when finished, measured 1,150 square feet. Because of the center column in the room, we designated one quadrant of the room as the performing area, allowing for audience members in two additional quadrants. The performance area is located next to one of two accesses—which artists use as a private entrance. The fourth quadrant, obstructed by the columns, is used as an access area for the audience, and is located at the site of the second door.

The control room area—which was set up as a remote recording area during Phase I of the project—is located directly across the room from the performance area, affording a clear view of the entire room through a large double-glazed window.

The doors themselves are steel-clad and sound-retardant, with expansion seals in the jambs.

### **WNCN ACTED AS CONTRACTOR**

Despite the usual and unusual problems encountered in building the studio, the finished product was a resounding success. Total construction time was about nine months, due in part to the fact that the chief engineer—with many duties acted as project manager with the station while serving as general contractor for the project. Fitzgerald Construction did much of the major construction work and Jorge Cao was interior designer for the project.

At its opening, hundreds of musicians, music-lovers and members of the press attended the open house and Gala Concert which featured more than two dozen classical artists in a four-hour program. WNCN General Manager Matt Biberfeld proclaimed the studio "a new concert hall for New York City." In his column in *New York* magazine, critic Peter Davis referred to it as "a stunning new live-performance studio." ■



# Techniques for Hum and Noise Reduction

## INTRODUCTION

**T**HE purpose of this application note is to provide the reader with a basic understanding of commonly encountered causes for, and cures of, hum and noise in professional sound systems. Included will be a discussion of signal sources and their peculiar characteristics, noise sources, mechanisms of noise energy transmittal, ground loops, power distribution, and good cabling practices.

Sometimes the pursuit of hum-and-noise reduction appears to be a mixture of witch-hunting and mystical rites to the electron gods. But keep the faith and try to develop a firm conviction that for every observable phenomenon there is a rational scientific explanation.

## SIGNAL SOURCES

Before describing the peculiarities of specific sound sources, a discussion of the two primary categories of sources and their associated interconnections is in order.

FIGURE 1 shows both balanced low-impedance and unbalanced high impedance systems. Their power-transfer capability is roughly equivalent; the former being low voltage high current, while the latter is high voltage low current. Another obvious similarity is the use of an outer shield conductor. So much for similarities.

## THE UNBALANCED LINE

If the outer shield is a perfect conductor and also achieves 100 percent electrical shielding, then the laws of physics decree that an external electrostatic field will not produce any net charge (or voltage) on the inner conductor with respect to the outer conductor, since it is completely surrounded by an equipotential surface. However, nature is never very generous, and has failed to provide us with a perfect conductor, and a 100-percent electrical shield is difficult to attain while retaining flexibility and low cost. The shield helps considerably, but there is always

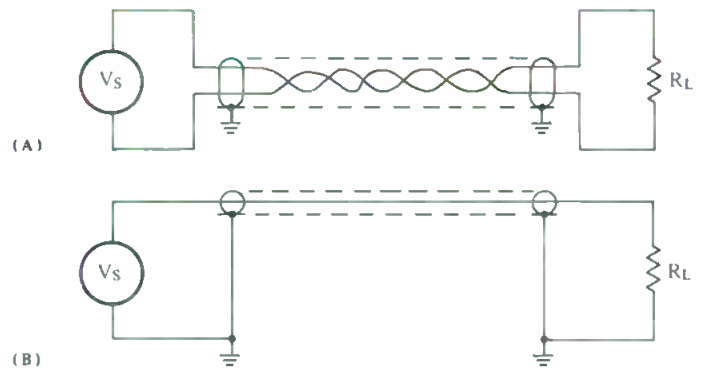

Figure 1. Balanced (A) and unbalanced (B) lines.

**Get Aligned  
Stay Aligned  
with STL precision  
magnetic test tapes**

These dependable tapes are used by broadcasters, recording studios, equipment manufacturers, governments and educators throughout the world. Widest variety...Alignment, Sweep, Pink Noise, Level Set, Azimuth and Flutter/Speed. Available on reels, in cartridges and in cassettes. Also, the Standard Tape Manual & the Magnetic Tape Reproducer Calibrator.

*Phone for fast delivery or free catalog.*



**STANDARD TAPE LABORATORY, INC.**

26120 EDEN LANDING ROAD #5 HAYWARD CALIFORNIA 94545 • (415) 786-3546

some net charge that leaks through, and therefore room for improvement exists.

### THE BALANCED LINE

Enter the twisted pair. Since we are concerned with imperfect shields, let's examine the limiting case—that of no shield at all (refer to FIGURE 2 for the following discussion). Assume that we wish to transmit an instantaneous signal voltage of 2 volts. For the unbalanced system, this 2-volt signal is applied to the center conductor. In the balanced scheme, the signal is divided into equal-and-opposite 1-volt signals. These voltages are typically generated by a center-tapped transformer with the tap grounded, thereby creating a sort of electronic teeter-totter. At the receiving end, it is the difference in voltage on the pair of wires which is interpreted as the signal, rather than the absolute value of the voltages.

So what does all this do for us? Again referring to FIGURE 2, let us further assume that an external electrostatic field is present and that it affects all three wires by inducing an additional 2 volts. It is not important here to understand the field theory which makes this happen or even to know what kind of field it is (call it a watermelon field if you wish). What is important is that from experience we know that these fields do exist and intuition tells us that they do induce unwanted voltages on signal lines, since their audible replicas eventually reach our ears. For the unbalanced line this induced voltage is added to the original 2-volt signal for a total of 4 volts at the receiving end of the line, obviously a gross distortion. In the case of balanced transmission, our original signal levels of +1 volt and -1 volt have been altered to +3 volts and +1 volt by the effects of the external field. However, the difference is still 2 volts and so our original signal has survived unscathed. The balanced method therefore derives its tremendous advantage from the differential operation of the receiving circuitry. This property is known as common-mode rejection, since voltages common to both wires are rejected as much as possible. When the twisted pair is shielded there is an additional improvement which yields a "belt and suspenders" solution to hum and noise reduction.

Another advantage of balanced low-impedance is that very long cable runs can be made with no appreciable loss of high-frequency content. The center conductor(s) are in close physical proximity to the shield and therefore create a stray capacitor to ground, albeit a very small one. However, the value of this capacitance is directly proportional to cable length (in fact cable manufacturers specify it in picofarads per foot) and can therefore become significant for long cable lengths. FIGURE 3 shows the resulting equivalent circuit which, due to the source resistance, is a classic low-pass filter whose cut-off frequency is given by:

$$f_c = 1 / (R_{SOURCE} C_{STRAY})$$

One can deduce from this equation that, for a given cable-length (or  $C_{STRAY}$ ), a lower source impedance will produce a higher cut-off frequency. Conversely, for a given cut-off frequency, a lower source impedance allows a larger  $C_{STRAY}$  and therefore longer cable lengths.

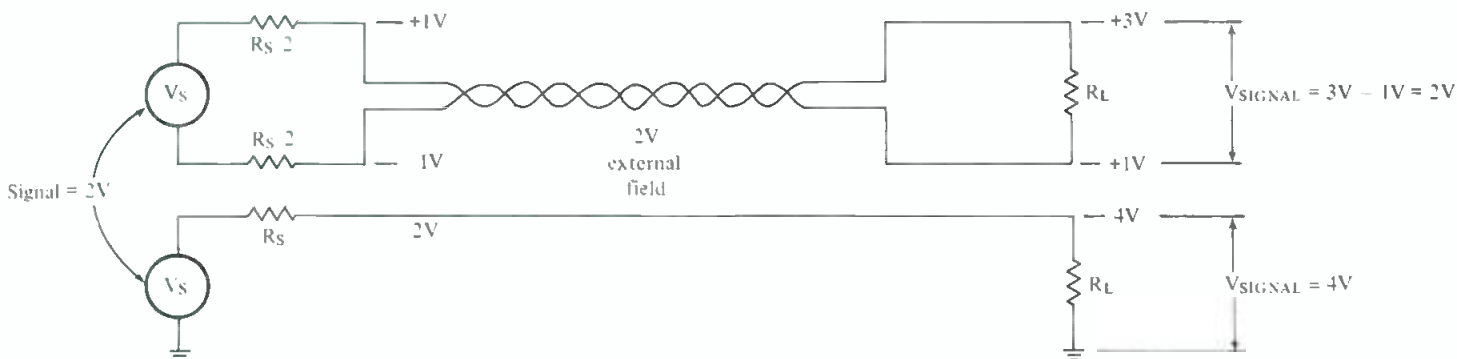

Figure 2. The balanced line offers superior common-mode rejection.

Having developed a firm grasp on the operating characteristics of signal sources and transmission methods in general, we will now discuss the peculiarities of specific signal sources.

### ELECTRIC GUITARS AND AMPLIFIERS

The first step in solving hum and noise problems with electric guitars is to logically isolate the source of the problem. There are basically three possibilities: the guitar, the interconnecting cord, and the amplifier. The cord should be checked first since it is the easiest to isolate and repair.

Next determine whether the guitar or amplifier is at fault by simple swapping tactics. If the guitar is at fault it may be due to one of several causes. Pickups may be the source, particularly in older guitars. Most pickups are of the variable-reluctance type which operate on the principle that the strings present a variable magnetic path length (or reluctance) to the pickup, which is excited by a permanent magnetic field, thereby generating a voltage on the integral coil. By being inherently responsive to magnetic-field variations, these devices are obviously affected to some degree by external fields. Modern variable-reluctance pickups incorporate hum-bucking coils which tend to minimize external field sensitivity. Unfortunately, the cure for the pickup problem is sometimes the purchase and installation of a modern pickup. Local music dealers can generally be of assistance in locating a source for the pickup as well as installing it.

Inadequate shielding of the compartment housing the tone and pickup controls can also be a culprit. Aluminum foil tape can be used to shield the compartment and should be grounded to the output jack. A foil shield under the pickup(s) is also frequently employed, so check its connections.

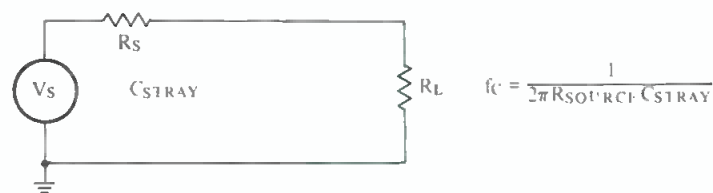

Figure 3. The effect of cable capacitance on frequency response.

As with guitars, age is often a problem with amplifiers, most notably the vacuum tube designs. One inherent problem with tube equipment in general is the AC voltage on the filament which can couple to the signal electrodes as hum. There is no cure for this problem short of installing a DC supply for the filaments, and this is not a simple fix. Another problem that occurs in older amps is excessive ripple on the power supply lines, which also manifests itself as hum. This problem is often due to dehydration of the electrolyte in the filter capacitors and can usually be identified by a visual examination of the capacitors (they're always big and usually in metal cans) where



the leads exit the case. Any seepage or corrosion-like solid deposits indicate a problem which should be corrected by replacement.

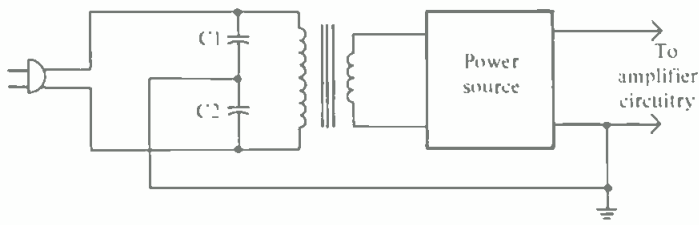

Figure 4. A commonly-used power input circuit.

A power supply input circuit which was virtually universal during the two-prong power plug era is shown in FIGURE 4. This circuit has been the cause of more than its share of problems despite its relatively innocent appearance. The original intent of the designers apparently was to by-pass noise on either line to circuit ground. A noble cause, but there are no guarantees that circuit ground is earth ground (in fact it is very likely not), which is where the noise should be by-passed to begin with. Furthermore, when the ground is floating, C1 and C2 comprise a capacitive voltage divider placing circuit ground at a 50-60 volt AC potential. This has caused the fingers of more than a few guitar players to tingle when some part of their anatomy is simultaneously in intimate physical contact with a grounded mic stand. The capacitors are generally small enough in value that the current they supply is not lethal, but someone who wishes to perform in a tub full of water may have a serious problem. Finally, with respect to noise performance, the circuit is also highly undesirable since the capacitors guarantee that any noise on either line will be dumped into circuit ground, which is the last place you want it to go. So the recommended fix is to remove the damned capacitors, throw them on the ground, and stomp on them to display your disgust.

## MICROPHONES

Dynamic microphones are typically balanced low-impedance sources, and when handled with a reasonable amount of care are highly reliable devices which generally do not exhibit hum or noise problems. If a problem does occur, a cable or connector should immediately be suspected and can be readily isolated simply by swapping the suspect component with a known good one.

Condenser microphones are sometimes utilized due to their extremely-wide frequency response. While these are inherently high-impedance devices, they typically employ built-in preamplifiers and/or matching transformers such that their electrical output characteristics are identical to the dynamic type, with all the attendant advantages.

## ACOUSTIC GUITARS AND PREAMPS

Acoustic guitar pickups are generally less troublesome than electric pickups since they usually transduce the guitar body movement into an electrical signal rather than including the strings in a magnetic circuit. Cable problems are, as always, fairly common particularly since the connector is usually a miniature phone type. It is wise to avoid the molded cables and make your own, using high-quality wire and metal-shell connectors. This is well worth the extra effort since it will enable

you to repair a cable when it does fail (which is inevitable in road use)—unlike the molded types which should simply be discarded.

Since the acoustic pickup has a very-low-voltage, high-impedance output, a preamp is generally employed to amplify and buffer the signal. Often a direct box will be placed after the preamp to make the source appear electrically equivalent to a balanced low-impedance source such as a microphone. In fact, the so-called "direct box" is really nothing more than a transformer having primary and secondary impedances in the vicinity of 10,000 and 500 ohms respectively. By utilizing a direct box in this application one can enjoy the benefits of balanced low impedance transmission along with the electrical isolation of the guitar and preamp from the mixing console. Two potential problems arise at this point however. First, most preamps use garden-variety operational amplifiers such as the LM358 (National) and the MC1458 (Motorola) in the signal-processing stages. While these devices perform admirably in many circuits, they are less than ideal for audio preamps due to significant amounts of crossover distortion and relatively poor input noise specifications. This can often be cured by replacing the op-amps with better devices such as National's LF442 (a BIFET device with ultra-low current drain) or Signetics' NE5512. The second problem is that some of the newer preamps have a built-in direct output which consists of a solid-state circuit instead of a transformer. The reason manufacturers do this is to reduce cost, despite the claim that they did it to reduce distortion (which it probably does). This feature comes at the expense of transformer isolation which can result in ground loops and/or increased levels of hum. More about direct boxes as well as ground loops later.

## KEYBOARDS

With a few exceptions, keyboards are largely electronic in nature, and typically do not present any new problems. Some of the previously mentioned problems do occur however. For example, a home-brew conversion of an acoustic piano to an electric environment will often be performed by installing pickups and preamp(s) similar, or even identical, to those used in acoustic guitars.

Clavinetts are also prone to noise problems, particularly older ones. These problems are similar to the electric guitar difficulties, since the principle of operation is the same. The problem is compounded due to the built-in preamp employed. Often much of the problem is due to inadequate shielding and lack of grounding of electrically unused metal parts, such as the front panel and switch brackets. As with electric guitars, shielding the preamp control compartment with grounded foil tape and grounding all metal surfaces will go far in reducing noise.

Synthesizers and other purely electronic instruments are generally clean signal sources. Noise that does occur is due to equipment design shortcomings and as such is beyond the scope of this discussion. However, hum problems may occur with any of the keyboards (as well as just about any instrument) due to ground loops. Ground loop phenomena will be discussed later in a separate section.

## DIRECT BOXES

As was previously mentioned, the direct box is a device which converts from unbalanced high-impedance to balanced low-impedance transmission. A schematic for a full-feature direct box is shown in FIGURE 5, with the main ingredient being the transformer. The purpose of the high-impedance in and out jacks is to allow the signal to be run to an on-stage amplifier for monitor purposes as well as to the mixer. The pick-up, amp switch simply changes the gain much like pad switches on a mixer so that a high-level signal from an amplifier, as well as a

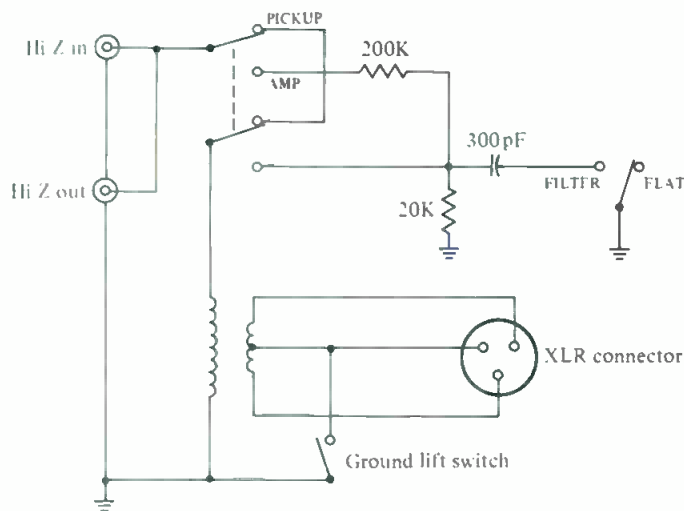

Figure 5. A full-feature direct box.

low-level signal from a pickup or preamp, may be accommodated with equal ease. A filter switch is provided so that the signal may be run essentially flat. Otherwise, the treble may be rolled off. This feature is useful for electric guitars, especially at distortion settings. This is due to the fact that guitar amps usually employ speakers in the 12-inch diameter range, which have relatively poor high-frequency response, while the electronic signal from the amp is generally full-range. This causes the signal to the mixer and ultimately the main speakers to sound much more "raunchy" than what the guitarist hears on stage. The remaining feature is the ground-lift switch which allows complete isolation of the input and output circuits. The best position for this switch is simply that which yields the lowest hum and or noise. This can be determined experimentally.

For those so inclined, construction of a direct box is a relatively straightforward matter which can save considerable cost if many channels are required. The most expensive item is the transformer, such as a Triad T-1X, which will run about \$10-15. Total cost should be under \$30. Another approach the author has found useful is to actually build the direct box into electric guitar amplifiers. Room can usually be found on the rear panel for the mic connector and on the inside for mounting the transformer. This technique is not recommended for the novice and care should be taken to use proper wiring practices. Mount the matching transformer as far away as possible from the power and output transformers. It is also highly desirable to pick off the signal prior to the volume control so that changes by the performer will not alter the volume in the mains. Finally, some experimentation with the capacitor value is suggested so that the tone of the mains is roughly equivalent to that of the amplifier (the values shown are typical but at least represent a starting point). The advantages of building the direct box into the amplifier are as follows:

- Elimination of the phone connectors and the associated patch cord.
- Reduction of on-stage clutter due to more boxes and cords underfoot.
- Less possibility of switch settings being inadvertently altered.
- Ability to "tune" each box to match the amp for truer frequency response characteristics.
- The advantages of balanced low-impedance transmission with the ease of simply inserting a mic cable.

## NOISE SOURCES

Noise sources can be classified into three different types. The first type represents sources whose noise energy is transmitted via the power line and include the following:

- Lighting and other natural atmospheric electrical disturbances.
- Switching of inductive loads (motors, transformers, etc.).
- Motor brush noise (cash registers and small appliances).
- Lighting equipment, especially dimmers.

The second type of noise source is characterized by primary transmission through air such as:

- Radio transmissions of various frequencies, e.g. AM, FM, CB, and TV.
- Microwave sources (ovens, radar, etc.).
- Computers and other digital devices.

The final category of noise is that which is generated internally by electronic equipment used in the sound system itself. This type of noise is generated both by semiconductors (diodes, transistors, and integrated circuits) and by passive devices (resistors, capacitors, etc.). The primary causes are the following:

- Thermal noise.
- Shot noise.
- 1/F noise (also referred to as flicker noise).

The first two types of noise are relatively common to everyday experience, manifesting themselves in TV reception or stereo operation. For example, we have all been watching our favorite episode of Star Trek for the 17th time when someone in the kitchen fires up the electric mixer, producing picture tearing and an obnoxious whine in the audio. Ditto for hair dryers and vacuum cleaners. A heavy inductive load such as an air conditioner motor will often produce a momentary shrink or a bright flash in a TV picture. Light dimmers will sometimes produce a buzz in a stereo system.

With this brief and informal introduction to noise sources, let us now deal with the question of how the unwanted signals are transferred to the sound system and, more importantly, what the devil to do about it.

## NOISE ENERGY TRANSMITTAL

As we mentioned previously, noise sources may be categorized by the manner in which their energy is transferred to the sound system. The primary mechanisms are, of course, air-borne and line-borne. However, life is never simple, and in practical situations noise usually enters the system by a combination of the primary mechanisms. For example, noise from a light dimmer may travel through the power line and into an electric guitar amplifier's power supply, thereby disturbing sensitive signal stages. However, an alternate path also exists since the building's power lines act like a large grid-like antenna which radiates a portion of the noise energy. This airborne energy enters the system through the guitar pickup or the sensitive front-end stages of the amplifier. Of course, there's other airborne noise, such as a truck driver on the interstate with a 1000-watt linear amplifier strapped to his \$17 CB (over-modulated of course) thereby splattering electronic replicas of unintelligible babble for miles in all directions. Talk about air pollution! Again, the power lines act as an antenna, only this time they are receiving rather than transmitting. The noise travels down the line and into the amplifier as before. Even more complicated interactions can arise, particularly in the case of radio-frequency interference (RFI). Let us re-examine the CB case, where we had air-borne, then line-borne interference. Once the noise enters the metal case surrounding the amplifier (which acts as a shield) via the line cord, it is possible (in fact not uncommon) for the noise to be re-radiated and again be amplified by sensitive circuits.

By now many readers are undoubtedly developing a feeling of despair, since noise clearly obeys Murphy's Law. Those of you who are still awake, however, may have deduced that, with the exception of cases where air-borne noise energy enters a pickup



or amplifier directly, there is a common denominator in all this mess. That common denominator is the power lines.

## CLEAN UP YOUR ACT

Since we have identified a common culprit in noise problems, it would be logical to address this unhappy condition. The first step is to apply filtering to the power lines. This should be done with a high quality RFI filter of the type used in computers and instrumentation. Do not use the cheap TV varieties from your local radio shop for two reasons: 1) they can't handle the current and 2) they seldom, if ever, work.

Line voltage transients due to lightning have been previously mentioned as noise sources. What was left unsaid however, is that these transients can reach potentials which are extremely damaging to electronic equipment. During thunderstorms, the 120-volt outlet frequently exceeds 1000 V and levels higher than 5000 volts will occasionally occur. Fortunately the duration of these transients is typically very short (on the order of 10 microseconds) but still long enough to destroy our rather unforgiving semiconductor devices. Equipment can be protected against transients of this nature by devices known as "logically enough" transient suppressors. One particularly effective transient suppressor is the metal-oxide varistor (MOV) which behaves like a voltage-dependent resistor (hence the term varistor). Below a certain voltage, known as the threshold, the device conducts only a few milliamperes, but above the threshold conducts very heavily. In this manner the MOV tends to clamp the line at reasonable voltage levels. Circuit placement of the device is between line and neutral.

It is also good practice to physically separate lighting power wiring and audio cabling as much as is practical. This is due to the fact that light controllers employ phase control circuits and typically generate a considerable amount of power line noise, usually manifested as the infamous sound system buzz.

## GROUND LOOPS

The term ground loop is probably the most often quoted yet least understood of all the terms in the professional audio vernacular. Let us first describe the mechanism of the ground loop and then explore its significance with respect to sound systems.

Ideally, a ground is a ground is a ground. Unfortunately, in the real world this is not the case. The ground loop phenomenon arises because conductors and connectors have finite resistance and will therefore exhibit a voltage drop when current flows through them. We therefore have a situation in which the ground terminal at the stage power outlet is different from that at the mixer, giving rise to hum and possibly noise problems. The astute reader will at this point probably say "wait a minute, grounds are not supposed to be current-carrying conductors since they are only there for safety." A valid objection. However, one must consider what happens back at the fuse box. Referring to FIGURE 6, we see that the neutral and ground connections both go to the center tap of the transformer and to earth ground through the grounding stake (sometimes a water main is used). Also shown are some parasitic wiring resistances which cause differences in ground potentials. For example, let us assume that  $R_1 = 0.1$  ohm (normally considered by electronic types to be negligible) and that Branch 2 has a load current of 10 amperes. According to Ohms Law ( $E = IR$ ) a voltage of 1 volt will therefore appear across  $R_1$ . This 1-volt drop will not noticeably affect the brightness of a light bulb, but could be catastrophic to the sound professional! Worse yet, if the stage is on Branch 1 and the mixer on Branch 2, then the ground(s) between the stage and the mixer will be in series with  $R_1$  and actually share some of its current. Now you can see why it is referred to as a loop.

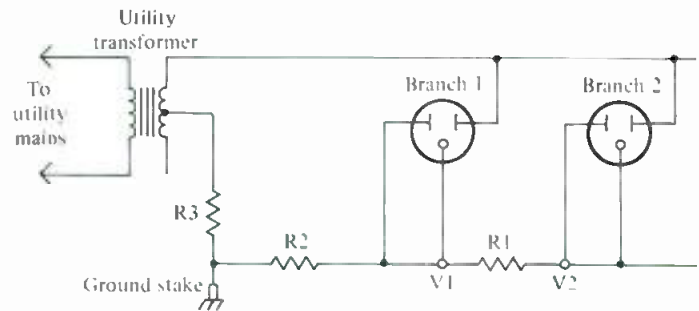

Figure 6. The ground-loop phenomenon.

Now what to do about it. You obviously don't have time to rewire every building in which you are going to set up for a three-day gig. One must therefore somehow break the loop. There are two basic solutions. One is to float everything at one end of the system or the other. This is probably the most commonly employed approach. However, there is one important aspect to be considered and that is safety. Let us examine the purpose of the ground conductor in the first place. Assume you are standing knee deep in water in a basement and you are going to drill a hole in something. Let us further assume that your drill has developed an internal short such that the metal case is placed at or near line potential. Now if you "float" your drill by using a three-prong-to-two-prong adapter (cheater) the case of the drill will be at line potential and therefore your body will present a path to ground, and you'll soon wind up under the ground. However, if the outlet is properly wired and no cheater is used then the same faulty drill will present essentially a short-circuit from line through the case back to ground, thereby drawing large amounts of current and blowing the fuse or throwing a breaker for the circuit, safely removing the lethal condition.

At this point, one could argue that even if the mixer end were floated, the signal conductor's grounds still constitute a safety ground. However, these wires normally carry only milliamps and are therefore relatively smaller wires. Therefore if a fault develops (which can momentarily exceed 100 amps), the small ground wires could fuse before the fuse does! To counteract this problem you should run a separate safety ground of very heavy-gauge wire (about #12) and make sure it is tied to ground at an outlet at one end and to all the chassis at the other.

The other approach to breaking the loop is to use direct boxes on every signal source which is line-powered. This is very effective and allows equipment at both ends to be grounded normally. To keep costs down you can easily construct your own.

## SUMMARY

We have covered a lot of territory so let's step back and review the basics:

1. Clean up the line. The significance of this should be obvious if you've managed to read this far.
2. The importance of good cables cannot be overemphasized. For best results, make your own with high-quality wire and metal-shell connectors being sure to use good soldering practice (good solder too—60/40 resin-core only).
3. Isolate problems by simple swapping techniques. Swap one component at a time so that you're confident you've isolated the problem. If you become confused, swap things back until you are sure of your observations.
4. Use direct boxes whenever possible and eliminate ground loops at all costs.
5. Correct faulty or inadequate shielding in instruments employing magnetic pick-ups.
6. Upgrade equipment when necessary, such as ancient pickups and tube amps.

One last word of wisdom—Don't succumb to superstition. I will repeat a statement from the introduction. For every observable phenomenon there is a rational scientific explanation! ■

# The FFT: Big-Time Mathematics Comes to Audio

## *Part Two: Making audio measurements with the FFT.*

**T**HE FAST FOURIER TRANSFORM (FFT) is a particularly efficient way to calculate the spectrum of a digital signal by the discrete Fourier transform method. Part I of this article dealt with the underlying principles in a simplified way; now we take up practical applications.

A discrete Fourier transform is executed by repeatedly multiplying the numerical values of a digitized signal by values of sines and cosines. The FFT achieves its efficiency—typically hundreds of times faster than a direct Fourier transform—by setting an important special condition. If the computed spectrum consists of a set of multiples (harmonics) of a single frequency, many of the multiplication operations required will be identical. In an FFT, each such operation is done only once, and the result is saved and moved about in the computer's memory as needed. The FFT is important in many fields of research and engineering because it provides answers that are not readily available in any other way. Although it has limitations, like all measurement methods, the FFT has come to dominate the world of digital signal processing because it allows

users to look into a rich new world of signal characteristics, especially where transient signals are concerned.

In this second and final part of the article, we will look at some practical measurements made with an FFT system, and see how its special properties influence the way in which results appear. Although use of the FFT as an analysis tool is still largely restricted to laboratory computer systems, a new system<sup>1</sup> allows any owner of an Apple II computer to install an FFT analysis system that can carry out most digital signal processing functions of interest in audio, medical and other fields. All of the measurements and plots shown here have been made with an Apple II with this system installed. At the end of the article, there is an FFT program in BASIC and readers who are interested will find it easy to learn more about the FFT simply by running the program with different data inputs. The program is usable with very little change on any computer running BASIC. For Apple II owners, a simple graphic display sub-routine is included.



Figure 1. Producing an impulse. (A) a single low frequency, (B) the summation of four frequencies, and (C) the response after the summation of 16 frequencies.



## THE TIME DOMAIN AND THE FREQUENCY DOMAIN

Audio measurement is ordinarily carried out by comparing the output of the tested device to the characteristics of the input signal. For example, analog measurements of frequency response are made by driving the tested unit with a signal that changes frequency uniformly while maintaining a uniform level. By tracing the level of the output on chart paper synchronized to the frequency of the input signal, a plot is obtained showing the variation in output with frequency.

In making such a conventional measurement, we send frequency-domain information to the tested unit, and we get frequency-domain information directly from the output. When the FFT is used to obtain data corresponding to the frequency response, the input signal is in the time domain, and so is the output. The function of the FFT is to convert the data from the time domain to the frequency domain.

What are we talking about? In analog frequency response measurements, the test signal does not change with time, for all practical purposes. The frequency must change slowly enough so that the plotted result will be the same as if individual sine waves that were the same forever were sent through the tested device. With the FFT, as we will see, the important property of the test signal is not its stability in time, but precisely the way it changes with time. Later, we can review some of the interesting peculiarities of the FFT's mathematics. First, let's look more closely at the kind of test signal usually used with the FFT. We'll take a loudspeaker as the device to be tested.

### THE TEST IMPULSE

A widely-used test signal for FFT measurement of audio equipment is an impulse of extremely small duration, often synthesized by the same computer that carries out the FFT, and lasting less than one sampling interval. For full audio-range testing, where the sampling rate would be on the order of 50 kHz, for example, the impulse would have a duration of less

than 20 microseconds. Looking at such an impulse, it sometimes seems intuitively difficult to believe that it has the low frequency content needed to make a useful test signal. However, the impulse contains all frequencies from d.c. to half the sampling rate in equal measure. The falloff, in any case, is an inconsequential reduction in high frequency content; the reason will become clear in a moment.

One way to show that an impulse is indeed the sum of every frequency that can be represented at a particular sampling rate is to let a computer generate and sum waves of these frequencies. Naturally, nobody would want to wait around forever to prove the point, but it takes only a few minutes and a simple program to see that the proposition is valid.

To get an impulse, the waves of identical amplitude and gradually increasing frequency need to be summed with their highest levels coincident, that is, "in phase" at one central point where  $t = 0$ . FIGURE 1A shows the first wave, which is not d.c., but can be imagined to be some very low frequency. Letting the computer run for a few seconds, and stopping the program after three more waves have been added, we get the picture in FIGURE 1B. It is clear that the added waves have done some cancellation at the sides of the plot, but they can do nothing but add at the center, where every wave is going to have a value of 1.0. Allowing sixteen waves to be summed produces FIGURE 1C, after which there can be little question of how things are going to go. If the program runs until several hundred waves have been added, the central peak becomes a rather thin spike, and the wavelets at the sides flatten out to give a quite credible impulse, *quod erat demonstrandum*.<sup>2</sup>

Another way to evaluate the frequency characteristics of the impulse is (of course) to transform it from the time domain to the frequency domain using the FFT. If we carry out an FFT operation on the impulse shown in FIGURE 2A, we obtain the magnitude plot shown in FIGURE 2B, which is absolutely flat over the entire range.

To go a little further, we can look at the group delay, which the computer gives us a few moments later if we ask it to do so, shown in FIGURE 2C. Group delay is defined as the rate of change of phase shift as a function of frequency. Phase shift is more directly computed by the FFT, but group delay corresponds more closely to the intuitive idea of time delay.

The group delay is 0.1 millisecond at all of the frequencies shown. If we look closely at FIGURE 2A, we can see that the impulse is in fact 0.1 millisecond from the start of the time scale at the left side of the display, accounting for the delay shown. The important point is that there is no delay of any frequency relative to all the rest, as predicted. No surprise there.

In the first part of the article, in reviewing the procedure for calculating a Fourier transform, we multiplied the test waveform by successive values of a sine and cosine wave of each frequency, sampled at the same rate as our test waveform. If we now consider what result this would give with the impulse, the answer is (almost) obvious. Every cosine wave will start with a value of 1, regardless of its frequency, so the first product will be  $1 \times 1 = 1$ . After that, we will get nothing but zeroes as products, because the impulse lasts for only one sample period. For sine waves, which start with a value of zero, we will get only zero as a result, in the first sample position and everywhere else. That means that every frequency that can be represented at this sampling rate will have the same magnitude: 1.

### A LOUDSPEAKER UNDER TEST

Let's look at an impulse that has passed through a loudspeaker (FIGURE 3A). The impulse, generated on the IQS circuit board, has actually passed through a power amplifier, loudspeaker, microphone and analog-to-digital converter. The loudspeaker used was a small, metal-cased extension speaker with only the woofer working. The impulse was sent to the loudspeaker sixteen times at precise intervals. Each time, the computer waited for the sound to travel across the room to the microphone before starting to take in and digitize about 23 milliseconds of data (2048 samples). Because the timing can be controlled to within a millionth of a second without difficulty,

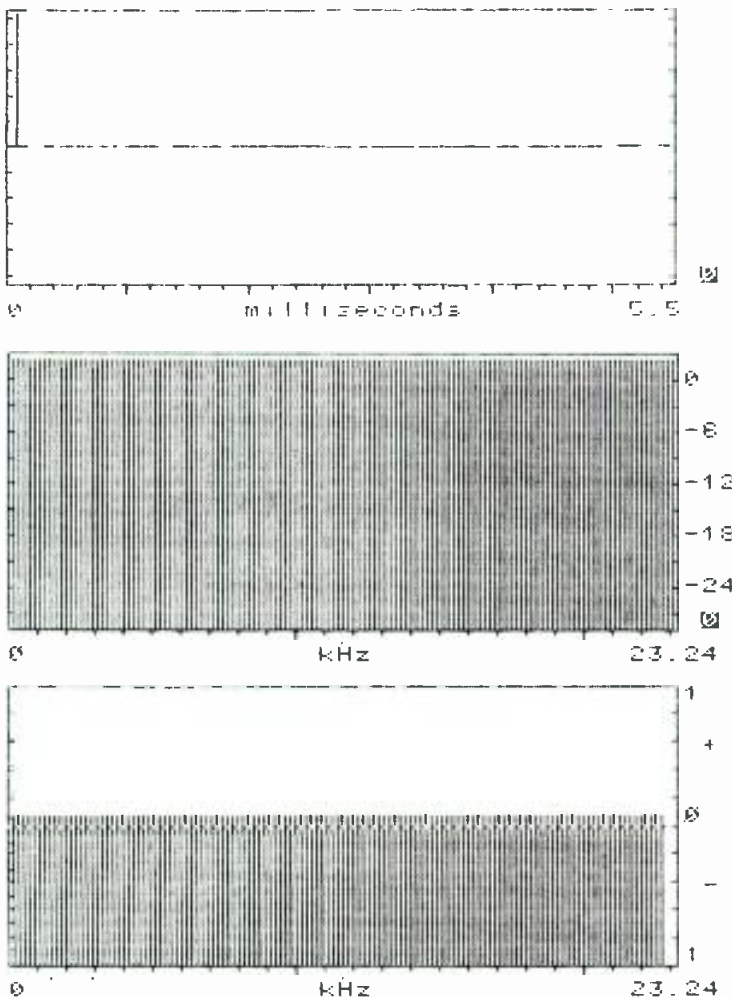

Figure 2. A single impulse (A) produces an absolutely flat magnitude response (B) and a flat group delay response (C) as well.

the successive impulse responses can be added and averaged synchronously by the computer. This procedure reduces the amount of interface from traffic noise and other environmental disturbances, and is one reason that the FFT method can be used in relatively noisy environments. Averaging sixteen impulses gives an effective reduction of 12 dB in ambient noise; averaging 128 impulses, as many as the IQS program allows, gives an effective improvement of 21 dB in the signal-to-noise ratio.

Astute readers will have noticed that I have not referred to FIGURE 1A as "the impulse response of the loudspeaker." Had the measuring microphone been placed elsewhere, a different plot would have been obtained. Indeed, there are as many impulse responses as there are possible microphone positions. There is no easy way out, because a real loudspeaker and the

signal it receives are topologically mismatched. The one-dimensional, time-varying signal coming through the wires is transformed to an N-dimensional output, with very large N. Engineers who ignore this fact sleep more soundly, but the loudspeakers they design leave something to be desired.

Pushing "1" on the keyboard of the Apple II gets us a 128-point FFT, putting FIGURE 3B on the display screen. 128 points are only half of the plot of the impulse, so we are using as data only the first 2.75 milliseconds. We obtain a 64-line spectrum, with a resolution of about 360 Hz. This means that the first line after d.c. is 360 Hz, the next one is 720 Hz, then 1080 Hz, and so on. In terms of the logarithmic scale we are all familiar with in audio measurement, the resolution at low frequencies seems poor. However, by using a lower sampling rate—the standard IQS system will sample at a rate as low as 1 kHz—and an optional version at 200 Hz—as much as ten seconds of low frequency data can be taken in with a resolution of 0.1 Hz! Pushing "3" provides a more detailed display (FIGURE 3C), by doing a 512-point FFT, while pressing "4," generating a 1024-point FFT, shows us FIGURE 3D. In the last case, only half the frequency range is shown at a time. The last two FFTs used 11 and 22 seconds of data, and provide resolution of 90 Hz and 45 Hz respectively.

How do we arrive at these figures? We start with the sampling rate, which is 46.4875 kHz. Half this figure is the upper limit of measurement, 23.24 kHz, but in fact, only the range to 20 kHz is accurate because of the need to cut response above 23.24 kHz as sharply as possible to prevent data-sampling aliasing errors. To continue, dividing half the sampling rate by half the number of samples used in the FFT gives the frequency resolution. It is often simpler to divide the sampling rate by the length of the FFT for the same result.

FIGURE 3E shows the group delay measurement for the lower half of the frequency range, based on a 1024-point FFT, with the vertical scale calibrated at the right-hand side of the plot in milliseconds. Clearly, there is considerable delay at low frequencies and a small, probably imperceptible amount between 7 kHz and 8 kHz. The extreme variation above 10 kHz is almost certainly due to reflections on the cabinet from the metal grille, the mounting hardware, and the raised edge around the front of the cabinet. These reflections scatter the phase by interference and produce group delay results that look like random noise.

#### PSEUDO-ANECHOIC MEASUREMENTS WITH THE FFT

The impulse response plot in FIGURE 3A was made by carefully placing the loudspeaker on a stand one meter high at the center of a small laboratory cleared of any large furniture. The reflections produced by the surrounding walls arrived so late that they are not in the picture. FIGURE 4A shows a more typical situation, produced when the loudspeaker is in a position in which it is likely to be used by a listener at home, that is, against a wall with its driver units close enough to the floor to produce prominent reflections. At about 2.5 milliseconds we have a nearly perfect broadband reflection of the original impulse. Taking as a rule of thumb one foot and 1½ inches per millisecond (my thumb is dimensionally precise), the path length of the reflection is 2 feet 10 inches longer than the direct path from the loudspeaker to the microphone. In addition to this reflection, a number of others can be seen.

A 256-point FFT produces the spectral result in FIGURE 4B, ragged and noisy, because of the effects of the reflections. In fact, this is the total spectral result of everything seen to happen in the data shown in FIGURE 4A for the first 5.5 milliseconds after acquisition began, because the plot shows exactly the 256 points used for the FFT. By truncating the data, as in FIGURE 4C, we simulate anechoic conditions to some degree. To do so exactly, we would have to depend on the termination of the impulse response before the point of truncation, and locate the silent interval between the end of the impulse and the first reflection. This is very difficult to do when the loudspeaker produces ample low frequency output and is near the walls of the room, as low frequency components of the spectrum bounce around for quite a while. However, as FIGURE 4D shows, the

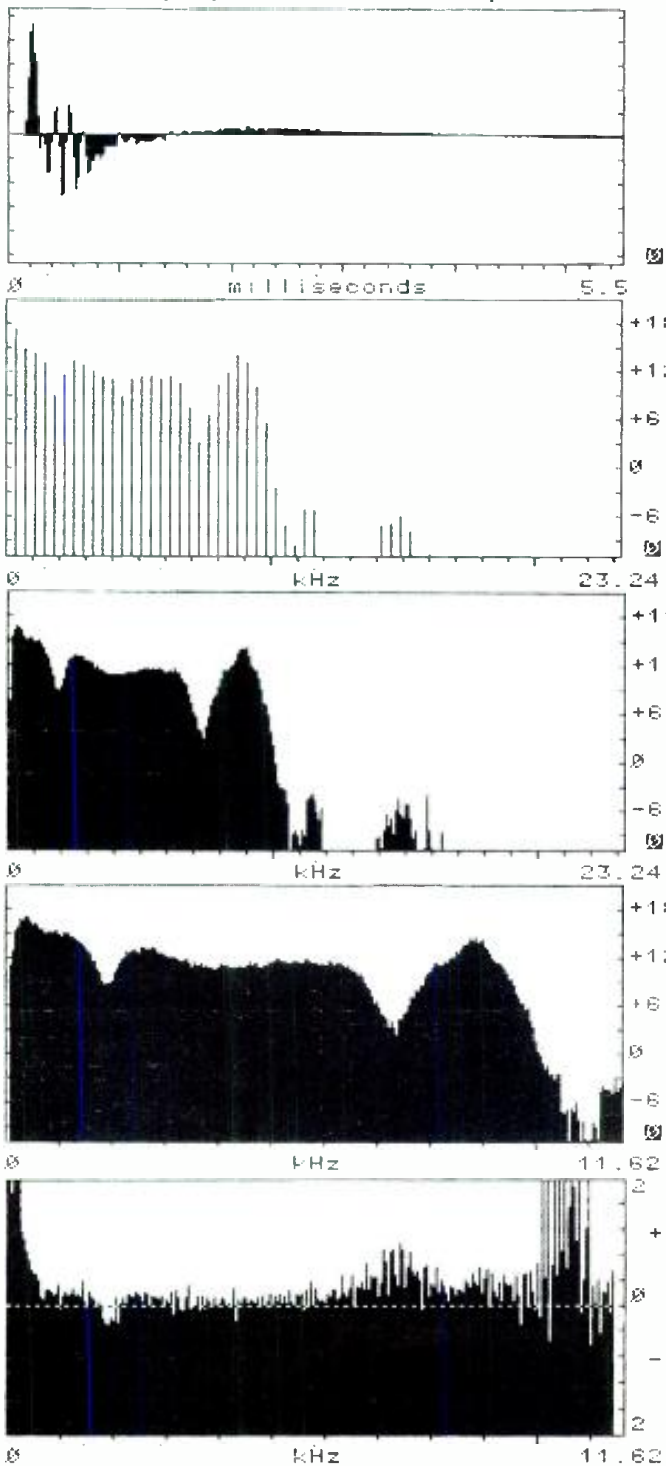

Figure 3. An impulse passed through a loudspeaker (A) produces the FFT response seen in the succeeding illustrations (B-E).



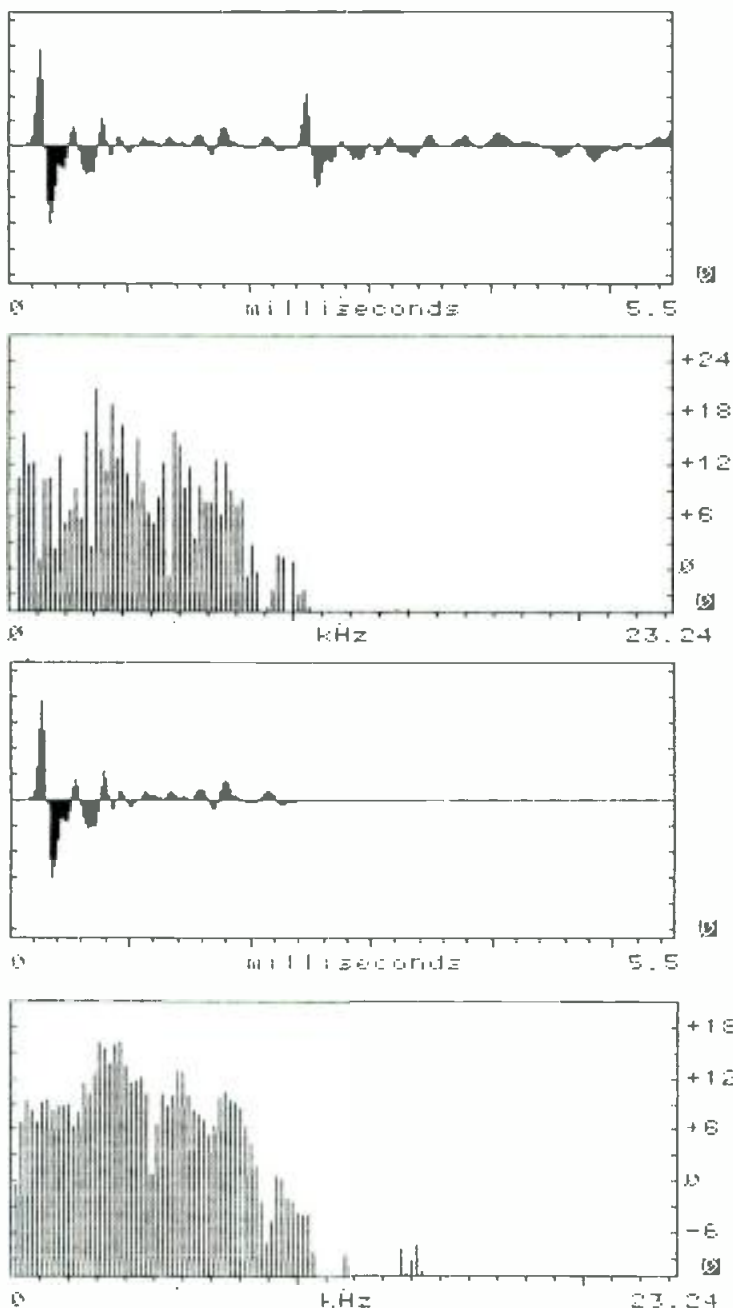

Figure 4. Impulse response of a speaker in a typical listening room (A), and a 256-point FFT (B). Anechoic conditions may be simulated by truncating the data (C), producing the FFT seen in (D).

first 2.4 milliseconds of the impulse response are not quite as bleak as might appear from the FFT of the un-truncated data. It is also clear that movement of the loudspeaker would probably improve stereo imaging substantially by eliminating strong cancellation effects occurring throughout the frequency range.

Reducing the length of the data sequence used, whether by truncation or by use of a smaller FFT, produces a smoothing effect that reduces resolution. In the truncation example just shown, for example, the number of data points was reduced from 256 to 112. Even though the number of lines in the spectrum remains 128, there is a spreading of the data in the results that corresponds to changing from narrow-band to slightly wider-band filters in a conventional spectrum analyzer. This is completely separate from the removal of the reflections, which introduces another kind of smoothing by eliminating interference. However, the same kind of smoothing, due to shortening of the data sequence, takes place when a loudspeaker has an impulse response that is of very brief duration. The frequency response curve will be very smooth, showing few perturbations and none which are very small. In such circumstances, taking larger and larger FFTs cannot add to the information presented, but does give a more presentable plot.

## SPECTRUM-VERSUS-TIME PLOTS

One nice feature of the IQS system is its ability to produce plots of the spectrum with changing time, with the starting point and the interval between spectra adjustable. This kind of plot, suggested by Shorter of the BBC long before FFT days, has been extensively used since Fincham and Berman of KEF showed elegantly how well a computer could produce displays of this kind. By attaching the Apple II to the new, low-cost Hewlett-Packard 7470A plotter, FIGURES 5A and 5B were produced from the same data shown in FIGURE 3A.

The method used is to do an FFT using the 512 samples of data starting at sample 0, then the 512 samples beginning with sample 1, and so on. To produce the "mountain range" effect, however, it is necessary to plot the curves backward—a minor detail. Comparing the two plots, we see an interesting difference. FIGURE 5A shows some high ridges at high frequencies that suggest the occurrence of events which are, in fact, unreal. When we start the FFT with a sample well into the impulse response, we may begin in the middle of a section of the waveform with substantial amplitude. The FFT sees a steep vertical rise as the beginning of an impulse and reads this as having very large high-frequency components as a result. To be quite correct, the FFT has the property of circularity; it sees the test waveform not as a single event encompassed in the 256 points (or whatever) being tested, but as a wave that goes on indefinitely with its beginning tied to its end. Starting the FFT in the middle of the impulse creates a waveform that has this eternally repeated steep rise in every interval of the lowest frequency represented.

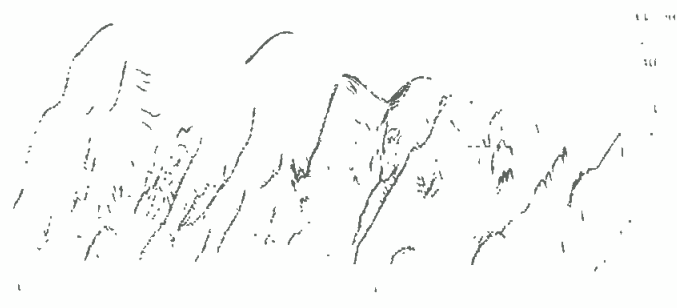
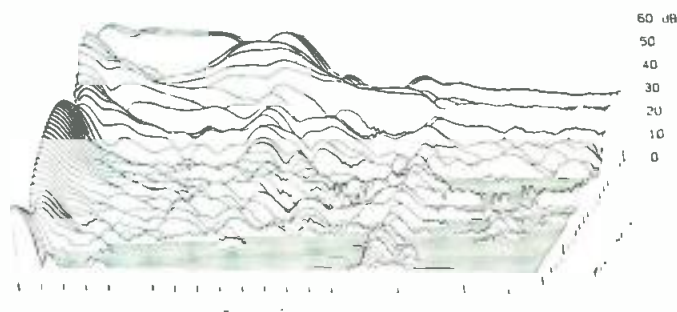

Figure 5. Computer-generated plots generated from the data taken from Figure 3.

The use of windows of different length and shape changes the appearance of the plots rather drastically, and suggests the need to find an optimum method of windowing. Whether or not such an idea is mathematically meaningful is unclear, but it is clear that the ear and brain—for which loudspeakers are designed—work in a quite different way. When we listen to a sound, windowing of a kind takes place, but the length of the window and to some extent its shape are different for every frequency. The way to study the performance of audio systems would seem to be to mimic this process, rather than to use a fixed window. We have been doing this at Acoustic Research for the past few years now...but that will have to be the subject of another article. ■

#### FOOTNOTES:

1. The IQS 401 FFT Analysis System is available from computer stores that deal with the technical community or from IQS, Inc., 5719 Corso di Napoli, Long Beach, California 90803. The system consists of a circuit board that plugs into the Apple II, with built in impulse generator, analog-to-digital and digital-to-analog con-

version, sampling rate and anti-aliasing filters under software control, complete software (including a speedy machine code FFT stored on a chip) and a detailed manual.

2. Here is a chance to pick up on something very interesting. The increased precision of location of the impulse in time as more frequencies are added has its exact counterpart in theories about the fundamental properties of the universe, that is, quantum mechanics. The example we have just been talking about makes it easier to deal with the idea that waves and particles are somehow the same thing if one is dealing with sufficiently minute quantities. In quantum theory every particle has associated with it a frequency proportional to its energy. Energy/momentum equals frequency times Planck's constant, remember? If the position of a particle in space is well defined by some experimental observation, its energy (frequency) will be spread over a large range of possible values. This corresponds to our impulse being exactly defined in time, by adding many frequencies together. On the other hand, if the energy (frequency) is established exactly, the position of the particle will be unknown. The same is true of the impulse: by assigning a definite frequency to it, we get a sine wave going to infinity past and future with no change...our impulse is nowhere. Setting either quantity to any precise value necessarily involves losing precision in the other quantity.

## A BASIC FFT Program

**L**INES 40 to 48 generate and store a decaying pulse by sampling the value of  $e^{-t} \sin(t)$ . The results go into the real array N, while the imaginary array P is zeroed at the same time (line 46). Lines 50 to 140 contain the part of the FFT program often called "the shuffle," in which the data is rearranged from its original sequence to one that simplifies and therefore speeds up movement of the products calculated later. Sometimes, a shuffle is done after the actual transform, instead of before, as in this example. Lines 150 to 270 are the transform, with stepping of sine and cosine values in line 200, complex multiplication in lines 240-242, and accumulation of products in lines 244-249. Lines 280 to 310 calculate and print out the results which have been stored in array S as the absolute values of the real and imaginary array elements in N and P. Users with computers other than the Apple II should skip to line 390, where a simple reversal of the data order (404-414) prepares for an inverse FFT. Flag V is set to 1 in line 420, to signal that it is an inverse FFT, and the program then jumps back to its start.

Lines 320 to 384 provide Apple II users with graphic output on the monitor screen, alternately showing the spectrum and the source signal itself as the program does forward and inverse FFTs, one after another.

The easiest way to experiment with this program is to substitute a new function in lines 40-48, possibly re-writing the program to allow manual entry of actual data. The automatic alternation of forward and inverse FFTs can be defeated by dropping lines 420 and 430 and moving the data reversal (lines 390 to 416) near the start and specifying the direction of the transform from the keyboard.

In practical FFT programs, the sine and cosine values are normally stored in a table and looked up by the program, rather than being called from the interpreter as here, to save time. This program has been adapted by the author from one written in FORTRAN and given in Stearns' "Digital Signal Analysis," published by Hayden, and available in most computer stores. It runs quite rapidly when compiled. However, even use of a BASIC compiler does not approach the speed of a program written directly in assembly language.

```

10 TEXT : V = 0
20 PRINT "VALUE OF N?": INPUT N
30 DIM N(N), P(N), S(N)
40 FOR I = 1 TO N
42 T = .375 * (I - 1)
44 N(I) = EXP (- T) * SIN (T)
46 P(I) = 0
48 NEXT I
50 MR = N: NN = N - 1
60 FOR M = 1 TO NN
62 L = N
70 L = L / 2
80 IF (MR + L) > NN THEN 80
100 MR = MR - L * (INT (MR / L)) + L
110 IF MR <= M THEN 140
120 TR = N(M + 1)
122 N(M + 1) = N(MR + 1)
124 N(MR + 1) = TR
130 TI = P(M + 1)
132 P(M + 1) = P(MR + 1)
134 P(MR + 1) = TI
140 NEXT M
150 L = 1
160 IF L >= N THEN 280
170 IS = 2 * L
180 EL = L
190 FOR M = 1 TO L
200 A = 3.14159265 * (I - M) / EL
210 WR = COS (A)
215 WI = SIN (A)
220 FOR I = M TO N STEP IS
230 J = I + L
240 TR = WR * N(J) - WI * P(J)
242 TI = WR * P(J) + WI * N(J)
244 N(J) = N(I) - TR
246 P(J) = P(I) - TI
248 N(I) = N(I) + TR
249 P(I) = P(I) + TI
250 NEXT I
255 NEXT M
260 L = IS
270 GOTO 160
280 FOR K = 1 TO N / 2 + 1
290 T = SQR (N(K) * N(K) + P(K) * P(K))
295 IF V = 1 THEN T = T / N
300 S(K) = T
305 PRINT S(K)
310 NEXT K
315 INPUT "PRESS ANY KEY TO DISPLAY GRAPHICS. "; K$
320 Q = 0: R = 279 / (N / 2 + 1)
330 FOR I = 1 TO N / 2 + 1
340 IF S(I) > Q THEN Q = S(I)
350 NEXT I
360 FOR I = 1 TO N / 2 + 1
362 S(I) = 159 - 159 * (S(I) / Q)
364 NEXT I
370 HGR
375 HCOLOR = 3
380 FOR I = 1 TO N / 2 + 1
382 HPOINT I * R - 1, S(I) TO I * R - 1, 159
384 NEXT I
390 IF V = 1 THEN 430
400 FOR I = 2 TO N / 2
402 X = N - I + 2
404 Y = N(X)
406 N(X) = N(I)
408 N(I) = Y
410 Y = P(X)
412 P(X) = P(I)
414 P(I) = Y
416 NEXT I
420 V = 1: GOTO 50
430 V = 0: GOTO 50
440 END

```



## The New York Center for Media Arts Adds a School of Audio Arts

**T**HE BIG APPLE has long been a major draw for young people seeking careers in the recording, television, photography and advertising industries. However, few of these people have much more than desire going for them, and finding work can be difficult, frustrating, and finally, a disappointing experience. Even the four-year college education makes no guarantee of employment.

Enter the Center for the Media Arts, a two-year-old consortium of schools for video (formerly RCA Institutes), photography (The Germain School), and advertising art and design (The Pels School). The Center recently purchased a \$4 million building on Manhattan's West 26th Street, to combine these schools, and the new School of Audio Arts, under one roof. A \$1 million renovation of the ten-story, 100,000 sq. ft. building has been underway since last spring, with the Center planning to be operational in time for the fall '82 semester.

The School of Audio Arts was designed, and will be directed, by Harry Hirsch, founder designer of two of New York's leading recording studios, MediaSound and Soundmixers. Hirsch is first vice-president and chairman of the Education Committee of the New York chapter of NARAS (National Academy of Recording Arts and Sciences), as well as adjunct professor, NYU School of Music Business Technology. Stressing hands-on learning, the school will provide students with individual work stations for music recording, sweetening, editing and mixing, and for equipment maintenance.

According to Hirsch, Scott Cannell (the Center's VP of program development) wanted to develop a broad-based curriculum that would help prepare students for audio work in film, video, radio and multi-media, as well as for all facets of the recording studio industry. "He was not particularly interested in just building a recording studio and producing mixers. So, we developed a 700-hour program highlighted by 430 hours of hands-on workshops emphasizing the three major areas of audio training: craft and creativity, business and management, and repair and maintenance.

"Each work station will be equipped with a Ramsa 12-in./4-2-1 out multi-track console, fed by a central 16-track recorder that will play back music programs in various instrumentations (including piano and voice, rhythm section, big bands and small groups with chorus). The program will be fed into each work station, where the student will do a mixdown assignment on a reverb-equipped console, monitoring by headphones. The mix will be done on a stereo cassette, which will be graded. The students will spend 100 hours completing this phase of the program.

"One course that's sure to be popular is 'Mixing for Video and Film,'" Hirsch adds. "Our mixing lab will have a large MGA four-foot video projector and synchronized tape recorder. Using SMPTE time code, our students will gain some first-hand experience syncing picture with sound."



*in the background, Harry Hirsch (complete with an official Otari tee-shirt) tries to imagine what it will all look like when it's finished.*

The school's edit lab will be equipped with 15 Otari 5050B two-track machines. Prepared edit assignments will incorporate work and master reels with headphone monitoring. A state-of-the-art recording studio, large enough to hold 40 musicians, will boast an MC1 32-in/24-out board, 24 tracks of Dolby noise reduction, an Otari MTR-90 24-track recorder and a variety of microphones.

A small announcer's booth and two isolation areas will be cued into the Center's School of Television Arts, so that visual information may be sent through video switchers providing the capability of producing programming for cable television. The school is presently negotiating with the music departments of several area colleges to provide musicians for recording sessions. The new building will even house a 2,000 sq. ft. video/sound stage, hooked into a 24-track control room complete with loudspeaker monitoring, intercom and video circuits. Conceivably, a symphony orchestra could be recorded, then edited and mixed upstairs in the Audio Arts labs.

Students will be required to complete 100 hours of Electronics I lab, including sessions in AC/DC circuitry, and semi-conductor electronics. This is to provide the foundation that Hirsch feels is necessary in order to go on into troubleshooting, repairing and maintaining the complex audio equipment found in the contemporary recording studio.

Hirsch has promised (are you reading this, Harry?) to deliver a full construction story as soon as the work is over. (Well, maybe the day after.)

## STEREO SLAVE



- Integrated Sound Systems has recently introduced the TDM-8200 Stereo Slave. When coupled with the TDM-8000 Audio Time Compressor, stereo sound tracks can be compressed without altering the original pitch and tone. The TDM-8000/8200 produces a stable, time-synchronized stereo image by making intelligent logic splicing decisions between channels. Vocal and instrumental sounds that are common to both channels will remain stable with respect to stereo image, and processed stereo sound tracks can be played in the monaural mode, without cancellations or other adverse effects. Radio real-time applications include not only stereo FM, but stereo AM as well, since the audio processing is completely compatible with any of the stereo AM systems. The TDM-8000/8200 is used with Type C broadcast video recorders, 1/2-in. variable-speed video cassette decks, variable-speed turntables, and audio tape machines. The TDM-8000/8200 compresses stereo music up to 1.5 times, and maintains high frequency response and dynamic range, while allowing very little distortion. At any point from 1 to 1.5 times compression of original material, the frequency response is 20 Hz to 15 kHz, the dynamic range is 81 dB, and the THD, 1M, and noise is never greater than 0.3 percent.

*Mfr: Integrated Sound Systems, Inc.*

*Price: TDM-8000: \$4,995.00;*

*TDM-8200: \$2,800.00*

*Circle 40 on Reader Service Card*

## 4-BAND PARAMETRIC EQUALIZER



- The PE-40 rack-mountable parametric equalizer is a high resolution alternative to more common graphic and quasi-parametric type EQ. The PE-40 has four identical channels which may be used to process four discrete programs, or the channels can be cascaded when more extensive frequency correction is necessary. Each of the PE-40's four channels has four overlapping bands. Center frequencies may be swept from 40-800 Hz, 500 to 10 kHz, and 800-16 kHz. A concentric knob adjusts the "Q" (sharpness) of each band from 1.1 to 5 so that a broader or narrower band of frequencies is affected. A separate knob adjusts each band's gain for up to 15 dB of boost or cut. In PA work, the PE-40 can be tuned to the exact center of each feedback node. In addition to the parametric EQ, each channel has three push button-selectable filters, two high pass and one low pass. The 60 Hz, 18 dB octave filter cuts out rumble, motor noise and other subsonics while the 160 Hz, 6 dB octave filter reduces wind noise and further increases gain before feedback to avoid howling in PA work; both high pass filters can be combined for an even steeper low frequency roll-off. The 15 kHz, 12 dB octave LP filter can be used to reduce hiss, cut leakage from adjacent instruments, etc.

*Mfr: TASCAM*

*Circle 41 on Reader Service Card*

## GRAPHIC EQUALIZER



- The Model 160 Graphic Equalizer provides a  $\pm 12$  dB of correction capability at the center frequencies of the 10 octaves which encompass the musical spectrum. For matching the output between equalized and bypass modes,  $\pm 8$  dB of overall level adjustment is provided. Each of the slide controls is center tapped to ground in the flat position, so that all frequency selective networks are balanced out of the signal path. The 160 also provides an optional microphone and a test disk of band-limited pink noise. The microphone plugs into the equalizer, which provides a front panel LED readout of level as each band is played, enabling correction of each, independently for each channel, at the listening position. In addition to the inclusion of a tape monitor function, a Record switch enables the equalizer to be inserted into either the record or the playback path of the tape machine connected to the monitor. The 10-LED front panel display provides standard increments from -20 to +3 dB, and when the microphone is not connected, they show the overall output level. Two sensitivity ranges are provided.

*Mfr: David Hafler Company*

*Circle 42 on Reader Service Card*



# 25,000 copies in print

## The Recording Studio Handbook



John M. Woram

### Fifth big printing of the definitive manual of recording technology!

"John Woram has filled a gaping hole in the audio literature. This is a very fine book . . . I recommend it highly."  
— *High Fidelity*. And the *Journal of the Audio Engineering Society* said, "A very useful guide for anyone seriously concerned with the magnetic recording of sound."

So widely read . . . so much in demand . . . that we've had to go into a fifth printing of this all-encompassing guide to every important aspect of recording technology. An indispensable guide with something in it for everybody to learn, it is the audio industry's first complete handbook on the subject. It is a clear, practical, and often witty approach to understanding what makes a recording studio work. In covering all aspects, Woram, editor of *db Magazine*, has provided an excellent basics section, as well as more in-depth explanations of common situations and problems encountered by the professional engineer.

It's a "must" for every working professional . . . for every student . . . for every audio enthusiast.

### 8 clearly-defined sections 18 information-packed chapters

#### I. The Basics

The Decibel  
Sound

#### II. Transducers: Microphones and Loudspeakers

Microphone Design  
Microphone Technique  
Loudspeakers

#### III. Signal Processing Devices

Echo and Reverberation  
Equalizers  
Compressors, Limiters and Expanders  
Flanging and Phasing

#### IV. Magnetic Recording

Tape and Tape Recorder  
Fundamentals  
Magnetic Recording Tape  
The Tape Recorder

#### V. Noise and Noise Reduction

Noise and Noise Reduction  
Principles  
Studio Noise Reduction Systems

#### VI. Recording Consoles

The Modern Recording  
Studio Console

#### VII. Recording Techniques

The Recording Session  
The Mixdown Session

#### VIII. Appendices

Table of Logarithms  
Power, Voltage, Ratios and Decibels  
Frequency, Period and Wavelength of Sound  
Conversion Factors  
NAB Standard  
Bibliography  
Glossary

Use the coupon to order your copies today at \$37.50 each. And there's a 15-day money-back guarantee.

#### ELAR PUBLISHING COMPANY, INC.

1120 Old Country Road, Plainview, N.Y. 11803

Yes! Please send \_\_\_\_\_ copies of THE RECORDING STUDIO HANDBOOK. \$37.50. On 15-day approval.

Name \_\_\_\_\_

Address \_\_\_\_\_

City/State/Zip \_\_\_\_\_

Total payment enclosed \$ \_\_\_\_\_  
(In N.Y.S. add appropriate sales tax)

Please charge my  Master Charge  
 BankAmericard/Visa

Account # \_\_\_\_\_ Exp. date \_\_\_\_\_

Signature \_\_\_\_\_  
(charges not valid unless signed)

Outside U.S.A. add \$2.00 for postage.  
Checks must be in U.S. funds drawn on a U.S. bank.

Closing date is the fifteenth of the second month preceding the date of issue.  
 Send copies to: Classified Ad Dept.  
**db THE SOUND ENGINEERING MAGAZINE**  
 1120 Old Country Road, Plainview, New York 11803

Minimum order accepted: \$25.00  
 Rates: \$1.00 a word  
 Boxed Ads: \$40.00 per column inch  
 db Box Number: \$8.50 for wording "Dept. XX," etc.  
 Plus \$1.50 to cover postage

Frequency Discounts: 6 times, 15%; 12 times, 30%

ALL CLASSIFIED ADS MUST BE PREPAID.

THE LIBRARY... Sound effects recorded in STEREO using Dolby throughout. Over 350 effects on ten discs. \$100.00. Write **The Library, P.O. Box 18145, Denver, Colo. 80218.**

FOR SALE—WHITE 3900 narrow band filter system for control of feedback and ring modes. 95% complete. \$3,000.00. Call for details. **Ron (216) 699-9975.**

FOR SALE: YAMAHA PM 1000-24 mixing console. 32 main frame. Carlo ATA case. gooseneck lights, excellent condition. Must sell—best offer. **Mark Lowrance (901) 885-4504.**

USED RECORDING equipment for sale. **Dan (415) 441-8934.**

## FOR SALE

**FREE 32pg Catalog & 50 Audio/Video Applic.**



Video & Audio Dist. Amplifier  
 PWR SUPP. EQ.  
 PHONO, MIC, TRANS. ACN.  
 TAPE, VIDEO, LINE, OSC.  
 Stereo Mono Pwr Ampl.  
 8-in. 2-out, 12-in. 4-out, 16-in. 4-out  
 TV Audio & Recd Prod Consoles

**OPAMP LABS INC (213) 934-3566**  
 1033 N Sycamore Av LOS ANGELES CA, 90038

REELS AND BOXES 5" and 7" large and small hubs, heavy duty white boxes. **W-M Sales, 1118 Dula Circle, Duncanville, Texas 75116 (214) 296-2773.**

ROCKET STUDIOS—All inventory. Teac 90-16, Pioneer 4-2 track, Allen-Heath modified 16 x 8 x 16, Neumann, Ecoplate, AKG, much more, complete studio \$50,000. **(303) 567-2965, (303) 526-1881.**

SCULLY 284-8 TRACK tape machine w/sync master. Best offer. **Birch Recording Studio, Secretary, Maryland. (301) 943-8141.** Reason for selling, gone 16 track.

ORBAN and LEXICON. All products in stock. FOR IMMEDIATE DELIVERY. **UAR Professional Systems, 8535 Fairhaven, San Antonio, TX 78229. 512-690-8888.**

FOR SALE AKG C-24 and other tube type condenser mics. **(415) 441-8934 or 527-6167.**

### - ANNOUNCING -

## "LOUDSPEAKER ARRAYS - A GRAPHIC METHOD OF DESIGNING"

Now the design of loudspeaker arrays is as easy as the design of the rest of the sound system. Our method is easy to use, is fast and accurate!

We will design your array or do any of the steps you don't want to do in the array design process.

Either way, you end up with a description of the array, and drawings from as many views as you want.

Call or write: **(612) 871-6446**

\* **north star sound UMBULUS**  
 1406 First Avenue South  
 Minneapolis, MN 55403  
 Thomas McCarthy, Chief Engineer



WANT TO ELIMINATE FEEDBACK HOWL WITHOUT GAIN REDUCTION... ACTUALLY WITH INCREASED GAIN? FIND OUT ABOUT OUR FEEDBACK STABILIZERS MOD. 741XR & 742XR.

**BODE SOUND CO.**  
 1344 ABINGTON PL.  
 NO. TONAWANDA, N. Y. 14120  
 716.692.1670

### PROFESSIONAL AUDIO EQUIPMENT

Shop for pro audio from N.Y.'s leader, no matter where you live! Use the Harvey Pro Hot Line (800) 223-2642 (except N.Y., Ak. & Hi.). Expert advice, in-depth parts dept., 3/4" video systems available. Broadest selection such as Otari, Quad Eight, Soundcraft, Tascam and more. Write or call for price or product info:

**Harvey Professional Products Division**  
 25 W. 45th Street  
 New York, NY 10036  
 (212) 921-5920





#### ACOUSTIC TEST INSTRUMENTS

USE TO ADJUST EQUALIZERS, OPTIMIZE SPEAKER PLACEMENT, ETC.

|  |       |
|--|-------|
| Complete Test Set  | \$449 |
| Calibrated Sound Level Meter   | \$199 |
| Fractional Octave Pink Noise Generator   | \$339 |
| Handbook on Acoustic Testing   | \$10  |
| Free broch. HALL ENGINEERING, Dept. ES<br>P.O. Box 506, Martinsville, NJ 08836<br>(201) 647-0377 |       |

#### THE MOST FLEXIBLE MICROPHONE & SNAKE CABLE

Available...1 to 24 pairs. No jacket shrinkage while soldering. Call/Write for FREE CATALOG. **BI-TRONICS Inc., Dept. D, Box 125, Tuckahoe, NY 10707. (212) 585-1645.**

FOR SALE: U.R.E.I. Model 100-A Sonipulse acoustical audio system analyzer with AKG C-451-E calibrated microphone. Excellent condition. \$600 or best offer. **Call Tom at (215) 374-2784.**

AMPEX, OTARI, SCULLY—In stock, all major professional lines; top dollar trade-ins; write or call for prices. **Professional Audio Video Corporation, 384 Grand Street, Paterson, New Jersey 07505. (201) 523-3333.**

CUSTOM LENGTH CASSETTE BLANKS made to order featuring AGFA, Scotch, and Magnetic Media tape, any length from C-2 through C-122. For pricelist write **M & K Recordings, Box 195d, Mt. Morris, MI 48458 or call (313) 687-7610.**

#### SERVICES

MAGNETIC HEAD relapping—24 hour service. Replacement heads for professional recorders. **IEM, 350 N. Eric Drive, Palatine, IL 60067. (312) 358-4622.**

ACOUSTIC CONSULTATION—Specializing in studios, control rooms, discos. Qualified personnel, reasonable rates. Acoustilog, Bruel & Kjaer, HP, Tektronix, Ivie, equipment calibrated on premises. Reverberation timer and RTA rentals. **Acoustilog, 19 Mercer Street, New York, NY 10013 (212) 925-1365.**

#### INSTRUCTION

SHERMAN KEENE CORRESPONDENCE course. Author of acclaimed textbook "Practical Techniques for the Recording Engineer" invites you to study recording at home. Course includes reading and homework assignments in two textbooks with personal dialog via cassette. Eight lessons per level, 3 levels. \$250 per level. For info write: **Correspondence Course, 1626 N. Wilcox No. 677D, Hollywood, CA 90028.**

#### WANTED

WANTED: TRANSCRIPTION discs, any size, speed. Radio shows, music. **P.O. BOX 724—db, Redmond, WA 98052.**

## UH-OH!



Have you misplaced your db again? Our high quality, royal blue vinyl binders keep 12 copies of db neat and handy for ready reference.

Just \$9.95, available in North America only. (Payable in U.S. currency drawn on U.S. banks.) **ORDER YOURS NOW!!**

#### Sagamore Publishing Co., Inc.

1120 Old Country Road  
Plainview, NY 11803

**YES!** Please send \_\_\_\_\_ db binders (at \$9.95 each, plus applicable sales tax, Total amount enclosed \$ \_\_\_\_\_)

Name \_\_\_\_\_

Company \_\_\_\_\_

Address \_\_\_\_\_

City \_\_\_\_\_

State/Zip \_\_\_\_\_

MCI JH-416 CONSOLE 18 x 16 x 24, all factory updates. headroom kit, selectable mid-range dip. (EQ comparable to 428) full patch facilities, matching walnut producer's desk. \$11,000 or offer. Also, extra JH-416 input modules and Mellotron. **(612) 774-4857.**

REMANUFACTURED ORIGINAL equipment capstan motors for all Ampex and Scully direct drive recorders, priced at \$250., available for immediate delivery from **VIF International, P.O. Box 1555, Mtn View, CA 94042, phone (408) 739-9740.**

BLANK AUDIO AND VIDEO CASSETTES direct from manufacturer, below wholesale, any length cassettes: 4 different qualities to choose from. Bulk and reel mastertape—from 1/4-inch to 2-inch. Cassette duplication also available. Brochure. **Andol Audio Products, Inc., Dept. db, 42-12 14th Ave., Brooklyn, NY 11219. Toll free 1-800-221-6578, ext. 1, NY residents (212) 435-7322.**

MASTER THE RECORDING SCIENCE. Sherman Keene's "Practical Techniques for the Recording Engineer" is a book about the real world of studio recording. Acclaimed by magazines, reviewers, college teachers, studio owners and engineers. 381 pages, 28 chapters (4 on computer mixing). To order send \$29.75 plus 6% (Calif. only) and \$2.75 shipping to: **Sherman Keene Pub., 1626 N. Wilcox No. 677-D, Hollywood, CA 90028.**

SURPLUS JBL TWEETERS. NEW. Ideal for disco tweeter arrays or improving sound reinforcement and home loud-speaker systems. Specify choice of bullet or slot lens type. \$80 plus \$2 shipping each. Add sales tax if in NY. **Rosner Custom Sound, 11-38 31 Ave., L.I. City, NY 11106. (212) 726-5600.**

AUDIOTRONICS CONSOLE—#501 son of 36 grand, 24 track, 26 inputs, custom or regular E.Q. (your choice). \$15,000.00. With factory installation, \$16,000.00. Neumann Cutting System with SX 68 hd, P.D.M. Limiter, Variable Pitch, Variable Depth, Control Panel, Tape Recorder with Preview HDS., and speakers. \$45,000.00. Westlake speakers \$2,000.00. 16 Channel dbx \$5,000.00. **Call Paul (312) 225-2110 or (312) 467-9250.**

# People..Places..

• **Digital Sound Recording** is proud to announce the appointment of **Sandy Taylor** as vice president director in charge of Technical Marketing Services including film, video, music and digital recording. The announcement was made by DSR president **Van Webster** who reports that, "...due to heavy bookings of recent months in video and music projects, the addition of a technical marketing director is essential to providing our clients with the best services possible." Taylor was formerly administrative vice president general manager of **Anchor Leasing Corporation**.

• **Robert Pabst**, president of **Electro-Voice, Inc.**, has announced the following staff changes. **Paul McGuire** has been promoted to National sales manager; **Greg Hockman** has joined Electro-Voice as Marketing Manager, Music Products; and **Jesse Walsh** comes on board as Central Region sales manager. McGuire's tenure with Electro-Voice dates back to 1972. In his position as National sales manager, he will oversee all Electro-Voice sales activities in the Pro Sound, Music Industry, Broadcast and Recording, Commercial Sound, and Consumer Hi-Fi markets. McGuire's most recent position with Electro-Voice was as director of Marketing Music Products.

• **Jerome C. Smith** has been named **Cerwin-Vega's** director of Digital Development. The appointment was announced by **Larry Phillips**, President of Cerwin-Vega International. Smith will be responsible for the development and marketing of digital products, primarily loudspeaker systems for both residential hi-fi use and recording studio monitors. Smith's immediate duties are to develop and assist in marketing plans for the recently introduced Digital Series of residential loudspeakers and also to consult in the development and marketing of a new line of "digital ready" recording studio monitors. Previous to joining Cerwin-Vega, Smith was an independent consultant specializing in recording studio acoustics and playback systems. He was also a founder and owner of **Express Sound Company**, a firm that designed and installed sound reinforcement and playback systems for a variety of recording facilities. Smith was a training manager at **Teac** and founded **The Sound Factory**—a retail store specializing in musical instrument and sound reinforcement products.

• **Dan Tynus**, vice-president and general manager of **Sound Studios**, announced recently that he and a group of investors have purchased the registered trademark name of "Quantitape" and its tape duplicating equipment from its parent company in New York, **Diversa-Graphics, Inc.**, and have formed a new corporation called **Quantitape Duplicating, Inc.** Quantitape is a state-of-the-art facility capable of duplicating all industry formats, including critical stereo music and pulsed AV presentations. A complete line of private label blank cassettes will be introduced for a wide range of user applications. In addition to tape services, another dimension to the company is a new division called **Quantidisc**. It will do record mastering and produce pressings. Floppy disc reproduction plans are in the offing.

• Acting on recommendations made by the Board of Directors, the Executive Committee of the **National Radio Broadcasters Association** has voted to appoint an executive vice president to manage the affairs of the association and to facilitate a planned expansion of NRBA's activities. A recent survey and study conducted among NRBA Board members by Board Chairman **Bill Clark** developed a consensus for taking prompt action to accelerate the association's recent, rapid growth. The Board suggested an expansion of member services and an intensification of the already highly successful member recruitment campaign. The Board also directed a maximum effort to achieve true and full deregulation through legislation.

• **Frank Santucci**, well-known in both the audio and video industries, has founded **Advanced Marketing**. Advanced Marketing is an independent manufacturer's representative that is dedicated to serving the audio video marketplace by offering top-quality equipment for broadcast, production and post-production. Mr. Santucci brings more than 20 years experience to AM, having been senior product manager for **Ampex**, marketing manager for **Orban** and most recently National sales manager for **Harris Video Systems (CVS)**. Initial product lines to be offered by Advanced Marketing will be **Hedco** (routing switchers, distribution equipment), **Asaca/Shibasoku** (color monitors, signal generators, test equipment) and **United Media** (computer-assisted editors, SMPTE time code equipment).

• **Altec Lansing** president **William Fowler** recently announced the hiring of Mr. **William Chambers** as new vice president of Marketing and Strategic Planning for the Anaheim-based manufacturer of commercial and home sound system products. With extensive experience in marketing planning and analysis, Chambers comes to Altec after 19 years with **Black and Decker** and subsidiary company **McCulloch**. At Altec, Chambers will be involved in analyzing the Company's current business activities and their relation to optimizing future market opportunities.

• **WNVC**, a new non-commercial educational TV station serving Northern Virginia, will begin broadcasting this fall with **RCA** transmitting systems valued at approximately \$1 million. The new equipment, on order from **RCA Commercial Communications Systems Division**, includes a **TTU-601D**, 60-kilowatt UHF transmitter, and a **TFC-33J** pylon antenna. Also included in the equipment order are four **RCA** studio and electronic newsgathering cameras which will be used in **WNVC's** new studio facilities. **WNVC** will be operated by the **Central Virginia Educational TV Corp.**

• **BGW Systems, Inc.** has appointed **Theatre Projects Limited** as exclusive distributor for all **BGW Systems** professional and commercial power amplifiers in the United Kingdom. The announcement was made by **BGW Systems** sales manager, **Irwin Laskey**. As exclusive distributor, **Theatre Projects Limited** will offer the complete **BGW Systems** line, including the **PROLINE™** power amplifiers.

• **Lynette Robinson** has been promoted to Executive Secretary of the **Society of Motion Picture and Television Engineers (SMPTE)**, the top SMPTE staff position. It was announced by SMPTE President **Charles E. Anderson, Ampex Corp.** As Executive Secretary, Mrs. Robinson will be in charge of SMPTE Headquarters with responsibility for supervising the SMPTE staff and acting as liaison between SMPTE officers and Headquarters. She will also be involved in coordinating SMPTE conference activities, including finances, registration, and exhibits. Mrs. Robinson has been on the SMPTE staff for eight years. Prior to her promotion to Executive Secretary, she was manager of Conference Programming, Scheduling, and Sections.



# ... & Happenings

## Computing on the Road

If you've been putting off going on the road because you just can't bear to be separated from your computer, you have a friend at Hewlett-Packard. Over the past few months, the company has introduced a variety of almost-pocket-sized computers, some of which may be interfaced with a color TV set or video monitor.

The latest entry is the battery-operated HP-75 Portable Computer, which will handle 169 instructions, including 147 BASIC commands. You can work out your programs on the road, and store them on magnetic cards, using the built-in card reader/writer. When you get back to the hotel at night, you can read up to 16 lines of 32 characters each, by interfacing the

HP-75 with the TV, using the HP-82163 Video Interface. The interface will also work with the HP-41 series of calculators.



*The HP-75 features a miniature "QWERTY" keyboard for entering BASIC instructions.*



*The video interface (lower left) lets you see your programming efforts on any TV set or video monitor.*

labels the opportunity to transfer their "hot" library albums from analog to digital for a processing charge only. If this project comes to fruition, it will solidify our place in the industry as the certifying agency for digital music. Who is better qualified to tell the consumer the difference between analog and digital music than SPARS studios? We have a chance not only to authenticate the recording of tomorrow's music, but also to have the SPARS logo become a recognized symbol of excellence to assure the consumer that the product has been properly produced.

Apparently, not everyone thought this was a good idea. Digital Sound Recording's Van Webster had this to say to SPARS president Chris Stone:

I am deeply concerned by your comments suggesting that SPARS and a "leading digital equipment manufacturer" are planning to enter into a "massive project" to offer record labels the opportunity to transfer their "hot" library albums from analog to digital for a processing charge only. The implications of such a project are staggering to a digital audio marketplace which is already suffering from an excess of production capacity. It is outrageous to me to think that SPARS would offer such a service with free equipment when studios, including your own, have purchased digital recorders and must support them while "the club" offers the same service for a nominal charge. Two

## SPARS News

The following news item appeared in a recent SPARS newsletter:

We are pursuing a massive project with a leading digital equipment manufacturer who is considering providing us with the equipment necessary to offer

# ..More Happenings

of the featured speakers at your road shows have promoted the virtues of digital archiving as a business enterprise and now SPARS wants to cut off that business from the very studios it was formed to represent.

In addition, the unnamed manufacturer is short-circuiting his own sales by going into competition with his customers. This practice is not without precedent, even in the digital audio field, but should hardly be encouraged, let alone supported by an organization such as SPARS.

If SPARS wants to promote digital archiving by having its members who have purchased and paid for digital recorders offer to the labels a low-cost sample run, then the marketplace will be well served. If manufacturers, whose principal interest lies in retail sales, want to provide digital recorders to all and rebates to those studios who long ago made a financial commitment to digital audio, so much the better. But for a society that labels itself professional to go into competition with its own members and the community that it is pledged to serve, is greedy and unethical.

I remain sincerely yours.

VAN WEBSTER  
President  
Digital Sound Recording

c.c. Music Connection Magazine  
Pro Sound News  
Billboard  
Recording Engineer / Producer  
db  
Journal of The Audio Engineering  
Society  
Sony Corp.  
Studer  
JVC  
3M  
Neve

Webster's remarks are quite well-put, and in a written reply, SPARS' Chris Stone noted that "...the proposal has been over-ridden and cancelled by our Board of Directors, after discussions with our Advisory Associate members." According to Bart DiGrazia, SPARS Administrative Director, the Board's action was taken several weeks before Webster's letter arrived, suggesting that he was not the only one who objected to the proposal. And, on a cheerier note...

## On Tour with DISKMIX

Sound Workshop's new floppy disk-based DISKMIX automation storage/editing system recently came home from a demo tour of the major recording centers, including New York (Atlantic Recording Studios), Nashville (Soundshop Recording Studios), San Francisco (Harbor Sound) and Los Angeles (Pasha Recording Studios).

DISKMIX is easily interfaced with MCI JH-50, Sound Workshop ARMS, and Valley People 65K systems, and is a "chaser" system which follows the engineer's normal mixing moves. The system uses the multi-track recorder's SMPTE time code track to lock all automation data stored on the disk to the master tape.

Sound Workshop plans to supply continuous software updates, which will be free for the first year after system purchase. A special video production software package is now being designed.



Seated at the keyboard of the mighty DISKMIX system, Sound Workshop president Michael Tapes begins a demo mix for an SRO audience at New York's Atlantic Studios.



# The Needle Knows

Even when your ears can't tell the difference, your VU meters can.

Which is why we test every reel of our 2" Grand Master® 456 Studio Mastering Tape end-to-end and edge-to-edge. To make certain you get a rock-solid readout with virtually

no tape-induced level variations from one reel of 456 to another or within a single reel.

No other brand of tape undergoes such rigorous testing. And as a result no other brand offers you the reliable consistency of Ampex Tape.

A consistency that lets you forget the tape and concentrate on the job.

Ampex Corporation, Magnetic Tape Division  
401 Broadway, Redwood City, CA 94063  
(415) 367-4463

## AMPEX

Ampex Corporation • One of The Signal Companies

**4 out of 5 Professionals Master on Ampex Tape.\***

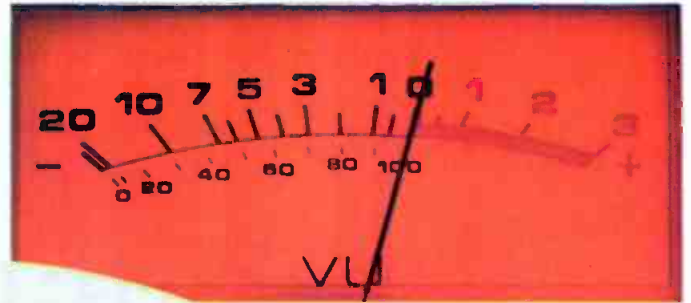

\*1981-1982 Billboard Magazine  
Brand Usage Survey

Circle 36 on Reader Service Card

# FROM OUR HANDS TO YOUR HANDS

*The Otari MTR-90 Series II  
8, 16, 24 Channel Master Recorders*

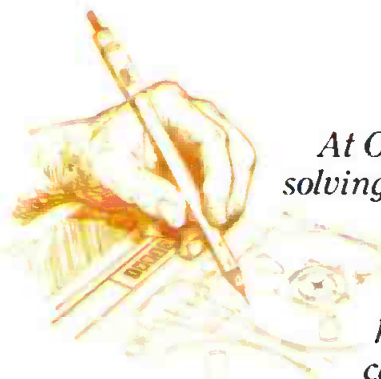

*At Otari, the focus of our work is on innovation and problem solving. These values are carefully reinforced by our dedication to quality; they are inherent in every tape recorder we engineer.*

*The new, second generation MTR-90 Series II multi-channel recorders are the embodiment of this philosophy. We have refined the features and extended the performance and capabilities of the MTR-90 by working closely with industry leaders who demand the extra measure of technology and commitment. With recording and film/video post-production facilities depending on the MTR-90, we've stayed close to the needs of today's media production houses. The new Series II machines are the logical result; a microprocessor-controlled recorder specifically designed to easily interface with any SMPTE-based video editing system, machine controller or synchronizer.*

*Once again, we've advanced the industry's most advanced recorders. And, kept the same dedication to the craftsmanship we've always had.*

*From our hands to yours, the new MTR-90 Series II recorders are engineered like no other tape machines in the world; with the quality you can hear and feel.*



**OTARI** Technology You Can Touch.

Otari Corporation, 2 Davis Drive, Belmont, CA 94002  
Tel: (415) 592-8311 Telex: 910-376-4890

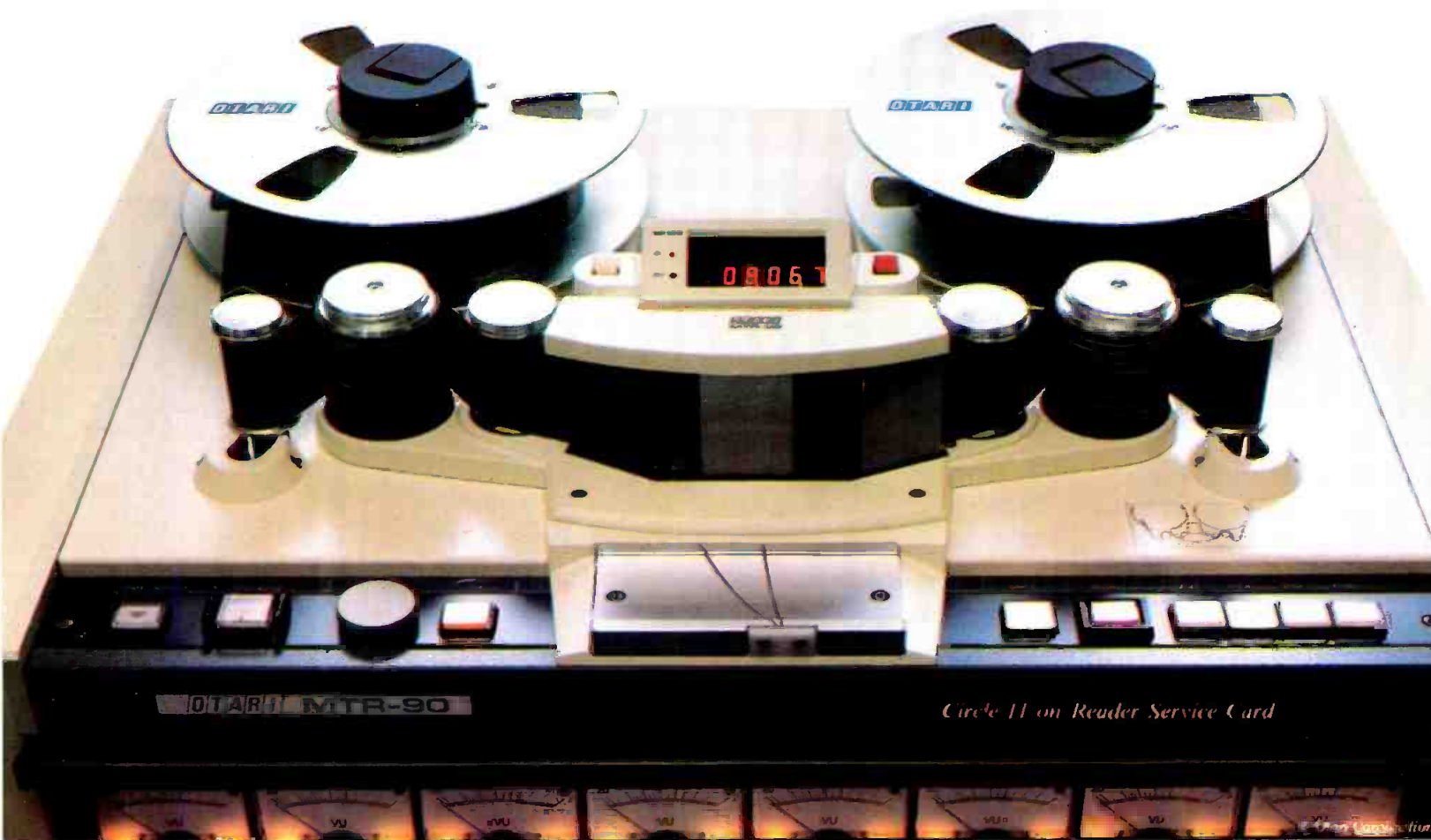

Circle 11 on Reader Service Card