

Hearing our full line is believing.

We've been helping the professional audio world to sound better since 1948. Every one of our products—from our low-cost portable to our top-of-the-line multi-track recorder—deliver that special Ampex Sound people love.

When it comes to professional audio, we've got you covered. Our audio family includes: the cost-efficient ATR-700, the worldly ATR-800 designed to meet

international broadcast standards, the incomparable ATR-100 ¼" and ½" mastering recorder, the rugged MM-1200 multi-track, and the advanced ATR-124 multi-track analog recorder. For details about any

exciting member of our professional audio family, call your local Ampex representative, or contact Willie Scullion, Ampex National Sales Manager, Audio-Video Systems Division, 401 Broadway, Redwood City, CA 94063 (415) 367-2911.

THE AMPEX SOUND

AMPEX

Ampex Corporation • One of The Signal Companies



Circle 25 on Reader Service Card

Publisher
Larry Zide

Editor
John M. Woram

European Editor
John Borwick

Associate Editor
Mark B. Waldstein

Production & Layout
David Kramer

Advertising Coordinator
Karen Cohn

Classified Advertising
Carol Vitelli

Book Sales
Lydia Calogrides

Circulation Manager
Eloise Beach

Art Director
Bob Laurie

Graphics
K & S Graphics

Typography
Spartan Phototype Co.

sales offices

Roy McDonald Associates, Inc.
Dallas, Texas 75207

First Continental Bank Bldg.
5801 Marvin D. Love Freeway
Suite 303
(214) 941-4461

Denver, Colorado Area
Englewood, Colorado 80112

14 Inverness Dr. East
Bldg. 1—Penthouse
(303) 771-8181

Houston, Texas 77036
6901 Corporate Drive
Suite 210
(713) 988-5005

Los Angeles Area
Glendale, California 91204
424 West Colorado Street
Suite 201
(213) 244-8176

Portland Area
Hillsboro, Oregon 97123
510 South First
P.O. Box 696
(503) 640-2011

San Francisco Area
Emeryville, California 94608
265 Baybridge Office Plaza
5801 Christie Avenue
(415) 653-2122

Sagamore Publishing Co.
New York
Plainview, NY 11803
1120 Old Country Rd.
(516) 433-6530



OCTOBER 1982 VOLUME 16, NO. 10

DEPARTMENTS

LETTERS
6

EDITORIAL
32

CLASSIFIED
65

DIGITAL AUDIO
12

SOUND REINFORCEMENT
20

THEORY AND PRACTICE
26

SOUND WITH IMAGES
30

NEW PRODUCTS AND SERVICES
62

PEOPLE, PLACES, HAPPENINGS
67

Barry Blesser

John Eargle

Ken Pohlmann

Len Feldman

FEATURES

AUDIO DISTORTION ON BOTH SIDES
OF THE GLASS
40

Murray Allen

DIGITAL AUDIO PROCESSING—
THE NEXT STEP
46

Anthony Agnello
and Mark Clayton

NEW SOUND IN THE ROUND: THE GREATEST
SHOW ON EARTH GOES OMNI
52

William Lobb

RECORDING STUDIO RENTALS—OR—YOU
DON'T HAVE TO OWN FLORIDA TO ENJOY IT
55

Hamilton Brosious

SOUND SYSTEM DESIGN THE ALTEC WAY
58

John M. Woram

About The Cover

• This month's cover features Can-Am Recorders' Studio A, a 24-track room featuring a Quad-8 Coronado automated console, an Otari MTR 90 recorder, JBL bi-radial monitors, Dolby noise reduction and a full array of outboard gear. The photo comes courtesy of Mark Elkins.

db, the Sound Engineering Magazine (ISSN 0011-7145) is published monthly by Sagamore Publishing Company, Inc. Entire contents copyright © 1982 by Sagamore Publishing Co., 1120 Old Country Road, Plainview, L.I., N.Y. 11803. Telephone (516) 433-6530. db is published for those individuals and firms in professional audio-recording, broadcast, audio-visual, sound reinforcement, consultants, video recording, film sound, etc. Application should be made on the subscription form in the rear of each issue. Subscriptions are \$15.00 per year (\$28.00 per year outside U.S. Possessions; \$16.00 per year Canada) in U.S. funds. Single copies are \$1.95 each. Editorial, Publishing and Sales Offices: 1120 Old Country Road, Plainview, New York 11803. Controlled circulation postage paid at Plainview, NY 11803 and an additional mailing office.

Now you hear it...

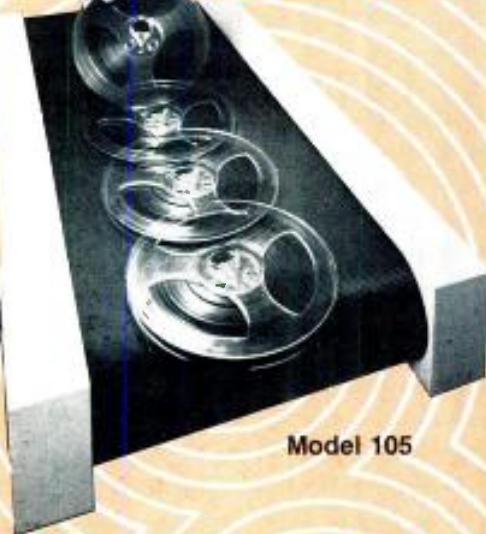

Model 105

Now you don't.

The Garner Audio Tape De-gaussers are truly the most flexible and thorough audio tape erasers available. With them, you can erase cassettes, reels, and cartridges in just four seconds. And, we guarantee that your erasure will meet the most stringent recording standards. It really is a case of "Now you hear it... Now you don't."



GARNER INDUSTRIES, INC.

4200 No. 48th St., Lincoln, Nebraska 68504
Phone (402) 464-5911

There's more to hear...

Just write Garner Industries for more information:

NAME _____
 TITLE/POSITION _____
 COMPANY _____
 ADDRESS _____
 CITY _____ STATE _____ ZIP _____

Circle 43 on Reader Service Card

db Letters

THE KEN POHLMANN FAN CLUB

KEN POHLMANN, MEET SUE BISHOP

TO THE EDITOR:

Mr. Pohlmann's dream of The Audio Computer is a reality! Digital Music Systems markets a general-purpose audio computer as described in your article "The Audioprocessor" in the Theory and Practice column of the July 1982 issue of db.

Our DMX-1010 Computer Sound Processor is a general purpose audio signal processor capable of replacing most of the signal processing units found in recording studios, including delay lines, phasers, flangers, tape echo units, reverb units, graphic and parametric equalizers, compressors and limiters.

The DMX-1010 includes a PDP-11 03-compatible computer as well as a DMX-1000 Signal Processing Computer. The 11 03 provides the user with the hardware necessary to run a wide range of business applications software.

The DMX-1000 is an ultra-fast mini-computer designed specifically for digital audio signal processing applications and can be easily programmed in an intuitive way to perform almost any synthesis or processing function.

We sincerely share Mr. Pohlmann's vision of the future of the recording industry and look forward to the time when an all digital studio will be the norm.

SUE BISHOP
Digital Music Systems, Inc.

SUE BISHOP, MEET RICHARD FACTOR

TO THE EDITOR:

Thank you for printing Ken Pohlmann's article about our SP2016 digital signal processor. For some mysterious reason, however, he seems to have left out the model number and photograph. To repair this omission, I am enclosing a photograph and a few words about the hardware realization of his scheme.

Seriously, his last paragraph ("It's a great idea -why hasn't someone marketed a general-purpose audio computer yet?") is something of a slap at us and the other manufacturers who have manufactured and marketed such devices for quite some time. To be sure, the complete generality that he wishes for isn't here yet, primarily due to the difficulty of software development, but we're damn close.

RICHARD FACTOR
Vice President

Index of Advertisers

Altec Lansing	27
Ampex	Cover II, 16
Auditronics	14
Crescendo	64
Crown	11
Emilar	28
Eventide	34-35
Garner	6
Goldline	63
JBL	7
Klark Teknik	43
Lexicon	Cover III
Linear & Digital Systems	18
Link House	29
Maxell	44
MCI/Sony	21
Modular Audio Products	10
MRL	31
Nagra	22
Orban	9
Otari	25
Panasonic	15
Polyfusion	62
Polyline	18
Quad Eight	8
QSC	49
R Columbia	10
Shure	13
Sound Technology	23
STL	46
Studer	33
Tektronix	63
3M	41
TOA	19, 38-39
Urei	Cover IV
White	8
Yamaha	44

Coming Next Month

• Next month will be our (always popular?) nuts 'n bolts issue. Tom Hay of MCI/Sony tackles the problems associated with studio powering and grounding, we'll take a look at what's new and unusual on the product scene, and also feature important topics that are often overlooked. Of course, all our regular departments and our roster of columnists will be on hand. All this coming in November's db—The Sound Engineering Magazine.

Before you invest in new studio monitors, consider all the angles.

No one has to tell you how important flat frequency response is in a studio monitor. But if you judge a monitor's performance by its on-axis response curve, you're only getting part of the story.

Most conventional monitors tend to narrow their dispersion as frequency increases. So while their on-axis response may be flat, their off-axis response can roll off dramatically, literally locking you into the on-axis "sweet spot." Even worse, drastic changes in the horn's directivity contribute significantly to horn colorations.

Introducing the JBL Bi-Radial Studio Monitors.

At JBL, we've been investigating the relationship between on and off axis frequency response for several years. The result is a new generation of studio monitors that provide flat response over an exceptionally wide range of horizontal and vertical angles. The sweet spot and its traditional restrictions are essentially eliminated.

The key to this improved performance lies in the unique geometry of the monitors' Bi-Radial horn! Developed with the aid of the latest computer design and analysis techniques, the horn provides constant coverage from its crossover point of 1000 Hz to beyond 16 kHz. The Bi-Radial compound flare configuration maintains precise control of the horn's wide 100° x 100° coverage angle.

U. Patent applied for.

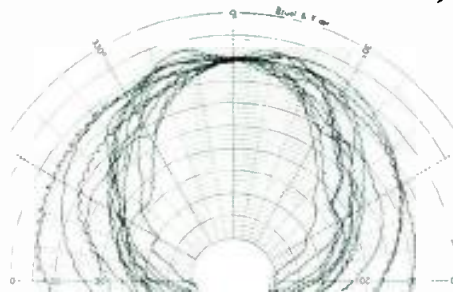

Typical horizontal

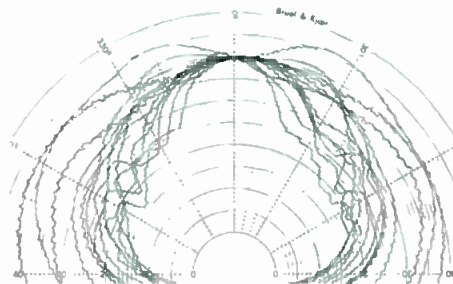

Typical vertical

Polar response comparison of a typical two-way coaxial studio monitor and JBL's new 4430 Bi-Radial studio monitor from 1 kHz to 16 kHz.

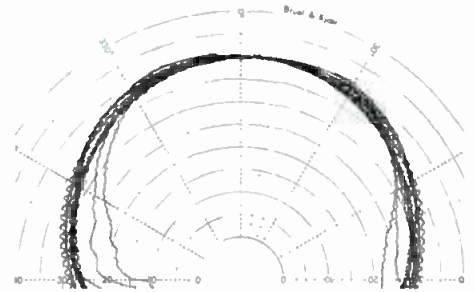

JBL 4430 horizontal

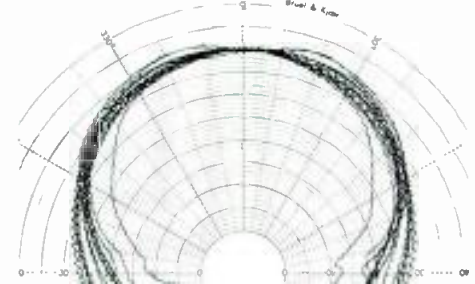

JBL 4430 vertical

And the Bi-Radial horn's performance advantages aren't limited to just beamwidth control. The horn's rapid flare rate, for instance, dramatically reduces second harmonic distortion and its shallow depth allows for optimal acoustic alignment of the drivers. This alignment lets the monitors fall well below the Blauert and Laws criteria for minimum audible time delay discrepancies.

But while the Bi-Radial horn offers outstanding performance, it's only part of the total package. The new monitors also incorporate JBL's most advanced high and low frequency transducers and dividing networks. Working together, these

components provide exceptionally smooth response, high power capacity, extended bandwidth, and extremely low distortion.

Judge For Yourself

Of course, the only way to really judge a studio monitor is to listen for yourself. So before you invest in new monitors, ask your local JBL professional products dealer for a Bi-Radial monitor demonstration. And consider all the angles.

James B. Lansing Sound, Inc.
8500 Balboa Boulevard
P.O. Box 2200
Northridge, California 91329 U.S.A.

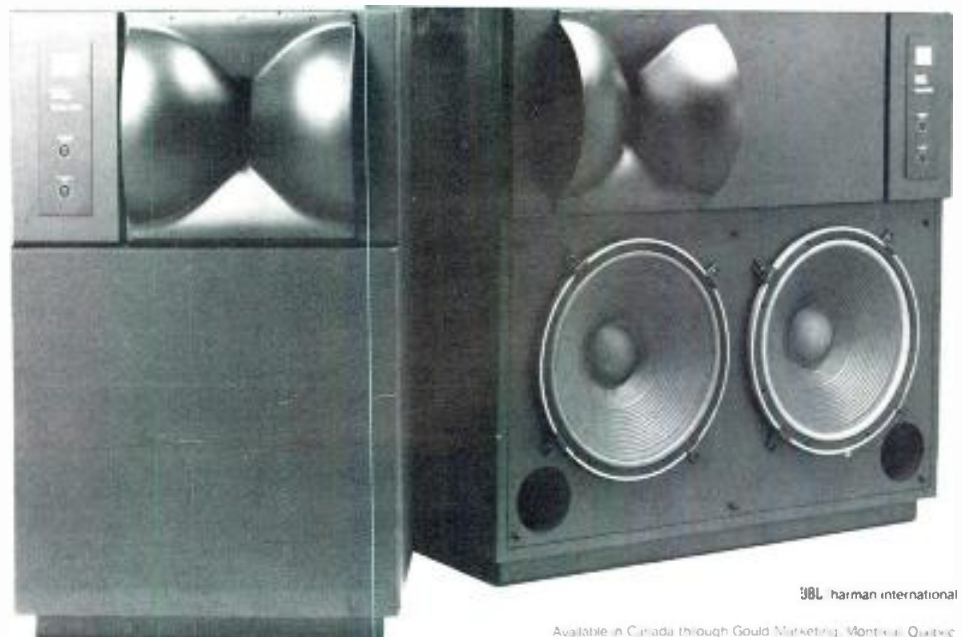

JBL Professional Products Division

JBL harman international

Available in Canada through Gould Marketing, Montreal, Quebec

Circle 31 on Reader Service Card

THE EXPANDABLE SYSTEM 200

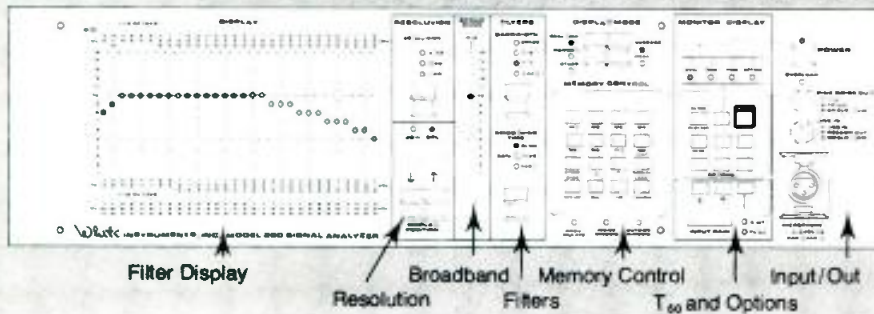

Advanced Microprocessor Controlled Real Time Analyzer.

Featuring:

- Interchangeable Filters
- 45 dB Dynamic Range
- 16 x 31 High Intensity LED Display
- 8 Non-volatile Memories
- 3 Smoothing Time Constants
- Simultaneous Peak and Average Processing
- 0.5 dB Precision
- T₆₀ Measurements
- 3 dB, 2 dB or 1 dB Resolution
- Built-in Pink Noise Generator
- 15 V Microphone Power
- Oscilloscope and Plotter Drive
- Optional Function Generator

All Functions
Microprocessor
Controlled.
Plug-in Options
Available



White

instruments, inc.

P. O. Box 698, Austin, Texas 78767 • 512/892-0752 • TELEX 776409 WHITE INST AUS

Circle 42 on Reader Service Card

20 YEARS IN THE MAKING!



Component Series

For 20 years, **Quad/Eight** has been known for its Academy Technical

Achievement Award winning console designs. Now, all of that performance and engineering excellence have been combined into the new, cost efficient **248 Component Series**.

- As many inputs as you need, and 2, 4 or 8 mixing buses.
- Resetttable, detented 3-band parametric EQ with peaking shelving and 'Q' select.
- Variable Hi-Pass and Lo-Pass filters.
- Full stereo/mono capability.
- Exclusive building block housing system.

Check the features, check the price. **Quad/Eight** does it again.



quad/eight electronics

For the artist in every engineer.

11929 Vose Street

Telephone: (213) 764-1516

North Hollywood, CA 91605

Telex: 662-446 Quadfather LSA

Circle 44 on Reader Service Card

db replies:

Pohlmann is basically lazy, and demands a processor that will do everything. Since the SP2016 only does almost everything, it doesn't qualify. But seriously folks, to see Richard's photograph (of the SP, not of Richard), turns to "Digital Audio Processing" in this issue. In the meantime, Ken's going to try to get his hands on one or both of these toys, to see what they're all about.

C'MON KEN, GROW UP!

On page 8 of the July issue, you allude to Mr. Pohlmann's age. I do hope that wisdom will come with a little more of it, since he does seem to be a quite knowledgeable chap.

I am referring to my old hobby-horse; digital non-quality. Please let Pohlmann know that a straight wire can never be a "program" (July Theory & Practice, page 16). A straight wire is holy — amen — and we have enough trouble finding a really good, uncontaminated one, with no capacitance, no inductance, no magnetic distortion, no atomic aberrations, etc.

So it produces near heart failure to read that it is possible to "...write a straight-wire program." In addition to the more-than-one, badly mangled, noisily routed cable in this "straight wire," we still have A/D and D/A converters working at a 20 kHz sampling rate. We know (and I do have faith in your agreement here) that nothing much musical can come out, with a sampling rate under 200 kHz, plus a filter allowance. And don't forget the input and output filters, which Pohlmann slipped into the previous paragraph, as though they were the most innocent passive devices, whereas they are actually "vices," despite the misleading "de" prefix (again excused on account of youth?).

As to converters, let Mr. Pohlmann invest a little more, instead of suggesting a "budget 12-bit system," and go talk to the people at Analogics about 17 or 18 bits. At least his wire won't be so crooked.

Who wants to hear such audio in practice if the theory is already so sad?

CHRIS LANDMANN

Stuttgart, West Germany

Mr. Pohlmann replies:

Mr. Landmann, I have sinned! Just as countless other lost souls have worked within the confines of an emerging technology, I confess to experimenting with low sampling rates and limited word length prototypes, rather than sitting back to wait for someone else to perfect the 200 kHz system you described.

I beseech you to send me your old hobby-horse, that I might be rescued and carried back to the never-never land of the all-passive system, in the holy domain of Ye Straight Wire. (Amen?)

Truly superior. We'll prove it!



The Orban 424A Gated Compressor/ Limiter/De-Esser

There are lots of production limiters out there. Old favorites. Pretenders to the throne. The competition is fierce. So, when Orban set out to design a new production limiter, we knew it had better be superior.

The result of our research is the "Studio Optimod"—a Gated Compressor/Limiter/De-Esser with versatile controls, simple set-up, and a natural, transparent sound that must be heard to be appreciated.

Try one and A/B it against your current favorite. You'll notice the **sound**—remarkably smooth and natural over a wide range of control settings—even at high compression ratios where apparent loudness and punch are significantly enhanced. It's no accident: The unit is a direct descendent of our super-popular, second-generation OPTIMOD-FM broadcast limiter. So it exploits our years of experience in making an AGC device sound natural on diverse program material without critical re-adjustments. Yet full versatility exists for special effects in production.

A bonus is a smooth, natural de-esser. It's independent of the compressor/limiter section so you can simultaneously compress and de-ess vocal material without compromise. You can even de-ess sibilant vocals which have been mixed with other program.

The icing on the cake is unique gating and "idle gain" functions which prevent unnatural noise-producing gain variations during pauses and abrupt gain changes when the unit is switched in.

Our new Model 424A (dual channel) and 422A (single channel) are destined to become the new industry standards in dynamic range control. Prove it to yourself. Contact your Orban dealer today.

orban

Orban Associates Inc.
645 Bryant Street
San Francisco, CA 94107
(415) 957-1067
Telex: 17-1480

THE FIRST CHOICE YOU MAY NOT HAVE KNOWN YOU HAD!!!

FOR: Audio Op Amps, discrete or hybrid



OR: Rack Mounting Self-contained units



OR: A series of Cards for 3 1/2" Card Frame — "IMPAC"



OR CHOOSE FROM:

- Audio Op Amps ■ MIC Preamps
- Line Amplifiers ■ Equalizers
- Phono & Tape Preamps
- Switcher Cards ■ Oscillators
- Voltage Control Amplifiers
- Distribution Amplifiers
- Monitor Amplifiers
- Compressor Amplifiers
- Console Input Modules
- Bipolar DC Power Supplies
- Mounting Frames & Accessories

OR: Panel Mounting Components for new designs or retrofits

AND MORE TO COME!

Usually in stock or delivery as promised

"MAP a good sound future"

MODULAR AUDIO PRODUCTS

■ A UNIT OF MODULAR DEVICES, INC.

50 Orville Drive ■ Airport International Plaza
Bohemia, New York 11716 ■ 516-567-9620

Circle 46 on Reader Service Card

JUST THE FACTS, PLEASE

TO THE EDITOR:

Your July editorial makes several good points, especially about being in the middle of the spectrum between trade papers and professional journals. That is precisely why I find **db** so useful, between *Audio* on one hand and the *Journal of the Audio Engineering Society* on the other. Keep up the good work.

But the "unemployed" expert is not the only alternative to company people touting their own products. How about more users, or experts in other companies (wow!), or more outside reviewers, or your own staff if possible? Other magazines (*Audio*, *Consumer Reports*, *High Fidelity*, *Stereo Review*, among others) use them, and credibility is enhanced.

"Facts may need supporting evidence; opinions certainly don't." Not so, if an opinion sounds like a conclusion based on facts. "We feel that such-and-such is the most cost-effective material..." doesn't belong in an article in **db** without evidence, let alone proof. Your authors should put up or shut up when they're selling their own product.

As for the publication lag in professional journals, a year or more is atypical, but sadly isn't rare.

Seriously, the more **db** sticks to facts, and limits opinions to those supported by facts, the more it serves its readers. We get enough hype in the mail and elsewhere to welcome a little objectivity.

JOHN K. MAJOR
General Manager
KCMA, Owasso, OK

db replies:

*Well, we still think that there's a place for opinions here in **db**, even if those opinions can't be supported. In fact, supporting evidence is what separates facts from opinions, and there should be room in these pages.*

*But Mr. Major does make a very good point about getting a wider selection of authors published in **db**. We're always looking for new names to add to our list of authors. However, these are hard to come by, as most seem to prefer reading the facts (and opinions) of others, rather than sharing their own.*

Anyone interested in breaking out of this rut, please get in touch with us! Fame (not much) and fortune (even less) can be yours, but first we have to know where you're hiding.

FM Wireless Intercom!

Superb, interference free, intercom up to 1/4 mile! FCC certified and license free. Five channels available. Comfortable; lightweight; only 11 ounces without standard 9 volt batteries. Soft, foam-filled, vinyl ear cushions provide excellent acoustic seal, reducing ambient noise. Interface capability with "hard-wired" systems. VOX accessory available for "Hands Free" operation. Available in single or double ear models. Also hard hat.



- TV & Film cameramen, producers, directors.
- Theatre crews
- Football coaches, assistants, spotters.
- Language translators.
- Manufacturing personnel.
- Tour directors.
- Security personnel

Request Bulletin-4V for TR-50 and other FM wireless models.

INTERCOM MODEL TR-50 \$297.

Manufactured by

R-Columbia Products

Company, Incorporated



2008 St. Johns Ave., Highland Park, IL. 60035
(312) 432-7915 TWX: 910-692-2160



Circle 45 on Reader Service Card

STAR PERFORMERS

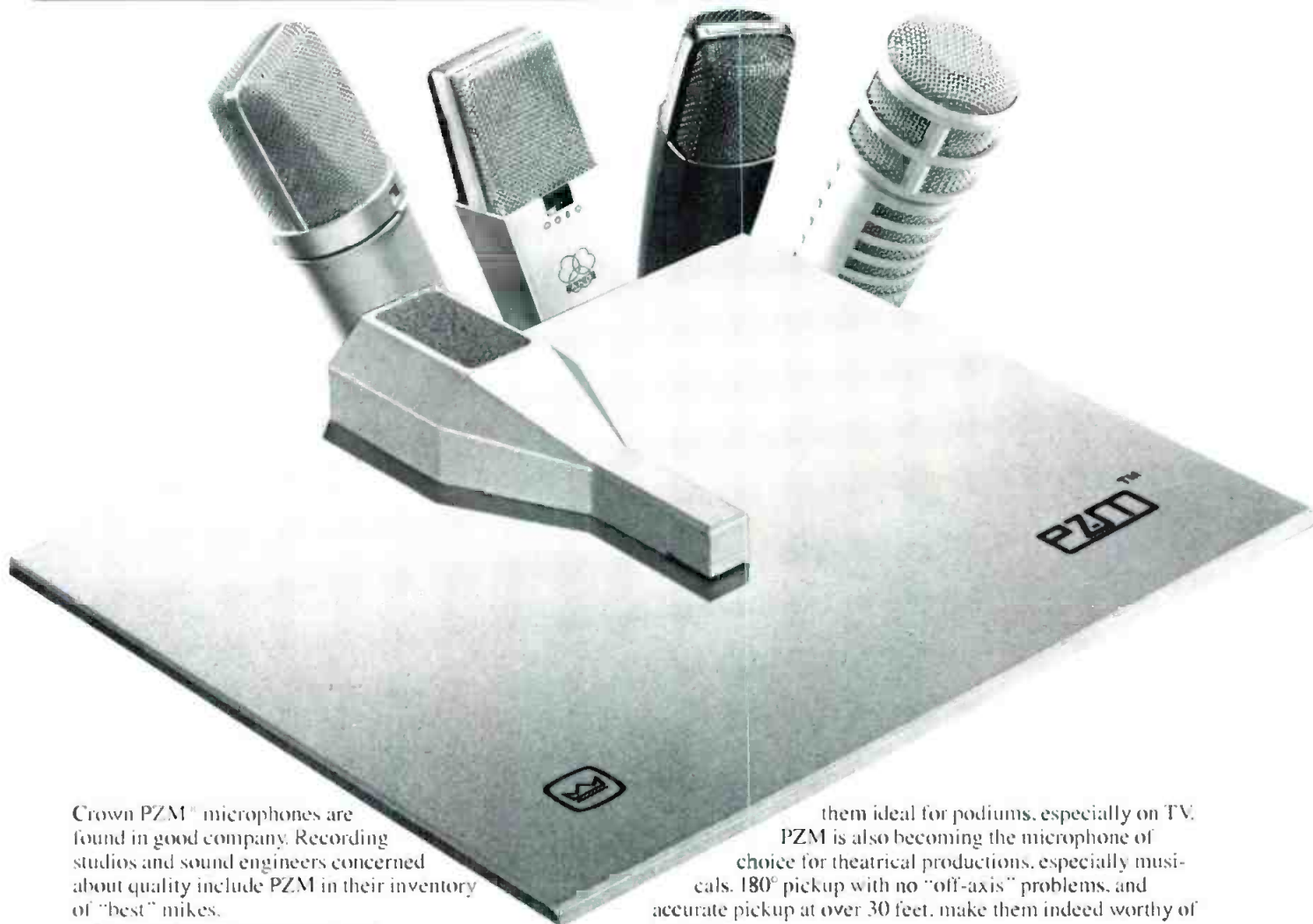

Crown PZM[®] microphones are found in good company. Recording studios and sound engineers concerned about quality include PZM in their inventory of "best" mikes.

There are good reasons for that.

The extraordinary reach and clarity of PZM mikes adds extra dimensions to miking set-ups, and can often simplify the set up. An overhead PZM, plus a ribbon or condenser mike for extra emphasis on the snare, is often all you will need for a drum kit.

PZM can also add quality to the recording. One skeptical symphony orchestra conductor listened to a tape recorded with only two overhead PZM mikes, and joyfully admitted that it was the first time anyone had recorded what he heard on the podium.

The low-profile, "hidden" look of PZM mikes makes

them ideal for podiums, especially on TV. PZM is also becoming the microphone of choice for theatrical productions, especially musicals. 180° pickup with no "off-axis" problems, and accurate pickup at over 30 feet, make them indeed worthy of top billing.

Send for your free copy of the latest issue of PZMemo, the Crown newsletter of PZM ideas. Among other worthwhile items on how and where to use PZM, you'll soon be reading the details of a new, totally redundant clip-on PZM mike. To stay up-to-date with PZM technology, just fill in the blanks below and send this corner of the ad to Crown. It could get you star rating on *your* next performance.

Name _____
 Address _____
 City _____ State _____ Zip _____



...WHEN YOU'RE READY FOR REAL!
 1718 W. Mishawaka Rd., Elkhart, IN 46517, (219) 294-5571

Distributed in Canada by REMCRON ELECTRONICS LTD., Don Mills, Ont. • (416) 441-4007

Circle 32 on Reader Service Card

Digital Filters: Part II

• Most of the audio engineering community learns the art of design in the laboratory. We all remember our first analog filter as a simple resistor-capacitor lowpass filter driven with an oscillator and measured with a meter. The discussions on digital filters have, in contrast, tended to the abstract. Perhaps then, it is time to do a laboratory experiment. Since very few of us have programmable signal processing equipment with the required software development systems, we will choose a programmable calculator as our laboratory tool. Like the signal processor, the calculator can be programmed. The difference is only a matter of speed and input mechanism. Nevertheless, we can build filters with the calculator. This tool also allows us to illustrate the art of programming a signal processor. Any programmable calculator will do for the following examples but the illustrations will be based on the TI-58/59.

EXAMPLE I

The first example will be a ten-point transversal filter as shown in FIGURE 1. The essential elements in this filter are a ten-stage delay system and ten multiplications. We first must consider two aspects of the design problem. How shall we select the coefficients, and how shall we write a program? For the moment, I

will focus on the second of the two questions.

The most important structural aspect of the program design is that for each input point there must be an output point. In other words, for each increment of the time clock (sample), a new input sample must enter the filter, and a new output sample must leave. The inputs are just a sequence of values such as 1, 5, 16, 9, 3, 0, 4, 23, 7, 12, 43, etc. We, the outside world, agree to name these samples in the order that they appear to us, e.g. sample 1, sample 2, etc. Time is not really time in the clock sense, rather it is just a way of keeping track of which output data is connected to which input data. If our calculator had a varying speed of computation, hence a non-uniform time, it would not affect the digital filter. Only A/D and D/A converters have a relationship between sample index and real-world time. That comes from the fact that the sampler has a frequency term expressed in units of sample-index⁻¹ second.

ITERATION

We next note that a given output sample, Y_n (where n is our count index), is a function of 10 input samples: X_n through X_{n-9} . This is true for any n . The program operation which computes Y_1 will be the same as that which computes Y_0 except

that n is changed. This clearly suggests that the program need only be written to compute one output sample; such a program would then be repeated for each additional sample. However, the program does need a way of self modification since the index n must change for each computation. Of course, one could write a purely manual program which computed Y_0 with one set of equations, followed by another program which computed Y_1 with another set of equations, etc. This program would be as long as the number of output samples we would need to compute.

If, however, the program is written in a general way with a free index n , then on each iteration, the index is incremented (increased by 1).

DELAY LINE

The first step in the implementation is the creation of a program segment which computes the delay line. Since a delay line must hold previous values, we need 10 registers for this function. They will hold the previous information. Let us select the group of registers from Reg 10 through Reg 19 for storage. To turn the registers into a delay line, we need to write a program. The most direct form is shown below with the notation RC i , for "Recall the data in register i and place



Now getting the hot story live is as easy as calling home. The SM82.

Sometimes a story breaks so fast there's practically no time to set up lines of communication. Knowing that, Shure has developed a microphone to keep both you and the story well covered.

The Shure SM82 Cardioid Condenser Microphone. It's the only line-level microphone tough enough for the rigors of day to day remote ENG broadcast assignments. And all your crew has to do is just patch it straight into the transmitter connection of the nearest telephone... call your station, and they're home free. Or, it can be connected directly across a dialed-up phone line. No separate amplifiers, limiters, or line-level adapters are necessary.

Just as important, the SM82 is ideal for assignments involving very long cable runs (up to one mile without equalization) typically encountered when covering sporting events, parades, and political rallies.

While electronic news journalists will appreciate the SM82's extended reach and exceptional balance in hand-held situations, you'll love its low mechanical handling noise, rugged construction and reliable operation over a

variety of temperature, humidity and wind conditions.

Its built-in limiter kicks in at 100 dB SPL, preventing overload of the microphone's internal line amplifiers.

The SM82 utilizes an internal battery or it can be externally powered by an optional PS1 power supply or equivalent. For added security, it automatically switches to battery power if its simplex source should ever fail.

If you're in the broadcast operations ENG/ EFP business, you know there are lots of ways to get a live story—even more ways to miss one. Now, with the SM82 on the scene, it is simply a matter of calling home.

For more information on the complete line of professional broadcast products, call or write Shure Brothers Inc., 222

Hartrey Ave.,
Evanston, IL
60204, (312)
866-2555.

SHURE®

THE SOUND OF THE PROFESSIONALS®... WORLDWIDE

Circle 18 on Reader Service Card

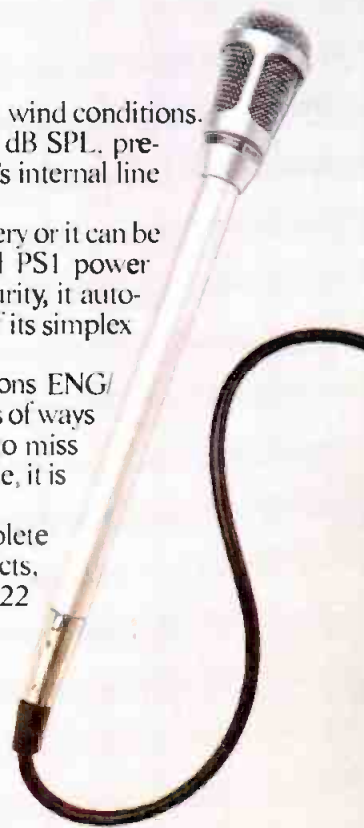

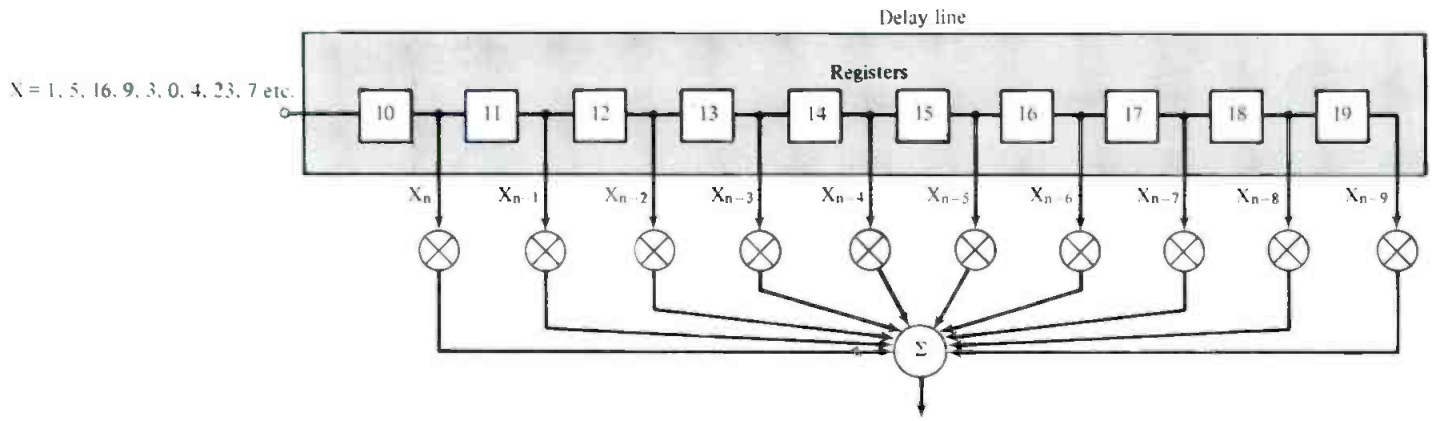

Figure 1. A ten-point transversal filter.

it in the X-register." and ST *i* for "Store the data in the X-register into register *i*." A program might look as follows:

Program	S Comments
RC 18	S transfers data from
ST 19	Reg 18 to Reg 19
RC 17	S transfer data from
ST 18	Reg 17 to Reg 18
RC 16	S transfers data from
ST 17	Reg 16 to Reg 17
RC 15	S transfers data from
ST 16	Reg 15 to Reg 16

RC 14	S transfers data from
ST 15	Reg 14 to Reg 15
RC 13	S transfers data from
ST 14	Reg 13 to Reg 14
RC 12	S transfers data from
ST 13	Reg 12 to Reg 13
RC 11	S transfers data from
ST 12	Reg 11 to Reg 12
RC 10	S transfers data from
ST 11	Reg 10 to Reg 11
(get new data)	S new data to be stored
ST 10	in Reg 10

The sign \$ is being used to indicate a comment. One of the important parts of programming is to keep good comments near the code to help in the debugging and understanding. Just like there is good laboratory practice with analog circuits, there is good laboratory practice with software.

We should also note the step indicated by (get new data) which is a dummy operation. This means that we present the task but do not indicate how we will

Sound quality.

200 Series On-Air Broadcast Control Console

The Audiotronics 200 Series represents the culmination of latest technology applied for broadcast use. Standard features include Penney & Giles linear VCA controlling faders for reliability and precise tracking accuracy even on stereo channels, noiseless hall effect/CMOS on/off switching, local power regulation on every module to prevent mass failure, built-in Control Room Monitoring controls, a comprehensive logic system and headphone amplifier with local equalization. Available in 4 mainframe sizes for up to 24 mono or stereo inputs, a full line of accessories is provided for custom tailoring to individual requirements.

- Monitoring and Communications for Two Studios
- Equalizers
- Compressor/Limiter/Noise Gates
- Remote Controls
- Redundant Powering
- Clock & Timer

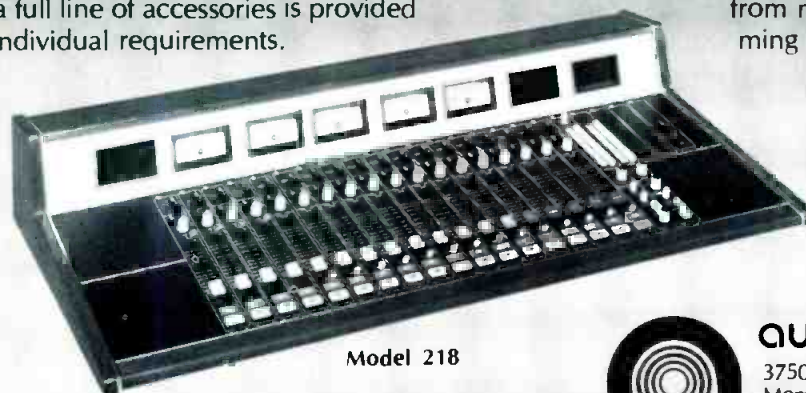

Model 218

Telephone Interface Accessory: Enables complete handling, processing and recording of telephone calls without compromising other console functions.

The 200 Series, the logical choice for on-air operations from music programming to newsrooms.



audiotronics. inc.

3750 Old Getwell Rd.
Memphis, TN 38118 USA
Tel: (901) 362-1350
Telex: 533356

Circle 47 on Reader Service Card



Only technology this advanced can achieve music reproduction this pure. The Technics Digital Cassette Recorder.

No tape hiss. No wow and flutter. Not even head contact distortion. With the digital technology in the Technics SV-P100 Cassette Recorder, they no longer exist.

Utilizing the Pulse Code Modulation (PCM) digital process, the SV-P100 instantaneously translates musical notes into an exact numerical code, stores them on any standard VHS cassette, then "translates" them back into music on playback. Duplicate tapes are exactly the same as the original. Thus, every recording and every copy is a "master."

The revolutionary size of the Technics SV-P100 Cassette Recorder (17"x11"x10") is the result of state-of-the-art semiconductor technology. The built-in videotape transport mechanism brings the convenience normally associated with conventional front-loading cassette decks to a digital application. Tape loading is

completely automatic. And, frequently used controls are conveniently grouped on a slanted panel with LED's to confirm operating status.

Despite its compact size, the SV-P100 Recorder offers performance beyond even professional open-reel decks. Since the digital signal is recorded on the video track, the space usually available for audio can therefore be used for editing "jump" and "search" marks. The unit employs the EIAJ standard for PCM recording. And, in addition, editing and purely digital dubbing are easily accomplished with any videotape deck employing the NTSC format.

The Technics SV-P100 Digital Cassette Recorder is currently available at selected audio dealers. To say that it must be heard to be appreciated is an incredible understatement.

Technics
The science of sound.

Circle 17 on Reader Service Card

Better Than A Guarantee

You only check a guarantee after something goes wrong.

You can check the strip chart in every box of Ampex 2" Grand Master® 456 as our assurance that nothing will.

Which is why we test every reel of 2" Ampex 456 end-to-end and edge-to-edge. The strip chart of the test results tells you that you'll get a rock-solid readout with virtually no tape-induced level

variations from one reel of 456 to another or within a single reel.

No other brand of tape undergoes such rigorous testing. And as a result no other brand offers you the consistency of Ampex Tape. A consistency that lets you forget the tape and concentrate on the job.

AMPEX

Ampex Corporation • One of The Signal Companies 

Ampex Corporation, Magnetic Tape Division
401 Broadway, Redwood City, CA 94063
(415) 367-4463

**4 out of 5 Professionals Master
on Ampex Tape.***



*1981-1982 Billboard Magazine
Brand Usage Survey

Circle 19 on Reader Service Card

YEO "BLESSER"	1.	RUN	5.	RUN	16.	RUN	9.	RUN	7.	RUN	0.	RUN	4.	RUN	23.	RUN	7.	RUN	12.	RUN	43.	RUN	
W2LBLE 4			STO 10		STO 10		STO 10		STO 10		STO 10		STO 10		STO 10		STO 10		STO 10		STO 10		STO 10
RCL 10		RCL 19	RCL 19		RCL 17		RCL 14		RCL 14		RCL 14		RCL 19		RCL 19		RCL 19		RCL 19		RCL 19		RCL 19
0.	0.	0.	0.	0.	0.	0.	0.	0.	0.	0.	0.	0.	0.	0.	0.	0.	0.	0.	1.	0.	0.	0.	0.
RCL 17		RCL 15	RCL 15		RCL 12		RCL 12		RCL 18		RCL 18		RCL 12		RCL 12		RCL 18		RCL 18		RCL 16		RCL 16
0.	0.	0.	0.	0.	0.	0.	0.	0.	0.	0.	0.	0.	0.	0.	0.	0.	1.	0.	0.	0.	5.	0.	16.
STO 14		STO 14	STO 14		STO 14		STO 14		STO 14		STO 14		STO 14		STO 14		STO 14		STO 14		STO 14		STO 14
RCL 17		RCL 17	RCL 17		RCL 17		RCL 17		RCL 17		RCL 17		RCL 17		RCL 17		RCL 17		RCL 17		RCL 17		RCL 17
0.	0.	0.	0.	0.	0.	0.	0.	0.	0.	0.	0.	0.	0.	0.	0.	0.	0.	0.	0.	0.	0.	0.	0.
STO 18		STO 18	STO 18		STO 18		STO 18		STO 18		STO 18		STO 18		STO 18		STO 18		STO 18		STO 18		STO 18
RCL 18		RCL 18	RCL 18		RCL 16		RCL 16		RCL 16		RCL 16		RCL 16		RCL 16		RCL 16		RCL 16		RCL 16		RCL 16
0.	0.	0.	0.	0.	0.	0.	0.	0.	0.	0.	0.	0.	0.	0.	0.	0.	0.	0.	0.	0.	0.	0.	0.
STO 17		STO 17	STO 17		STO 17		STO 17		STO 17		STO 17		STO 17		STO 17		STO 17		STO 17		STO 17		STO 17
RCL 19		RCL 15	RCL 15		RCL 15		RCL 15		RCL 15		RCL 15		RCL 15		RCL 15		RCL 15		RCL 15		RCL 15		RCL 15
0.	0.	0.	0.	0.	0.	0.	0.	0.	0.	0.	0.	0.	0.	0.	0.	0.	0.	0.	0.	0.	0.	0.	0.
STO 16		STO 16	STO 16		STO 16		STO 16		STO 16		STO 16		STO 16		STO 16		STO 16		STO 16		STO 16		STO 16
RCL 14		RCL 14	RCL 14		RCL 14		RCL 14		RCL 14		RCL 14		RCL 14		RCL 14		RCL 14		RCL 14		RCL 14		RCL 14
0.	0.	0.	0.	0.	0.	0.	0.	0.	0.	0.	0.	0.	0.	0.	0.	0.	0.	0.	0.	0.	0.	0.	0.
STO 15		STO 15	STO 15		STO 15		STO 15		STO 15		STO 15		STO 15		STO 15		STO 15		STO 15		STO 15		STO 15
RCL 17		RCL 13	RCL 13		RCL 13		RCL 13		RCL 13		RCL 13		RCL 13		RCL 13		RCL 13		RCL 13		RCL 13		RCL 13
0.	0.	0.	0.	0.	0.	0.	0.	0.	0.	0.	0.	0.	0.	0.	0.	0.	0.	0.	0.	0.	0.	0.	0.
STO 14		STO 14	STO 14		STO 14		STO 14		STO 14		STO 14		STO 14		STO 14		STO 14		STO 14		STO 14		STO 14
RCL 12		RCL 12	RCL 12		RCL 12		RCL 12		RCL 12		RCL 12		RCL 12		RCL 12		RCL 12		RCL 12		RCL 12		RCL 12
0.	0.	0.	0.	0.	0.	0.	0.	0.	0.	0.	0.	0.	0.	0.	0.	0.	0.	0.	0.	0.	0.	0.	0.
STO 17		STO 17	STO 13		STO 13		STO 12		STO 17		STO 13		STO 17		STO 13		STO 17		STO 13		STO 13		STO 13
RCL 11		RCL 11	RCL 11		RCL 11		RCL 11		RCL 11		RCL 11		RCL 11		RCL 11		RCL 11		RCL 11		RCL 11		RCL 11
0.	0.	0.	0.	0.	0.	0.	0.	0.	0.	0.	0.	0.	0.	0.	0.	0.	0.	0.	0.	0.	0.	0.	0.
STO 12		STO 12	STO 12		STO 12		STO 12		STO 12		STO 12		STO 12		STO 12		STO 12		STO 12		STO 12		STO 12
RCL 18		RCL 18	RCL 18		RCL 18		RCL 18		RCL 18		RCL 18		RCL 18		RCL 18		RCL 18		RCL 18		RCL 18		RCL 18
0.	0.	0.	0.	0.	0.	0.	0.	0.	0.	0.	0.	0.	0.	0.	0.	0.	0.	0.	0.	0.	0.	0.	0.
STO 11		STO 11	STO 11		STO 11		STO 11		STO 11		STO 11		STO 11		STO 11		STO 11		STO 11		STO 11		STO 11
STOP		STOP	STOP		STOP		STOP		STOP		STOP		STOP		STOP		STOP		STOP		STOP		STOP

Figure 2. Simulating a delay line with a programmable calculator. In the first column, it is seen that all ten registers (10-19) contain zeroes. In the second column, a 1 is entered and stored in register 10 (RUN STO 10). At the bottom of the

column, the 1 is recalled from register 10 and stored in register 11 (RCL 10 STO 11). In the next column, a 5 is entered, the sequence repeats. The 1 moves up to register 12, and the 5 moves into register 11. By the time the next-to-last

column is reached, the 1 has travelled the length of the "delay line," and appears at the output (RCL 19). By the final column, the 1 is no longer in the delay line.

implement that task. It is being postponed until we deal with the mechanism for entering new data. If we wish to test this program segment, we might actually enter the data by hand. This brings us to the subject of testing. It is much more difficult to test a complete program than to test it in segments. To test this program, we might add the following.

The beginning location of the program must be specified if we wish to start there. Let us assume that the start is address 000. Then, we add a final step at the very end: GOTO 000. The program will now loop. To get new data, we might replace the (get new data) with an R S which stands for RUN, STOP. When this step is active, the program will stop to allow us to enter the new data. We then press the R S key to continue. Try running the program. At the tenth iteration, i.e. the tenth data input, the first input point will at last appear at the output of Reg 19; after 11 cycles, the second input point will appear there.

The software program is analogous to a hardware implementation using shift registers. Each of the storage registers corresponds to one element in the shift register. At each cycle, the data is moved along to the next element. In the hardware implementation, all of the data can move at the same time on one edge of the clock. In the software version, each activity becomes a separate step. Hence, we must unload Reg 18 before it is loaded. It is for this reason that the program is written starting from the higher registers (longer delays) rather than from the lower registers (shorter delays). If we had written in the wrong way, we would have found that out during the debug activity.

It is interesting to note that the program is analogous to wiring hardware. By changing the program, we can make the function completely different. The ten registers were originally unconstrained, but our program wired them together as a shift register.

ALTERNATE OPERATIONS

With a little more experience, we'll find that the program can be improved by taking advantage of another program operation called EX *i* (Exchange the X-register with Reg *i*). This operation does two things simultaneously. Data is swapped between two places on one step. Now our program can be re-written to run somewhat faster and to use about half of the memory space to do the same function. The new program is as follows:

```

Program      $ Comment
(get new data)
EX 10      $ new data stored in Reg 10,
           $ old data transferred to
           $ X-Reg
EX 11      $ X-Reg data from Reg 10
           $ stored in Reg 11, old Reg 11
           $ data transferred to X-Reg.
EX 12      $ same but Reg 12
EX 13      $ same but Reg 13
EX 14      $ same but Reg 14
EX 15      $ same but Reg 15
EX 16      $ same but Reg 16
EX 17      $ same but Reg 17
EX 18      $ same but Reg 18
EX 19      $ same but Reg 19

```

This new program is very much like the old program in terms of the algorithm, but the coding has been changed. Functionally, we will see the same results in each register with both programs. In

other words, coding changes usually do not change the results as observed from outside the program. At the end of an iteration, all the data is the same in the ten registers. However, the new coding is more efficient in terms of memory space and running time.

Both programs have the property that increasing the number of taps for linger filters will result in a longer program. The data-line size is proportional to program speed and program space. With a long enough delay line, the calculator will run out of storage capacity and we would have to buy a more powerful processor (calculator). Alternatively, we might consider the case where speed was an issue. Assume that we wish to make the program faster, but that we don't have enough space. In this case we might invent another algorithm to achieve the same result in less program steps.

RUNNING SPEED

Running speed is usually proportional to the number of instructions which need to be executed to perform the desired function. Memory space is the size of the program. In our examples, the two programs are both proportional to the delay line length. An analysis of the program shows that the program is burdened by the fact that *n* pieces of data must be moved for each input data point. Consider an algorithm in which the input data is parked in the appropriate register and we just change the definitions of the registers with each iteration. In the previous algorithms, each register had a unique name, e.g. Reg 19 was the data after ten delays. Our new approach will keep a separate register for the "name"

Noise Suppression & Power Protection



Model PS-1

The PS-1 is a power line conditioning unit designed to protect audio equipment from high voltage transients and RI interference. Three neon lamps indicate relative phasing of the line, neutral and ground connections. A latching relay helps to avoid amp speaker damage due to power up transients generated after a temporary loss of power. Ask your local music dealer for more details.



**Linear & Digital
Systems, Inc.**

46 Marco Lane, Centerville, OH
45459 (513) 439-1758

Circle 34 on Reader Service Card

Audio Tape for professionals

REEL TO REEL TAPE
Ampex, 3M. All grades.
On reels or hubs.

CASSETTES, C-10-C-90
With Agfa, TDK tape.

LEADER & SPLICING TAPE

EMPTY REELS & BOXES
All widths, sizes.

**Competitive!
Shipped from Stock!**

Ask for our recording supplies catalog.

Poly Corp. 312/298-5300
1233 Rand Rd. • Des Plaines, IL 60016

Circle 28 on Reader Service Card

information. We call this information a *pointer*. New input data is placed in the register specified by the pointer.

Let us define Reg 00 as the pointer register. We now consider the algorithm to be, "Place the input data in the next-highest register compared to the previous iteration." For example, if the last data was placed in Reg 14, place the new data in Reg 15. The pointer Reg 00 keeps track of where the data is to be placed. The first input data is placed in Reg 10, the next in Reg 11, the next in Reg 12, etc. The problem comes when we reach Reg 19 (the end of our selected register group). The algorithm is then given a special case: when placing data into Reg 19, change the pointer to 10 instead of 20. The sequence continues. Another way of looking at the algorithm is to say that the ten registers are arranged in a ring. Reg 11 follows Reg 10, Reg 12 follows Reg 11, Reg 19 follows Reg 18, and Reg 10 follows Reg 19. This algorithm has a very interesting advantage over the previous algorithm. Each new entering data point must be stored in a selected place and the pointer indicating the place must be computed. Previously, all the data had to be moved. A 30-element delay line would have required 30 data transfers in the old approach but only requires 1 in the new!

Such a program is easy to write because the calculator has a function called IND (indirect). The operation SI IND 0 does not mean store the data in Reg 0. The instruction means store the data in the registers "named" by Reg 0. If the information in Reg 0 was 14, then SI IND 0 would place the data into Reg 14. This program step does all of the data-transfer work for the entire program. However, we must now write a program segment which computes the pointer values.

We wish the pointer to increase in value once per iteration but to reset to 10 when it reaches 19. The increment function is relatively easy to implement. The direct approach would be:

```
RC 0    S get old value of pointer
        S placed in x-register
+       S add
1       S 1
=       S compute sum
St 0    S replace result in Reg 0
```

More compact would be the program which uses the SUM *i* function since this can add directly into a register without bringing the data in the X-register. The program becomes:

```
1       S increment value
SUM 0   S add directly to Reg 0.
```

A still more compact program segment takes advantage of a special built-in increment function. This would be:

```
OP 20   S directly increment Reg 0 by 1
```

Again we see that there are many ways to code an algorithm, but the choices depend on the characteristics of the calculator hardware.

We are now left only with the complex

task of the reset activity. This requires a test to determine if the pointer is at 19 and if it is we must reset it to 10. A test can be explicit or implicit. The explicit test might be the following:

```
RC 0    S recall pointer from Reg 0
x-t     S place data in t-register
19      S data comparison refer-
        ence
If X >= t
    GOTO B S test: if X is greater than
            or equal to t then goto B,
            otherwise continue
10      S reset value (executed
            only if test failed)
SI 0    S reset Reg 0 (executed
            only if test failed)
Label B S place to enter from test
        above
OP 20   S normal increment func-
        tion
```

This program contains a "branch test." The IF...GOTO means that a segment of the code will be skipped if the test is true. In our case, the skipped code contains the reset function which places 10 in the pointer register. Normally, the pointer is incremented. All of this sounds good, but this kind of program code is error-prone. In fact, the code we have written contains several errors which we would find if we tested it. The increment function always runs, even when the reset is active. Hence, the reset will result in 11, not 10, in the pointer. A fix could easily be added such as changing the 10 (reset value) to 9. This takes into account the increment function.

Another example of this kind of program using the implicit reset function is shown below. This code uses the "modulo" function.

```
RC 0    S get pointer from Reg 0
-       S subtract 10, hence shifting
        point range from 0 to 9
10      S result of range shift
÷       S divide by ten creating range
        of 0 to 0.9
10      S result
FRACT   S strip off integer part leaving
        fractional remainder
×       S turn fraction back into
        0 to 9 range
=       S result
+       S add 10 to shift range
        back to 10 to 19
10      S result
=       S result
SI 0    S new pointer
```

By subtracting 10 and dividing by 10, the FRACT function strips off the 1 if the original pointer had been 20. Thus, 20 maps to 10.

NEXT MONTH

The discussion on building a digital filter with a calculator will continue next month. That article will not be comprehensible without this one. It would be a good idea to put this issue away until next month.

Toa speaker components give more power to more professionals.



1. HSH-651 Sectoral Horn 2. HRH-851 Radial Horn (large size) 3. HRH-651 Radial Horn (middle size) 4. HRH-311 Radial Horn (small size) 5. HLS-3806 Low-frequency Speaker 6. HLS-3006 Low-frequency Speaker 7. HLS-3010 Low-frequency Speaker 8. HLS-3812 Low-frequency Speaker 9. HNW-351 Dividing Network (3-way) 10. HNW-251 Dividing Network (2-way) 11. HPF-151-8 High Pass Filter 12. HFD-651 High Frequency Compression Driver 13. HFD-352 High Frequency Compression Driver 14. HT-371 Horn Tweeter

an ultra-smoothly operating high-pass filter and crossover network.

The professionals at Toa put more into their speaker components so the pros who use them have the best possible audio.

Toa speaker components are the product of years of Toa experience with sound reinforcing equipment and with the dedicated professionals who use them. To ensure that these experts have all the sound quality, efficiency and durability they've come to expect in speaker components, we've designed ours to do more. Toa offers 15 & 12 inch woofers with an edge-wound copper ribbon voice coil and high flux density ferrite magnet; radial and sectoral design horns with 90° horizontal and 40° vertical dispersion; highly efficient compression driver units with smooth reproduction characteristics (power handling of 20W and 60W continuous pink noise); a tweeter with a newly developed exponential oval horn to ensure wide dispersion. And to make sure all these units work together at their best, Toa also provides

Toa is also looking for professional-level dealership enquiries and OEM arrangements to help meet growing demand for the full line of high quality Toa sound products. Contact Toa for more information.



TOA ELECTRIC CO., LTD.

ADDRESS: 2-1 TAKAMATSU-CHO, TAKARAZUKA, HYOGO 665, JAPAN
MAILING ADDRESS: P.O. BOX 702, KOBE PORT, JAPAN PHONE: 0797-71-2211
CABLE: TOAELECTRIC TAKARAZUKA TELEX: J64150 TOA PA

• For further information, contact your nearest Toa office:

WEST GERMANY: Toa Electric Deutschland G.m.b.H., Kaiser Wilhelm Str. 89, 2000 Hamburg 36, West Germany
PHONE: 040-345742/344213
U.S.A.: Toa Electronics, Inc., 480 Carlton Court, South San Francisco, Ca. 94080, U.S.A. PHONE: 415-588-2538

Sound Fields, Part 1

• The influence of sound fields on the performance of sound reinforcement systems is a profound one. These fields determine the attenuation of sound with distance, and hence the loudness of reinforced sound at a particular distance. They also determine the nature of reflections and reverberation and, indirectly, the system's degree of speech intelligibility. In this month's column, we will deal with steady-state sound fields, both in and out of doors.

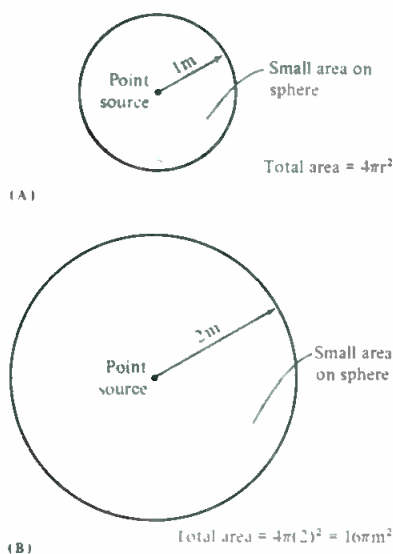

Figure 1. The inverse-square law relationship.

SOUND FIELDS OUT OF DOORS: INVERSE-SQUARE LAW

In a typical outdoor environment, there are few reflections, and the sound field is called a *free field*, or *direct field*. If we measure sound pressure as we move away from a point source of sound in a free field, we will observe that it falls off almost exactly 6 dB per doubling of distance. The reason for this is shown in FIGURE 1. At A, we have a point source located at the center of an imaginary sphere of one meter radius, and we want to measure the intensity (watts m⁻²) of sound at some small area on the surface of that sphere. Now, let us move on to the situation shown at B. Here, the same

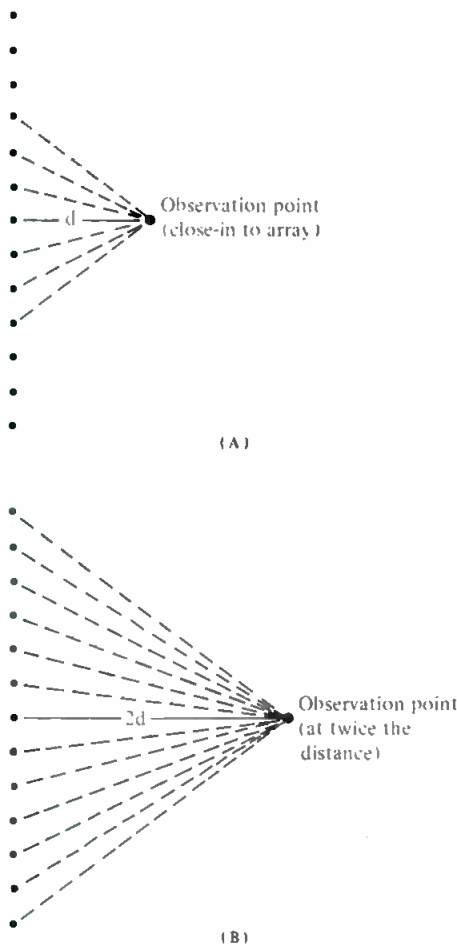

Figure 2. The inverse relationship of the line array.

point source of sound is placed at the center of a sphere of two meters radius. The area of this larger sphere is *four-times* that of the smaller sphere, and the intensity of sound observed at the *same* small area will be *one-fourth* that observed with the smaller sphere. A power ratio of 1/4 represents a level difference of 6 dB, and thus for each doubling of distance from the point source, we will observe a drop of 6 dB. This relationship is known as the *inverse-square law*, and it can be summed up in the following equation:

$$\text{Level difference} = 10 \log(d/d_0) = 20 \log(d/d_0)$$

In this equation, *d* is the distance at which we make our measurement, and *d₀* is the reference distance. The nomograph of FIGURE 1C provides a convenient way to read inverse-square relationships directly.

Most loudspeaker components used in sound reinforcement systems, if observed at normal operating distances of, say, 5 meters or greater, behave substantially as point sources, and the inverse-square law can be used to estimate sound pressure levels over normal operating distances. A typical case follows:

A horn driver combination has a sensitivity rating of 115 dB, 1 watt at 1 meter. What SPL will be observed at a distance of 23 meters in the free field with a power input of one watt?

$$\begin{aligned} \text{Level difference} &= 20 \log(23/1) = 27 \text{ dB, and therefore,} \\ 115 - 27 &= 88 \text{ dB-SPL.} \end{aligned}$$

Referring to the nomograph of FIGURE 1C, we can read the value of 27 dB directly above the number 23. We should note that this nomograph can be used for determining relative levels using any consistent set of dimensions, meters or feet.

We do not normally have the occasion to observe the fall-off of sound from a long extended line array of sound sources, since these are rarely used in sound reinforcement work. However, if we were to measure the sound pressure level at, say 100 meters from a busy freeway, and then move out to a distance of 200 meters, we would observe that the level would have fallen only 3 dB. The reason for this is shown in FIGURE 2. At A, we are relatively close-in to the line array (of freeway traffic), and only a few of the individual radiators (that is, vehicles) influences the sound pressure level. At B, farther away from the line array, more elements in the array influence the observed sound pressure. The rule governing this is known as the *inverse law*, and it is given below:

$$\text{Level difference} = 10 \log(d/d_0)$$

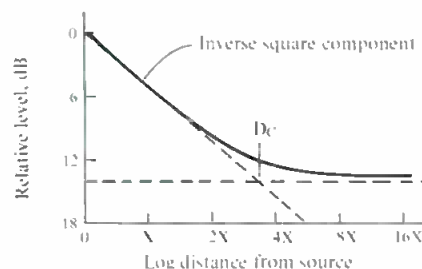

Figure 3. Attenuation of sound indoors.



The original is
still the greatest.

JH-110B High Profile Cabinet

JH-110BX Variable Profile Cabinet

We at MCI are very flattered that the JH-110 Series has become the most imitated professional recorder in the world, especially in view of some simple facts. Only MCI has been making professional recorders for professionals, and consoles to match for 25 years. Only MCI has risen above "Hi-Fi" hype to publish complete performance curves on all its magnetic recording instruments for any professional to read and understand. Only MCI's transformerless design can deliver square wave response second to none in the industry. And only MCI sells its products through a small, carefully selected network of dealers who stand behind every product they sell. So if you're considering a new professional tape recorder in any format, take a close look at MCI. And discover the original.

MCI[®]

A Division of Sony Corporation of America

1400 W. Commercial Blvd., Ft. Lauderdale, FL 33309 USA, Telephone (305) 491-0825. Telex 514362 MCI FTL

Circle 30 on Reader Service Card

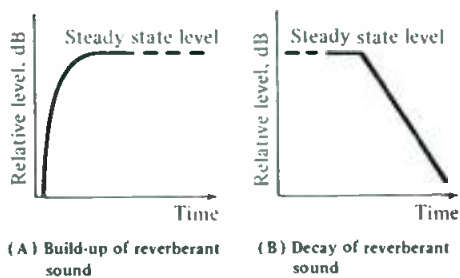

Figure 4. Build-up and decay of reverberant sound.

As before, d is the measuring distance, and d_0 is the reference distance. The nomograph of FIGURE 1C can be used here as well—if we remember to halve the level we read in dB.

INDOOR SOUND FIELDS

Let us assume that we are in a fairly reverberant room. If we walk slowly away from a sound source, we will hear the sound level drop off rapidly at first, and then taper off to a fairly constant value, beyond which it will not drop further. This is depicted in FIGURE 3. Note that there is a direct field component, which dominates close to the source, and a reverberant field component, which dominates at greater distances.

The reverberant field represents *energy storage* in the room. It builds up when a source of sound is turned on, and it decays for some time after the sound source is turned off. When viewed in terms of decibels, the growth and decay curves

are as shown in FIGURE 4A and 4B. We normally measure the decay rate as *reverberation time*, the time required for the reverberant field to decay 60 dB after the source of sound has been turned off.

If we know a few acoustical parameters of the room, we can determine the reverberation time as well as the steady-state level in the room for a given transducer operating at some given input power. The equation we are most familiar with for determining reverberation time is the Eyring equation:

$$T_{60} = \frac{0.15 V}{-S \ln(1 - \bar{\alpha})} \quad (1)$$

In this equation, V is the room volume in cubic meters, S the total surface area in square meters, and $\bar{\alpha}$ is the average absorption coefficient of all the surfaces (walls, floor and ceiling) in the room. (For example, if $\bar{\alpha} = 0.2$, this means that 0.8, or 80 percent, of the sound energy striking a surface will be reflected, and 20 percent will be absorbed and dissipated as heat. Using English units, the preceding equation is written:

$$T_{60} = \frac{0.049 V}{-S \ln(1 - \bar{\alpha})} \quad (2)$$

If we can measure, or estimate, the reverberation time of a room, we can arrive at the average absorption coefficient by rearranging Equation (1):

$$\bar{\alpha} = 1 - \exp(-.15 V / ST) \quad (3)$$

In this equation, V and S are the measured volume and surface area, respectively, in cubic meters and square meters, and T is the observed reverberation time. Knowing $\bar{\alpha}$, we can move on to a new quantity, R , the *room constant*:

$$R = \frac{S \bar{\alpha}}{1 - \bar{\alpha}} \quad (4)$$

If S is measured in square meters, then R will have the units of square meters. Likewise, if S is measured in square feet, then R will have the units of square feet.

We are now in a position to determine the actual reverberant field level in the room. Referring to FIGURE 3, the shape of the attenuation curve is given by the following equation:

$$\text{pressure} = \rho_0 c W \left[\frac{Q}{4 \pi x^2} + \frac{4}{R} \right] \quad (5)$$

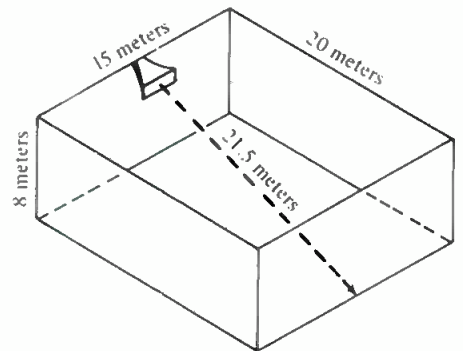

Figure 5. An indoor sound reinforcement system.

Nothing Compares to The Quality and Feel of The Nagra T-Audio Studio/Remote Recorder

- Twin Capstan, Servo-controlled tape transport with interhead tension sensing.
- Detachable, individual control keyboard for full remote capabilities.
- Interchangeable head assembly.
- Keyboard selection of any one of four pre-set modes for speed, tape type and standard.
- Four speed operation — 30ips, 15ips, 7½ips, 3¾ips, plus variable playback speed control.
- High speed copying capabilities — ten m/s spooling.
- Servo-control editing with built-in cutter.
- AC/DC operation... even off your car battery.
- Matrix display for "record" and "output" modes.
- Power, phase-lock and tape tension warning display.
- 15¼" L x 15½" W x 9¾" H, compact; 44 lbs lightweight.



Test curves and complete specifications on request.

NAGRA MAGNETIC RECORDERS, INC.

A Subsidiary of Nagra Kudetski, Switzerland



East Coast
19 West 44th St. Room 715
New York, NY 10036
(212) 840-0999

West Coast
1147 N. Vine St.
Hollywood, CA 90038
(213) 469-6391

In Canada:
ArriNagra, Inc.
6467 Northam
Mississauga, Ont. L4V 1J2
(416) 677-4033

See us at Booth 210
AES, Anaheim

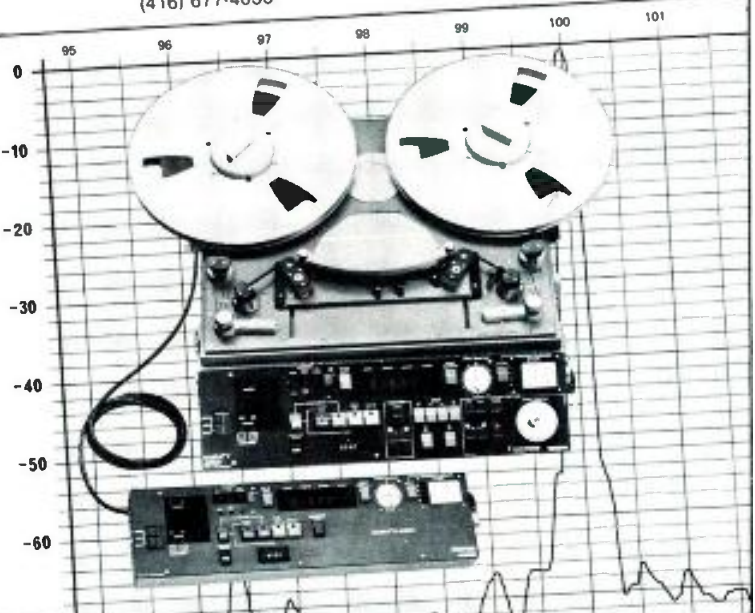

THE PROFESSIONAL'S CHOICE

ST 1710A Professional Distortion Analyzer

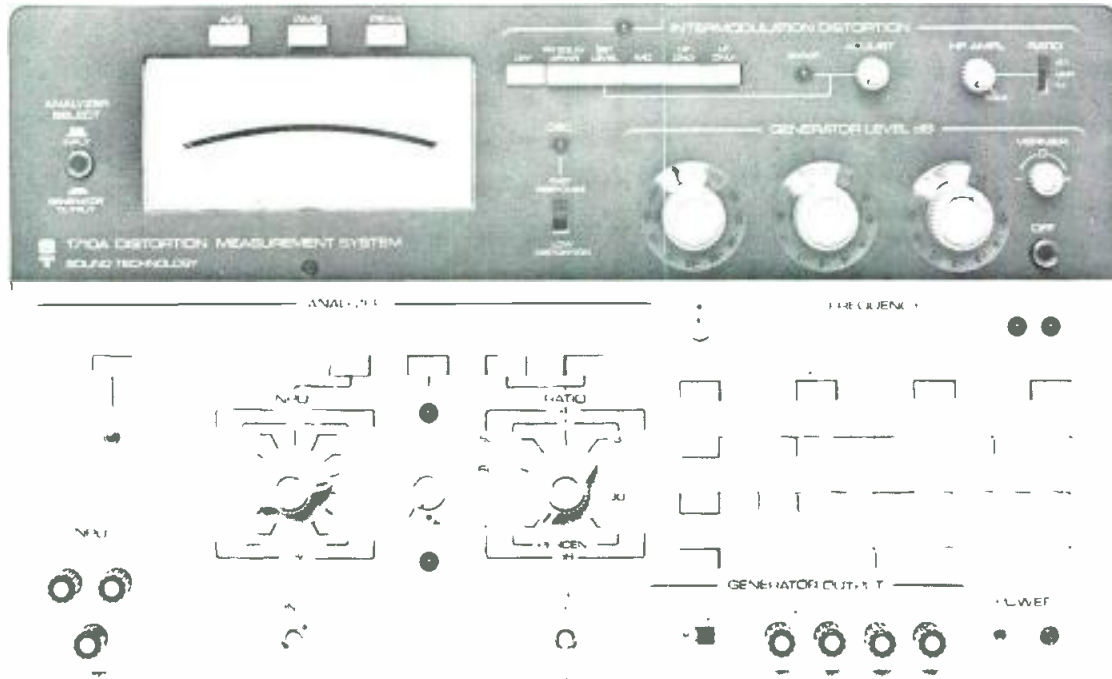

The Sound Technology 1710A Professional Distortion Measurement System has established itself as the industry standard of the professional audio market.

Why?

The Sound Technology 1710A combines a pure sine wave generator, a high resolution total harmonic distortion analyzer, an accurate AC level meter and an intermodulation distortion analyzer in one instrument.

The Ultra Low Distortion oscillator outputs a pure sine wave signal from 10 Hz to 110 kHz with the output level being adjustable from +26 dBm down to -89.9 dBm in 0.1 dBm steps. That is a clean signal even at 24.8 μ V.

Completely floating and balanced signal source circuits in the 1710 allow you to drive virtually any circuit — whether balanced, unbalanced, off ground, or whatever, with no loss of level and no ground loops.

RF Shielding built into and around the 1710 makes it immune to RFI. Referring to the 1710's 10 volt/meter RF rejection, one engineer labeled it 'Bulletproof'.

**S SOUND
T TECHNOLOGY**

1400 DELL AVENUE
CAMPBELL, CALIFORNIA 95008
Telephone: (408) 378-6540
Telex: 357445

Nulling is automatic; punch up your test frequency and the 1710 simultaneously nulls the fundamental frequency.

Selectable RMS, Average and Peak responding meter circuits allow you to measure to accepted standards quickly.

With the 1710 you can measure THD down to .002% in less than five seconds, IMD down to .001%, Voltage from 100 μ V to 100 V full scale, measure Power in dBm and measure 100 dB Signal-to-Noise ratios.

Push a button and reject hum and high frequency noise with the built in 18 dB/octave filters (400 Hz, 30 kHz and 80 kHz). Flip a switch to select either a 150 or 600 ohm source impedance. Terminate the output signal for fast S/N measurements with the push of a button. To check the 1710's output level, punch in the analyzer select button; it throws the output signal right into the analyzer, no cable switching, fast and easy.

See for yourself why the Sound Technology 1710A is the standard for the Audio Professional. Contact us for full information and the name of your factory representative.

AES BOOTH #207

©Sound Technology 1982

This rather-complicated equation gives the value of pressure in newtons meter⁻² for any value of x . H is the acoustical power, and $\rho_0 c$ is the characteristic acoustical impedance of air. Q is a new quantity, the *directivity factor* of the radiator. The directivity factor is the ratio of sound intensity measured along a given axis of a radiator at a given distance, compared to the intensity observed at the same distance when the same acoustical power is radiated omnidirectionally. It is a measure of how directional a device is, or how much "throw" it has.

The first term inside the parentheses of Equation (5) represents the direct field component, inversely proportional to x , and the second term represents the steady-state reverberant field level. If we equate the two terms and solve for x , we will determine the point along the x -axis where

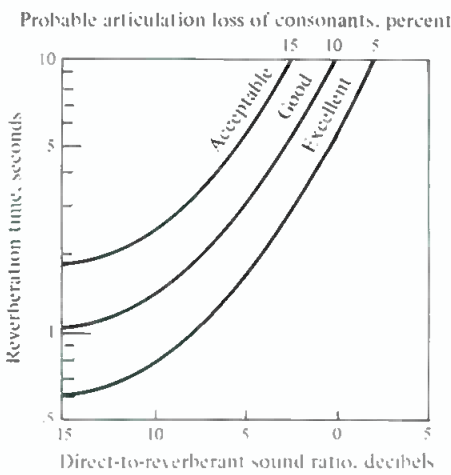
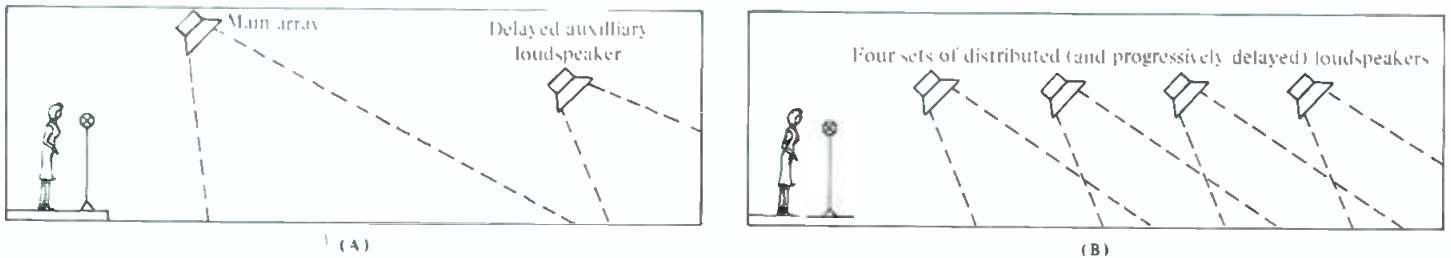

Figure 6. Probable intelligibility as a function of reverberation time and direct-to-reverberant sound ratio. (Chart developed from data published by V.M.A. Peutz in the *Journal of the Audio Engineering Society*, Vol. 19, December, 1971).

We know from our previous calculations that the reverberant level at any point in the room is 96 dB-SPL. Therefore, the direct-to-reverberant ratio is $86 - 96 = -10$ dB.

INTELLIGIBILITY CRITERIA

Will this system be intelligible at the back of the room? In order to make an estimate of this, we refer to the data of FIGURE 6. These curves are adapted from the work of Peutz (see reference) and give an estimate of the likely intelligibility of a sound reinforcement system. Peutz's criteria are based on the fact that the excessive overhang of reverberation creates a kind of "noise" below the direct speech level heard by the listener. The longer the reverberation time, the higher the direct-to-reverberant ratio must be in order to preserve a given degree of intelligibility.

both fields are equal. This point is known as *critical distance*, D_c .

$$\begin{aligned} Q/4\pi x^2 &= 4/R \\ x^2 &= QR/16\pi \\ x &= \sqrt{QR/16\pi} = .14\sqrt{QR} \quad (6) \end{aligned}$$

Equation (6) is independent of units; if R is measured in meter², then D_c will be in meters. The same holds for feet.

Now let's pick a particular radiator, place it in a particular room, and then determine the reverberant field level. A typical 90 degree by 40 degree horn/driver combination will have a sensitivity rating of 113 dB, 1 watt at 1 meter, and a Q of about 12. Let us place the horn/driver combination in a room which has a reverberation time of 2 seconds and whose dimensions are:

- length = 20 meters,
- width = 15 meters,
- height = 8 meters.

First we calculate the volume and surface area:

$$\begin{aligned} V &= 2400 \text{ meters}^3 \\ S &= 1160 \text{ meters}^2. \end{aligned}$$

Now, using Equations (3) and (4):

$$\begin{aligned} \bar{\alpha} &= 0.15, \text{ and} \\ R &= 208 \text{ meters}^2 \end{aligned}$$

Using Equation (6) to find D_c :

$$D_c = 7 \text{ meters.}$$

Figure 7. Two approaches to distributed systems. (A) a central array with auxiliary loudspeaker, and (B) progressively delayed small loudspeakers located on each side of the auditorium.

If we power the horn/driver with one watt, we know that the value of the direct and reverberant fields will be equal at a distance of 7 meters, thus:

$$\begin{aligned} \text{Level at 7 meters} &= 113 - 20 \log(7/1), \\ &= 113 - 17 = 96 \text{ dB.} \end{aligned}$$

The actual level at D_c , along the major axis of the horn, will be the *sum* of both fields, or 3 dB above 96 dB.

DETERMINING THE DIRECT-TO-REVERBERANT RATIO

Through a simple set of calculations, we have determined the reverberant field for a given transducer, room, and power input. By comparing the fixed reverberant field level with the inverse-square component anywhere in the room, we can determine the ratio of the two, an important concept in estimating the intelligibility of reinforced speech.

In the case we are studying here, the horn has as its largest throw a distance of about 21.5 meters, as shown in FIGURE 5. By inverse-square law, the direct field level at 21.5 meters will be:

$$\begin{aligned} \text{Level} &= \\ &113 - 20 \log(21.5/1) = 86 \text{ dB-SPL.} \end{aligned}$$

The curves of FIGURE 6 indicate that the system we have just analyzed will have "acceptable-to-good" articulation.

But what if the room had been considerably more reverberant, and the system had not met the criteria? Then the options open to the designer would be:

1. Increase R by adding absorption to the room. This has the effect of lowering the reverberant sound level in the room as well as shortening the reverberation time.

2. Determine whether or not a horn with narrower coverage angles can work. The higher value of directivity factor will result in a lower reverberant field level.

3. A final alternative is to go to some kind of distributed system, one in which all or part of the auditorium would be covered by a multiplicity of small loudspeakers fairly close to the listeners and driven at fairly low levels. This approach maintains a higher direct-to-reverberant ratio, while providing a relatively low reverberant level in the room. Two possible approaches to this are shown in FIGURE 7.

Next month, we will continue our study of sound fields, noting the characteristics of highly absorptive and semi-enclosed spaces, as well as the time varying aspects of sound fields. ■

REFERENCE

Peutz, V. M. A., Articulation Loss of Consonants as a Criteria for Speech Transmission in a Room, *J. Audio Engineering Society*, Vol. 19, No. 11, p. 915 (1971).

**IF YOU MAKE
LOTS OF THESE,**

**WE'LL
SHOW YOU HOW
TO MAKE LOTS OF THIS.**

If you're not already in the high-quality, high-speed cassette duplicating business, maybe you should be.

It's a high-profit business when you do it for somebody else. Or, if you buy cassettes in large quantities, it's probably about time you seriously considered bringing your needs in-house. Either way, you can't lose.

If you chose the right equipment to get the job done.

Like Otari's proven DP-1010 Series system. It's a 16:1, high-speed professional duplicator. The DP-1010 is CRO² capable for the growing premium cassette market too. It's also the kind of investment that won't trap you into a corner. That's because it's expandable. With the basic system pictured here, you can pump out more than 600 high-quality recordings per day. For under \$16,000.00. One Master Reproducer, one Slave and one high-speed winder for custom length loading (winder, Model DP-2700 not pictured).



Model DP-1310
Master Reproducer &
Model DP-1510 Slave Recorder

Need more? Easy. Add up to nine more slaves, an optional loop bin, and you can be up to 6,000 cassettes per day. Or—anywhere in between, if you have to take things a little slower. The best news yet is that you don't need an army of technicians to run the Otari DP-1010.

Fill in the blanks and send this coupon to Mike Pappas at Otari. He'll tell you how to get into the business of duplicating premium quality cassettes.

Please rush me full technical information on the following:

- DP-1010, 16:1 High-Speed Duplicators
- DP-7000, 64:1 High-Speed Duplicators
- DP-2700, High-Speed Winder/Loader
- V-O, Video Loading Equipment

Name _____ Title _____

Firm _____

Address _____

State _____ Zip _____

Tel () _____ (optional) Please contact me immediately.

OTARI The New Workhorse

Otari Corporation, Industrial Products Division
2 Davis Drive, Belmont, California 94002
(415) 592-8311 TWX 910-376-4890

© 1982 Otari Corp.

Circle 15 on Reader Service Card

The Sal-Mar Construction

• Once or twice a year I have the pleasure, and challenge, of reacquainting myself with one of the world's great music-generating systems. It has more instruments than a symphony orchestra, but fewer players than a flute duo. It doesn't have any input transducers, but has 28 output ones. It is three meters high, two meters wide, one meter deep, weighs 1000 kilograms, but can be played only by lightly touching it with your fingertips. It is perhaps the most sophisticated real-time music composing and performing instrument ever built. Chances are, you've never heard of it.

Once or twice a year I drop my toothbrush and logic analyzer into my suitcase and fly to Urbana, Illinois. My friend and mentor Salvatore Martirano, professor of music composition at the University of Illinois, meets me at the airport and we go out to his house, and into his studio. We spend three or four days there checking the system, wading through the incredible intricacies of the hybrid circuitry. When all is readied we dismantle it, put it on a truck or plane, and accompany it to Chicago, Stony Brook, Houston, Brussels, Tokyo, or wherever. We spend another two days reassembling and checking the instrument, and preparing the performing space. Then at some point, Sal draws up a chair for a couple of hours of improvisation on the Sal-Mar Construction.

In 1971, while I was still trying to figure out zener breakdown, Martirano assembled a team of electrical and computer engineers including Borovec, Divilbiss, Franco, and Noggle, and proposed the construction of a new type of synthesizer. The machine was to be unlike any previous electronic musical instrument in that it was to produce a completely synonymous machine musical logical output. Rather than using analog circuitry or a computer to generate sounds, the processors in this instrument were actually to be *played* in real time. The instrument was to offer a vast collection of musical parameter possibilities—and ways to algorithmically choose and influence those and future possibilities—thus determining both course and

destination of the algorithm. In effect, both the composition and the instrument upon which it is performed are created in real time. The instrument's conception was intrinsically based on its ability to simultaneously accomplish composition and performance, that is, improvisation. By definition, musical improvisation involves inventing possibilities and then realizing them acoustically for the listener. The possibilities must also be uniquely selected. That is, they must be reconciled compositionally with respect to the history of the past selections in order to present a musically interesting result. To offset the complexity of those simultaneous tasks, and to permit a new level of real-time music composing, the Sal-Mar was devised.

A SINGLE REAL-TIME EVENT

Traditionally, music-making has been a lengthy process distributed in time and among various individuals. In conventional instrument building, the designer is faced only with the problem of choosing the instrument's characteristics—such as timbre and loudness, and the kind of mechanical actions needed to develop duration, crescendi, tempi, etc. Meanwhile, the traditional composer has created a score, compositionally working out pleasing structures which can be performed upon the instrument, given its limitations—such as range and the technique required. The performer, in turn, takes the completed instrument, masters its technique, and applies it to the finished score. Finally, in the case of an orchestra, a collection of such players, under direction, performs the score upon their instruments. The Sal-Mar is an attempt to consolidate these processes into a single real-time event. Since it is played improvisationally, the roles of composer and performer are consolidated, and since the nature of the instrument is always uniquely devised, the role of the instrument builder is also consolidated. Finally, since the Sal-Mar has 100 output channels, the orchestra itself is consolidated. Thus, the entire music-making process has been designed

into a single system, for execution by a single composer designer performer, in real time.

The secret to that accomplishment is not so much the invention of a marvelous machine, as it is a carefully considered system which facilitates the human operator's ability to successfully deal with the complexity of the situation. The tasks to be divided between man and machine were defined such that the human operator was given the task of choosing possibilities in sound parameter and algorithm, and compositionally employing them. The machine was given the job of creating most of the possibilities, and devising most of the musical characteristics such as timbre, pitch, duration, etc.

To take advantage of the most desirable properties of analog and digital design, a hybrid design was executed in which analog circuitry is generally used for sound generation, and digital circuitry is used for musical parameter control. All of the analog sound modules are programmable devices, which depend on digital information for their control. That information takes the form of control sequences which consist of a series of binary words which are addressed and delivered at the appropriate time, in real time. To achieve an efficient control system, that information flow is, once again, divided according to the tasks involved. The machine is able to generate its own control sequences from feedback shift registers and memories. A programmable, rather than fixed, feedback function is achieved through a modulo-two adder with programmable patterns of active inputs. A broad range of sequences, many of useful musical value, offers a collection of compositional elements. But in a given musical context, only a small number of the available parameters might be useful. Thus information filtering must be accomplished to constrain the available information within an appropriate limit. Programmable window detectors are used to create this scheme to scale and thus best utilize available information for a given context. A central unit creates the

THE BEST-DRESSED RACKS GO BY THE BOOK.

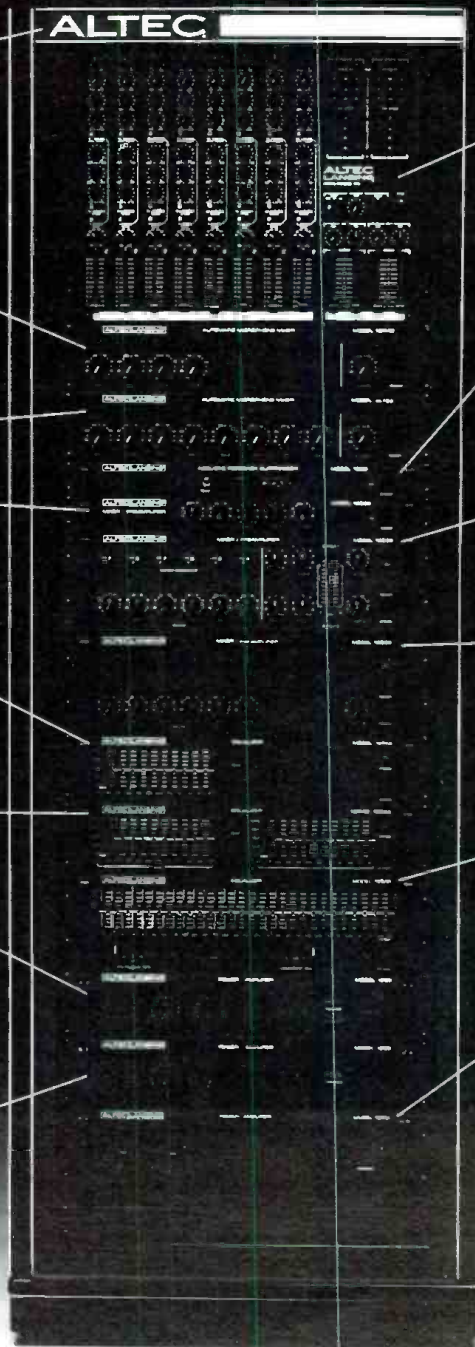

ALTEC LANSING— the choice of sound professionals for over 50 years.

1674—4-Channel Automatic Microphone Mixer shares gain among individual mics in multi-mic set-up. Increases gain of in-use mics, lowers others for hands-off mixing.

1678—8-Channel Automatic Microphone Mixer with same features as 1674.

1689—2-Channel Mono/Stereo Mixer/Preamplifier. Includes phantom power, mic and line level inputs.

1651—Single Channel Graphic Equalizer with 10 1-octave, active filter sections. Up to ± 12 dB boost/cut with center detented slide controls.

1652—Stereo Graphic Equalizer with same features as 1651 for each channel.

1268—Stereo Power Amplifier. 60+ watts/channel into 8 ohms 20 to 20kHz at less than .03% THD. 200 watts/mono. Optional line transformers for balanced input. Computer protection of amp and load.

1269—Stereo Power Amplifier. 120+ watts/channel, 400/mono, with same performance and features as 1268.

1690—8-Channel Stereo Mixer/Preamplifier for sound reinforcement, recording and mixdown. Linking connectors allow coupling additional 1690s for expanded versatility.

1620—Acoustic Feedback Suppressor automatically detects feedback oscillations, lowers gain and adjusts system to optimum level for hands-off feedback control.

1692—6 in, 2 out Mixer/Preamplifier. Each input with volume, gain, high pass, phantom power and optional remote volume control.

1699—6 in, 2 out Mixer/Preamplifier/Mixer Extender. "Link out" feature provides 12 independent channels when paired with 1692.

1653— $\frac{1}{3}$ -Octave Graphic Equalizer with 29 active filter sections, 25 to 16kHz. 18 dB/octave continuously variable high and low pass filters.

1270—Stereo Power Amplifier. 400+ watts/channel into 4 ohms, 800 into 8 ohms/mono. Computer circuits protect amp and speakers. Fan cooled. VI limiter helps the 1270 handle the toughest loads.

Altec Lansing's Black Rack Book—featuring Altec's new line of power amps, mixers, equalizers and related electronics. Precision-matched for optimum sound power and control, Altec's components work together for increased system efficiency and performance. For the ultimate in custom-tailored sound for your system, send the coupon to:



Black Rack Book
P.O. Box 3113
Anaheim, CA 92803

Name _____
Address _____
City, State, Zip _____
Occupation _____

Circle 14 on Reader Service Card

DB

© Altec Corporation

control sequences and the windows through which they are biased. The sequences are circulated through memory, and addressed by programmable modulus counters for dynamic parameter control.

MACROSTRUCTURAL AND MICROSTRUCTURAL

The human operator is also able to generate control sequences, but only on the level at which he may efficiently participate. To distinguish that, control sequences are classified as macrostructural or microstructural. Microstructural sequences affect individual characteristics of the sound modules themselves. Since this real-time instrument designing occurs too fast for human participation, the microstructural sequences are all derived from the system's collection generators. Macrostructural sequences are used to deterministically manipulate the microstructural sequence generators, which are designed to be externally programmable. Since microstructural sequences occur at much slower rates, the human operator is given the option of creating his own macrostructural sequences. Thus, through a single gesture, the operator is able to initiate complex and very rapid control patterns.

In the automatic mode, the system's macrostructural sequence generators are used to control the microstructural sequence generators. The choice of

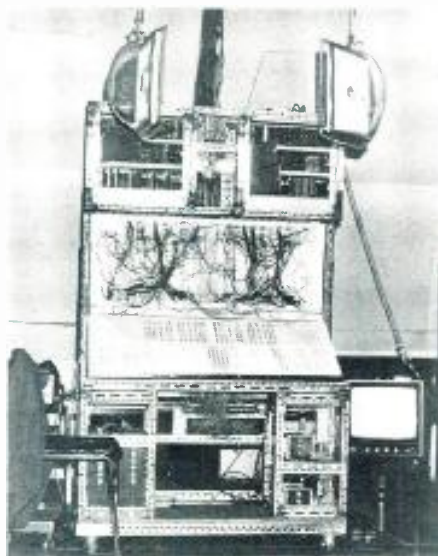

Sal-Mar Construction Concert at SUNY at Stony Brook, L.I.

manual or automatic operation in this aspect of the machine's structuring is made by the human operator with one-bit sequences to information steering devices comprised of two-to-one data selectors. To permit one more level of control, the macrostructural sequence generators are also programmable, by the human operator. The design concept, integral to the system, of sequences controlling other sequences, is an example of how the system's nature corresponds to the nature of composed music. Through designed structures such as these, the burden of detail can be lifted from the human operator. The division of tasks, and the hierarchy of structured control, successfully solves the problem of the multi-level complexity inherent in music. The system could be likened to that of a conductor and an orchestra, in that the operator is mainly concerned with macroscopically guiding and deflecting an event which occurs both because of him, and in spite of him.

THE ORCHESTRAS

The music generating part of the system is organized into four orchestras, each accessible to the human operator through a single demultiplexed multiplexed touch panel. The decision to employ four orchestras instead of a larger single orchestra permits cooperation and conflict, and hierarchical interplay between the four independent forces. The control panel contains all the control and data indicators necessary to set up and enter operator input information to one orchestra, and display system input information and system status of one orchestra. As 291 touch switches and indicators are needed, the panel is time-shared between the four orchestras to save cost and complexity.

Four digital oscillators are used to clock the four orchestras to determine basic tempi, and can run autonomously, or according to a slaving rule devised by Martirano to configure the orchestras in

hierarchical time relationships. The four clocks are slaved in an ascending hierarchy such that lower numbered clocks can control the higher ones, but not vice-versa. As with the control sequences, the choice of slaving or not slaving a given clock to one of the other eligible clocks can be decided automatically, or manually. The operator, however, decides on the mode of operation.

The orchestras are comprised of eight voice modules. Each voice module consists of: a frequency synthesis circuit to manipulate pitches from 12 to 20 equal divisions per octave; a dual digital waveshape generator to determine timbres; a mixer modulator and programmable filter to control tonal properties, and an attenuator/locator for spatial control. Voice modules are interactive such that under automatic or manual command, one voice can modulate others' parameters. For example, one waveshape may modulate the envelope duration, pitch, and spatiality of three others. Two of the orchestras also contain a percussion ensemble of 16 instruments each. These instruments consist of dedicated hardware, a trigger/envelope driver and a phase-shift oscillator, to produce percussive, damped oscillations.

An output system is shared among the four orchestras. It employs four output channels through which each orchestra controls the directionality of its sounds by programming its distribution among the four channels. Programmable artificial reverberation varies the depth of sounds. The output system also employs 24 loudspeakers, each with 4 input channels (one for each orchestra) to create 96 more output channels. In performance, the 24 loudspeakers are suspended above the audience, and the human operator uses a representative array on the touch panel to devise traffic patterns through the loudspeaker array. Thus, sounds from every orchestra can be routed to varying combinations of the 24 loudspeakers to create literal sound travel through the performance space.

That is a cursory look at an amazing musical instrument and musical experiment, the culmination of a two year collaboration between a team of engineers and a composer. In a time of off-the-shelf thinking, it is heartening to observe this superior way of approaching questions—the way in which a problem is uniquely explored and individually answered. In a time of commercial answers, it is good to see a truly artistic response. What is the nature of composition and performance? How may technology be married to art? What kinds of interactive roles can exist between men and machines? The Sal-Mar is an answer to those questions. And what does the answer sound like? I sincerely hope that one day you will have the chance to hear it for yourself. ■

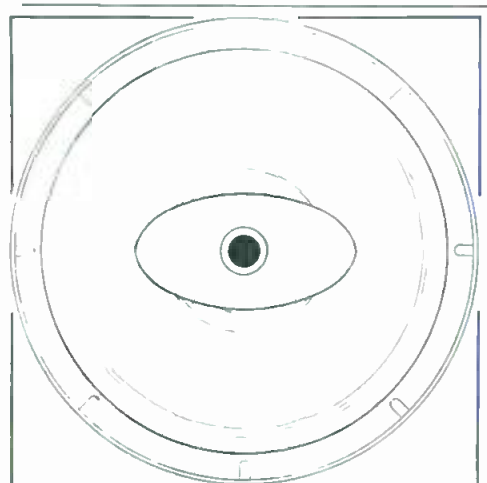

EHL-15 CO-AX
200 Watts
103 dB M/W
Double Spider
15 Inch

EMILAR

For complete information call
714-632-8500 — 800-854-7181

EMILAR CORPORATION
1365 N. McCan St.
Anaheim, CA 92806

OUT NOW!!

The latest editions of two important and well respected reference books on sound and television broadcasting and engineering. AN ABSOLUTE MUST FOR THE BUSY PROFESSIONAL.

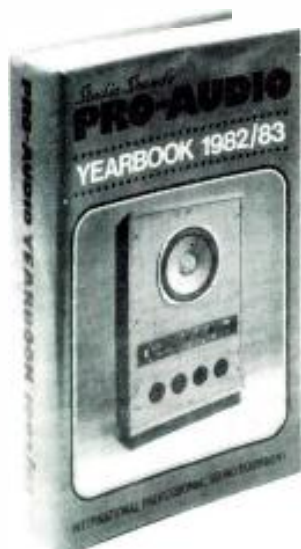

PRO AUDIO YEARBOOK 1982/83

138mm x 216mm
660 Pages (Approx)
ISBN 0 900524 98 7
Casebound

Over 600 Black &
White Photographs
ISSN 0260-8537

The **PRO-AUDIO YEARBOOK** is an annual guide to products and services for engineers and technicians operating in the world of professional recording and sound broadcasting around the world. Published in hardback and containing over 650 pages, it contains sections covering every conceivable pro-audio requirement. In addition to the many product sections, there are sections covering Engineering and Consultancy Services, Jargon and Journals, Computer Services and Training, and an important section providing full details of Mains Power Supplies in almost 200 countries.

The 1982/3 edition of the **PRO-AUDIO YEARBOOK** has been completely revised and updated, providing even better coverage of the ever expanding pro-audio market.

VIDEO YEARBOOK 1982/83

138mm x 216mm
660 Pages (Approx)
ISBN 0 7137-1144-2
Casebound

Over 600 Black &
White Photographs
ISSN 0140-2277

To anyone engaged in the business of communicating via television, the **INTERNATIONAL VIDEO YEARBOOK** should need no introduction.

This lavish publication has, over the years, become an institution to the buyer of television equipment or services around the world.

The first part contains over 70 separate sections covering every conceivable type of video equipment ranging from cameras, through Monitors, Effects, Editing to Video Recorders. In addition there are new sections covering Airborne Video, Satellite Stations, Antenna and Masts, Video Hard Copy and Portable Audio Mixers, and of course the renowned International Television Standards section.

The second part of the book contains the indexes, cross referenced to the product sections, and giving full addresses, phone and telex numbers and principal contact for over 2,500 companies in the video and related industries around the world.

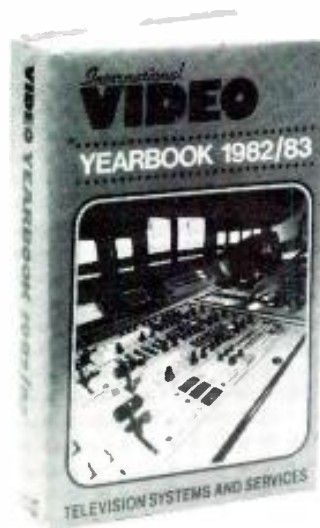

Please fill in the coupon and return with remittance to:
Sagamore Publishing Co, 1120 Old Country Road, Plainview, New York 11803, USA.
(In NY State, add applicable sales tax)

PLEASE SEND

copies Pro-Audio Yearbook 1982/83 @ \$54.00 each

copies Video Yearbook 1982/83 @ \$54.00 each

(All Prices include Surface Delivery Please add \$7.00 per book For Air Mail)

Name
Company Name
Address

Phone Number
Signed

Please charge my Access American Express Diners Club Mastercard Visa card number (please delete as appropriate) Card holders address must be used

Card No. Please send by Air Parcel (see above) I enclose a cheque for

Please return the completed order form enclosing your full remittance (including delivery) or giving your credit card number, to:

Sagamore Publishing Co, 1120 Old Country Road, Plainview, New York 11803, USA.
(In NY State, add applicable sales tax)



A New Approach To Post-Production Audio For Video

• Most of the post-production audio systems that I have seen used for video work in recent years traced their origins to the world of film. The very adaptation of sprocket-hole synchronization to magnetic audio tape, which is still quite commonly used even in post-production audio for video work, comes from the world of 16mm and 35mm film.

Recently, I received a call from an old friend of mine, Gerald Kornbluth, whom I knew from the days when I used to do the tutorial narration for A/V presentations for audio equipment manufacturing clients. Jerry serves as an engineer and principal at A&J Recording Studios, which he helped found in 1971 after spending several years as an engineer at Gotham Recording, also in New York. His call to me this time had nothing to do with A&J, however.

For nearly 15 years now, Kornbluth has been collaborating with Irving Robbin, a fully-trained composer and Emmy award winner who also operates a successful music production firm, Aeolus Productions Inc., with extensive credits in film and television. The diverse backgrounds of both men led to an audio-for-video post-production approach that was not limited either by "Production" or "Engineering."

Together, these two men have formed a new company, ATC Research Inc. The company's product is a revolutionary, broadcast cartridge-based music and effects insertion system that is already in use for "live-on-tape" programs on two of the three major networks. Design decisions for their new system, I found out, were made with a combination of experience that developed from many years on both sides of the production desk. After several years of research, development, and refinement, the first system was put into operation at A&J Recording's New York studio.

HOW THE SYSTEM WORKS

Jerry gave me a practical demonstration of the ATC Research System during my visit to his studio a few weeks ago. Basically, it's a system for selecting and mixing music, sound effects, and voice-over components in a film, videotape, or any other production format that can be synchronized to SMPTE or other time code or frame count. The system uses a computer-controlled bank of broadcast cartridge tape players in conjunction with dual-track and multi-track audio tape recorders. Among the many capabilities of the system is the ability to instantly select, change, combine or insert any audio component at will. Repetitive start accuracy of the system is to within 1/10th of one frame. With the system you can instantly change the time that an event is initiated. Up to 999 separate events (audio component starts) can be programmed. The system allows you to instantly insert or delete additional audio cues, to synchronize all of the audio components when desired and to rehearse from any point in the planned production. Automatic or manual operation of all functions is possible at any point and in any combination. It's compatible with NAB standards (so that cartridges produced elsewhere can be utilized) and with most standard audio sweetening system components.

SYSTEM BUILDING BLOCKS

At least three increasingly elaborate versions of the system are envisioned by ATC Research, Inc. The simplest one is a manually operated system for the insertion into a video or film production of single-source audio components such as voice-over segments, music or sound effects, including the ability for selective access to three components of the system. These are the ATC Cartridge Pro-

grammer, a specially modified Cartridge Recorder-Player, and the ATC Selective Access Controller with remote controls. The selective access controller is especially interesting and a key building block in any of the systems. It is this device which allows narration segments to be encoded onto a single high-quality broadcast type cartridge directly from a rough-cut, 1/4-inch studio tape or leadered tape recorded at any standard speed. The device can then call up any desired segment of the program for instant replay, during rehearsal, audition, or retakes during the mix.

In a second, more flexible manually operated system, a total of five specially modified cartridge players are added, along with a remote control console for the cartridge machines, a cartridge machine bridge cabinet and an ATC cartridge winding accessory. These additions, along with an audio and video package to be described shortly, permit the operator to insert multiple sources of audio components such as voice-over segments, music or sound effects into a video production. The system also



Jerry Kornbluth at work on the ATC Research System.

provides the ability for selective access to these components.

The third, and more elaborate of the systems is a completely programmable computer controlled system. This system is SMPTE time code based and allows for frame-accurate insertion of all audio components, with permanent storage of the insertion program for later re-use, if required. The system, when used along with an audio and video package described below, allows the user to do fully automatic frame-accurate post production and mixing of an audio track for a videotape. In addition to the elements described earlier for the second manual system, this computerized system also includes a computer package with dual disc drives, the necessary software program and printer as well as an AIC Machine Controller and Routing Interface.

THE AUDIO AND VIDEO PACKAGES

The audio package supplied with either of the last-described two systems include an 8-in 4-out mixer, a monitor speaker and amplifier, a 2-track audio tape recorder ($\frac{1}{4}$ -inch) with noise reduction, an 8-track audio tape recorder ($\frac{1}{2}$ -inch) with noise reduction, a cabling and patch bay and a synchronizer (for the moment, a BIX Shadow type). The video package offered with these two systems consists of a JVC 5500 video player, a JVC 6600 video recorder (modified by AIC for this application), a video monitor, an SMPTE Generator Reader and the necessary cabling.

A TYPICAL POST-PRODUCTION SESSION

I asked Jerry to outline the steps that might take place in a post-production project using this system. He described a typical session as running through the following steps:

First, the client would prepare and edit a videotape of the material to which post-

production sound was to be added. This tape would be edited strictly from the video point of view. The next step might be to record a "scratch track" and perhaps finalize the script's timing. The client might then decide, with the operator of the AIC system that 11 pieces of music are needed, for example. The required sound effects would also be decided upon and recorded in the studio. As an auditioning procedure, the audio material might now be recorded in rough form on open-reel, against $\frac{1}{4}$ -inch video. The main narration might also be recorded at this time and might undergo a rough cut to take out dead spots, etc. The next step, and the one that brings the AIC System into play, would be to develop an edit-decision list. Next, the entire list of music spots, sound effects, etc. would be prepared for transferring to the carts. Jerry estimated that in the example cited, this might take only about $\frac{1}{4}$ of an hour with his system, 20 minutes or so is all that would be needed to program-in the edit decisions. Carts can be programmed manually, if the second system described is used, or they can be programmed completely electronically.

As I watched Jerry actually go through a demonstration of the system, using a recent Minolta Camera commercial that he had done, I was amazed at the accuracy with which he was able to cue spots on the multiple carts. He explained that the carts had been recorded not only with the cueing tones which bring the tape to an exact point for subsequent start up, but also had slow-down tones recorded somewhat ahead of the cue point so that the tape would not overshoot the correct cue spots.

As for the time-code synchronization aspects of the system, Jerry told me that the system is ultimately going to special *vertical* interval time code rather than the more conventional longitudinal time code. That is, instead of laying down the

SMPTE time code on the longitudinal-running tape tracks of the videotape, the code would be applied between vertical video frames. The advantage of this approach is that valid time code can be read even when in the still-frame or freeze-frame mode of the video picture, since there is still relative tape-to-head motion under those conditions. When SMPTE time code is recorded on a longitudinal track, it is, of course, not available when in the freeze-frame mode since the tape is then motionless relative to the stationary audio-type tape heads.

The AIC system will accept any audio cartridge recorded to NAB specifications, and by utilizing the AIC cartridge programmer, cartridges can easily be produced in library format for series production, or individually recorded for specific production.

I was particularly impressed by the potential cost-effectiveness of the AIC system, having watched the amount of studio time required for similar post-production efforts using techniques that were not really designed for the application to which they were being applied. As Kornbluth was quick to admit, his AIC systems may not be the answer to every single post-production audio-for-video problem that anyone has ever come up with, but it was clear to me that it was developed by a pair of men who have spent a good part of their lives in audio and video and are therefore keenly aware of the particular problems that are repeatedly encountered in these media.

If you'd like more information about the AIC System, or if you are in the New York area and would like a demonstration of this novel system, you can reach Jerry Kornbluth at (212) 541-9388. You don't even have to tell him I sent you. I think he and his partner Irv Robbin have come up with a system that can make life a lot easier for the post-production and audio-for-video engineer. ■

What you see is what you get...

For a catalog and a list of over 60 dealers in the USA and Canada, contact

Magnetic Reference Laboratory, Inc.
229 Polaris Ave., Suite 4
Mountain View, CA 94043
(415) 965-8187

Exclusive Export Agent: Gotham Export Corp.,
New York, NY

The MRL Calibration Graph is your proof of the quality control that goes into every MRL Reproducer Calibration Tape. We guarantee each one to exceed the performance requirements of IEC, NAB, AES, and EIA Standards.

MRL Calibration Tapes are designed and supported by experts in magnetic recording and audio standardization... we helped write the standards. Each tape comes with detailed instructions and application notes.

The MRL catalog includes tapes for all studio applications. In addition to the usual spot-frequency tapes, we make single-tone tapes, rapid-swept frequency tapes, wideband or 1/3rd octave-band pink random noise tapes, and difference-method azimuth-setup tapes. Most are available from stock.

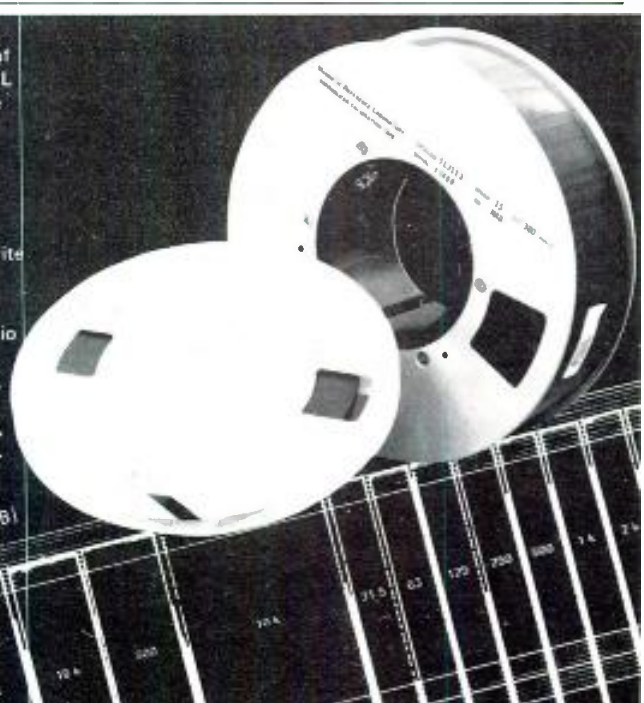

Circle 12 on Reader Service Card

California Here We Come

As this issue reaches your mailbox, we're about ready to pack our bags and head for the airport. Official **db** business demands that we go to Disneyland. Ellen Lane at Karson Travel seems skeptical:

"Aren't you a little, er... *mature* (she was thinking, 'old') for a vacation at Disneyland? How about Acapulco? I can get you a nice double for..."

"You don't understand, Ellen. This is business."

"C'mon, gimme a break, will you? By the way, if your publisher calls, where should I say you went this time?"

"Ellen, I'm telling you—business!"

"OK, OK, whatever you say. Hey Richard, he says he's going to Disneyland on *business!*" (Laughter.)

This little scene is probably being acted out all around the country, as countless hundreds (thousands, maybe) get ready to join Mickey, Donald and all the gang at the AES 72nd convention—the first-ever at a California fun spot (unless you count the downtown L.A. Hilton as a California fun spot).

Actually, the convention is taking place at the Disneyland Hotel, and not atop Magic Mountain, as some industry observers had been hoping for. Others are speculating whether the AES version of future-world on display in the hotel will out-draw the attractions surrounding it. We shall see.

Perhaps the festive atmosphere will help distract conventioners from the bleaker realities of doing business in countries outside the Magic Kingdom. We'll see about that too.

Here, in the real world, people are thinking twice—at least—about taking on any long-term financial obligations. You don't need us to tell you (but we will anyway): car sales are down, home sales are down, vacation travel is down, and the price of everything is up.

Is this the time to travel across the country to be introduced to even more high-tech (that is, high-\$\$) pro audio hardware? Apparently, it is. People just can't wait until happy days are here again—they want all that neat digital stuff, and they want it *now!*

Maybe it's a testimony to the basic validity of the digital audio concept, which seems to be attracting more and more of our attention these days. If so many studio owners are prepared to go digital despite the economic gloom, there must be something to it, beyond the mere novelty aspect of acquiring the latest audio "toy."

In this issue of **db** (nice segue, huh?) Anthony Agnello and Mark Clayton describe signal-processing capabilities that are almost beyond the comprehension of the analog-only mind. Meanwhile, Murray Allen cautions us against forgetting why we're in the studio in the first place. And Ham Brosious suggests a way of staying in that studio without blowing your entire fortune (if you still have one).

Maybe these three features should be packaged as **db's** Sort-of Survival Guide to the '80s: Learn what's new, don't forget what's old, and keep an eye on your bank balance. If you keep that in mind at the convention, you may even have enough money left over for one of the rides. See you on the mountain. JMW

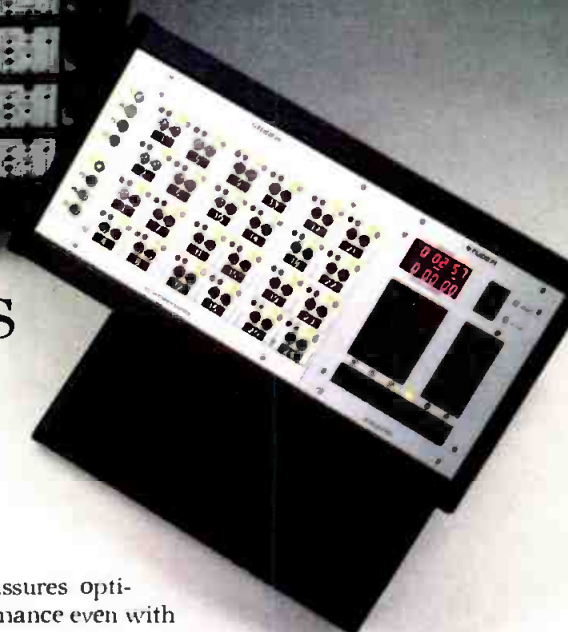

Studer's Secret of Success

In years past, the Studer A80VU has earned widespread acceptance by the world's premier recording studios. And this success story is far from over; top studios continue to choose the A80VU MKIII over other "all new" machines. The secret of this success lies in three basic rules:

1. If it can't be made better, don't change it.
2. If improvements can be made, make them—even if they don't show on the outside.
3. Use longer production runs to hold down final cost.

Now in its third generation, the Studer A80VU series once again offers state-of-the-art performance at a surprisingly modest price. The new A80VU MKIII system incorporates several significant improvements, including:

- **Transformerless Line Amps:** Low output

impedance assures optimum performance even with long cable runs.

- **New Headblock:** Tight spacing of erase and record heads permits exceptionally accurate punch-in and punch-out.
- **Remote Unit:** Full channel remote with 20-address memory autolocator.

Instead of repackaging these changes in an "all new" machine, Studer kept the basic transport—a design with an unprecedented reputation for reliability. Also, because basic tooling costs have long since been amortized, the A80VU MKIII's price has been held down, thus offering a better price/performance ratio.

How much better? Call your nearest Studer representative for details. He'll help make our secret the key to your success.

STUDER REVOX

Studer Revox America, Inc. • 1425 Elm Hill Pike, Nashville, TN 37210 (615) 254-5651
 Offices: Los Angeles (213) 780-4234 • New York (212) 255-4462 • Dallas (214) 760-8647 • Canada: Studer Revox Canada, Ltd.

Circle 16 on Reader Service Card

HERE!

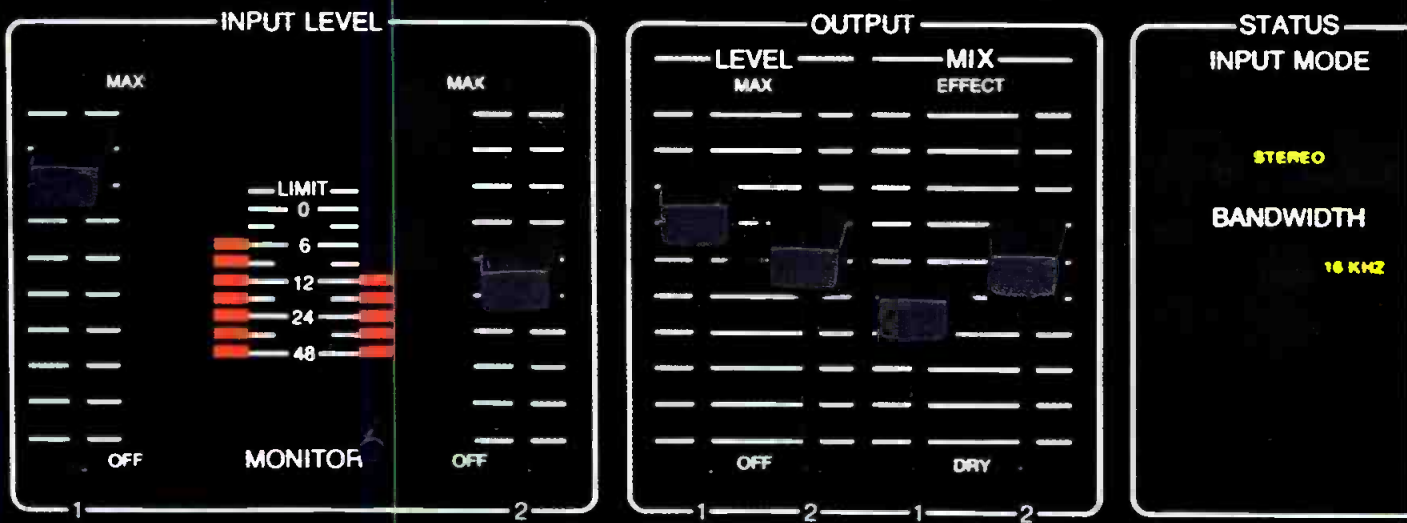

HEAR!

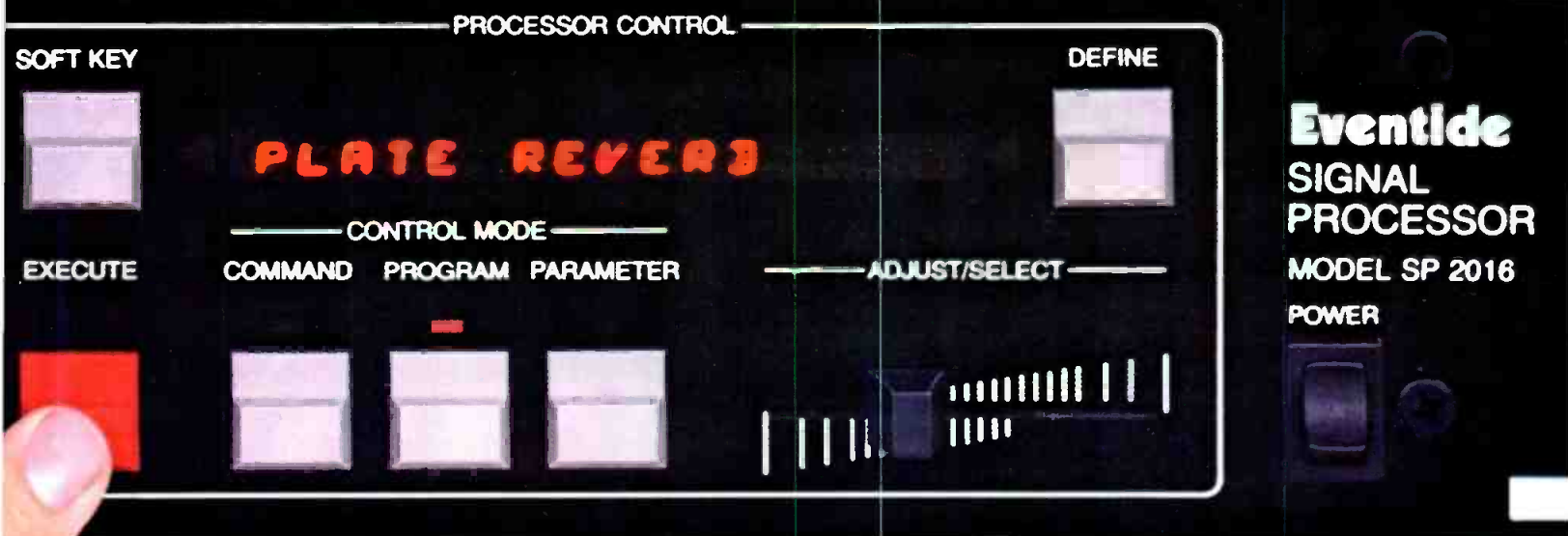

EVENTIDE'S NEW EFFECTS PROCESSOR REVERB PUTS A WHOLE NEW WORLD OF SPECIAL EFFECTS AT YOUR FINGERTIPS.

EVENTIDE TAKES THE NEXT STEP INTO THE FUTURE WITH THE SP2016, THE WORLD'S FIRST TOTALLY PROGRAMMABLE AUDIO SIGNAL PROCESSOR. FOR OPENERS, IT'S THE BEST SOUNDING, MOST VERSATILE **PLATE REVERB** **ROOM REVERB** DIGITAL REVERB EVER. YOU HAVE FULL CONTROL OF REVERB PARAMETERS (DISPLAYED ON AN EASY-READING ALPHA-NUMERIC READOUT) **PRE DELAY 16.4** **DECAY TIME 3.0** INCLUDING SOME YOU'VE NEVER SEEN BEFORE: **ROOM POSITION** **FRONT X REAR** BUT REVERB IS JUST THE BEGINNING. WITH AVAILABLE PLUG-IN SOFTWARE, YOU TAKE CONTROL OF A WHOLE NEW WORLD OF SPECIAL EFFECTS: **BAND DELAY** **DUAL DIGIPLEX** **MUSICAL COMBS** EVEN OUT-OF-THIS WORLD SOUNDS: **DUAL ROBOTS** YOU CAN CREATE AND STORE DOZENS OF

PARAMETER PRESETS FOR LATER RECALL: **SAVE USER PRESET** THE SP2016 TESTS ITSELF EVERY TIME YOU TURN IT ON: **SELFTEST** IT CAN EVEN HELP YOU WITH HOW-TO-USE INSTRUCTIONS. JUST ASK... **HELP-HIT RED KEY**

BEST OF ALL, YOUR SP2016 CAN NEVER BECOME OBSOLETE. WE'LL BE ISSUING NEW AND UPDATED EFFECTS REGULARLY. JUST PLUG THEM IN. AND WHEN YOU GO DIGITAL, HERE'S GOOD NEWS—YOUR SP2016 CAN HANDLE SIGNALS IN AND OUT *IN DIGITAL FORM*. YOU MUST SEE AND HEAR THE REVOLUTIONARY EVENTIDE SP2016 EFFECTS PROCESSOR/REVERB. IT'S A WHOLE NEW WORLD OF SPECIAL EFFECTS.

Eventide
the next step

FOR A "HANDS ON" DEMO CONTACT EVENTIDE FOR THE SP2016 DEALER IN YOUR AREA
EVENTIDE CLOCKWORKS, 265 WEST 54 ST., NEW YORK, NY 10019, TEL (212) 581-9290

Circle 23 on Reader Service Card

Audio Distortions on Both Sides of the Glass

With over thirty years in the business, author Allen is well associated with the problems of getting quality sound for commercials. Fortunately, he is also well associated with the solutions.

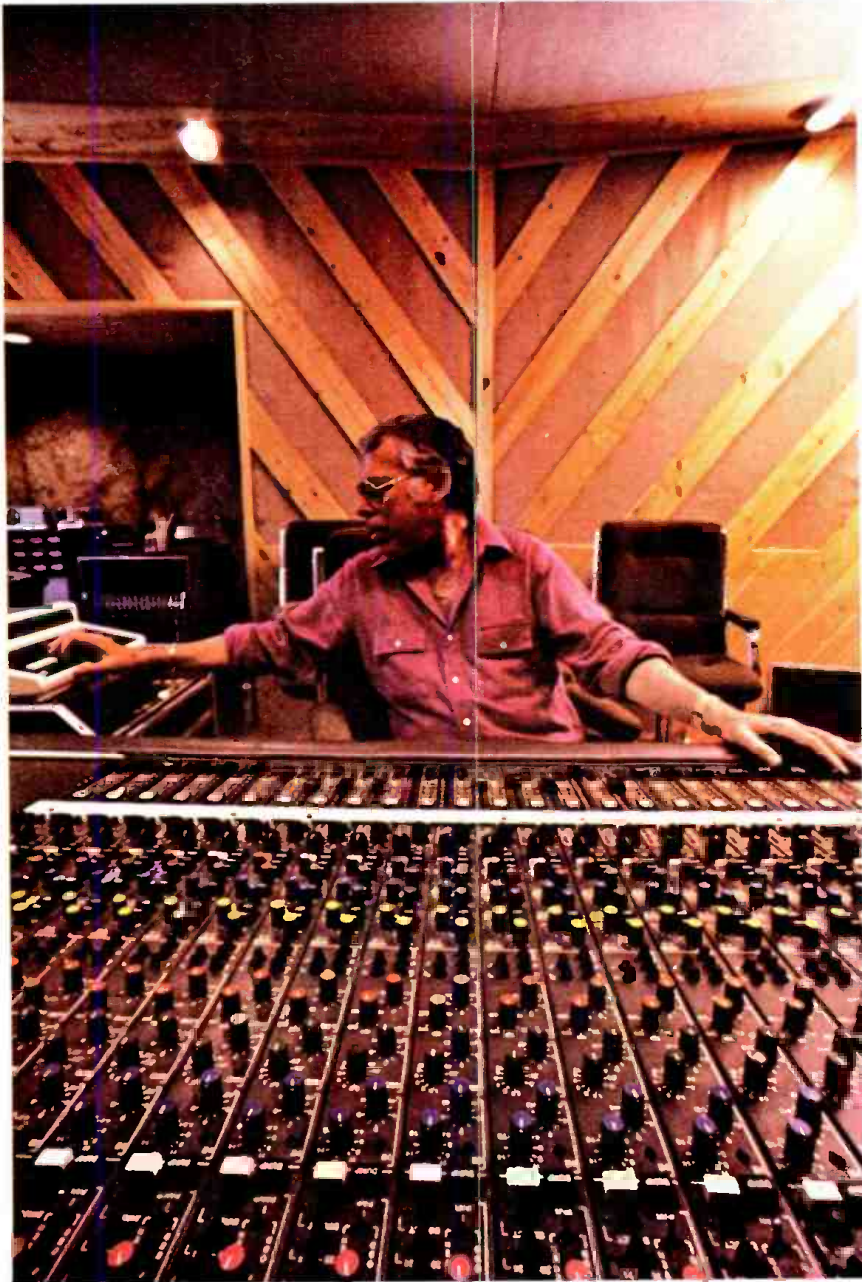



We're going to share our expertise in duplication.

We know a lot about duplication. After all, millions of our cassettes and open reel tapes are duped every day under conditions that can make you hopping mad. So, we had to learn how to make cassettes that sound terrific, last, and are as trouble free as possible.

Maxell gives you the cassettes you need, with the quality you must have. Tape ends stay anchored. Our shells have a five screw construction to eliminate warping. Maxell devel-

oped a four-function leader with A/B side indications, directional arrows, non-abrasive head cleaner and five-second cue to set timing and level. In performance, highs are clear and lows are solid and pleasing. On the business side, supplies are delivered when you need them. What more do you need to know about duplicating cassettes? Call us, we'll give you the name of your nearest Maxell distributor, quick as a bunny.



maxell®

PROFESSIONAL / INDUSTRIAL DIVISION

Our success is magnetic.

Maxell Corporation of America, 60 Oxford Dr., Moonachie, N.J. 07074 (201) 440-8020

Circle 21 on Reader Service Card

AS THE DAY of TV stereo approaches, there is a great deal of excitement and hope for its future. But, having been around the industry for over thirty years, I see technical *and* psychological stumbling blocks ahead. I summarize the problem by defining it as a psychological misuse of technology. The speed at which this technology is moving ahead is leaving some of the practitioners behind. And then there is the reluctance of one generation of sound mixers and musicians to learn from, or pass information on to, the other generation.

Let's take a look at the history of sound for TV commercials. In its early days, it was considered to be generally superior to radio-broadcast sound. But because of the above-mentioned problem, the sound of TV commercials has deteriorated, until it is now the worst audio foisted on the American public in over thirty years.

It doesn't have to be so. After all, "good audio" is, in reality, simply the absence of bad audio. Bad audio takes on the form of various types of distortions, both electronic and acoustic.

On the electronic side we have hum, noise, wow, flutter, saturation, compression, phase shift, drop-outs, and I.M. distortion, not to mention speed errors and poor frequency response.

On the acoustic side we have poor microphone displacement, out-of-tune and out-of-rhythm performance, lack of dynamics and perspective.

There used to be a rule relative to audio for film. "Use only one microphone. If you *must* use more than one, use at least four." The phase problems caused by two or three mikes far outweighs the good they will do. Today when one goes on a commercial shoot, more than likely the decision is made to use wireless mikes. Although these serve a definite purpose, they remove any audio perspective from the scene. As the actor moves up-stage, the sound doesn't. As two actors move close to each other, the voice quality changes due to the shifting phase relations between the mikes. These problems cannot always be

fixed in the mix.

In motion-picture film production, this type of bad audio is often replaced by having the actors re-record their lines while watching themselves on the screen. But the technique is used in less than one percent of TV commercials. The bad sound coming out of the field is left to fend for itself, causing more problems down the road.

In the early days of commercials, sound stages were often used. A great amount of time was spent getting the best audio. It was very common to use booms for holding the microphones. The audio man was usually on staff and had more control over the sound of the room. Distortions caused by standing waves and too much echo were eliminated on the spot. Then, portable tape recorders came on the scene, making on-location audio easier. Not better, just easier. Then there came the need for more portability, and the boom was eliminated. As shotgun microphones came into extensive use, audio acquired the problem of unwanted background noise. This brought on terrible problems in mixing, adding to the further deterioration of audio quality.

Finally, the wireless lavalier was introduced. This microphone requires an expert operator to make an actor sound normal. The three biggest problems these mikes create are: a sameness of sound whether the shot is close-up or wide, unwanted noise caused by clothes rubbing the mike, and phase shift as actors move around. If you are planning to use dialog replacement, these mikes are great, otherwise they can cause trouble.

The next step is dialog transfer. New 35mm stocks and new electronics should make this quite easy. If one is using an old-line house, the equipment is probably in good shape. However the problems of incorrect level and biasing still persist.

Engineers trained on rock-&-roll music often have problems understanding dialog transfer. In music, the standard level most used is 250 nano-webers per meter. Most engineers use VU rather than peak-program metering. An electric guitar's peak

BORN IN THE STUDIO,



THE TOA RX-7 SERIES

over VU might only be 3 dB plus the fact that tape saturation on certain musical instruments has become acceptable.

This engineer might set his level on the 35mm recorder at 250 nWb/m. If the field recordist let his dialog go into the red occasionally and the transfer engineer transfers using the field head tones, the following problems occur.

Assuming you are using the best stock available, at 250 nWb/m you will probably get around 9 dB of headroom at 1 kHz. The human voice sometimes has peaks far in excess of 9 dB over VU. This is especially true on "s" and "c" sounds. At these levels there will be a great deal of tape saturation. Many of the advances in music recording do not always create a desirable effect when applied to the recording or transfer of dialog.

To make matters worse, the multi-track technique of over-biasing is rarely used on film recorders. It should be. In the days of the vacuum-tube recorder, over-biasing was defined as peaking a 1 kHz signal, and then over-biasing until the signal level decreased about 1 dB on the VU meter. This was done to overcome drop-out. Of course, the top end fell off. The transfer engineer might add some equalization at his own discretion. In the era of solid-state, over-biasing means peaking some high frequency, determined by the tape speed, tape stock and head gap. At a level some 10 dB below operating level, peak that tone and then increase bias until tone decreases by the proper amount. Then, adjust input equalization on the recorder for flat output. Yet I have seen engineers raised on tube equipment use tube over-biasing on solid-state equipment. The distortion is dramatic.

Of course, the best stock is not always used for dialog transfer. Very often reclaimed or spliced stock is used. Now the problem is inconsistency of bias, and therefore of level, throughout one roll. In a ten-minute dialog transfer you may get the saturation effect of the rock-&-roll music man, the erroneous biasing by the "tube" engineer and then back again: just one more thing to be fixed in the mix.

The selected dialog transfer will, of course, be run across a

screening-room dubber's Kem or Moviola heads many times. There is a good chance these heads have not been erased recently. (Hopefully, the splicing block has been erased.)

Now comes the music session. This will be the single most expensive session for audio-only during the production of the commercial. You will see how much of the effort is wasted due to psychological hangups with technology.

When commercials were recorded years ago, the band and singers all worked together in the studio at the same time. Sometimes even the announcers were there. I remember recording Budweiser commercials in the early 60s with 40 musicians, 8 singers and 2 announcers all going to monaural while watching 35mm projection. Although we ran 3- and 4-track safeties, these were rarely used. If something got in the way of the voices, either the arrangement was changed or more likely the musicians played the passage differently. Since everyone was performing at the same time, the excitement of the announcer would turn on the singers who would excite the horns and strings who in turn would push the rhythm. The total interplay between all performers raised the quality of the performance.

In the late 60s and early 70s multi-track recording came into being. A new word became important, and misunderstood: "separation." In its most extreme definition, it meant that each musical element would be recorded on a separate track, totally free from any of the sounds surrounding it. This might include separating bass drum from snare drum from sock cymbal. To help with this technique, noise gates came into use. Eventually it was possible to totally eliminate the sound of the room.

This began the age of anti-gestalt music. Psychologically it was an expression of the times. It reflected the right of the individual over the general good of society. There was that feeling that the wheel was no longer as important as the hub, rim and spokes.

On the bright side, separation gives us techniques to record better rhythm sounds. Drums, bass, guitar and pianos never

BRED FOR THE STAGE.



*Crafted in Japan.
Proven in The States.*



TOA Electronics, Inc.
480 Carlton Court
S. San Francisco, CA 94080
(415) 588-2538
Telex: 331-332

In Canada:
TOA Electronics, Inc.
10712-181 Street
Edmonton, Alberta T5S 1K8
(403) 489-5511
Toronto: (416) 624-2317

CONSOLES 32X8, 24X8, 16X4.

Circle 49 on Reader Service Card

© 1982 TOA Electronics



The Studio A control room with engineer Bill Bradley (left) at the board.

sounded better. However, the sound of horns and strings suffered from tight miking. Microphones became quieter and more reliable but not necessarily better. The demand for vintage mikes bears this out.

Because of the misuse of limiters, compressors, equalizers, vocal stressors, noise gates, noise reduction and microphones, it is questionable whether the recording of voices has improved much over the last 20 years.

It now became possible to use small studios and record each part separately. On the economic side, this was good for studios. The rent was lower and they sold ten times as much studio time as before. For the artist it meant every part could be played over and over again until it was perfect. Economically it saved on performers, for one or two singers could do all the parts. Four strings could sound like forty and of course, the separation was fantastic. The only thing that was lost was the spontaneity and the level of excitement performers exude when playing together.

Hold on now; four singers multed, sound like four singers multed. It's not quite like eight singers. Four strings multing will sound like four strings multing, unless the musicians change instruments and seating position, which they never do. And what about that lost room sound? A whole new set of processors has been developed to restore this sound. The only problem is that there is no way to restore the audio that got lost by close miking. Acoustic instruments are just what their name implies—acoustic. They depend on a real acoustic condition to develop their sound. Any microphone or sound-processing technique that robs them of surrounding acoustics in fact distorts their sound. Unfortunately, many people growing up in the seventies have learned to accept these distorted sounds as the true sound of instruments.

When musicians and singers now perform, earphones are often their only aural contact with the other performers. On the bright side, the separation is maintained, and the rhythm time-lags common in recordings of the 50s and 60s are eliminated. Other eliminated elements are dynamics and intonation. Earphones cause the performer, or the mixer, to level out the

dynamics of a performance, in an attempt to create a good cue situation. The dynamics in an earphone are already limited since the sound is passing through mixing consoles and amplifiers. Intonation is bothered for two reasons. One is that everyone is stuck with the interpretation of pitch layed down on the basic track. Remember, pitch is psychological. The pitch we call "A-440" will tend to be *above* 440 in an ascending B-Flat scale, and *below* 440 in a descending E-Major scale. A string section or vocalist singing against a Fender Rhodes, or some relatively pure sounding well-tempered instrument, will actually have to perform psychologically out-of-tune or else sound out-of-tune. Second, perception of pitch is relative to intensity, distance and frequency. Earphones remove distance from the equation and they fool around with intensity. If a singer is flat, try turning up the volume on the earphones. The result may be that the singer sings sharper, but if it's too loud, they may sing flatter. Most people perceive pitch differently in each ear. In an acoustical environment this makes little difference. With earphones, many problems are created. By altering what information is fed to what ear, one can drastically alter the perception of pitch. Only highly-trained studio musicians and singers have overcome the earphone obstacle.

On the control room side of the glass, multi-track recording has created some problems for the industry. Although the multi-track recorder is probably the best tool introduced to the recording industry, the level of noise and flexibility it produces and how this noise and flexibility is handled is sometimes bothersome.

As we all know, every amplifier adds its own distortion to the signal. Although each amplifier by itself is rather harmless, the sum total of all amplifier distortions even be quite harmful. When one goes back and compares the finished sound with the original recording, the difference can be amazing.

In a typical music session, the music will pass through the microphone preamplifier, an equalizer, a line amp, maybe some processing amps, a noise reduction amp, and finally the input amp on the tape machine. What we hear is usually going through a mixing console, a one-third-octave equalizer amp

The face is young, but the credentials show fifteen years of experience in the industry. In seven years with A&R Recording and eight years as an independent engineer and producer, Elliot Scheiner has worked with the finest: Jimmy Buffet, Donald Fagen, Roberta Flack, Foghat, Billy Joel, Olivia Newton John, Ricki Lee Jones, Phoebe Snow and Steely Dan. With two Grammys as proof of his engineering skills, he now spends about a third of his time producing.

ON METHOD

"All of my recordings have basically been very, very clean. I like everything that's on tape to be heard, without strain to one's ears. My method is to clean up everything and make sure that everything that was intended to be heard is heard. I guess that's carried over to production. I don't really want to be categorized as... 'Oh yeah, his stuff is real clean, it always sounds good! I want to be able to make really good records of all types.'"

ON COMING UP

"I still feel the best way to learn about the industry is being in the industry. The recording schools teach basic fundamentals and that's OK. But it doesn't really apply. You have to go in there and experience it and get in trouble and work it out yourself. That's sort of how I grew up in the industry. I learned everything I know from Phil Ramone. But basically I started at the bottom and it was really the only way to go. It's a long process now days, but you learn a lot."

ON DIGITAL

"Well the first time I recorded in a studio with it, we were doing an overdub on a piano track and it was this wonderful grand piano, that sounded unbelievable in the room. We recorded it and I played it back for the first time digitally and it was like having my head under the cover of the piano. It's so real. It will have to get a lot more inexpensive to replace analog totally, but I definitely think that it's the future."

ON BAD EXPERIENCES

"There was a moment not too long ago when I got into the studio, producing and engineering, and I was really happy with what everybody was playing. The room sounded amazing that day. And when it came up to the first play back I was thrilled. We reeled back the tape and it starts to roll and it sounded terrible. There was no top end on the tape, the bottom end was ill-defined and I was embarrassed. We had a serious tape problem!"

ON TAPE

"One of the maintenance engineers suggested that I try 226. The first playback just astounded me, I was amazed. The top end, the bottom end, everything sounded exactly the way I was listening to it when it went through the console. And I became a 226 freak after that. I can't be bought, so if I say I like 3M 226 it's because I believe in it. I really feel strongly about the tape and what it's done for me."

SCOTCH® 226.
WHEN YOU LISTEN FOR A LIVING.

ELLIOT SCHEINER ON TAPE.

Magnetic A/V Products Division/3M
Scotch is a registered trademark of 3M.

3M hears you...

3M

Circle 22 on Reader Service Card

and a monitor amp. In earlier days, most of the equalization and level changes were left up to the musicians. A high-quality musician is much more capable of subtle equalization changes than any recording console.

As they are performing, musicians can momentarily alter their sound to suit the arrangement and the needs of the producer. The natural brilliance a musician can attain will always surpass the equalization of any console. To attain this result, choose the proper microphones and be creative in their placement. We often hear producers asking engineers to add more highs to the strings when it would be much more productive to ask the strings to play with more brilliance. If we could eliminate the equalizer, the processors and console amps, we could go directly from the microphone preamp to the tape machine. The results are always better — not always practical — but always better.

The modern analog recording engineer working on commercials has become the victim of a technological potpourri of engineering genius, totally unrelated to the art of music. *Music is produced by musicians.* The engineer's job is to create a comfortable environment for performance and to faithfully record the performance. Unfortunately, this is not how it is done. More and more of the musicians rights are being usurped by the control room staff. Remember: a simple performance adjustment by a musician can save hours of mixing.

Let's follow the path of a high-powered musical commercial from inception to broadcast.

During the original recording the engineer often adds equalization to almost every channel. A lot of this has become habit. Also, some of this is done to overcome the top-end saturation effect of analog tape. First rhythm is recorded, then the horns and strings are recorded, then the vocals. The singers are equalized and processed for vocal clarity. They will probably mult or overdub themselves once or twice. The mixer is listening in stereo, so he puts the original down the center and

the overdubs go left and right. Sounds great. Now it is time to mix—in mono.

Some of the vocal clarity gets lost because of shifting phase relations, so more top-end equalization is added. The basic rhythm tracks have lost some brightness because of the number of times they have been played during horn, string and vocal overdubs. Add some more equalization. But now the new rhythm sound interferes slightly with the vocals. A little more equalization is added to the singers.

After passing through many, many amplifiers, the mix is completed. It's a second-generation from the original. Now it gets transferred to 35mm stock, and becomes third generation. Hopefully, it won't pick up noise when it runs across editing machine heads. It now goes to the film mix.

The dialog tracks have different background noise levels, so an ambient-type background noise loop is added throughout most of the spot to overcome this problem. The sound effects are quite loud and require more equalization on the vocal tracks so they will be clear. Unfortunately, many of the subtleties of the original music mix are lost under the noise of the background loop and the sound effects.

The music is mixed to one track of a three-track film recorder. This becomes the fourth generation. The three-track film recorder has music on one track, dialog on another and sound effects on a third. This is all mixed down to monaural 35mm magnetic film.

And so we arrive at the final master mix. The original music has passed through more amplifiers than one would like to think about and has reached its fifth generation. The audio people now exit and the picture people carry the entire ball of wax.

Usually a copy is made of the master mix. This is generation number six. This copy will be run over inexpensive dubber heads making U-matic copies for agency approval. Hopefully, no noise will be added.

Now it is time for the tape transfer. We have found that unless



A drum set-up for a jingle in Studio A.

"No noise, nor silence, but one equal music."

John Donne, 1571-1631.

The new Klark-Teknik high-performance DN30/30 graphic equaliser offers much more than just a quiet ability to balance channels right across the audio spectrum. Thoughtful ergonomics are backed by a new circuit design breakthrough using ultra-stable microelectronic filter networks to set performance standards comparable with Klark-Teknik's 'golden oldie' the DN27A. The DN30/30 is the equaliser to boost a studio's reputation, meet broadcasting specs in less rackspace, cut costs and equipment failures on the road — because ...

It fits two matched high specification graphic channels into a single unit, each providing 1/3 octave equalisation over a full 30 ISO centre frequencies.

It gives fine fingertip low-frequency control covering the subwoofer range down to 25Hz — with touch-sensed centre detents, selectable cut boost level range and fail-safe design giving extra certainty during live events.

Its advanced design, tough construction, stringent testing and long burn-in exceed even Klark-Teknik's previously high standards for reliability and consistent performance on the road.

For technical information ask for:
Our DN60/RT60 Data Sheet.
Our DN30/30 Data Sheet.
Our Application Notes on equalisation.



KLARK TEKNIK
sound science

Klark-Teknik Electronics Inc.
262a Eastern Parkway, Farmingdale, NY 11735, USA.
Telephone: (516) 249-3660

Omnimedia Corporation Limited
9653 Côte de Liesse/Dorval, Quebec H9P 1A3, Canada.
Telephone: (514) 636 9971

Manufactured by Klark-Teknik Research Limited, England.



SOME MORE EQUAL THAN OTHERS

The microprocessor-based DN60 Spectrum Analyser and RT60 Reverberation Analysers provide LED matrix display of system, performer and studio response at 30 frequencies identical with those of the DN30/30.

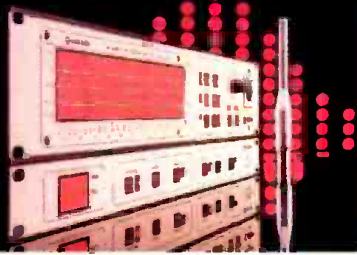

Circle 20 on Reader Service Card

We have on hand what you have in mind.

We had you in mind when we designed our PM-2000 mixer. That's why this is the mixer that more than meets your performance expectations. And feels the way you want it to feel.

The layout is simple and uncluttered. Yet the PM-2000 is sophisticated, versatile, and rugged. It's been proven equally adept in broadcast and recording, both at fixed installations and on the road.

With 5-position, 4-band eq, and six independent sends on all 32 inputs (24 channels also available), plus a full-function 14 x 8 matrix, the PM-2000 has earned a reputation as the consummate console. Distortion and noise specs are as low as much more expensive studio consoles.

Write to P.O. Box 6600, Buena Park, CA 90622 for complete information. We're confident that the more you know about the PM-2000, the more you'll realize it's the mixer you have in mind. And the PM-2000 is available at select Yamaha dealers now. So you can have it in hand, right away.

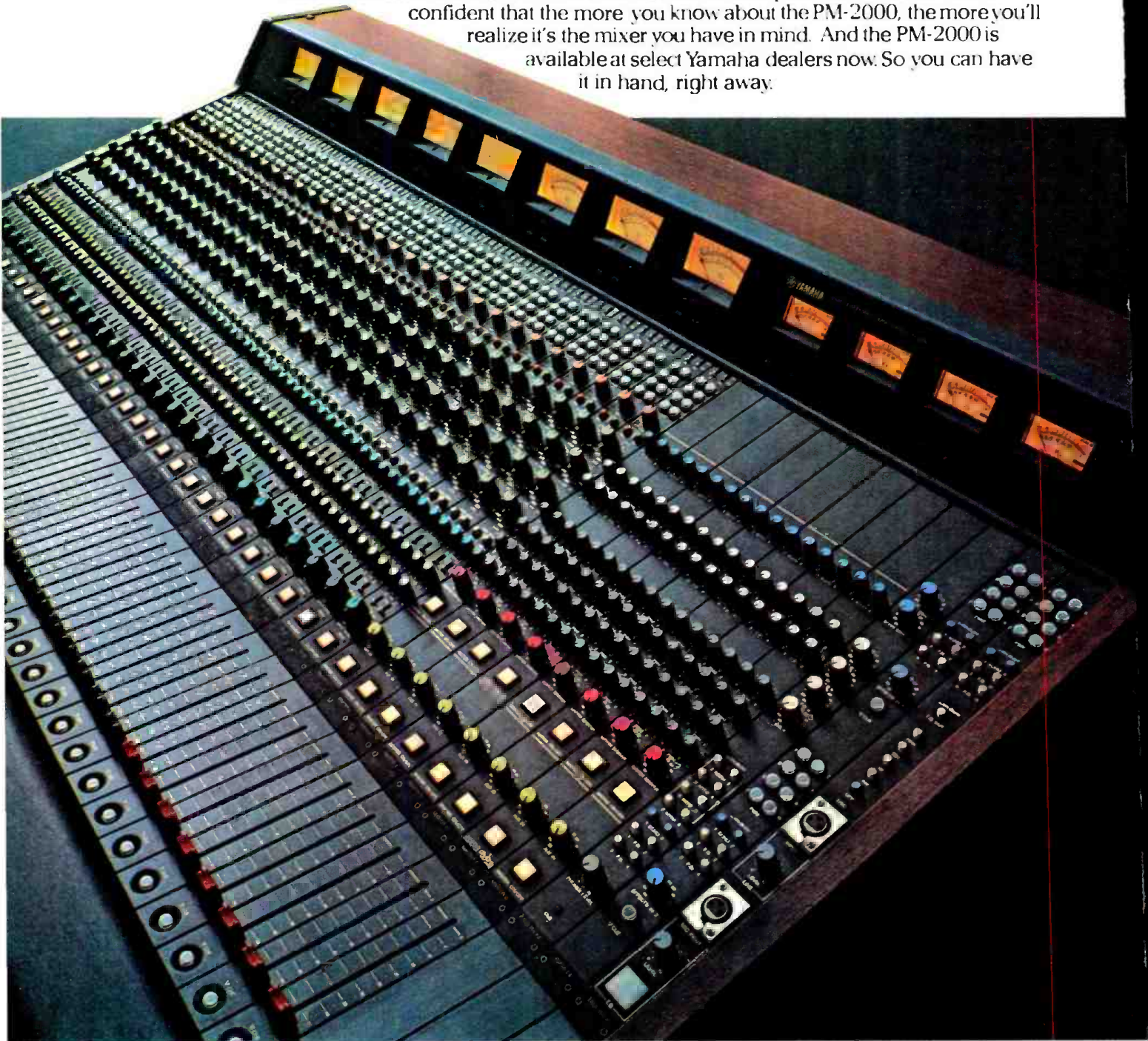

 **YAMAHA**

Circle 29 on Reader Service Card

experienced editors are present, more times than not the copy rather than the master mix will be used.

There is a very good chance that the videotape recorder being used has not been properly biased for the tape being used. By that I mean having been checked when that particular roll was put on the machine. Probably the equalization curve has not been checked recently either. And so, generation number seven is produced on a videotape, with less-than-optimum audio performance characteristics.

Copies from this master are made on cheaper stock and older machines and sent to the broadcast stations. We are now at generation number eight. When the station receives the copy it will probably copy it one more time for broadcast. So what we hear is now nine generations old, and scores of amplifiers away from the original.

On tests we have run, the best we have found between original music and the video dub sent for broadcast was a ± 5 dB across the frequency spectrum. This was in less than 20 percent of the cases. The worst was off by more than ± 8 dB, with an increase of noise above normal of 6 dB and hum of over 20 dB. Variations of these results are more typical.

Well, so much for the problems. What are the solutions?

The equipment we have today is the very best (providing it is used properly). There's no excuse for a video dub to be any noisier than specifications allow. Hum is totally inexcusable. Accuracy in the reproduction of the frequency spectrum is simple. Wow and flutter can be practically eliminated. Musicians are better than ever and are crying out to be allowed to contribute more to sessions.

Knowing all of the above, the following is the simple correct way to produce a sound track for a commercial. Simple, not easy.

While on location, try to get the best audio possible. If your film is not processed yet, use simultaneous videotape, or no picture at all. Try to use fish poles with mikes instead of lavaliers. Don't change mikes in the middle of a production (not even for voice-overs). Be aware of the distance actors are from microphones. If background noises create problems, be prepared to loop the voices later. If you are in or near a major center such as New York, Chicago or Los Angeles, book time in a dialog replacement studio before you release the actors. Or, you can loop right on location using two Nagra's and a stereo cassette recorder. The recorder used should be capable of recording audio, sync-pulse and SMPTE time code derived from the sync pulse.

Of course, there are situations where a tie-clip mike will do the job. I guess what bothers me most is not the professional use of these wireless mikes but rather the gross misuse which is becoming more noticeable all the time.

After the shoot, the negative film and original or looped audio should be transferred to videotape. From this point on all post-production will be on tape.

If possible, the music session should be recorded using digital equipment. Musicians, singers and announcer should rehearse at the same time. With the miking techniques and isolation capabilities available today, this can be accomplished. Set the orchestra in such a way as to minimize the time lag of acoustic leakage. You might want to use a drum booth to keep cymbals from splashing around. Every musician should be able to hear every other musician without the aid of an earphone.

Yes, everyone will have earphones. Give the rhythm a hot mix just as you hear it in the control room. The horns and strings should get single-earphones. Feed them click and voices only, and let them derive their pitch and feel acoustically. Because they have been spoiled, they might resist this at first, but the end result makes it all worthwhile.

The singers and announcer should rehearse in the studio but retire to an isolation room when recording begins.

The band for a 30-second commercial should be finished in about 30 minutes. If the singers feel they can do better, move them out into the studio again and let them overdub. Since they were part of the original recording, their performance will now have more meaning and excitement. They should be finished in about 30 minutes. By this time, the multi-track should be locked

to video playback.

The announcer, who has been rehearsing his lines for about an hour, can now deliver them while watching picture. Since he was part of the original recording, he will probably be quite close to a final take point (or at least all the timing problems will have been worked out).

Now comes the video sweetening. Let the clients leave for about an hour. During this time the original dialog or looped audio can be layed in on the same digital multi-track with original music, singers and announcer. If there are any sound effects, they can be layed in at this time.

Set up your console for automated mixing. Invite the clients back in. The mix will go quite fast since there is not as much to repair. Since you are still in the digital domain, problems inherent in many analog generations common to film mixing do not exist. All your time can be spent on creativity.

The final mix should be mixed directly to another digital machine, re-recording audio, sync pulse and time code on various tracks. At the same time, the audio mix should be layed down on the master videotape. (The picture has already been transferred.)

Total time, maybe four hours, and you have a high-quality video master with audio only one generation from the digital original. This gives your video master first generation analog audio as against seventh-generation audio using traditional means.

You can carry this one step further and transfer your digital monaural or stereo mix directly to the release dubs. This will make the release dubs first-generation analog as against eighth-generation in the standard method employed.

The total cost of using this method as against the standard methods (excluding layback on dubs) will probably be cheaper. You are avoiding duplication of efforts, costly re-do's because things don't work out when put together, and a great deal of time.

This example has to do with a post-scored, big-orchestra commercial. Variations of this technique can be applied to all other types of audio production.

So tell me: when we have a technology that will produce less-expensive, higher-quality audio, more than enough equipment to do the job, musicians, producers and engineers looking for better ways to do their job, why do the older technologies remain as the standard way of doing things?

A lot of it has to do with a lack of knowledge of new systems. There is also a safety factor in doing things in the same old way. Some people are afraid of trying anything new because of a fear of failure. There is also a group, because of their own selfish motivations or ignorance, who actually fights progress. These people are easy to spot. They make statements such as "Why use new equipment when you can't hear the difference?" "It's only a little speaker," etc.

Well the truth is, regardless of the speaker size, you *can* hear the difference. Bad audio can always be heard.

Many audio practices used in TV commercials are carried into the realm of TV program production. The use of multiple generations on analog tape, be it magnetic film or videotape, is quite common. Lack of interest in the integrity of the audio signal is shown by the second-class-citizen approach to audio in general by the television industry. Remember, videotape was designed primarily for video. It takes a lot of loving care to accurately record quality audio on this tape. For the most part this loving care does not exist.

In order for TV stereo to succeed, we are going to need pioneers, people not afraid to take chances, people who are truly in love with audio. In order for TV stereo to succeed, a great deal more effort will have to go into audio.

If the attitude is chosen to just take what we have now and put it into stereo, the result will be twice as much garbage as we presently have — plus the phase problems poor stereo will bring to the monaural listener.

If handled properly, stereo can be a major advance for TV, both artistically and financially. If not enough loving care goes into the studio, it just might turn out to be another Fdscel. ■

Digital Audio Processing— The Next Step

Look out, here comes the super-processor!

LOOK AROUND! The world is full of stuff designed to affect audio signals: amplifiers, mixers, equalizers, analyzers, fuzz boxes, compressors, expanders, limiters, modulators, reverberators, pitch changers, vocoders, chorusing devices, flangers, phasers, delay lines, filters, de-essers, "exciters," etc. Each of these devices is designed to process audio in its own special way. A typical recording studio will have many of these devices in various combinations, but no matter how many there are, one never has enough of everything. At any given time, someone will want to add just one more effect to just one more signal. This rather obvious observation suggests yet another corollary to—MURPHY'S LAW.

"The number of things to do will always exceed the number of things available to do them."

In an attempt to use existing equipment more efficiently, some studios have available a portable rack of outboard gear which can be moved to where it is needed. Not a pretty picture, is it? Imagine, actually moving things around! There must be a better way.

A BETTER WAY

There is (or will be) a better way, through the "miracle" of digital signal processing. But for the moment, each processing device performs essentially a single function. The functions that these various devices perform are not interchangeable; in fact, different devices which perform identical functions are not interchangeable (ever try to adjust an FMT 251 digital reverb to sound like an FMT 140 plate?).

In other words, while each device affords some degree of processing power, that power is locked into performing one, and only one, function. We can't use the processing power inherent in an equalizer to perform a limiting function. The inability to share processing capability results in poor utilization of available resources. If, instead, we could somehow centralize all the processing power in one general-purpose unit (endowed, of course, with more power than we could ever conceivably require) and exercise total control over its every operation, we would achieve maximum efficiency.

This is only the beginning. Such a general-purpose device (digitally, naturally) offers several other advantages:

First, digital signal processing techniques can perform functions not possible with analog components (e.g. precise linear-phase filters). Second, undreamed of performance would be possible if a large part of the available processing power were dedicated to a single function. (We're talkin' nearly-perfect filters, super-dense reverbs, etc.) Third, total and precise control over every aspect of processing would be possible.

STL

PRECISION



MAGNETIC TEST TAPES

STANDARD TAPE LABORATORY, INC.

26120 EDEN LANDING ROAD #5 HAYWARD CALIFORNIA 94545 • 415 786.3546

25,000 copies in print

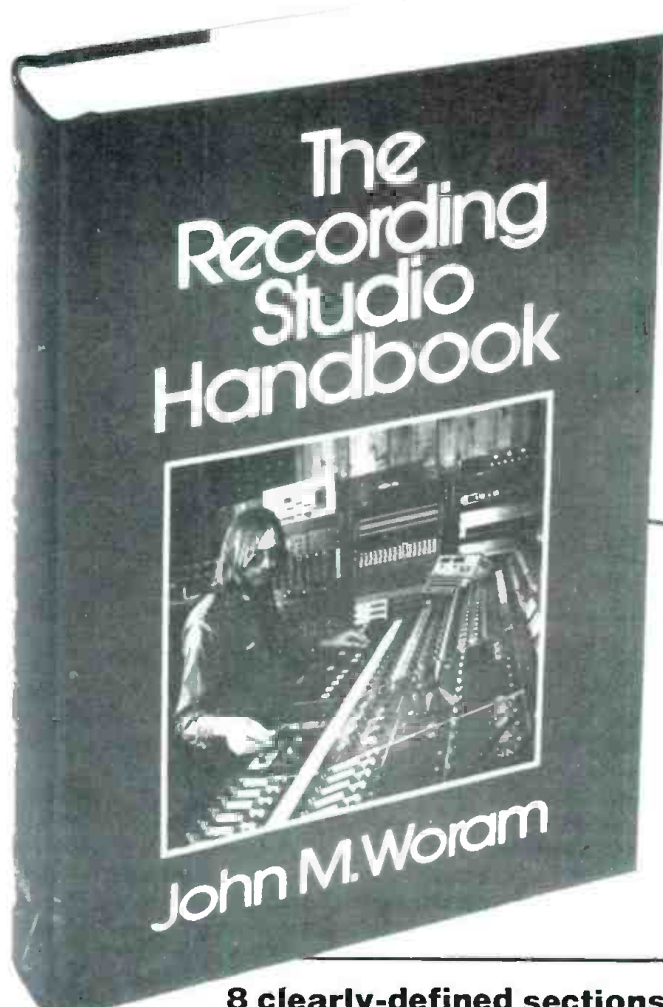

Fifth big printing of the definitive manual of recording technology!

"John Woram has filled a gaping hole in the audio literature. This is a very fine book . . . I recommend it highly — *High Fidelity*. And the *Journal of the Audio Engineering Society* said, "A very useful guide for anyone seriously concerned with the magnetic recording of sound."

So widely read . . . so much in demand . . . that we've had to go into a fifth printing of this all-encompassing guide to every important aspect of recording technology. An indispensable guide with something in it for everybody to learn, it is the audio industry's first complete handbook on the subject. It is a clear, practical, and often witty approach to understanding what makes a recording studio work. In covering all aspects, Woram, editor of *db Magazine*, has provided an excellent basics section, as well as more in-depth explanations of common situations and problems encountered by the professional engineer.

It's a "must" for every working professional . . . for every student . . . for every audio enthusiast.

8 clearly-defined sections 18 information-packed chapters

I. The Basics

The Decibel
Sound

II. Transducers: Microphones and Loudspeakers

Microphone Design
Microphone Technique
Loudspeakers

III. Signal Processing Devices

Echo and Reverberation
Equalizers
Compressors, Limiters and Expanders
Flanging and Phasing

IV. Magnetic Recording

Tape and Tape Recorder
Fundamentals
Magnetic Recording Tape
The Tape Recorder

V. Noise and Noise Reduction

Noise and Noise Reduction Principles
Studio Noise Reduction Systems

VI. Recording Consoles

The Modern Recording Studio Console

VII. Recording Techniques

The Recording Session
The Mixdown Session

VIII. Appendices

Table of Logarithms
Power, Voltage, Ratios and Decibels
Frequency, Period and Wavelength of Sound
Conversion Factors
NAB Standard
Bibliography
Glossary

Use the coupon to order your copies today at \$37.50 each. And there's a 15-day money-back guarantee.

ELAR PUBLISHING COMPANY, INC.

1120 Old Country Road, Plainview, N.Y. 11803

Yes! Please send _____ copies of THE RECORDING STUDIO HANDBOOK. \$37.50. On 15-day approval.

Name _____

Address _____

City/State/Zip _____

Total payment enclosed \$ _____
(In N.Y.S. add appropriate sales tax)

Please charge my Master Charge
 BankAmericard/Visa

Account # _____ Exp. date _____

Signature _____
(charges not valid unless signed)

Outside U.S.A. add \$2.00 for postage.
Checks must be in U.S. funds drawn on a U.S. bank.

Fourth, digital control would assure absolute repeatability.

This super-processor will doubtless exist someday and in fact is one of the promises of digital audio. Simply stated, the super-processor ensures the optimum use of available resources. (For an excellent introduction to the world of digital signal processing, see Barry Blesser's Digital Audio column in this and previous editions of *db* magazine.)

TOMORROW

Imagine. It's the future and it's digital. Totally digital. Transducer technology (microphone, converters, etc.) has advanced to the extent that the operations of signal detection, encoding/decoding, storage and reproduction are "perfect." Absolute fidelity has been attained. ("Is it live or is it digital?")

This degree of fidelity should be obtainable by using a sufficiently large number of bits (24?, 32?, ...?) and sampling at a sufficiently high sampling rate (100 KHz?, 1 MHz, ...?). (Just what is the sampling rate of reality anyway?)

While the audio engineer's tools have changed radically, the task remains the same: modify the audio signal in some artistically and/or technically desirable way. How can these modifications be accomplished most effectively?

Assuming that the prerequisite hardware exists, a super-processor could be designed which would perform any and all desired signal modifications. In effect, it would do *everything*, do it perfectly, and do it in real-time.

The super-processor would:

- 1) Maintain absolute fidelity.
- 2) Have sufficient processing power to perform all usable combinations of signal modification (all in real-time, of course).
- 3) Provide total user control via high-level software.

Possibly the most important aspect of processor design is the ease with which it can be manipulated by the user. Assuming, as we have, that the processor can do everything, the challenge is to present this power to the user. How can we make it most

useful? In a word, software, software, and yet more software.

Once scenario might be:

The producer asks for a circa-1970 rock-'n-roll feel for the vocal. The engineer turns to her/his computer terminal and selects MICROPHONE from a menu of sound-modification devices. The terminal next displays a catalog of available microphone simulations. From this list she/he chooses a Neumann U87 simulation. The vocalist is now, in effect, singing into a Neumann U87. Next the engineer selects LIMITER from the device menu and Teletronics LA2A from the limiter sub-menu. The limiter is now in-line and the front panel of the LA2A appears on a large, high-resolution display device. The engineer adjusts the controls on the display while the touch-sensitive surface responds to his every move. The producer smiles. Pretty neat, huh?

You might say it sounds far-fetched or even, "Who cares?". But the point is that while the above may be a silly example, the overall concept is quite feasible. On the other hand, it is much easier said than done. Such a system would require an awesome software effort. The software which controls the operation of the processor by determining how the processor accepts inputs, controls the processing hardware and displays information to the user is called the Operating System (OS). Creating an OS capable of the types of high-level user interaction described above would be quite a challenge. In addition to the OS, simulation software would have to be developed for every existing piece of hardware which we wish our processor to emulate.

This means that each piece of equipment would have to be painstakingly analyzed. Application software would have to be created and made available to the processor, thereby enabling the processor to duplicate precisely the effect of the real device. In addition, software which defines the "soft" device's front panel and control features would be needed. Although this would require a vast effort, there is one small consolation. It would only have to be done once for each device. For, once written, the software will completely characterize the device.

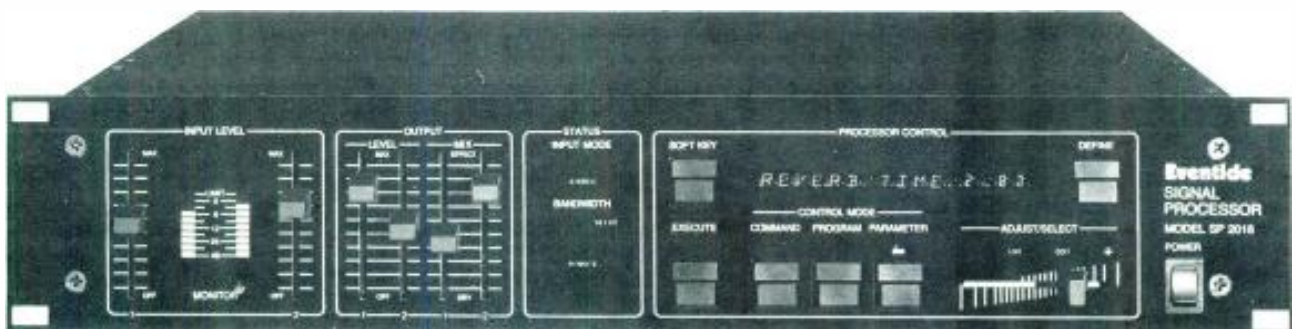

The SP2016 programmable effects processor.

Suddenly, everyone else has to start over.

PASSIVE COOLING
No fan noises. No internal dust build-up.

FRONT REMOVABLE CHANNEL MODULES
All electronics for each channel can be exchanged while amp is in rack.

HIGH POWER/LOW PROFILE DESIGN
Using high efficiency output circuits for cool, high reliability operation.

CENTRAL WELDED STEEL AC AND TRANSFORMER BAY
For maximum strength and shielding.

FLOATING INTERNAL CONNECTOR SYSTEM
Prevents contact damage from road vibration. All gold contacts in signal level path.

TRUE DUAL MONO CONFIGURATION
Two completely separate amps only sharing common AC cord for maximum reliability and flexibility. All protection separate for each channel.

HIGH DYNAMIC HEADROOM AND MULTIPLE PARALLEL, LOW ESR FILTER CAPACITORS
Provides exceptionally tight, high-impact bass performance.

COMPREHENSIVE INTERFACE PANEL
Includes 1/4" RTS, XLR, and barrier inputs. Provision for active or passive accessory input modules such as crossovers, filters, limiters, and transformers. Binding and barrier outputs provided.

REINFORCED FRONT AND REAR RACK MOUNTS.



OVER-TEMP WARNING LIGHT
Begins flashing 10°C before thermal protect.

PRECISION 31-STEP DETENTED GAIN CONTROL
Gold plated wiper and sealed body design assures accuracy and freedom from sonic degradation.

LEVEL INDICATORS
To monitor output.

CLIP INDICATOR
Flashes during all types of distortion.

SEPARATE AC SWITCHES
Enable single channel to be powered up or down. Useful for emergency speaker changes during performance.

POWER/PROTECT INDICATORS
Monitor status of Load Grounding™ protection relays. Relays provide delayed turn-on, instant turn-off, DC, sub-audio, power interrupt, and over-temp protection.

RECESSED CONTROLS
Prevent damage and accidental movement.

FRONT MOUNTED CIRCUIT BREAKERS
No fumbling around in the back of the rack.

MASSIVE OUTPUT SEMI-CONDUCTOR SECTION
Assures long-term reliability under abusive conditions.

Series Three from QSC. From this point on, every other power amplifier takes a step backward.

We've designed what will be the standard from which everything else is measured.

Series Three combines high-performance, reliability, and microscopic attention to detail, design and the execution thereof.

Our overall goal was to provide a series of reference-quality professional amplifiers designed specifically for major studios, touring companies and engineered sound installations.

We met our goal. As a matter of fact, we significantly exceeded it.

Take a look at the features of our Series Three amplifiers. High-efficiency circuitry, extended dynamic headroom, true dual-mono configuration, front-removable modular design. And we've packaged it all in a low-profile chassis. More power, less rack space. We were so impressed with our prototype Series Three amps that

we decided to take them into the field for numerous "A/B" listening comparisons. They were compared for audio quality and performance under a wide range of power requirement conditions. As we had expected, the response was overwhelmingly positive. The Series Three amplifiers stood a significant step above the others.

The moral of the story: Why settle for a product that's only outstanding in a few areas? QSC Series Three is a comprehensive design approach that combines exceptional audio performance, solid reliability, state-of-the-art features, and more power in less rack space.

So we urge you to look into our Series Three amplifiers. Because while everybody else is looking where they've been, QSC is stepping into the future.

QSC Audio Products, 1926 Placentia Avenue, Costa Mesa, CA 92627. Phone: (714) 645-2540.

QSC
AUDIO

Think what this means: the actual physical device becomes unnecessary. This implies a kind of freedom. No longer will we be burdened by a gaggle of interconnected physical devices each with its own hardware (which must be documented and maintained) and its own idiosyncrasies. Devices would exist only as information (data files), an entirely non-corporeal existence.

Whenever a particular device is needed, a small portion of the super-processor becomes a "soft" version of the desired unit, complete with all of its associated controls. To all intents and purposes, this "soft" device would be identical to the real unit. In essence the software is the unit. In this world, every user would instantly have available every unit ever created. (That's right, every unit ever created.) Audiotopia. Wow.

The super-processor will not be available for quite some time. But the first step has been taken.

YESTERDAY... THE BEGINNING

In 1976, Eventide began an investigation of the process of reverberation. A prototype digital reverb was designed and tested which was capable of performing, in real time, the reverberation algorithms proposed by M. R. Schroeder in the early '60s. (See "Natural Sounding Artificial Reverberation" in the July 1962 *AES Journal* Ed.) Prior to this time, these algorithms had been programmed and run on large mainframe computers with the audio signal processed in non-real time, making critical listening tests impossible. The Eventide prototype demonstrated to us that the Schroeder algorithms were not sufficiently complex to convincingly simulate natural-sounding reverberation.

This research did, however, indicate the amount of processing that would be necessary to achieve high-quality reverberation simulation. While contemplating the design of such a second-generation digital reverb, it became clear that a device with the degree of processing power necessary to create high quality reverberation would also be powerful enough to perform many other functions, some unrealizable with analog techniques. We realized that a totally-programmable general-purpose device might afford unrivaled performance as well as unequalled control capabilities, whether it was functioning as a reverberation device or perhaps as something else.

FAST, DEEP AND WIDE

The "number-crunching" ability of a signal processor determines what functions it can perform and their quality. Three major factors determine this. They are: the speed of the processor, the number of words of data memory, and the word width. Digital audio data comes along at a fixed rate, called the sample rate. A processor that can execute instructions at 256 times the sample rate can run a 256-step program during each data sample. Increasing the speed of the processor or lowering the sample rate increases the power of the processor. The trade-

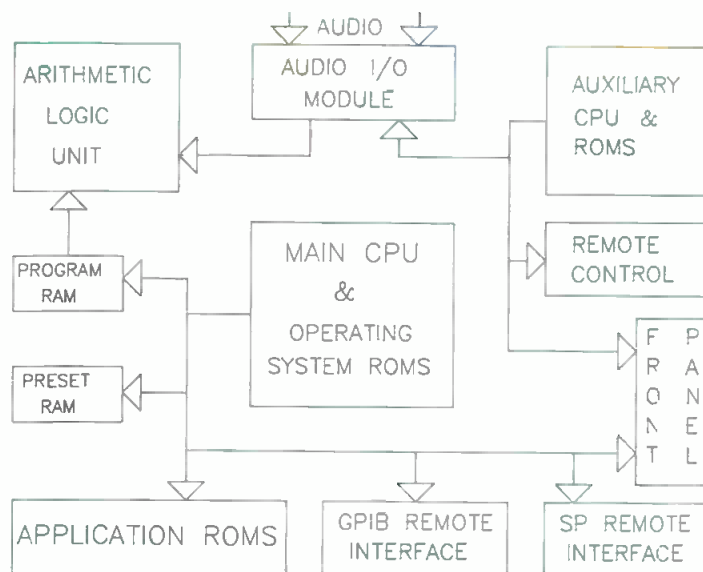

SP2016 dual digiplex program block diagram.

offs are higher hardware costs or reduced audio signal bandwidth. For example, Eventide's SP2016 signal processor is capable, under program control, of operating at half bandwidth (8 kHz) with twice the processing power. (For the purposes of further illustrating what can be expected from the latest generation of signal processors, some features of the SP2016 will be described below.)

A common function of an audio signal processor is to delay a signal from a few microseconds to a few seconds. The number of data words a processor can store determines its memory depth. There is a high demand for very dense memory chips for many types of products and Silicon Valley has not disappointed anyone in this regard. While a 320-millisecond delay line cost \$4100 a few years ago (using 1024-bit memory chips), we now have 6.4-second delay lines at a third the size and about half the price. This has been made possible by the latest development in high-density memory chips, the 64K RAM. These chips store 65536 bits of data in the space of a thimble. The length of delay available is dependent on the sample rate (which determines the signal bandwidth), the depth of memory and the number of channels.

THE SOFTWARE

A signal processor's hardware determines its ultimate capability and capacity, but the software determines what it does and how it does it. A complex processor is programmed on many different levels. The most primitive level is the instruction set of the signal processor itself. These instructions move, add, subtract or multiply the incoming data. We shall call a series of these instructions an ALU (Arithmetic Logic Unit) Program. Whether the processor is a reverb or a delay line is determined by the ALU Program.

The area in which the ALU program resides is called the Program RAM (Random Access Memory). But how does the ALU program get into the Program RAM? And how can it look at front panel keys and blink lights when it's so busy processing the audio data? It can't. These functions are performed by a pair of microprocessors, referred to as the Main and Auxiliary CPUs. These CPUs are in charge of loading ALU programs, responding to the front panel controls, displaying information on the front panel, managing various remote control devices, and controlling the I/O module. The OS program performs the above tasks, and defines the operating rules of the processor. All front-panel controls and indicators are connected to the CPU. Pressing a key informs the OS that the key has been pressed. The OS determines what function the key will actually perform.

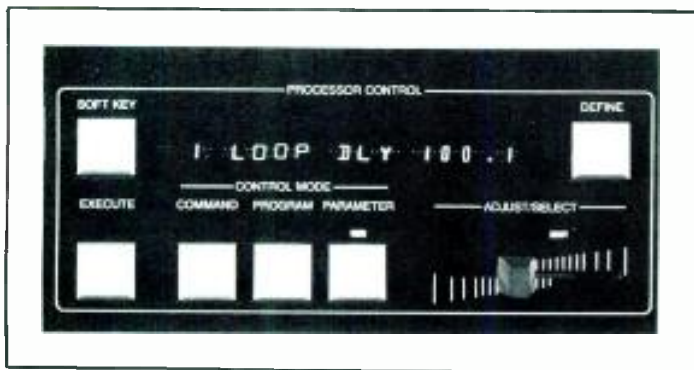

Close-up of the processor control section of the SP2016.

There must be a way to modify the parameters of an AIU program after it is loaded. For example, a reverb program will have a certain standard setting for reverb time, room position, etc. To change these parameters, the AIU program is modified by the Operating System. The OS follows a set of rules that are stored with the AIU program. The rules control the numbers and type of parameters that can be changed.

AIU programs and their parameter rules are stored in ROMs (Read-Only Memories). To add a program, a new ROM is plugged into any empty socket.

SOFTWARE CONTROL

A general-purpose device requires a general control scheme. You can't have a separate key to load each program if there may be up to 100 programs, half of which haven't been written yet. The solution is to make the operation of the signal processor "list-oriented." The idea is to provide a few operating modes and list the function of each mode on an alphanumeric display. Such a display will allow the device to speak the user's language. By displaying both numbers and letters, as directed by the Operating System, unambiguous yet flexible user control is possible.

In the Eventide SP2016, there are three basic modes of operation. PROGRAM mode lists the AIU programs that are installed, PARAMETER mode lists the parameters available for a particular program, and COMMAND mode lists miscellaneous system functions such as saving user presets, controlling line in-out status, running diagnostic tests, etc.

DOING IT

Let's run through a session with a general-purpose processor, using the SP2016 for illustration purposes. When the unit is turned on, it does a complete check of its internal circuitry. Assuming all is well, the processor will load the program that was running when it was last turned off.

Selecting a program—

The light above the Program key is lit indicating the system is in PROGRAM mode. When the light is flashing, the display is showing the name of the program you are hearing. To see the names of the other programs that are available, either press the

modified by the user.

While in parameter mode, the Adjust Select fader is used to modify the value of the displayed parameter.

The Define key is a user aid which provides additional information about the currently-displayed message. In parameter mode, the Define key will describe the function of the parameter or define the units of the number in the display. In the other operating modes, the Define key indicates what type of data is in the display window. For example, let's assume the parameter key displays FEEDBACK 50.0. The Define key will show that the 50.0 refers to a percentage of full level. 100 percent feedback is equivalent to infinite repeat.

Soft key function—

It would be useful if there were a way to temporarily zero the feedback in order to clear the memory of the previous sounds. In fact, most programs can benefit from having some auxiliary functions such as repeat for a delay program or input mute for a reverb program. The "Soft key" on the SP2016 performs this function. As the name implies, the function of the Soft key is determined by the software. Each program can have many different Soft key functions although only one can be active at a time. Press the Soft key and the display shows: ZERO FEEDBACK. The loop feedback is now set to zero. Press it again and the display shows: RESTORE FEEDBACK. The feedback is now reset to its original value. Other Soft key functions can be selected by entering the Command mode.

The Command mode—

Operations which do not directly affect the audio processing, like saving and erasing user presets, are known as SYSTEM COMMANDS. The Command mode is used to select these commands.

Press the Command key and the first command mode function is displayed. This system command lets you select the active Soft key function. Press the Command key. The display shows: HELP-HIT RED KEY. Hit the red Execute key and the display will list a brief set of instructions. Moving the Adjust Selector fader lets you control the rate and direction of text motion.

BUS ADDRESS

The GPIB (General Purpose Interface Bus) is widely recognized as an efficient means of controlling equipment using a small computer. The GPIB interface is standard on all SP2016s. Up to 14 devices can be connected to the bus so each device must have a unique number or address. The Bus address command function is used to set that address.

A NOTE ON OBSOLESCENCE

A feature of a truly general-purpose signal processor is its resistance to obsolescence. While processors will certainly become more powerful (indeed it is probable that someday the equivalent of a large portion of the SP2016 will be available on a single chip) today's processors should continue to be useful for applications requiring their degree of processing power. In addition, as new processes are developed, processors such as the SP2016 can be re-programmed to take advantage of such progress.

FUTURE APPLICATIONS

Eventide is currently working on several new programs and contemplating a good many more. For obvious reasons we cannot reveal exactly what we are up to. In fact, we are not entirely sure what the final versions of existing programs will be. At this point, the possibilities seem unlimited. While we feel we know the types of things we should be doing, we can't do all of them at once. Setting priorities is the most difficult task of all. What's next? We're not quite sure.

Any suggestions? ■

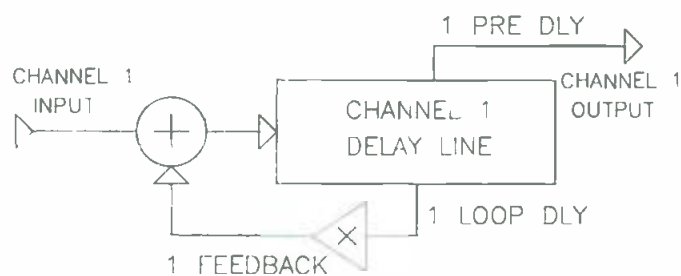

CHANNEL 1 PARAMETERS: 1 PRE DLY (.1 to 800 MSEC.)
 1 LOOP DLY (.1 to 800 MSEC.)
 1 FEEDBACK (-99.9% to 99.9%)

DUAL DIGIPLEX PROGRAM

(CHANNEL 2 IDENTICAL...NOT SHOWN)

SP2016 system block diagram.

Program key or move the Adjust Select fader. If a program name strikes your fancy, strike the Execute key. This will load the displayed program and you will hear it immediately.

Modifying the program—

Parameters are aspects of program effects which can be

New Sound in the Round: The Greatest Show on Earth Goes Omni...

Presenting a stunning salvo of sonic splendor, riveting and reverberating with robust reality.

IN THE DESIGN OF SOUND for a theatrical performance in, let's say an arena, the state of the art dictates that success will be achieved by following certain basic rules. Hardly disputed by anyone are the following:

1. Pick up all sound with directional microphones. This reduces tendency for feedback, provides a greater ratio of direct-to-reflected sound and helps to separate sources such as instruments in a band.
2. Equalize each microphone signal to achieve the desired sound. Mixing consoles should be equipped with an equalizer for each output.
3. Provide a slide-type level control for each console input so the balance of signals can be easily altered during a performance.
4. Hire a sound engineer to preside over this multitude of controls.
5. Equalize the resulting mix with filters of one octave or less to compensate for deficiencies in loudspeakers and room acoustics.
6. Reproduce the final result through directional speakers, focused so that sound is aimed at the audience and not at surfaces of the room which will reflect excessive echoes and reverberation.

All these rules are currently being violated by the 112th edition of Ringling Brothers and Barnum & Bailey Circus now touring arenas across America. The result is (in typically modest circus terms)...a stunning salvo of sonic splendor, riveting and reverberating with robust reality. In other words, the sound system designed by Future Sound, Inc. of Weston, Connecticut, appears to have solved many of the long-standing problems of arena sound; this is the opinion of professionals who have toured arenas for many years.

Reviewing the six rules above, which by no means are the only ones, a tendency of increasing confinement and control may be noticed. Inspired perhaps by the circus atmosphere, our design approach was to back off a bit. Boost controls came down, filters were switched off, microphones were backed up and speaker and microphone coverage angles were increased. To those present during this process the effect was like opening a window on an atmosphere too long stilled by specialization.

SPHERICAL SPEAKERS

Undoubtedly the most unusual element of the system is the loudspeaker, a purposely non-directional creation. In principle, a 22-inch diameter fiberglass sphere forms a vented enclosure for a 15-inch driver. The inherent rigidity of a sphere allows the

wall thickness to be decreased, affording a strong lightweight structure. The main purpose of the sphere however is to function as a nearfield sound scatterer. The driver works directly into a curved reflector which steers the sound energy back over the sphere where it is scattered smoothly in all directions. The sphere's organic shape makes it a natural for such an application. For the same reason it is considered to be the ideal loudspeaker enclosure. The sphere has no discontinuities or sharp edges to cause diffractive interference effects.

The preceding discussion applies, however, only to certain frequencies. An object is only an obstacle to sound when its gross dimensions are comparable to that sound's wavelength. For reference, the wavelength of a 20 Hz tone is about 50 feet, 100 Hz is 10 feet, 1000 Hz is one foot and 10,000 Hz is one inch.

Since the device under discussion has a diameter of roughly two feet, sound frequencies below 500 Hz do not see either the sphere or the reflector as obstacles and simply go around them. They are therefore radiated evenly in all directions. Frequencies above 500 Hz are steered by the reflector and scattered by the sphere. The question might rightly be asked—"Why not remove the reflector and the sphere and allow all frequencies to radiate in every direction?" The answer is that loudspeakers, by nature, form the sound into a narrow beam when the wavelengths involved are shorter than the cross-dimensions of the loudspeaker. A 15-inch diameter speaker can only radiate frequencies from 20 Hz to 200 or 300 Hz omnidirectionally.



The Soundsphere 22 omnidirectional loudspeaker.

Bill Lobb is a consultant to Jaffe Acoustics, Inc. and special consultant for Future Sound's Ringling Brothers Project.

depending on the size of its enclosure which also figures in the gross dimension. The scattering reflector sphere combination causes the radiation to be omnidirectional up to the highest frequency that the 15-inch driver can reproduce.

Most 15-inch drivers give up at 2,000 to 3,000 Hz, so the Soundsphere design places a group of special high-frequency drivers, evenly distributed on the surface of the sphere, to continue to radiate sound omnidirectionally to the highest audible frequency: 20,000 Hz (wavelength = $\frac{1}{2}$ inch). The result may not be perfect, but, considered broadly, the Soundsphere is the only truly omnidirectional speaker available to the professional market.



Loudspeaker configuration above Ring Three. (An identical configuration appears above Ring One.)

OMNIDIRECTIONAL RADIATION

Going back to state-of-the-art principle number six, it would appear that the last thing anyone should do is introduce an omnidirectional loudspeaker into an arena. After all, what good does it do to spray sound, intended for the audience, up to the rafters? In attempting to answer this question we admit to conjecture. Our only defense is that the system under discussion has consistently outperformed the existing arena cluster in city after city. Indeed, the sound quality seems to be independent of the environment; essentially the same in Miami, Baltimore, Boston or New York.

Directional speakers are thought to be beneficial because they steer the sound into the audience where it will be heard and quickly absorbed. If most of the energy is absorbed on the first bounce, theory has it, then less will be available to cause reverberation. This may be true, but it is also possible that directional speakers only prolong the inevitable. Eventually the hall will be filled with *some* kind of reverberation.

Directional speakers, such as in a central horn cluster, are very good at controlling the higher frequencies. But below 500 Hz, where the large bass bins take over, they lose control and at the lowest frequencies, as explained earlier, become omnidirectional. The reverberation therefore has a tonal character that is different from the original sound first emitted.

Now consider the frequencies from 500 Hz on up which are efficiently punched (always did love that word) by a horn cluster, into the audience. Remember that a two-foot surface is an obstacle, and therefore a reflector of sound at 500 Hz and that a six-inch surface can be a reflector at 2,000 Hz.

In arenas, at least, audience areas are rarely completely absorptive. Concrete aisles, stairs, balcony edges and small sections of hard wall are all present to reflect some of this high-energy sound back into the hall. Considered on the average, these reflections are strong, few and far between, and contribute to the reverberation at a much later time than the omnidirectional low frequencies which were allowed to diffuse much sooner and in a much more even manner.

By contrast, an omnidirectional speaker fills the hall with all frequencies in the quickest possible time and it therefore is reasonable to assume that the reverberation will be smoother, denser, more diffuse and have a better frequency balance.

Is reverberation harmful? Not at all. To most people it is desirable, like a chorus of angels reaffirming what has been uttered. But it should be just that—a chorus—not a few cranky spirits moeking every word.

To create reverberation, recording studios are usually equipped with the best reverberation devices that money can buy. The cost of these devices is in direct proportion to the density, smoothness and lack of coloration that can be achieved. No recording engineer has ever been able to destroy the intelligibility of a lead vocal by applying too much of this type of reverberation.

In a performing space, reflected sound can and often does make hearing difficult. If a loudspeaker utters the word "shot gun," the word "shot" careens around the room at 770 miles per hour and arrives back at the listener just in time to interfere with the word "gun." (Say what?) Now picture a man, standing just to your left, reciting Lincoln's Gettysburg Address and a man on your right reading from the Guinness Book of World Records. If you choose to listen to the Gettysburg Address, the man on your right is definitely an annoyance. If he is replaced by a steady tone of equal loudness, it is easy to understand the man on the left. A steady tone contains little information but if it is interrupted in the form of Morse code, Dante's Divine Comedy can be imparted to someone who can read the code.

The point is that it is the amount, and not the loudness, of information contained in the reverberation that produces the annoyance. Dense, smoothly decaying reverberation, with a tonal character similar to the sound which originally caused it, contains less information and causes less annoyance. This may explain why, in experience with these systems so far, the omnidirectional speaker is never less intelligible than the existing horn cluster and often is more intelligible.

The Ringling Circus has ten speakers spaced along the overhead truss that travels with the show. By the time the truss goes up, the 22-inch spheres are barely noticeable. For the circus, this is especially important since aerialists perform in this area. An additional advantage is that an omnidirectional speaker does not have to be aimed. Considering the speed with which the circus loads in, this is a big plus.

The maximum power delivered to each speaker is 100 watts, therefore, at maximum, the system operates on 1,000 watts, a modest amount by today's standards. Sound levels in the arena average 90 dBC. This may not seem loud, but it is. The reason for this is multiple sourcing.

MULTIPLE SOURCES

The direct sound (before reverberation) is delivered to any given seat by all ten speakers at once. Actually, the sound from each speaker arrives at a slightly different time, but all are heard from within 50 milliseconds, which is within the integration time of the human hearing system. Therefore, the listener perceives a single sound (albeit a fat one). Since loudness is a subjective quality and not necessarily measurable on a sound level meter, 90 dB from multiple sources can sound much louder than 90 dB from a single point. At any rate, 1,000 watts of amplifier power has produced more than enough loudness for any arena yet encountered.

Multiple sourcing produces another benefit for a largely visual show such as the Circus. There is a lessened ability to identify the location of the sound source. Thus the imagination is free to connect the sound to the visual event. When the band strikes up it is not perched on the truss like an aural albatross, but is simply *there*, generating a good time for everyone.

SOUND ENGINEERING

Having achieved what we felt was a better synergy of sound and visual effect, attention was turned to the sound engineer and his role in the creative process of live theatre.

You may have seen the sound engineer at the last concert you went to. He's the one standing behind the 20- or 30-channel board wearing sunglasses. When the music starts he gets very busy. If you ask him what he is doing he will tell you that he is "getting a sound," as if the sound did not already exist. His job is not an easy one.



The microphone set-up, employing several PZM mics mounted on plexiglass disks, for the Ringling Bros. orchestra.

At some point, usually during a sixteen-bar rest for the trombones, somebody comes up and yells, "I can't hear the trombones." OK—up come the trombone pots 1 point. The trombones finish their rest and come in like the horns of the apocalypse. "You're losing the drums," yells the advisor. "Omigod—losing the drums!" There are 14 drum mics so they have been assigned to a submaster. Up goes the sub, 2 points. "A little more bass!" Raise the bass guitar 1 point and give it 5 more dB at 100 Hz, just in case he meant the *bass* of the bass.

By now the peak lights on the board are lit like so many solid-state Indian campfires on the horizon. "Wadda ya think?" screams the engineer. "Well I don't know...it lacks punch!" "Louder" yells someone in the audience. "OK!...*punch!*? You want punch?" He knows what to do to get punch, run anything with an edge on it through a resonant circuit. "How's it now?" "Fine, but I can't hear the trombones!" (Of course not. The trombones, surprised by their last entrance, have backed off from the mics.) Up come the bone pots 1 point along with some boost at 500 for tone and 3k for more edge. On their next entrance, the trombone players back up again before they have finished the riff they're playing. There is a lot of drum leakage starting to come through on the bone mics. The cymbals certainly do have an edge on them; they sound strangely like... a trombone!

This man suffers from one of the new diseases of the technological age known as *black box syndrome*—a feeling of guilt that one has not used every processor at his command to make an improvement or cure a problem. Black box syndrome clouds a man's mind and prevents him from reasoning as follows:

"The trombone is a marvelous instrument. It took skilled craftsmen 500 years to develop that sound. Those players up there are professionals who have bought the best trombones they could find. Who am I to *fix* their sound?"

No, a man with a black box is never humble. Power, as the saying goes, corrupts.

We started by asking: what of the musician? Is he henceforth and forever going to lose control of his own music? Perhaps, once again, it was the Circus atmosphere that gave us the inspiration to see beyond the black box syndrome.

American composer Charles Ives once asked, "My God, what has sound got to do with music?" We couldn't agree more. If the sound man wants to be a musician, let him take up the guitar. In this type of show the sound man should provide an artful blend of music, dialogue and effects and relate this blend, through level changes if necessary, to the audience and the performer. To free him for this task, we created what we came to call the automatic PZM™ orchestra.

MIKING THE BAND

A PZM microphone was attached to each music stand for trombones, trumpets and saxes. Drums were miked with a PZM on the floor near the kick drum and a second PZM was

mounted to a clear plastic disc and suspended three feet over the drum kit. Similar discs were provided for solo trumpet, sound effects, tympani, etc. Electric instruments were taken direct.

For those unfamiliar with the PZM or Pressure Zone Microphone®, it is essentially a very small condenser microphone mounted on a reflecting plate. While there is a whole body of evidence, theory, counter-theory and even mysticism as to just how it operates, we will ignore that here because our main reason for selecting this microphone was simply because it did not *look* like a microphone. Most microphones are long and phallic and *point* somewhere. A musician therefore feels that he must *point* his instrument at it or he will not be heard.

The lack of a focal point, we have found, is a psychological release and the average trumpet player, let us say, sits back, relaxes, and plays his heart out. After all, the omnidirectional speakers deliver the same sound to the musician as to the audience so he *knows* how he sounds to everyone.

Being small and basically nondirectional, the PZM microphone produces little or no off-axis coloration, as occurs with larger directional microphones. This means that if a musician moves around a little it does not matter; the tonal character of his sound doesn't change. Attaching the mic to the music stand has several benefits. First, the sheet music tray provides an additional reflecting surface for the microphone. Also, because a musician will always tend to orient himself in a certain way to the sheet music, he will automatically be consistent in his relationship to the microphone. Finally, the average distance from source to microphone works out to be two to three feet. At this distance, slight shifts in position do not perceptibly alter the the balance of the various instruments in the final mix.

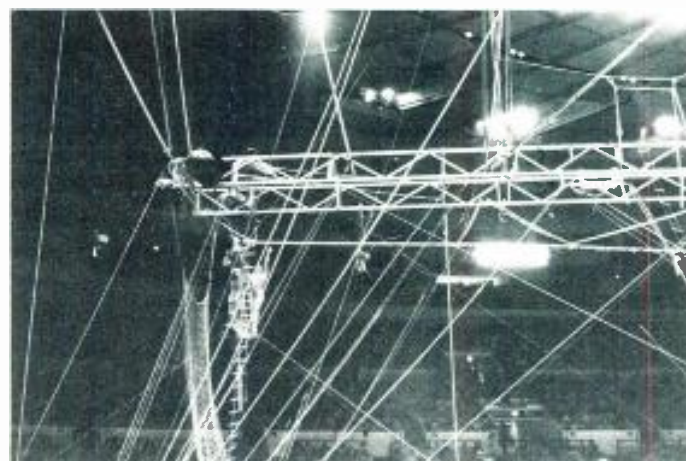

The loudspeaker array mounted at the end of the grid over Ring One.

The technique just described results in a band balance that requires little if any attention by the sound man. On opening night in a new arena the balance may be a little ragged at first, but if the sound man resists the temptation to make adjustments, the band soon finds a groove and delivers to the sound man exactly what he needs to work with. On the console there is a sub-master control marked "band." This is the control that is used, along with similar controls for dialogue, effects, etc., to create a total sound picture. The 300 or so controls on the left side of the board which have to do with the individual adjustment of each instrument have been locked down as far as possible, and are rarely touched. On the Circus, the only attention required is the occasional application of a feather duster to remove elephant dust.

If all of this seems like an over-simplification of very important technical problems, we can only suggest that you take in Ringling Brothers and Barnum & Bailey Circus when it comes to town. We hope you don't notice the sound. Instead, we hope that you fall in love with Nelly Ivanov when she dangles by one foot from a motorcycle 50 feet over... well we don't want to give it *all* away. ■

Recording Studio Rentals—or—You Don't Have to Own Florida to Enjoy It

When the client wants everything, don't panic, rent!

“**W** E WANT TO BOOK YOUR STUDIO for a mixing project that will take two weeks. Oh, by the way, you *do* have three Lexicon Digital Reverbs, two Eventide Harmonizers, a BTX Shadow lockup system, a couple of two-track half-inch recorders, 48 tracks of noise reduction, an Orban de-esser...

This story is a familiar one that studio owners and managers have heard many times.

Now, you've been thinking about getting some of these items for some time, but *all-at-once*? That's a lot of bucks to lay out up front for a project that may gross you from \$10,000 to \$12,000. If your cash flow could stand it, maybe it would be a good idea to buy it all, but, a few more deals like that would probably put you out of the studio business and into the disposal-of-used-equipment business. The solution in New York City, Hollywood or a few other recording centers is obvious. Call your favorite rental company, put a hold on the equipment and tell the group they've got a deal subject to some additional charges for the rentals.

"Great," you say, "but I'm not in mid-town Manhattan, I'm in Burlington, Vermont and the only rental outfit here has Rototillers, chain saws, party glasses and small PAs." No sweat. Pick up the phone and call the big city. The only difference in cost will be the transportation and handling and they will be delighted to have a new customer. The point is, the audio equipment rental business is a nationwide service, limited only by availability of truck and plane delivery. At any given time, a rental company may have an EMT reverb in Birmingham, Alabama, a 24-track MCI in Wilkesbarre, Pa., and a dozen other major pieces of pro audio equipment in as many cities across the country. Since most rentals are a cash deal, the size or location of the renter doesn't really matter.

At the end of this article is a listing of some of the major audio equipment rental firms in the U.S. Next time you're short

something new or exotic that could help you land or keep a good customer, give one of them a call. You will be pleasantly surprised at how interested they are in you and how helpful they can be.

THE AUDIO RENTAL BUSINESS...OR HOORAY FOR HOLLYWOOD!

In the film rental business, rentals have always been a way of life. Standard Hollywood procedure was to get a location, assemble the personnel and begin the production with tons of equipment, all rented. To this day, that hasn't changed much. It's a safe bet that nearly all the equipment you see on a film shoot—cameras, lights, audio recorders, generators, etc., is rented. As the audio recording industry began experiencing its explosive growth in the mid 60s, it was only natural that the studios looked to rent their gear. After all, most of the sound technicians had their start in the film business. And thus it followed that rental companies, specializing in audio equipment only, showed up on the scene.

Today, audio equipment rental is still a way of life in Hollywood. Many smaller studios rent at least some equipment for every session they have. Still others have carried it so far that their rate is based on a studio, control room, console and monitors, with everything else being an additional rental charge. Today there are more than a dozen rental companies in the Los Angeles area with an annual volume running into the millions. Allen Beyers, president of Hollywood's Audio Rents, says his firm specializes in outboard gear and prides itself on having the latest equipment. Audio Rents, largest in the West, has been owned by Beyers and veteran studio owner, Lottie Cammarata, since 1975.

New York City, where the emphasis was on audio recording rather than film, has been much slower to develop as a rental center. Audiotekniques established the first full time, audio-

only rental service in Manhattan in 1976, and today there are three or four other companies offering audio equipment, in addition to the film, video and instrument companies.

WHY RENT?

In the little scenario with our friend from Burlington, we covered the most basic reason for renting equipment: the client wants it! We are all in business to make money, and to do that we have to keep the client happy. Whether it's for an extra 24-track for a double-system lockup for a month, a pair of exotic limiters for a week, or a vocoder for a 30-second special effect, nine times out of ten your only solution is going to be a rental company. Sometimes the demand for the items develops during the original negotiations for the session. Other times it comes midway in the second week when the producer just has to have a Complex limiter to get his special effect. Whenever and wherever, it's the client request that usually dictates renting. As studio proprietors, your ability to satisfy these requests usually has a direct bearing on the length of your relationship with that client.



Would you rent a used fish from this man? Author Brosious (he's the one on the right) with a less-than-satisfied client.

EQUIPMENT BREAKDOWNS

When the PROMS in your SMPTE system suddenly decide to lock onto the HBO satellite instead of the video recorder to which it is assigned, it's time for a rental and a quick trip for the faulty gear to a service center for a checkout. (Keep the rental bill, because if your own gear is still in warranty, the manufacturer should pay the tab.) The availability of top-quality recording equipment for rent is a security blanket to help you out of sticky situations or as a fill-in for extra-heavy maintenance requirements.

NEW GEAR EVALUATION

Try it before you buy it! It would be great if every studio could get each new piece of equipment that comes along to try. But, as we know, it doesn't happen that way. The big studios like the Record Plant, Power Station, Village, A&R, Hit Factory, and Kendun get it first, and if they all approve and buy, everyone else is supposed to head for their dealers and demo it there. But you want to know how JBL Bi-Radials sound in *your* place. The dealer can't get a pair for you, schlep them to and from your studio, give you a good price and risk having a pair of scratched units on hand if you don't like what you hear. There's not enough profit in the sale for that and, strange as it may seem, dealers, just like you, are also in the business to make a profit. So, rent a pair, try them for a few days, and if you

decide to buy, get a credit for part of the rental towards the purchase price. Some rental companies are established equipment dealers.

SPECIAL PROJECTS

Your favorite client tells you that he won't be in for a while because he's thinking of getting some recording gear and working on stuff at home. Naturally, you would prefer to have him "work on his stuff" in the studio, but that's apparently out, so let's make some lemonade out of the lemon. Help him figure out just what he does need—eight-track half-inch recorder, small board, a two-track, monitors, etc. Work out a package with him and get a rental company to handle the deal. Offer to help him with the gear at home and promise to bail him out if he gets in trouble. In short, keep him in your stable and head him off at the pass before he becomes another former client. (I even know a studio that bought such a package which they make available to clients at attractive rates just to keep them from straying.)

THE RENTAL BUSINESS IS A SERVICE BUSINESS

Remember, the rental company is not doing you a special personal favor renting equipment to you. You are buying a service, and service is what you have a right to expect. Some of the services offered should include:

1. Published rates so that you know ahead of time exactly what you will be paying. Beware of low prices from firms not really in the rental business. Most established rental companies have competitively similar rates. The sweetness of a low price tastes bitter when the gig is blown because the equipment doesn't work and there is no one available to fix or replace it.

2. Equipment in good operating condition with a written indication of checkout prior to the rental. Serious rental companies have full-time technicians whose only responsibility is to make certain that the gear you've rented really works and to assist you should any malfunction occur. If the equipment you receive doesn't work, call the rental company right away. If you keep the gear for a week and then tell them that it never worked, you'd better not expect much sympathy.

3. Delivery service is offered by most rental companies, sometimes at no cost, but usually for a charge. When there is no charge, common sense will tell you that the delivery costs are built into the rental rate. If you are in one of the metropolitan areas, you may save some money by picking up and returning the gear yourself. Out of town, expect to pay for whatever delivery service you choose (UPS, Airborne, motor freight, etc.), plus a handling charge.

4. Advice and assistance. A good rental company will take the time to discuss projects with you and help you choose the equipment that is right for the job. They may even talk you out of something you request in favor of something else that might do the job a little better. For example, we have a specialist in BTX SMPTE systems who will tell you his recommendations for your project and, if necessary, will come to your location to help with the set up and initial operation. Other rental companies offer similar services. For example, Scharff Communications, New York City, is well-known for its expertise in film projects and freely assists their clients in that field.

5. Payment, when, and by whom? Unless you are a major user of rental equipment with credit established ahead of time, expect to pay for the whole rental when you make the arrangements. In addition, you will have to pay a deposit on the equipment which is refunded when the equipment is returned in good working condition. Make sure that all cables and manuals are returned with the equipment or expect to have a portion of your deposit applied to the shortages. Also, if the project is going to take longer than you anticipated, *please* call the rental company right away and tell them. Usually the equipment you have is scheduled out to another client on the same or next day after your anticipated return. If you suspect that the job may take longer, make certain that the rental company is willing and able to go along with the extra days.

When it comes to the question of who pays, that is up to you. Many studios are firm in holding to the rate quoted for the session based on the equipment that the studio owns and has available. When a client demands extras for his booking, his written OK for the rental charges should be requested. Competitiveness and size of the booking may dictate a moderating of that policy to a sharing of the rental expense between the client and studio. Again, that is up to you. Most major studios, when working with record labels, prefer to get a purchase order directly from the record company. Similarly, when some rental gear is requested in the middle of the booking, get a written approval of the additional billing from the producer. This is easy enough to get when the gear is needed for some special effect critical to the success of the project...easy, that is, if you get it right then and there...not so easy, sometimes, to present the bill when you are settling up and someone conveniently forgets that the request was made by the client.

In the metropolitan areas, rentals are a generally accepted part of business and clients expect to pay the bill. If you are out of town and have a project that is going to take some rentals,

check the prices and then make certain that the client understands his payment responsibility. When the rental is over, get the equipment back to the rental company immediately. If it's a short session, you can blow the profit by procrastinating and winding up with extra charges. It is a good idea to call the rental company and let them know that you have sent the equipment back and by what means.

FINAL TAKE

The equipment rental companies can be a powerful tool for you. If you are a small-to-medium-sized studio, the availability of sophisticated rental equipment can allow you to offer full service without the necessity of committing the capital funds which might be required. Larger studios are already familiar with rentals and use them regularly to supplement their already-high equipment inventories. We've listed a few of the many rental companies in the metropolitan areas. Give one of them a call and ask for a rate schedule and then reach for the phone the next time a problem comes up and you will find that problems quickly become opportunities for creative solutions. ■

Recording Equipment Rental Firms

New York City Area

Ace Sound Rental Company
387 Park Avenue South
New York City, NY 10016
(212) 685-3344

Audiotechniques Rentals
1619 Broadway
New York City, NY 10019
(212) 586-5989
Out Of State 1-800-223-2486

Camera Mart
456 West 55th Street
New York City, NY 10019
(212) 757-6977

Scharff Communications
1600 Broadway
New York City, NY 10019
(212) 582-7360

Select Audio Visual
115 West 31st Street
New York City, NY 10001
(212) 594-4450

MPCS
514 West 57th Street
New York City, NY 10019
(212) 586-3690

Los Angeles Area

Audio Affects
P.O. Box 6327
Beverly Hills, CA 90212
(213) 986-9902

Audio Engineering Associates
1029 North Allen Ave.
Pasadena, CA 91104
(213) 684-4461

Audio Rents

(213) 874-1000

Canyon Recorders
11941 Wilshire Blvd.
Los Angeles, CA 90025
(213) 479-4466

Moonbeam Productions
3263 Selby Ave.
Los Angeles, CA 90034
(213) 838-7368

Recording Services Co.
10824 Ventura Blvd.
Studio City, CA 91604
(213) 766-7191

San Francisco Area

Audio Video Rents
60 Broadway
San Francisco, CA 94111
(415) 781-2603

Chicago Area

Polycom Productions
201 East Erie
Chicago, IL 60611
(312) 337-6000

Denver Area

Davis Audio Visual
1801 Federal Blvd.
Denver, CO 80204
(303) 455-1122

Nashville Area

Digital Services Recording
1035 Draughon Ave.
Nashville, TN 37204
(615) 292-8130

Professional Audio Rentals
2808 Azalea Place
Nashville, TN 37204
(615) 297-0211

Sound System Design the Altec Way

*Yes, Virginia there is such a thing as Sound System Design.
Just be sure and bring along your personal computer.*

HOW DO YOU design a sound system? According to Altec Lansing's Ted Uzzle, there are at least four—and possibly more—ways to do the job. Uzzle, who doubles as Altec's manager, market development, and philosopher-in-residence, was in town recently to help conduct another of his company's Sound System Design Seminars.

Actually, the Altec crew was *out-of-town* recently, for the seminar was held at the Sheraton Hotel, overlooking scenic Newark Airport.

First things first: The Sheraton-Newark may be the only hotel in the world that does not have a coffee shop. Instead, there is Daphne's, an elegant watering hole where dining is serious business indeed. No fast foods here, and I suspect that anyone foolish enough to ask for a light snack would be escorted to the door and advised to catch a plane for Chicago. This left at least some seminar participants—long accustomed

to airport catering by Raoul of Calcutta—in a state of culture shock.

Another form of shock awaited those seminar participants (your reporter, for instance) who had always suspected that "Sound System" and "design" were mutually-exclusive terms. (This comes from listening to P.A. systems at airports.) Each attendee was handed a 2-inch thick notebook full of charts, tables, calculator programs, graph paper and other fun stuff that gave every indication that this was going to be two days-worth of hard work.

Uzzle's first four ways of designing sound systems were disposed of quickly, and then the seminar got down to the fifth way. For the benefit of scholarship, methods 1 through 4 are presented here, in their entirety, as FIGURES 1-4. (Possibly, yet another **db** first.)

Method 5 can't be presented in anywhere near its entirety, since it involves a lot of that stuff in the 2-inch binder, along

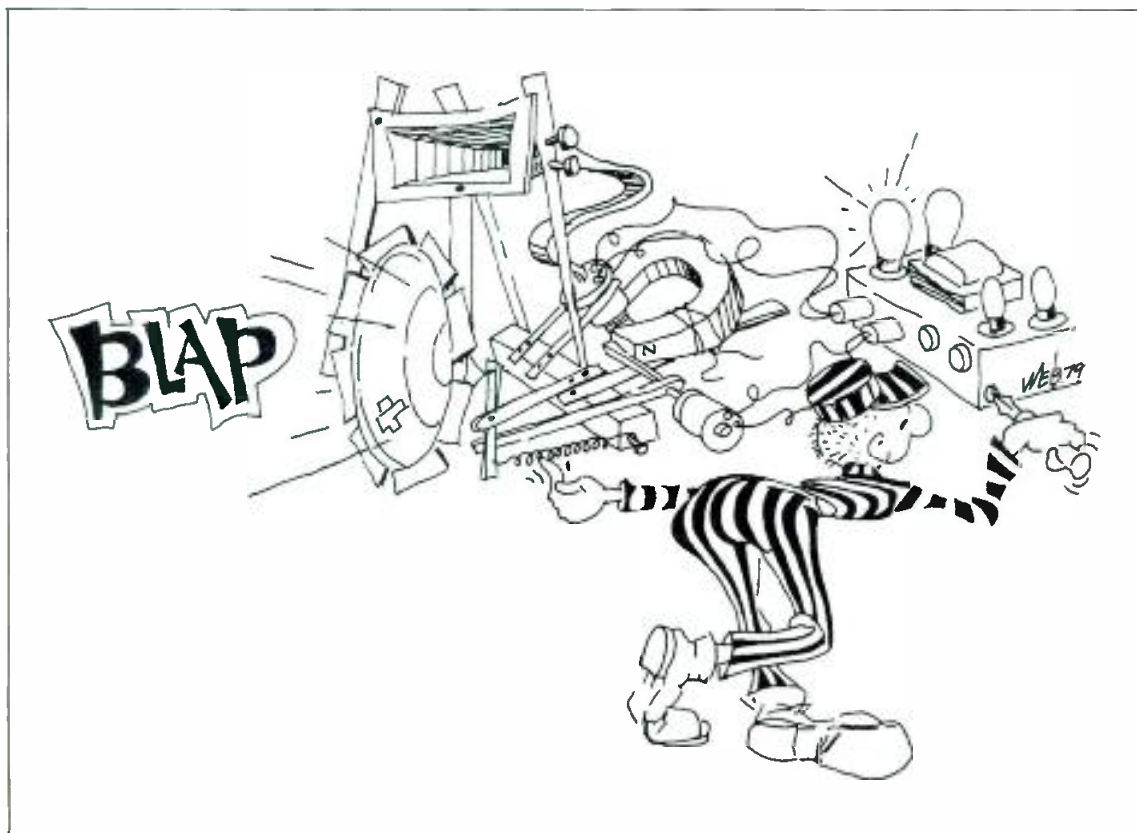

*Method 1: Simply connect anything lying around,
and adjust it.*



Method 2: Use lots of math. Then make a guess at it.

$$p_{\omega} \simeq -\frac{ik\rho c}{2\pi} \int_0^{2\pi} d\phi_0 \int_0^{1/a} d\mu \int_0^a u_{\omega}(w_0, \phi_0) w_0 dw_0 = -\frac{1}{2} i \rho c k a \langle u_{\omega} \rangle \quad ka \ll 1$$

where

$$\langle u_{\omega} \rangle = \frac{S_{\omega}}{\pi a^2} = \frac{1}{\pi a^2} \int_0^{2\pi} d\phi_0 \int_0^a u_{\omega}(w_0, \phi_0) w_0 dw_0$$

Method 3: Use lots of math. This question may mean something. Then again, it may not.

with the use of a Hewlett-Packard HP-41 calculator, or the equivalent (if there is one). This seemingly harmless little gadget can be loaded with some two dozen programs to help the sound-system designer find the answers to such timeless questions as:

- Will it be loud enough?
- Will it be intelligible?
- Will it feed back?

Needless to say, the Altec library of calculator programs can't be reproduced here, given our space limitations. However, we can pass along some excerpts from one of the technical papers, plus our own BASIC computer program, which is based on the calculations given for measuring Thiele-Small loudspeaker parameters.

The purpose of this little exercise is to show that the previously-tedious task of calculating these or similar parameters need no longer be considered beyond the reach of the system designer who does not happen to have a Ph.D. in math. System-design calculations that used to take hours can now be done in seconds, by anyone with access to a programmable calculator or personal computer.

It should be noted here that the Altec seminar series is not intended to be an entry-level course in sound-system design (as your reporter quickly discovered when much of the information went sailing by, far overhead). Rather, it is a means of disseminating in-house engineering information to sound contractors and acoustical consultants who are already well-versed in the basic theory and practice of their craft. The student in search of fundamental concepts in audio and acoustics would be better off enrolling in a course such as the popular Syn-Aud-Con seminars and workshops that are frequently offered around the country. (See db calendar.) Be warned though: there's no escaping Hewlett-Packard, even at a Syn-Aud-Con seminar, where HP-41s are as taken for granted as pencil and paper.

MEASURING THIELE-SMALL PARAMETERS

As pointed out in the Altec literature, the ability to measure

basic loudspeaker parameters can be a useful tool, not only in the hands of a loudspeaker design engineer, but also for the sound contractor, consultant, and even the customer. Performance of existing or proposed speaker systems can be predicted and checked to see if they will meet a specific design criterion. The important small-signal parameters can be found quickly, and with reasonable accuracy.

The essential parameters can be measured with the test equipment seen in FIGURE 5. Before connecting the measure its voice-coil resistance, R_e , being careful not to include any test-lead resistance in the measurement.

To begin the free-air tests, the cone of the loudspeaker should be in the vertical plane, and can be suspended with a cord or strap. An area of at least three feet surrounding the speaker should be kept free from obstructions and any movement.

With the loudspeaker in the test circuit, set the signal generator at 500 Hz, and adjust the output level until meter I_a is between 10 and 20 volts. The scope pattern should be an ellipse.

To find the free-air resonance, f_s , sweep the signal generator downwards until I_b reaches a maximum reading. The CRO should display a straight vertical line at its maximum amplitude. Note the frequency, and the voltages on I_a and I_b .

This data is entered into the computer program in order to calculate the voice-coil impedance, R_e , at the resonant frequency, and the geometric-mean impedance, R_l . Next, to find the lower and upper frequencies at which the voice-coil

RTW Peak Meter



**Stereo Peak Program Meter
Model 1206**

- 101 segment display permits precise peak level metering
- Automatic ON/OFF switching dependent on signal presence
- Auxiliary input for full scale metering of low level inputs

Available exclusively through



auditronics, inc.
3750 Old Getwell Rd.
Memphis, TN 38118, USA
Tel.: (901) 362-1350
Telex: 533356

impedance will equal R_1 , first sweep the generator downwards until V_b reaches the value indicated by the computer, and then note the new value of V_a read on the meter.

The value for V_b is now calculated, in order to satisfy the ratio, $V_b/V_a = R_1/R$. (R is the 1000-ohm resistance seen in FIGURE 5.) If the calculated value does not closely match the observed value, the signal generator should be fine-tuned to the new value for V_b , as specified by the computer. These steps are repeated, as required, until the observed values of V_b and V_a match the R_1/R ratio.

The program then calculates the approximate value of the upper frequency, f_2 , and the signal generator is tuned to this frequency. Again, V_a and V_b are noted, and the generator is fine-tuned as required to satisfy the ratio mentioned above.

Using the following equations, the program calculates the speaker's total, Q (Q_{ts}), at the resonant frequency, as well as the mechanical, Q (Q_{ms}), and the electrical, Q (Q_{es}).

This concludes the free-air measurements. The speaker is now mounted to a test box of known volume. This enclosure should have no dampening material such as fiberglass or felt inside, and it is extremely important that the box be air-tight.

The procedure given above is now repeated, and new values are calculated for Q_{ts} , Q_{ms} , and Q_{es} .

Finally, the program calculates the volume of air, V_{as} , which has the same acoustic compliance as the driver, and concludes by finding the speaker's reference efficiency. ■



Method 4: If all else fails, go to sleep. The design will come to you in a dream.

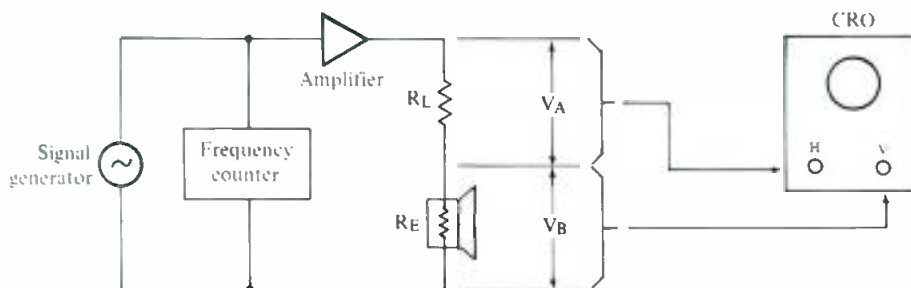

Figure 5: The test setup required for measuring Thiele-Small parameters.

DESIGNING SOUND SYSTEMS

The measured values for the voice-coil resistance, resonant frequency, V_a and V_b are entered (130-200), and the program calculates and displays R_e and R_1 (210-280).

The computer "guesses" at a likely value for V_a which will be observed at the frequencies at which the voice-coil impedance equals R_1 (300). Based on this guess, V_b is calculated (310), and the program enters a FOR...NEXT loop (340-490) in which the user is first asked to enter the lower frequency at which the meter V_b displays this calculated value (360-430). In tuning to this frequency, presumably V_a varies slightly from the computer's "guesstimate," and its new value is entered (450). V_b is again calculated (460), and compared with the earlier value (470).

If the two values differ by more than 0.01 volt, the program branches to line 770, and the new V_b value is substituted for the old. The display of the lower frequency is erased (770-800), and the user is asked to enter the new lower frequency which satisfies the new value for V_b (830-840 & 370-420). This segment of the program repeats, until the values for V_a and V_b satisfy the R_1/R ratio (460-470).

Once the V_a/V_b ratio is correct, the final value for f_1 remains as entered on line 430, the program loops back (490-to-340) and the procedure repeats for f_2 . To aid in tuning the signal generator to f_2 , the program calculates and displays its approximate value (410).

When f_2 has been entered, the program calculates and displays the three Q values (510-650). Next, line 660

sends the program to a sub-routine which instructs the user to mount the speaker on a test box, and enter the box's volume (850-920). The sub-routine returns to line 670, and the next set of parameters are calculated and displayed, as lines 140-670 are repeated.

The program concludes by calculating and displaying V_a (680-710) and the reference efficiency (720-750).

PROGRAM CHECK

To verify that the program works, enter the following values on the line numbers indicated.

- 130 6.4 The voice-coil resistance, R_c .
- 160 27.2 The resonant frequency, f_s .
- 180 11.2 V_a at the resonant frequency.
- 200 2.23 V_b at the resonant frequency.

The program will now calculate and display:
 $R_t = 197.35$ and $R_l = 35.54$. Continue by entering:

- 430 18.4 The lower frequency, f_1 .
- 450 13.41 The observed value of V_a .
- 430 39.5 The upper frequency, f_2 .
- 450 13.41 The observed value of V_b .

The program will now calculate and display:

- $Q_{ts} = 0.23$ (The total Q),
- $Q_{ms} = 7.16$ (The speaker's mechanical Q),
- $Q_{es} = 0.24$ (The speaker's electrical Q).

Next, enter:

- 900 4 The test box volume. The program now repeats the procedure.

The next set of entries, and the program calculations are:

- 160 54.6
- 180 11.96
- 200 1.64
- $R_0 = 137.12$
- $R_1 = 29.62$
- 430 44.3
- 450 13.48
- 430 66.9
- 450 13.48
- $Q_{ts} = 0.52$
- $Q_{ms} = 11.18$
- $Q_{es} = 0.55$.
- $V_{as} = 14.32$
- $Eff = 3.28$.

The program presented here was written on an IBM Personal Computer, and with minor modifications should run on an Apple or Radio Shack, or other personal computer. The PRINT USING "###.##" part of some of the PRINT statements should be ignored by Apple II users. Lines 350 & 770-810 may also be ignored, since their only purpose is to erase entries of f_1 and f_2 , when these values must be re-entered.

The program is based on Altec Technical Letter 268, "Measuring Thiele-Small Parameters" and the values given in the Program Check sections are as found in Altec Lansing Calculator Program CP-21A.

```

100 CLS
110 PRINT "THIELE-SMALL PARAMETERS"
120 R = 1000
130 INPUT "          ENTER THE VOICE-COIL RESISTANCE: RE = ",RE

140 FOR K = 1 TO 2
150   PRINT
160   INPUT "          ENTER THE RESONANT FREQUENCY: FS = ",FS(K)
170   PRINT
180   INPUT "          ENTER VA AT THE RESONANT FREQUENCY: VA = ",VA
190   PRINT
200   INPUT "          ENTER VB AT THE RESONANT FREQUENCY: VB = ",VB
210   RO = R * VB/VA
220   R1 = SQR(RE * RO)
230   PRINT
240   PRINT USING "          THE VOICE-COIL IMPEDANCE AT FS IS: RO  ";
250   PRINT USING "#####";RO
260   PRINT
270   PRINT "          THE GEOMETRIC-MEAN IMPEDANCE AT FS IS: R1  ";
280   PRINT USING "#####";R1
290   PRINT
300   S = VA + VB
310   VB1 = S * R1/R
320   FS(1) = "LOWER"
330   FS(2) = "UPPER"

340 FOR F = 1 TO 2
350   V = CSRLIN
360   PRINT "          ENTER THE ";
370   PRINT FS(F);" FREQUENCY, F";USING "###.F";
380   PRINT " AT, "
390   PRINT "          WHICH VB IS EQUAL TO ";USING "###.##";F;
400   PRINT " VOLTS";
410   IF F = 2 THEN PRINT " ";PRINT "          (F2 SHOULD BE ABOUT";
420   INT(FS(K)*2/F(1));"HZ."
430   PRINT " ";F";USING "###.F";
440   INPUT INPUT " = ",F(F)
450   PRINT
460   INPUT "          NOTE VA, AND ENTER THE VALUE: VA = ",VA
470   VB2 = VA * R1/R
480   IF ABS (VB1 - VB2) > .01 THEN GOTO 770
490   PRINT
500   PRINT
510   QT(K) = SQR(RE/RO) * (FS(K)/(F(2) - F(1)))
520   QM(K) = QT(K) * RO/RE
530   QE(K) = QM(K)/(RO/RE - 1)
540   PRINT "QT";USING "###.##";K;
550   PRINT " = ";
560   PRINT USING "###.##";QT(K);
570   PRINT " (THE TOTAL Q AT AN FS OF";F(K);"HZ.)"
580   PRINT "QM";USING "###.##";K;
590   PRINT " = ";
600   PRINT USING "###.##";QM(K);
610   PRINT " (THE SPEAKER'S MECHANICAL Q.)"
620   PRINT "QE";USING "###.##";K;
630   PRINT " = ";
640   PRINT USING "###.##";QE(K);
650   PRINT " (THE SPEAKER'S ELECTRICAL Q.)"
660   IF K = 1 THEN GOSUB 850
670   NEXT K

680   VAS = TB * (FS(2) * QE(2)/(FS(1) * QE(1)) - 1)
690   PRINT "VAS = ";
700   PRINT USING "###.##";VAS;
710   PRINT " (VOLUME OF AIR WITH SAME ACOUSTIC COMPLIANCE
AS DRIVER.)"
720   N = 100 * 2.73E-08 * (FS(1)+3 * VAS/QE(1))
730   PRINT "EFF = ";
740   PRINT USING "###.##";N;
750   PRINT " (REFERENCE EFFICIENCY.)"
760   END

770   VB1 = VB2
780   LOCATE V, 1
790   FOR X = 1 TO 5
800     PRINT TAB(80)""
810   NEXT X
820   LOCATE V, 1
830   PRINT "          ENTER THE NEW ";
840   GOTO 300

850   PRINT
860   PRINT
870   PRINT "MOUNT THE SPEAKER ON THE TEST BOX, AND REPEAT
THE CALCULATIONS."
880   INPUT "WHEN READY, PRESS /RTN/ TO CONTINUE.":RS
890   CLS
900   INPUT "          ENTER THE VOLUME OF THE TEST BOX: TB = ",TB
910   PRINT
920   RETURN

```

RECORDING CONSOLE



• Audioarts Engineering will feature its new R-16 16-track modular recording console at the upcoming Audio Engineering Society Convention in Anaheim, California. Standard features include: semi-parametric equalization, phantom

power, and mixdown subgrouping. The unit has a 24-track monitoring option and can be configured to meet the needs of the individual user.

*Mfr: Audioarts Engineering
Circle 39 on Reader Service Card*

AUTOMATIC DISTORTION ANALYZER



• The AA 501 Option 02 Distortion Analyzer offers, in the same unit, intermodulation distortion techniques, noise measurements in accordance with CCIR recommendation 468-2 or DIN 45405, and harmonic distortion analyzer measurement capability. The AA 501 Option 02 incorporates features of the standard AA 501 as well as the enhanced measurement capabilities of the AA 501 Option 01. Features unique to the AA501 Option 02 include a quasi-peak detector in addition to the standard true rms detector, a 22.4 Hz to 22.4 kHz bandwidth limiting filter for unweighted measurement response and a CCIR weighting psophometric filter (functional only with quasi-peak detector). The digital voltmeter portion of the AA 501-02 is auto ranging on all scales, from the lowest 200 μ V full scale, to the highest 200 V full scale. Other features of the AA 501 Option 02 include: SMPTE, DIN or CCIR difference tone IM distortion measurement capability and 200 μ V full scale ac voltage range. The AA 501 Option 02 is packaged as a plug-in compatible with both Tektronix TM 500 and the new TM 5000 Series power modules. Thus the AA 501 Option 02 can be readily combined in a single package with the user's choice from over 50 manual and automated plug-in test and measurement instruments. Modularity also permits remote-testing—such as a studio transmitter link with only one oscillator.

*Mfr: Tektronix
Price: \$2,950.00
Circle 40 on Reader Service Card*

PRO-GRAPH PROGRAMMABLE GRAPHIC EQUALIZER



- 64 PROGRAM MEMORY CAPACITY
- 105dB GUARANTEED S/N
- REMOTE CONTROLLABLE
- 16 BANDS @ 2/3 OCTAVE SPACING
- BALANCED INPUTS & OUTPUTS
- VARIABLE INTENSITY SCREEN
- ± 14 dB CUT & BOOST RANGE
- MASTER/SLAVE LINKABLE

Design response curves, store them in memory, recall and display them instantly with precise repeatability--and all at the touch of a button. Free color brochure upon request.

polyfusion INC

92 Benbro Drive
Buffalo, NY 14225
(716) 681-3040

Circle 52 on Reader Service Card

Now! A balanced high-level output oscillator with the lowest distortion.

This is oscillator performance that's totally advanced, totally Tektronix! Depend on the new SG 505 Option 2 for balanced, high level output in the studio or at a transmitter site. It outputs a sine wave with less than 0.0008% THD, the lowest residual distortion of any oscillator on the market today.

Complex measurements are made automatically in tandem with the AA 501 Distortion Analyzer. These two TM 500 plug-ins can be mounted in the same or separate mainframes, or transferred to a portable mainframe for use in the field.

No other manufacturer offers this kind of flexibility: two separate devices that make one powerful package, side-by-side or miles apart. Still fully automatic, even when separated.

New state-of-the-art performance, by every measure! The SG 505 Option 2 features a completely balanced output configuration for compatibility with highest-performance audio systems. Source impedances are selectable among 600, 150 and 50 ohms. And when you're testing for clipping



margin or headroom, the SG 505 generates high level output of +28 dBm into a 600 ohm load and +30 dBm into a 150 ohm load.

Answers come quickly with the AA 501. No level setting, tuning or nulling required. Measurements are precalculated via digital processing and displayed on the LED readout automatically.

Part of the family: TM 500. These two plug-ins share the configurability that TM 500

is famous for: over 35 different plug-ins for a host of test and measurement requirements. Six mainframes provide bench, rackmount and portable packaging, each with built-in power supply.

Call the Tektronix National Marketing Center today for specifications, pricing and applications information. Technical personnel can answer your questions, accept your order and expedite delivery. Direct orders

include operating manuals, 15-day return policy, full Tektronix warranty and service back-up.

**Order toll free:
1-800-426-2200**

Ask for Dept. M3041
(In the State of Washington, call 1-253-5353 collect.)

**The Answer
By Any
Measure**

The Affordable

Digital Real Time Third-Octave Spectrum Analyzer

- Full 30 Bands • Six Memories • Quartz Controlled "Switched Capacitive Filtering" to eliminate drift • Ruggedized for Road Use • Microprocessor Controlled • Built-in Pink Noise Source • "Flat," "A," or "User Defined" Weighted Curves may be employed
- ROM User Curves Available.



MODEL 30
Affordable at just **\$1695.00**

GOLD LINE

P.O. Box 115 • West Redding, CT 06896
(203) 938-2588

SEND FOR COMPLETE LITERATURE:

NAME _____
COMPANY _____
STREET _____
CITY _____
STATE _____ ZIP _____

Circle 37 on Reader Service Card

OPTIMOD-AM



• Orban Associates has announced the second generation Optimod-AM, model 9100A. Two versions are available: the 9100A 1 Mono (Convertible to stereo) and the 9100A 2 Sum-and-difference stereo. The mono unit is converted to stereo by simply plugging in additional circuit cards. Some of the improvements in the 9100A over its predecessor, Model 9000A, are: a new six-band limiter with a distortion-cancelled multiband clipper which, together, yield at least a 3 dB increase in RMS modulation levels; improved transmitter equalizer with four sets of adjustments available; 25 dB of headroom; outputs for two transmitters, and smooth gated gain-riding AGC at the system front-end.

Mfr: Orban Associates, Inc.

Price: 9100A 1 (Mono) \$4395.00;

9100A 2 (Stereo) \$5295.00

Circle 35 on Reader Service Card

AUDIO DISTORTION METER

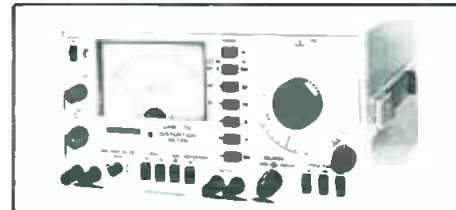

• The Model LDM-170 Audio Distribution Meter measures distortion, signal-to-noise ratio and signal levels for audio equipment and systems. Total distortion measurements of 0.01 to 100 percent can be made over a frequency range of 20 Hz to 20 kHz. Signal-to-noise ratio measurements can be made up to 70 dB with signal levels from 0.35 to 30 Vrms. Audio level measurements from 100 μ V to 300 Vrms can be made up to 200 kHz with plus or minus five percent full-scale accuracy. The LDM-170 comes with test cable, dual banana plug to alligator clips and instruction manual. While normally supplied for 115 Vac operation, it also is available for 100 or 230 Vac.

Mfr: Leader Instruments Corp.

Circle 41 on Reader Service Card

LOUDNESS MONITOR



• The Dorrrough Loudness Monitor is a program level that accurately defines the energy content of the audio waveform. The meter offers an operator-controlled solution to the problem of inconsistent loudness that results in the varying discrepancies of the end product as seen in TV, recording, and radio broadcast. The meter features a dual function on a single LED display. An LED bargraph shows normally weighted persistence material which the operator is directed to hold at center 0 dB, and a dot mode for peak indication which has a normal operator range at the +12 dB scale to the left. These two separate points of reference are discernable to the operator at all times.

Mfr: Dorrrough Electronics

Price: \$465.00

Circle 36 on Reader Service Card

PUERTO RICO

Announces the birth
of a brand new baby:

Name: *Crescendo*

Vital Statistics: 24 track
in-house and remote recordings
• LEDE™ control rooms • High
speed film mixing in 16mm and
35mm • Complete scoring facilities.



Crescendo
Audio Productions

Tel: (809) 792-1970

707 Calle Constitucion
Puerto Nuevo
Puerto Rico 00920

Circle 50 on Reader Service Card

PRO SOUND BROCHURES

• Cerwin-Vega has announced the publication and distribution of two brochures covering Cerwin-Vega loudspeaker systems. The "Sound Reinforcement" brochure includes descriptions, specifications and photos of fourteen Cerwin-Vega sound reinforcement loudspeaker systems. The products covered are primarily used for sound reinforcement in live musical performance situations. Products range from 3-way, full-range component systems to stage monitors, and include a number of vocal columns. The "Playback Systems" brochure features complete descriptions, specifications and photos of twelve systems primarily used in playback of prerecorded music material. Products range from full-range component systems to separate, high, midrange and bass component cabinets, and include single cabinet, full-range systems. Each of the new brochures also provide simplified diagrams and layouts showing how various component systems should be wired and amplified. **Mfr: Cerwin-Vega, 12250 Montague St., Arleta, CA 91331.**

ANNUAL REVIEW

• The 1982 edition of the Consumer Electronics Annual Review is a definitive guide to production and sales statistics for the major consumer electronics products during the last decade. It also provides important information on recent marketing developments and product trends. Two pages in the Annual Review provide a catalog of pamphlets, books and films provided for the consumer and the trade by the EIA Consumer Electronics Group. The origin and history of consumer electronics plus a chronology of industry highlights appear in the back of the booklet, which also has a history of the industry's allied trade associations. **Mfr: EIA/Consumer Electronics Group, 2001 Eye St., N.W., Washington, D.C. 20006.**

CATALOG OF TEST ACCESSORIES

• The 1982 Pomona Electronics Catalog is a 108-page booklet of test accessories used in electronic equipment. It includes over 450 black and white photographs and 30 drawings of such test accessories as banana plugs, jacks and patch cords; phone tip jacks, plugs and connecting cords; test clips, probes and holders, binding posts, black boxes and sockets. Also included in the catalog is an order form for special request quotations; assembly procedures for BNC and triaxial cables; metric and temperature conversion charts; cable and wire description charts, and electrical data. **Mfr: IIT Pomona Electronics, 1500 E. Ninth St., Box 2767, Pomona, CA 91769.**

ELECTRONIC WIRE/CABLE CATALOG

• Belden Corporation's Electronic Division's Electronic Wire and Cable Catalog (No. 882) is a comprehensive source of cable information and products for data communications, instrumentation, broadcast, computer and other electronic applications. The new catalog describes standard product lines in ten individually indexed categories: multi-conductor cables; computer cables; molded cable assemblies; fiber optic cables; coaxial and broadcast cables; plenum cables; high temperature cables; hook-up wire; cords and portable cordage, and convenience packaged wire and cable products. There are also listings for new computer cables for local area networks; expanded video cable lines; computer cable lines, and coaxial cables now certified to MIL-C-17E. Construction details are provided, as well as physical specifications and electrical characteristics in both conventional and metric units. Compliance with applicable UL, CSA, and related requirements is indicated. **Mfr: Belden Corp., 2000 S. Batavia Ave., Geneva, IL 60134.**

APPLICATION NOTE

• "The Fundamentals of Signal Analysis," subject of a new Hewlett-Packard application note, is a primer on the advantages of frequency and model analysis of electrical signals. Application Note 243 is a 58-page booklet with 151 drawings, 33 photographs and four charts. It introduces and explains the use of dynamic signal analyzers that are designed for the analysis of signals in the relatively low frequencies produced by transducers. Such signals range from a few millihertz to 100 Hz. **Mfr: Hewlett-Packard Company, 1820 Embarcadero Rd., Palo Alto, CA 94303.**

MULTI-MODE™ BROCHURE

• A new engineering monograph, entitled "Theory and Operation of the Crown Multi-Mode™ Circuit," is now available from Crown. The monograph explains how the Multi-Mode circuit functions and the effect it has in keeping signal quality essentially unchanged from input to output. The Multi-Mode circuit design is currently employed in Crown power amps PS-200 and PS-400 for professional sound markets, and in the PL2 and PL3 amps for home audio. **Mfr: Crown International, Inc., 1718 W. Mishawaka Rd., Elkhart, IN 46517.**

ENGINEERING CATALOG

• A 64-page engineering catalog on Bucket Brigade Devices (BBD) is now available from the Electronic Components Division of Panasonic Industrial Company. The catalog presents detailed specifications on the company's complete line of BBDs, including 12 models and a clock generator driver. The catalog is designed to ease device selection. Beginning with a generalized description of BBDs, it then contains a brief selection guide based on the number of stages, followed by a table containing all the major specifications for each device. Once a user has determined roughly the right device for his application, he can turn to detailed specifications for the selected unit. These contain all the electric performance characteristics and parameters, applicable waveforms, characteristic curves, circuit diagrams, test circuits, as well as sample application circuits. **Mfr: Panasonic Industrial Co., One Panasonic Way, Secaucus, NJ 07094.**

Digital Recording Facilities Directory

The following information, courtesy of the Recording Industry Association of America (RIAA), is a list supplied by manufacturers on headquarters and U.S. and international locations available for commercial rental of digital recording/editing services....

JVC Cutting Center, Inc.

RCA Bldg., Suite 500
6363 Sunset Blvd.
Hollywood, Calif. 90028
(213) 467-1166

Larry Boden, Manager, Headquarters and Rental Facility.

American Multimedia
Route 8, Box 215-A
Burlington, N.C. 27215
(919) 229-5554, Richard Clark
Capitol Records Studios
1750 N. Vine St.
Hollywood, Calif. 90028
(213) 462-6252, Charles Comelli

Digital by Dickinson
9 Westinghouse Plaza
Bloomfield, N.J. 07003
(201) 429-8996, Frank Dickinson
Master Technologies
28 Music Square East
Nashville, Tenn. 37203
(615) 327-4533, Glenn Meadows

Canada:

Le Studio
201 Perry Rd.
Morin Heights, Quebec J0R 1H0
(514) 226-2419, Yael Brandeis

England:

Abbey Road Studios
3 Abbey Rd.
St. John's Wood, London NW8 9AY
(01) 286-1161, Ken Townsend

Japan:

JVC Adyama Studios
2-21-1 Jingu-mae
Shibuya-ku, Tokyo 150
(03) 403-0111, Kiyoshi Okumura
JVC Yokohama Cutting Center
3-12 Moriya-cho
Kangawa-ku, Yokohama
(045) 453-1111, Mr. Niimi
Camerata Tokyo
4-26-32 Jingu-mae
Shibuya-ku, Tokyo
(03) 405-6081, Hiroshi Isaka

Mexico:

Universidad Veracruzana
Teatro Del Estado
Nalapa, Veracruz
(281) 8-08-34, Jonathan Warren

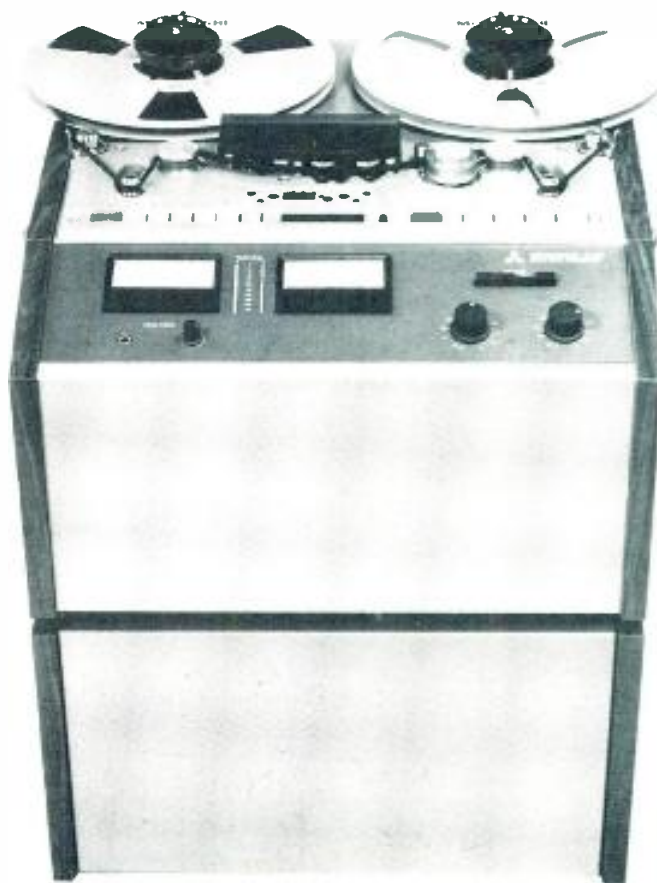

Mitsubishi Electric Sales America, Inc.

Digital Audio Division
110 New England Ave. West
Piscataway, N.J. 08854
(201) 981-1414 or (800) 323-4216
Lou Dollenger, National Sales Manager;
Sonny Kawakami
7045 N. Ridgewood Ave.
Lincolnwood, Ill. 60645
(312) 982-9282 or (800) 323-4216

Audioforce Inc.
38 W. 26th St.
New York, N.Y. 10010
(800) 847-4123, (212) 741-0919, Sid Zimet, Lucy Vargas

Fantasy Records Recording Studio
 10th at Parker
 Berkeley, Calif. 94710
 (415) 549-2500. George Horn. Andrea Salter. Roy Segal
 Road 80 Recording
 44 Farley Rd.
 Scarsdale, N.Y. 10583
 (914) 725-4135. Tom Jung

Japan:

Mitsubishi Electric Corp.
 2-2-3 Marunouchi
 Chiyoda-ku, Tokyo 100
 (03) 218-2111. Mr. Awazu. Denkanko Dept.



Sony Professional Digital Audio Division
 700 W. Artesia Blvd.
 Compton, Calif. 90220
 (213) 537-4300
 Rick Plushner, National Sales Manager.

Sony Drive

Park Ridge, N.J. 07656
 (201) 930-6000

Nick Morris, General Manager.

AAG Music
 200 Varick St.
 New York, N.Y. 10014
 (212) 924-3303. McDonald Moore

American Gramophone
 206 S. 44th St.
 Omaha, Neb. 68131
 (402) 553-1164. Don Sears

CBS Records
 49 E. 52nd St.
 New York, N.Y. 10022
 (212) 975-5901. Diane Brooks

Clover Recording Studios
 6232 Santa Monica Blvd.
 Hollywood, Calif. 90038
 (213) 463-2371. Dan Moorehouse

Digital Magnetics
 1800 N. Argyle Ave.
 No. 310, Hollywood, Calif. 90028
 (213) 463-0279. Jim Pace

Digital Services Recording
 1001 River Oaks Bank Tower
 2001 Kirby Dr.
 Houston, Tex. 77019
 (713) 520-0201. John Moran Jr.
 Digital Sound Recording
 607 North Ave. 64
 Los Angeles, Calif. 90042
 (213) 258-0048. Van Webster
 Frankford Wayne Mastering Labs
 1697 Broadway
 New York, N.Y. 10019
 (212) 582-5473. Tom Steele
 Master Digital
 202 Main St.
 Venice, Calif. 90291
 (213) 399-7764. Roger Pryor
 Middle Ear Studios
 1801 Bay Rd.
 Miami, Beach, Fla. 33139
 (305) 672-2390. Dale Peterson



Miller & Kreisel Sound Corp.
 10391 Jefferson Blvd.
 Culver City, Calif. 90230
 (213) 204-2854. Ken Kreisel
 Motown Hitsville USA
 7317 Romaine St.
 Hollywood, Calif. 90046
 (213) 850-1510. Guy Costa
 Spectrum Studios
 3015 Ocean Front Walk
 Venice, Calif. 90291
 (213) 399-9218. Arnie Frager
 Wakefield Manufacturing
 1745 W. Linden St.
 Phoenix, Ariz. 85007
 (602) 252-5644. Kent Smithiger

Japan:

CBS/Sony Inc.
 Digital Audio Division
 P.O. Box 17
 Tokyo International Airport, Tokyo 149
 (03) 266-5770

Soundstream

2505 Parleys Way
 Salt Lake City, Utah 84109
 (801) 486-4701
 Roger Russell, Director of Operations.
 Headquarters and Rental Facility.

Soundstream, Los Angeles
 5555 Melrose Ave., Studio G
 Los Angeles, Calif. 90038
 (213) 871-8028. George Korngold, Jim Wolvington

Soundstream, Boston
 76 Green St.
 Jamaica Plain, Mass. 02130
 (617) 522-5613, N.Y. Teline (212) 534-7477
 John Newton, Sydney Davis

England:

Soundstream, U.K.
 14 Drake Rd.
 Chessington, Surrey KT9 1LW
 (44) 1-391-0307. Brian Roberts

Federal Republic of Germany:

Soundstream
 GmbH, Carl-Bertelsmann-Strauss 161
 D-4830 Gutersloh 1
 (49) (5241) 76033. Martha DeFrancisco

**3M Digital Audio Systems**

3M Center
 St. Paul, Minn. 55144
 (612) 733-7358
 Clark Duffey, Market Development Manager.
 Maud Moon Weyerhaeuser Music Studio
 Minnesota Public Radio
 45 E. Eighth St.
 St. Paul, Minn. 55101
 (612) 221-1536. Tom Voegli
 Record Plant
 8456 W. 3rd St.
 Los Angeles, Calif. 90048
 (213) 653-0240. Chris Stone
 Digital By Dickinson
 9 Westinghouse Plaza
 Bloomfield, N.J. 07003
 (201) 429-8996. Frank Dickinson

Soundworks Recording Studios
 254 W. 54th St.
 New York, N.Y. 10019
 (212) 247-3690. Charles Benanty, Alan Ramer
 Universal Recording Corp.
 46 E. Walton St.
 Chicago, Ill. 60611
 (312) 642-6465. Murray Allen
 Warner Bros. Records
 11114 Cumpston Ave.
 North Hollywood, Calif. 91601
 (213) 980-5605. Lee Herschberg
 Westlake Audio
 7265 Santa Monica Blvd.
 Los Angeles, Calif. 90046
 (213) 851-9800. Glenn Phoenix

England:

Roundhouse Studios
 100 Chalk Farm Rd.
 London NW1 8LH
 (01) 485-0131. G. Bron, P. Gallen, Miss A. Massey

Federal Republic of Germany:

Bauer Tonstudio GmbH
 Markgroeninger Str. 46
 D-7140 Ludwigsburg 10
 (07) 141-31097. Rolf Bauer
 Dierks-Studios GmbH
 Haupt Str. 33
 D-5024 Pulheim Cologne 3
 (02) 238-3333, 20-04. Dieter Dierks
 Farian Music Productions
 Die Sang 9
 D-6331 Rossbach
 (06) 003-8081. Frank Farian
 Polygram Studios
 Kluesried 26
 D-3000 Hannover-Langenhagen
 (05) 11-73061

France:

Continental Studio
 84 Rue des Martyrs
 85018 Paris
 606.60.22. Dominic Blanc-Franchard
 Studio Grande Armee
 12 Av. de la Grande Armee
 75017 Paris
 (01) 764.13.47. Carla Guiot
 Studio Guillaume Tell Studio Marcadet Sarl
 25 Rue Duhesme
 75018 Paris
 259.92.40. George Blumenfeld

Japan:

Alfa & Assocs., Inc., Ltd.
 39-5-3 Shibaura
 Chuo-ku, Tokyo 108
 (03) 455-1791. Kumihiko Murai
 Onkio Haus
 1-23-8 Ginza
 Chuo-ku, Tokyo 104
 (03) 564-4181. Mitsuhiro Hirao

Sweden:

Polar Music Studios
 Polar Music AB
 St. Frikskatan 58-60
 S-11234 Stockholm
 (08) 54 06 95. Leif Mases

Closing date is the fifteenth of the second month preceding the date of issue.
Send copies to: Classified Ad Dept.
db THE SOUND ENGINEERING MAGAZINE
1120 Old Country Road, Plainview, New York 11803

Minimum order accepted: \$25.00
Rates: \$1.00 a word
Boxed Ads: \$40.00 per column inch
db Box Number: \$8.50 for wording "Dept. XX." etc.
Plus \$1.50 to cover postage

Frequency Discounts: 6 times, 15%; 12 times, 30%

ALL CLASSIFIED ADS MUST BE PREPAID.

FREE 32pg Catalog & 50 Audio Video Applic.



PHONO SUPP. EQ.
PHONO MIC
TRANS. ACM
TAP. VIDEO
LINE OSC

Stereo Mono Pwr Ampl
Video & Audio Dist Amps
8-in 2-out, 12-in 4-out, 18-in 4-out
TV Audio & Recd Prod Consoles

OPAMP LABS INC (213) 934-3566
1033 N Sycamore Av LOS ANGELES CA. 90038

THE LIBRARY Sound effects recorded in STEREO using Dolby throughout. Over 350 effects on ten discs. \$100.00. Write The Library. P.O. Box 18145, Denver, Colo. 80218.

ROCKET STUDIOS—All inventory, Teac 90-16, Pioneer 4-2 track, Allen-Heath modified 16 x 8 x 16, Neumann, Ecoplate, AKG. much more, complete studio \$50,000. (303) 567-2965, (303) 526-1881.

PROFESSIONAL AUDIO EQUIPMENT
Shop for pro audio from N Y's leader. no matter where you live! Use the Harvey Pro Hot Line (800) 223-2642 (except N.Y., Ak & Hi.) Expert advice, in-depth parts dept. 1/4" video systems available. Broadest selection such as Otari, Quad Eight, Soundcraft, Tascam and more. Write or call for price or product info.

Harvey Professional Products Division
25 W. 45th Street
New York, NY 10036
(212) 921-5920

FOR SALE

REELS AND BOXES 5" and 7" large and small hubs, heavy duty white boxes. W-M Sales, 1118 Dula Circle, Duncanville, Texas 75116 (214) 296-2773.

CUSTOM LENGTH CASSETTE BLANKS made to order featuring AGFA, Scotch, and Magnetic Media tape, any length from C-2 through C-122. For pricelist write M & K Recordings, Box 195d, Mt. Morris, MI 48458 or call (313) 687-7610.

USED RECORDING equipment for sale. Dan (415) 441-8934.

BLANK AUDIO AND VIDEO CASSETTES direct from manufacturer, below wholesale, any length cassettes: 4 different qualities to choose from. Bulk and reel mastertape—from 1/4-inch to 2-inch. Cassette duplication also available. Brochure. **Andol Audio Products, Inc., Dept. db, 42-12 14th Ave., Brooklyn, NY 11219. Toll free 1-800-221-6578, ext. 1, NY residents (212) 435-7322.**

AKG C-12A
Condenser mic w/ Nuvistor amp, audio-ophile's pet, absolutely Pristine! \$1,065. Call after 5 PM or weekends.
(213) 243-0441

THE MOST FLEXIBLE MICROPHONE & SNAKE CABLE
Available... 1 to 24 pairs. No jacket shrinkage while soldering. Call/Write for FREE CATALOG. **BI-TRONICS Inc., Dept. D, Box 125, Tuckahoe, NY 10707. (212) 585-1645.**

FOR SALE EVENTIDE H910 harmonizer. Brand new. \$1100. Mike Phillips, WLNC, (919) 276-1300.

MCI JH24B, JH100 16 track, locator, mint \$13,500.00. Electrodyne 16x8 console, \$3,500.00. Ampex AG 440, 7.5, 1/2 tk., \$1,800.00. (513) 258-2463.

SURPLUS JBL TWEETERS. NEW. Ideal for disco tweeter arrays or improving sound reinforcement and home loud-speaker systems. Specify choice of bullet or slot lens type. \$80 plus \$2 shipping each. Add sales tax if in NY. **Rosner Custom Sound, 11-38 31 Ave., L.I. City, NY 11106. (212) 726-5600.**

FOR SALE—AUDIO CONSOLE MIXER. Tapco-C-12 includes twelve inputs, equalization each channel, four submasters, much more. New condition. \$1900. **WQRC (617) 771-1224.**

FOR SALE AKG C-24 and other tube type condenser mics. (415) 441-8934 or 527-6167.

ACOUSTIC TEST INSTRUMENTS
USE TO ADJUST EQUALIZERS, OPTIMIZE SPEAKER PLACEMENT, ETC.



Complete Test Set	\$449
Calibrated Sound Level Meter	\$199
Fractional Octave Pink Noise Generator	\$339
Handbook on Acoustic Testing	\$10

Free broch. HALL ENGINEERING Dept. E5
P.O. Box 506 Martinsville NJ 08836
(201) 647-0377

ORBAN and LEXICON. All products in stock. FOR IMMEDIATE DELIVERY. **UAR Professional Systems, 8535 Fairhaven, San Antonio, TX 78229. 512-690-8888.**

FOR SALE: YAMAHA PM 1000-24 mixing console. 32 main frame. Carlo ATA case. gooseneck lights, excellent condition. Must sell—best offer **Mark Lowrance (901) 885-4504.**



WANT TO ELIMINATE FEEDBACK HOWL WITHOUT GAIN REDUCTION... ACTUALLY WITH INCREASED GAIN? FIND OUT ABOUT OUR FEEDBACK STABILIZERS MOD. 741XR & 742XR.

BODE SOUND CO.
1344 ABINGTON PL.
NO. TONAWANDA, N. Y. 14120
716-692-1670

— ANNOUNCING —

“LOUDSPEAKER ARRAYS — A GRAPHIC METHOD OF DESIGNING”

Now the design of loudspeaker arrays is as easy as the design of the rest of the sound system. Our method is easy to use, is fast and accurate!

We will design your array or do any of the steps you don't want to do in the array design process.

Either way, you end up with a description of the array, and drawings from as many views as you want.

Call
or write: **(612) 871-6446**

* **north star sound UMBULUS**
1406 First Avenue South
Minneapolis, MN 55403
Thomas McCarthy, Chief Engineer

MUST SELL: SOUND Technology 1500A
Tape Recorder/Analyser. 6 mos. old—
never used. Asking \$5,500.00. sells new
\$6,400.00. **Please call: (303) 750-6474 or**
(303) 733-3245.

PRO AUDIO IN STOCK ready to ship. Top
lines, top dollar trade-ins, clearance spe-
cials. Call or write for our prices. **Profes-**
sional Audio Video Corporation, 384 Grand
Street, Paterson, NJ 07505 (201) 523-3333.

FOR SALE TANGENT 3216 16 x 16 mixing
console. Otari MTH-90 16 trk recorder
w/autolocator. Low hours/mint condition.
(312) 525-6565.

WANTED

WANTED: TRANSCRIPTION discs, any
size, speed. Radio shows, music. **P.O. Box**
724—db, Redmond, WA 98052.

EMPLOYMENT

Audio Technician

Minimum of 2 years' expe-
rience in bench and field
work.

Audio Engineer

B.S. or equivalent. Expe-
rienced in system design,
construction and mainten-
ance.

Please send resume including salary history and require-
ments to the attention of Bob Hemenway.



P.O. Box 65
Newton, MA 02160
An Equal Opportunity Employer

SERVICES

VIF INTERNATIONAL will remanufacture
your Ampex or Scully (Ashland/Bodine)
direct drive capstan motor for \$200. Average
turn around time—2-3 weeks. For details
write **PO Box 1555, Mtn. View, CA 94042,**
or phone **(408) 739-9740.**

MAGNETIC HEAD relapping—24 hour
service. Replacement heads for profes-
sional recorders. **IEM, 350 N. Eric Drive,**
Palatine, IL 60067. (312) 358-4622.

ACOUSTIC CONSULTATION—Special-
izing in studios, control rooms, discos.
Qualified personnel, reasonable rates.
Acoustilog, Bruel & Kjaer, HP, Tektronix,
Ivie, equipment calibrated on premises.
Reverberation timer and RTA rentals.
Acoustilog, 19 Mercer Street, New York,
NY 10013 (212) 925-1365.

INSTRUCTION

Available from **SHERMAN KEENE PUBLI-**
CATIONS: a recording textbook, a rec.
theory correspondence course, and a
newly completed vastly expanded cur-
riculum for rec. school's incl. teacher's
manual, student workbook and finals. Our
book, "Practical Techniques for the Re-
cording Engineer" acclaimed by review-
ers, teachers and engineers. 381 pages,
28 chapters (4 on computer mixing). Cer-
tificate course features reading and home-
work in 2 textbooks and personal dialog
with the author via cassette. Textbook:
\$29.75 (\$31.54 in Calif.) plus \$2.75 ship-
ping. Course: \$250 per level (3 levels). To
order or for more info write to: **SKP, 1626**
N. Wilcox, No. 677-D, Hollywood, CA
90028.

UH-OH!



Have you mis-
placed your db
again? Our
high quality,
royal blue vinyl
binders keep
12 copies of
db neat and
handy for
ready
reference.

Just \$9.95,
available in
North America
only. (Payable
in U.S. currency
drawn on U.S.
banks.) **ORDER**
YOURS NOW!!

Sagamore Publishing Co., Inc.
1120 Old Country Road
Plainview, NY 11803

YES! Please send _____ db binders
@ \$9.95 each, plus applicable sales tax.
Total amount enclosed \$ _____

Name _____

Company _____

Address _____

City _____

State Zip _____

People..Places..

- Sony Corporation has recently announced that **Kazuo Iwama**, its president and chief operating officer, died on August 24, 1982. Iwama joined Sony (then Tokyo Telecommunications Engineering Corporation) in June, 1946. Together with Masaru Ibuka, the founder of Sony Corporation and the present honorary chairman, and Akio Morita, the present chairman, Iwama was responsible for the growth of Sony as an electronics leader.

In 1953, Iwama headed a special task force to study the development and production of transistors for use at radio frequencies. His efforts in this area led to the production of Japan's first transistor radio by Sony in 1955 and the introduction of the world's first transistorized television receiver in 1960. In May 1971, he was appointed president and chief executive officer of Sony Corporation of America. Iwama played a key role in working out plans by which Sony became the first Japanese electronics company to build a color TV manufacturing plant in the United States.

Upon returning to Tokyo in June 1973, Iwama was appointed deputy president. In January 1976, he was named president and chief operating officer. In April 1979, he received the medal of honor with blue ribbon from His Majesty, the Emperor of Japan.

- The president and chief executive officer of the **Panasonic Industrial Company**, Mr. **Ken Kurahashi**, has announced the formation of the Audio-Video Systems Division. The Audio-Video Systems Division incorporates the existing marketing lines of the Video Systems Division (Commercial Video VHS, Closed Circuit Television and Professional Video) and now includes Professional Audio Systems which markets the **Ramsa** product line of professional sound equipment. The Division also plans a Commercial Sound Systems line for the near future. Mr. **Toshio Iizuka**, formerly vice president and general manager, Video Systems Division, has been named vice president and general manager, Audio-Video Systems Division. The product management and marketing staff of the Audio-Video Division include: **Milton Landau**, group manager, Closed Circuit Television Commercial Sound Systems; **Mike Dollacker**, manager, Commercial Video VHS; **Dick Salam**, manager, Professional Audio Systems, and **Morris Washington**, manager, Professional Video. **Larry Ingenito**, National sales manager, is in charge of the sales group for all product categories.

- **Audiotechniques** has completed installation of a new MCI JH 636-36 automated recording console in RCA's famed Studio "A" in New York City. According to **Matt Brosious**, studio sales manager for Audiotechniques, the new 36 input console is supplied with dual microphone pre-amplifiers which allow for up to 72 active microphone inputs. Also installed with the console was a new MCI JH 24 multi-track recorder. Both console and tape recorder utilize differential technology for transformerless balanced inputs and outputs.

Following the installation, Audiotechniques' engineering director, **Richard Anderson**, conducted a day long technical and operational seminar on the MCI 600 console series for RCA engineering and production staffs. Recording engineer **Bruce Tergesen** from the **Hit Factory** in New York City presented a four hour program on the operational aspects of the new MCI console.

- **Roy L. Komack** has been appointed manager, business development for **Bose Corporation**. He will be responsible for product management in the home high fidelity, car stereo and professional sound equipment areas, and will supervise the company's customer service department. Komack will report to **John J. Geheran**, corporate vice-president of sales and marketing. Komack joined Bose in 1970 and was, previous to this appointment, marketing manager for professional products. He is credited with conceiving and launching the Bose professional products line, including the 802 and 402 loudspeaker systems. Previously, Komack served in the research and development and technical sales areas for **United-Carr, Inc.** of Newton, MA.

- **Ampex Corporation** has announced that the General Services Administration has awarded the company two contracts valued at \$10 million to provide recording tape in support of all facets of the government's magnetic tape requirements.

According to **Stanley W. Faught**, vice president and general manager of the Ampex Magnetic Tape Division, a \$7.4 million contract award is for precision instrumentation recording tape, which will be used in a variety of government-sponsored scientific research programs, including the space shuttle and other deep space missions. It marks the eleventh consecutive year Ampex has provided the GSA with instrumentation tape under the Federal Supply Schedule.

The other contract is a multiple, \$2.6 million award to supply the GSA with broadcast video, video cassettes, audio cassettes, open reel audio and mastering tapes, Faught said.

- **Jerome C. Smith** has been promoted to director of Marketing for **Cerwin-Vega**. The appointment was made by **Larry Phillips**, president of Cerwin-Vega International. Smith's new duties will include marketing and development of all Cerwin-Vega products such as "digital" loudspeakers, consumer electronics and loudspeaker systems, professional sound speaker systems, recording studio monitors, musical instrument sound reinforcement products and motion picture theatrical sound products in the USA. Smith will also oversee advertising and publicity functions.

- Effective September 1, 3M's Board of Directors named **Allan J. Huber** as executive vice president, Electronic and Information Technologies Sector. He had been executive vice president, Graphic Technologies Sector. In his new job, Huber succeeds **Erwin W. Brown**, who has elected to participate in a 3M early retirement program. In a related action, **Kenneth A. Schoen** was named executive vice president, Graphic Technologies Sector, to succeed Huber. Schoen had been group vice president, Tape, Adhesives and Decorative Products Group.

Huber joined 3M in 1953 as a sales representative for the Printing Products Division. He has held a number of U.S. and International management jobs, including managing director, 3M Germany; division vice president and group vice president. He was elected executive vice president, Graphic Technologies Sector, in March 1981.

- **Bogen Division of Lear Siegler, Inc.** today announced two new appointments as part of a reorganization of its Sales Department. **Robert K. Schindhelm** is National sales manager, Distributor Products. **Kenneth O'Brien** is Bogen's newest Sales Application engineer and reports to **Edward P. Draney**, National sales manager, Engineered Sound. Vice president, Marketing, **Joseph A. Palmieri** made the announcement. The reorganization includes complete separation of Bogen's two major customer and product categories: distributors, who purchase packaged sound products, and sound contractors, who order customized engineered systems and components. Robert Schindhelm comes to Bogen from **Audio Dynamics Corporation**. He earned several executive titles in both marketing and manufacturing during his nine years with the Connecticut firm. Schindhelm will be responsible for all phases of Bogen's distributor relations.

Kenneth O'Brien formerly was with **Electronic Specialty Services** in New Jersey. He will utilize his technical background in work with sound contractors on system design and quotations for Bogen's engineered sound products.

... & Happenings

BROADCAST HAPPENINGS

• The number of new members joining the **National Radio Broadcasters Association** set a new record in July when 70 members were added to the NRBA membership rolls. "This better our previous one month record set in October 1981, when 68 new members joined the Association," said **Jack Christian**, NRBA's VP for Membership Development. Christian reported that 60 station members and 10 associate members joined in July bringing the number of new members recruited by NRBA to 256 for the first half of 1982. This sets a pace well ahead of 1981 when a total of 395 new members were added to NRBA's membership list. In related broadcast news, **Edward O. Fritts**, president, **Fritts Broadcasting, Inc.**, Indianola, Miss., was elected **National Association of Broadcasters'** next president at a special meeting of the NAB Joint Board of Directors. Fritts succeeds **Vincent T. Wasilewski** who announced his intention to retire on the naming of a successor earlier this year. Fritts, who will be the Association's 19th president, was in his second term as chairman of NAB's Joint Board. He was elected to the Radio Board of Directors in 1977 and was its 1980-81 chairman and 1979-80 vice chairman. He is past chairman of NAB's Small Market Radio Committee, was a member of the Association's Radio Code Board and was an advisory trustee of the Television and Radio Political Action Committee. He also is past president of the Mississippi Broadcasters Association. Fritts started his career as a part-time announcer for **WENK**, Union City, Tenn. His broadcasting group includes **WFLA AM/FM**, Indianola, **WELO** and **WZLQ**, Tupelo, all in Mississippi; **KMAR AM/FM**, Winnsboro, La., and **KCRI**, West Helena, and **KCRI-FM**, Helena, Ark. He is affiliated with his father, **Edward B. Fritts**, in ownership of **WPAD** and **WDDJ**, Paducah, Ky.

EVERYONE WANTS TO GET INTO THE ACT!

• The U.S. Supreme Court announced that it will review the Ninth Circuit Court of Appeals' decision in **Universal Studios v. Sony Corporation of America**, the essence of which was that video taping, even for private, non commercial use, constitutes copyright infringement. Immediately following the Supreme Court's grant of certiorari, the record industry declared that, since the Sony case deals only with the question of *video* taping, its lobbyists would continue to press for enactment of a tax on the sale of *audio* hardware and tape.

Reaction to this move by the record industry has been both swift and predictable. Commenting on the tax legislation pending before Congress, Sony Corporation of America president **Kenji Tamiya** said, "We are firmly opposed to any bill that would impose a royalty tax on home recording devices and blank tapes."

The spokesman for the newly-established **Audio Recording Rights Coalition (ARRC)**, **Jack Wayman**, flatly rejected the record industry's contention that declining record sales are the result of audio taping. Wayman, senior vice president of the **Electronic Industries Association**, which counts among its members the principal audio equipment and blank tape manufacturers, explained that "the main reasons for the decline in record sales are the current recession, the competing video revolution, and the marked decrease in the number of 14 to 24 year-olds. The record industry's royalty tax scheme," continued Wayman, "is inequitable and unjustifiable."

Tetifying before the House Judiciary Subcommittee on Courts, Civil Liberties and the Administration of Justice, Wayman questioned the reliability of an audio taping study commissioned by Warner Communications Inc. and challenged that company to release its questionnaire and full results.

However, even the Warner study shows that 34 percent of the time spent

taping is for non-music and non-infringing uses, and that 75 percent of those who *do* tape do so for reasons other than to avoid buying a record or prerecorded tape.

"Even if the Committee believes that those who tape records are significantly injuring the record industry," said Wayman, "we [the EIA and ARRC] believe legislation would not only fail to remedy the problem, but would impose substantial costs on consumers and the free marketplace."

Stay tuned for what appears to be a long (and costly) battle.

THIEVES WITH GOOD TASTE

• 40 SL611E Total Recall Input Output modules were stolen from the **Solid State Logic** console at **Tennessee Tonstudios** in Hamburg, West Germany over the weekend of July 16th. Thieves broke through the main entrance doors of the facility and removed all of the modules from the new SSL, which had been installed 4 months ago. They left only the console mainframe and master electronics section. The serial numbers of the modules, valued at over 67,000 Pounds Sterling, are SL 611E 1479-1519. Before leaving the premises, the intruder(s) cut all of the studios cabling runs. This casts the episode as an act of industrial sabotage rather than an ordinary theft. A spokesman for SSL confirms that it would be highly unlikely that the modules could be resold, and even more unlikely that an individual could use them to construct their own console.

Peter Struven of Tennessee Tonstudios states "Our studio has been highly successful in a competitive marketplace, but I do not know why anyone would go to such extremes to damage our business." Struven had just completed his re-building program, following a major fire in June of 1981, which coated all of the former equipment with PVC residue. The cause of that fire remains officially unknown, but arson is suspected. Anyone who may have information on the whereabouts of the stolen SSL modules is urged to contact Peter Struven at Hamburg 652 2981, or to contact Solid State Logic UK (099) 389 8282 or US (202) 333-1500.

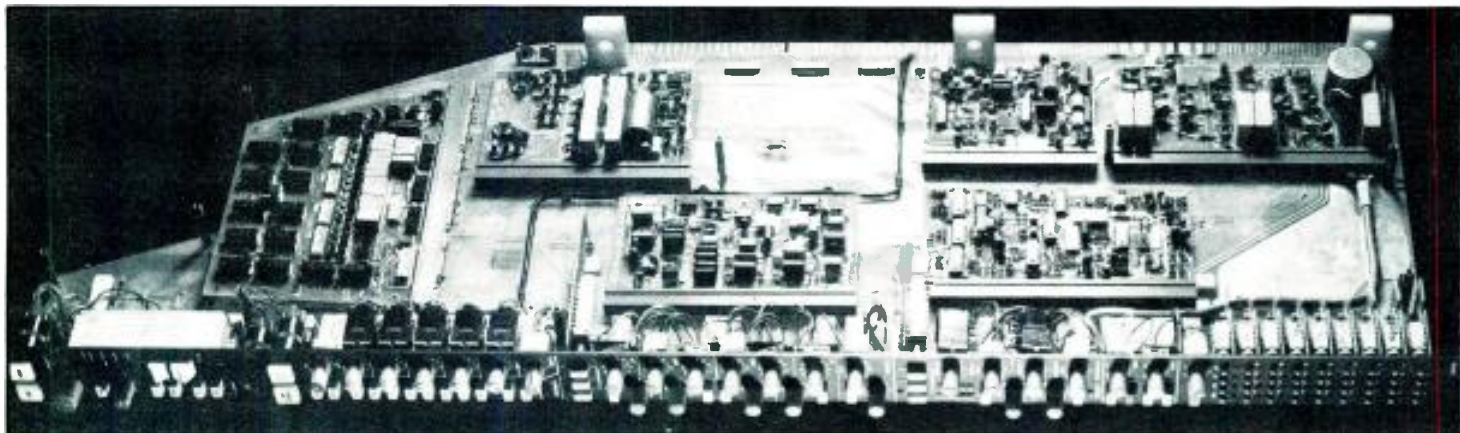

Have you seen this module?

**It takes you
where no reverb has ever
gone before!**



**The "X"
...the ultimate
reverb.**

Ultimate Sound Quality

Hear it to believe it! Enhanced clarity and openness with full audio bandwidth for sound quality second to none — a new world standard.

Split Reverberation

A Lexicon first! The "X" incredibly can operate as two separate stereo output reverbs with each channel independently adjustable.

Ultimate Repertoire

33 factory programmed pre-sets from 13 basic program families are provided. Punch up any of 10 Plates, 8 Halls, 6 Rooms/Chambers, 3 Hall/Plate combinations plus 6 effects such as arpeggiated chordal resonance and

multiband chorus and delays. Or, recall any of 36 of your own pre-sets from non-volatile user registers.

Creative Versatility

New Dynamic Decay feature allows separately controlled reverb times during pauses in program material and 6 individually adjustable pre-echos give new dimensions of expression.

Ongoing Factory Support

New programs/software updates are included free for 5 years after purchase excepting a small handling charge.

Call or write for a demo of the ultimate reverb in your space.

lexicon

60 Turner Street, Waltham, Massachusetts, U.S.A. 02154 • 617-891-6790 TELEX 923468

Export: Gotham Export Corporation, New York, NY 10014

Circle 24 on Reader Service Card

The new UREI Series "A" Time-Aligned™ monitor systems and their equals, the UREI Listening Amplifiers.

For the purest sounds you've ever heard, audition the critically engineered and listener proven UREI professional monitoring systems.

Now available

with your choice of three accurate Time-Aligned™ monitors and four sonically superb power amplifiers.

From small intimate listening situations to the most spacious environments... from studio control rooms to massive sound reinforcement, the solution to critical music reproduction for the audio professional is awaiting your evaluation at your authorized UREI dealer.

Evaluate the combined technology of a total UREI monitoring system and you will know and appreciate why your peers have made UREI the *new monitoring standard*.

®Time-Align is a Trademark of E.M. Long Assoc., Oakland, CA.
All referenced Trademarks are property of, or licensed by,
United Recording Electronics Industries, a URC Company.

UREI From One Pro To Another

United Recording Electronics Industries, a URC Company

8460 San Fernando Road, Sun Valley, California 91352

(213) 767-1000 Telex: 65-1389 UREI SNVY

Worldwide: Gotham Export Corporation, New York

Canada: E. S. Gould Marketing, Montreal

See your professional audio products dealer for full technical information.

UREI: The NEW Monitoring Standard

