



THE ELECTRONIC COTTAGE

Guides: Tape Recorders and Tape  
and Booms, Stands, and Cases



INTRODUCING THE NEW MX-55



## THE NEXT "WORKHORSE."

Before you take us to task for trying to improve the BII, a design that has become the "workhorse" standard for two-channel audio machines, consider what the new MX-55 offers:

An integral autolocator; a voice editing mode that allows 2X speed playback at normal pitch; a built-in cue speaker, GSPiPO (gapless, seamless, punch in, punch-out),\* and because you told us you wanted it, *all* adjustments are available through the front panel! These, and many more improvements will help make your job easier, and the results more creative.

And for those of you who still won't forgive us, we're keeping the BII in the line. So either way, you can get exactly what you need from Otari; Technology You Can Trust. Call Otari at (415) 592-8311 for information about the new MX-55. **OTARI**



# THE ELECTRONIC COTTAGE

<b>STRATEGIC PLANNING FOR THE SMALL STUDIO</b>	<b>7</b>
<i>Rick Shriver.</i> The co-owner of Atmosound once wrote an article on studio construction. Now he's back explaining the organizational and planning techniques he and his partners used.	
<b>PARAMOUNT'S ELECTRONIC COTTAGE</b>	<b>13</b>
<i>Corey Davidson. COVER STORY.</i> Corey interviews Frank Serafine who talks about his own studio and how he replicated that at Paramount.	
<b>LIFE IN THE ELECTRONIC COTTAGE</b>	<b>31</b>
<i>John Barilla.</i> An introduction to the concept behind The Electronic Cottage.	
<b>LAB REPORT—YAMAHA MT 2X MULTI-TRACK RECORDER</b>	<b>49</b>
<i>Len Feldman</i>	
<b>HANDS ON—FOSTEX 460 RECORDER/MIXER</b>	<b>69</b>
<i>Bruce Bartlett</i>	

## The recording engineer

<b>RECORDING LIZA MINNELLI — THE CHALLENGE</b>	<b>56</b>
<i>Jack Renner.</i> The chairman and CEO of Telarc International describes the setup used to record Liza at Carnegie Hall.	
<b>FROG TO PRINCE: RCA TO BMG</b>	<b>63</b>
<i>Corey Davidson.</i> Corey talks to Don Frey at BMG (formerly RCA) about the history of the studio and how things are now changing.	

## The broadcast engineer

<b>LA BROADCASTING</b>	<b>22</b>
<i>Ralph Mitchell.</i> As KSLA-TV expanded with new equipment, their audio booth needed remodeling.	

## The sound contracting engineer

<b>SOUND REINFORCEMENT IN SOUTH AND CENTRAL AMERICA — PART II</b>	<b>32</b>
<i>Ed Learned.</i> Ed continues touring with Wayne Toups and his band, and finds a few more problems.	
<b>SPEAKER COVERAGE UNCOVERED</b>	<b>59</b>
<i>Bob Thurmond.</i> Bob returns to db Magazine with a technique he developed to improve speaker coverage.	

### About the Cover

● Frank Serafine, whose new involvement with Paramount Pictures is detailed on page 13, is seen in his own studio complex. Soon, he tells us, it will be replaced by an all new complex, but that's a story for a future issue.

<b>EDITORIAL</b>	<b>2</b>
<b>LETTERS</b>	<b>4</b>
<b>CALENDAR</b>	<b>6</b>
<b>BROADCAST AUDIO—Randy Hoffner</b>	<b>20</b>
<b>BUYERS GUIDE: Tape, Tape Recorders, Cases, Racks, Stands, Booms</b>	<b>33</b>
<b>HOT LINE</b>	<b>48</b>
<b>AD VENTURES—Brian Battles</b>	<b>73</b>
<b>NEW PRODUCTS</b>	<b>77</b>
<b>CLASSIFIED</b>	<b>80</b>
<b>PEOPLE, PLACES, HAPPENINGS</b>	<b>81</b>

# Editorial



THE SOUND ENGINEERING MAGAZINE

Editor/Publisher  
**Larry Zide**

Associate Publisher  
**Elaine Zide**

Associate Editor  
**Carol A. Lamb**

Technical Editor  
**Corey Davidson**

Contributing Editors  
**Bruce Bartlett**  
**Mark E. Battersby**  
**Brian Battles**  
**Drew Daniels**  
**Len Feldman**  
**Randy Hoffner**

Graphics & Layout  
**Karen Cohn**

We said in an earlier editorial that there would be further changes in db Magazine's look and feel. Well, look at it, feel it, and tell us what you think.

But lest you think that this issue is finally *it*, there are still more changes, smaller, to be sure, to come.

The whole purpose of these changes is simply to make db Magazine easier to read, more enjoyable to the eye, as it is to the mind. Again, we hope our goals agree with your opinions, and we want you to tell us what you think.

On another matter, also mentioned before, the recent NAB Convention had a lot of things going. High definition television will be covered by other publications, but another feature of the show was the showing of R-DAT equipment—equipment that will be shipping even as you read this. Several manufacturers showed professional R-DAT equipment; Sony, Tascam, Panasonic, Fostex, come to mind. Sony is not yet shipping. I expect that we'll see some new designs by AES Convention time.

Panasonic showed several models, all professionally equipped with a balanced in and out but otherwise not much more than has been brought back from the Orient recently. They do have a true battery portable, though. And, they insist, shipments will be made by July (1988!). Distribution will be through the Ramsa group. Which makes sense, Ramsa is the professional arm of Panasonic (Matsushita).

What really garnered a great deal of interest at NAB was Fostex. They seem to have found a working way to put SMPTE time code onto an R-DAT machine, and that had competitive manufacturers interested, as well as the rest of us. Good for Fostex.

R-DAT is a fast-moving technology. It would seem that what is now coming available to the audio professional is just the beginning of a technology surge. From ENG to small-studio systems, there is digital recording, affordable digital recording, here already and coming soon, even more versatile.

You all know, of course, that the way was cleared for R-DAT to be imported. The copy-code spoiler system was shot down. There is no legal impediment for consumer or professional systems to come into the U.S. The record industry, who has opposed R-DAT (or S-DAT) has now taken the position that it will sue any manufacturer that imports consumer machines. The conservative Japanese companies are not confrontational. While there seems to be little merit to any such lawsuit, they do not want to be the ice-breakers. However, professional units are seemingly not affected. So, if an R-DAT has phone jacks it's not coming in. XLRs, o.k. Tell me the logic of that one! L.Z.

db, The Sound Engineering Magazine (ISSN 0011-7145) is published bi-monthly by Sagamore Publishing Company Inc. Entire contents copyright 1988 by Sagamore Publishing Company Inc., 203 Commack Road, Suite 1010, Commack, NY 11725. Telephone: (516)586-6530. db Magazine is published for individuals and firms in professional audio recording, broadcast audio-visual, sound reinforcement-contracting, consultants, video recording, film sound, etc. Application for subscription should be made on the subscription form in the rear of each issue. Subscriptions are \$15.00 per year (\$28.00 per year outside U.S. Possessions, \$16.00 per year in Canada) and payable in U.S. funds. Single copies are \$2.95 each. Editorial, Publishing, and Sales offices are at 203 Commack Road, Suite 1010, Commack NY 11725. Second Class postage paid at Commack, NY 11725 and an additional mailing office. **Postmaster: Form 3579 should be sent to db Magazine, 203 Commack Road, Suite 1010, Commack, NY 11725.** Trademarked names are editorially used throughout this issue. Rather than place a trademark symbol next to each occurrence, we state that these names are used only in an editorial fashion and to the benefit of the trademark owner, and that there is no intention of trademark infringement.



Imagine,  
**TELEX**  
**QUALITY**  
At Offshore  
Prices

## The Best of Both Worlds

It's now available with the new FMR-25 Wireless Microphone Systems made in the USA. For a list of important features that exceed

the competition and a price that doesn't, call or write Telex Communication, Inc., 9600 Aldrich Av. So. Minneapolis, MN 55420

**TELEX**<sup>®</sup>

Call Toll Free 1-800-328-3771  
Circle 13 on Reader Service Card

# Letters

Dear Editor,

I am a new subscriber and I have read my first two issues of db cover to cover. I am writing to complain about your publication. I have found ONE (1) thing that I do not like about it...I receive it in the mail, spend about the next two days devouring it, and then I have to wait six to eight weeks for the next issue to arrive. Isn't it criminal for you guys to inflict such anguish on your readers? Maybe we could have you flogged or something. The only re-

course I have is to go back to the previous issue and re-read it again.

Thank you for a great magazine, I really enjoy reading db!

A satisfied subscriber,  
Rodger McIntyre

Dear Editor,

It has now been more than a year since I sent for "new products" information. I have had no reply. I know that

I sent it within the time frame specified—four months—so it has me wondering on the effectiveness of the advertising you carry. The product in question was featured in the January/February 1987 issue of your magazine. I would appreciate it very much if you would send me the address of the manufacturer.

Marjorie Fossum  
Media Services

Dear Ms. Fossum,

*Please let me apologize for the delinquency of some of our new product listees. Every one of our advertisers has told us that they are very pleased to send out literature upon request. However, I cannot make that same guarantee about companies that are listed under New Products. Of course, if they ignore these requests, they are losing valuable sales leads. We can't make them do what they won't do.*

*Ed.*

Dear Editor,

I would very much like to receive db Magazine. Many times friends and colleagues have referred me to articles in db that I've been unable to find. I think it would be an excellent resource for my work here at Narada. Thank you for entering my subscription.

Best regards,  
John Chase  
Narada Productions

*It's always a pleasure to comply with so nice a request.*

*Ed.*

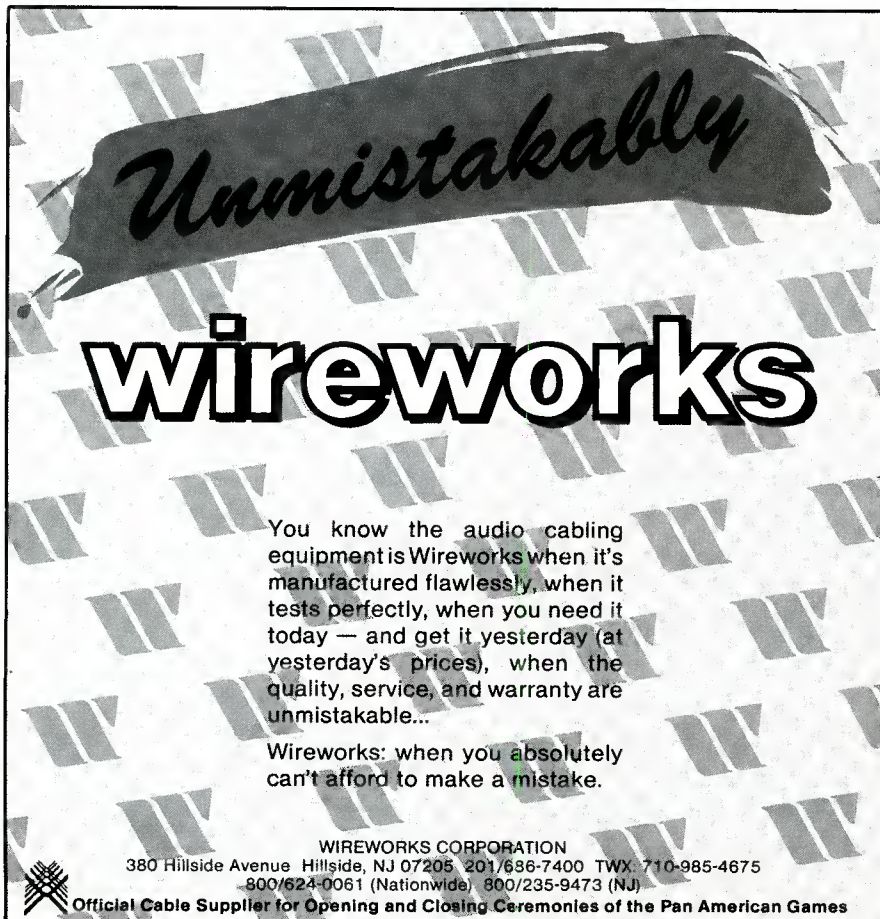

**Unmistakably**  
**wireworks**

You know the audio cabling equipment is Wireworks when it's manufactured flawlessly, when it tests perfectly, when you need it today — and get it yesterday (at yesterday's prices), when the quality, service, and warranty are unmistakable...

Wireworks: when you absolutely can't afford to make a mistake.

WIREWORKS CORPORATION  
380 Hillside Avenue Hillside, NJ 07205 201/636-7400 TWX: 710-985-4675  
800/624-0061 (Nationwide) 800/235-9473 (NJ)

Official Cable Supplier for Opening and Closing Ceremonies of the Pan American Games



# Of its 90 digital effects, these three are the most amazing: \$525.

You can count the price in hundreds on one hand. Yet you'd need the hands of eight more people to add up all the effects you get with the Yamaha REX50 Digital Multi-Effects Processor.

At about \$5.85 per effect, amazing is quite an understatement. Add to that not only the number, but the quality of the effects. Then remember you can have them all in your own home studio. In one compact, sleek unit.

First we borrowed 20 preset effects from the SPX90. Like reverb, early reflections, delay/echo, pitch change and modulation effect.

Then we added the world's first digital distortion. Ten of the hottest distortion effects preset in the REX50. That you can use alone, one right after another, or in combination with another effect.

Any of those preset 30 effects can be

changed, modified, customized, perfected and stored in 60 user-programmable slots that you can call your own on an LCD display.

And recall instantly via MIDI, remote or footswitch.

Yamaha's REX50 Digital Multi-Effects Processor. Just think what you could do once you get your ten digits on it. There's one waiting for a nice home at your Yamaha Professional Audio Dealer. See him today.

Yamaha Music Corporation, Professional Audio Division, P.O. Box 6600, Buena Park, CA 90622. In Canada, Yamaha Canada Music Ltd., 135 Milner Avenue, Scarborough, Ontario M1S 3R1.



**YAMAHA**  
Engineering Imagination™

## DID YOU KNOW?

You, our readers, are very important to us. Should you ever need to contact us about your subscription, please do not hesitate to write to us at:

db Magazine

Attn: Circulation

203 Commack Rd. Suite 1010

Commack NY 11725.

## HOW TO READ THE LABEL

The top line of your label contains information that enables us to find you on the computer. Without that we can't effect address changes or find your entry. The sample below is what most labels look like.

A11803SAG11 0787 9309

Sagamore Publishing Co

1120 Old Country Rd

Plainview, NY 11803

The first sequence of characters is how we locate you. The next four numbers indicate the issue you have just received. Finally, the last four numbers represent the date of expiry *reversed*. Just read backwards: 9309 is Sept/Oct 1993.



## REMOVES VOCALS FROM RECORDS!

Our VOCAL ELIMINATOR can remove most or virtually all of a lead vocal from a standard stereo record and leave most of the background untouched! Record with your voice or perform live with the backgrounds. Used in Professional Performance yet connects easily to a home component stereo system. Not an equalizer! We can prove it works over the phone. Write or call for a free brochure and demo record.

Listen...

## Before You Buy!

- Time Delay
- Reverberation
- Crossovers
- Noise Reduction
- Compressor/Limiters
- Expanders
- Spectrum Analyzers
- Parametric EQ

Don't have regrets about paying too much for a lesser product. In demos and comparisons, we'll show you why we're Better! Our Factory Direct sales allow us to produce a Superior product and offer it to you at a Lower price. Call or write for a free full length Demo Album and 24 page brochure.

**LT Sound**, Dept. DB-7, 7980 LT Parkway  
Lithonia, GA 30058 (404) 482-4724

**24 HOUR PHONE DEMO LINE: (404) 482-2485**

# Calendar

• A four-week program, comprised of six accredited graduate level courses in acoustics and signal processing, will be offered in June 1988 by Penn State's Graduate Program in Acoustics in cooperation with the University's Applied Research Laboratory. Courses offered include: **Fundamentals of Acoustics, Underwater Sound Propagation, Sonar Engineering, Digital Signal Processing, Electroacoustic Transducers, and Acoustical Data Measurement and Analysis.**

On October 10-14, 1988, a short course on Underwater Acoustics and Signal Processing will be offered at Penn State University. Among the topics to be presented are: An Introduction to Acoustic and Sonar Concepts, Transducers and Arrays, Signal Processing, Active Echo Location, and Turbulent and Cavitation Noise.

For more information contact:

**Dr. Alan D. Stuart**

Penn State Graduate Program in Acoustics

PO Box 30

State College, PA 16804

• The upcoming schedule for the **SYNERGETIC AUDIO CONCEPTS** two-day audio engineering seminars is as follows:

Toronto area- June 23-24

Syracuse- June 28-29

For more information contact:

**Synergetic Audio Concepts**

PO Box 1239

Bedford, IN 47421

• The Electronic Music Workshop will be held June 20-24, 1988, at New England Conservatory in Boston, Massachusetts. It will consist of lecture demonstrations followed by hands-on experience with a wide variety of both analog and digital synthesizers. No prior knowledge of electronic music is assumed or required. The workshop is available for undergraduate/graduate credit or non-credit. **Robert Ceely**, who is offering this workshop, is director of

the Electronic Music Studio at New England Conservatory. Contact **The New England Conservatory (290 Huntington Ave, Boston, MA 02115)** for further information.

• The Professional Education and Training Committee of the International Communications Associations (ICIA) is offering regional training seminars for the audio-visual and computer industries. The seminars will provide current information on the newest applications and techniques available on computer interfacing for projection and monitor displays. The dates are:

**New York: August 11-13**

**Toronto: September 1-3**

**Atlanta: October 6-8**

For more information, contact **ISIA (3150 Spring St., Fairfax, VA 22031-2399).**

• The 130th SMPTE Technical Conference and Equipment Exhibit will be held **October 15-19, 1988**, at the Jacob K. Javits Convention Center in New York City. The event annually provides a forum for discussions and demonstrations on advanced motion-picture and television technology. The theme of this conference is "Innovations in Imaging and Sound."

• The University of Iowa will hold the ninth annual Seminar in Audio Recording June 13-24, 1988, with **Jerry Bruck, Robert Ludwig and Lowell Cross** as principal instructors. Topics to be covered, and equipment to be demonstrated will include stereophonic and ambisonic microphone techniques, microphone comparisons, digital-analog and digital-digital comparisons, noise reduction systems, and the preparation of clients' tapes for CD and stereo LP mastering.

For more information contact:

**Prof. Lowell Cross**

**Recording Studios, School of Music**

**The University of Iowa**

**Iowa City, IA 52242.**



# “\$2500 Says You Can't Find a Better Gate!”

*Marvin Caesar, President*

**A**t Aphex we have a problem with the President. Marvin Caesar wants everything the company makes to be the “best.” Marvin is *not* an engineer, he is an audio zealot who doesn't understand the word “impossible.”

When engineering approached him with a design for a gate, he wasn't satisfied. He wanted the ultimate gate, an *expander/gate* that was extremely fast, perfectly click-free, loaded with features, with traditional Aphex audio quality.

Impossible with available technology they said. Marvin wasn't satisfied.

So, the engineers developed a new VCA, the Aphex VCA 1001. Then they created the Aphex 612 Expander/Gate. Marvin was finally satisfied.

In fact, he is so confident that the Aphex 612 is the world's best expander/gate he is offering \$2500 to the person who finds a better one. If you think you

know of a commercially available expander/gate that can begin to compete with the Aphex 612, write for full details of this offer.

If you would rather spend your time more usefully, contact your professional audio dealer for a demo of the best!

Here are a few highlights of the world's best expander/gate:

- Attack time—variable from less than 2 $\mu$ Sec (with no clicks!) to 100mSec
- Ratio—variable from 1:1 to 20:1
- Range—0 to 100dB
- Bandwidth—5Hz to 100kHz, + 0, - 0.2dB
- THD @ + 20dBm—0.006%
- IMD (SMPTE) @ + 10dBm—0.006%
- Noise and hum—fully attenuated - 94dBm
- Servo-Balanced Transformerless Inputs and Outputs

Can you beat that?

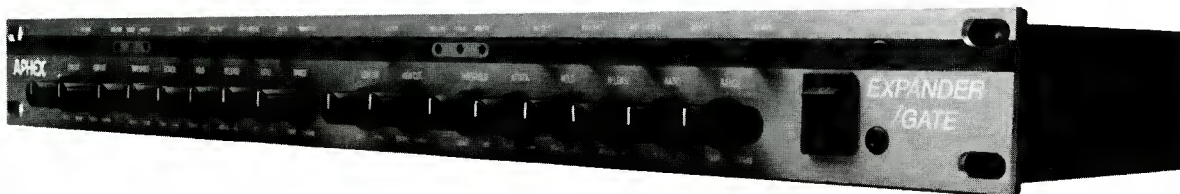

## **APHEX SYSTEMS LTD.**

Aphex Systems Ltd. • 13340 Saticoy Street • North Hollywood, CA 91605  
(818) 765-2212 • TWX: 910-321-5762



# Strategic Planning for the Small Studio

**T**he creation of a strategic plan, business plan, or long-range plan is often perceived as something reserved for the "big" studio or business. It is true that the larger businesses are most likely to engage in such planning processes. While our business is small by any definition, we developed a strategic plan

and discovered that it was an extremely valuable exercise.

---

**Of course, it is best for each organization to develop its own set of definitions...**

---

alize some of our goals and re-define others. In fact, the process of developing the plan was as valuable as the resulting document itself.

What we have done is provide an explanation of the strategic planning process so that other small studio owners may utilize this technique. The plan that is developed is useful not just to the operation and organization of the studio, but is tremendously valuable when seeking bank financing for some piece of equipment. It shows the lender that the business is well-organized, has a direction and can show how the equipment sought will help to achieve the business objectives. It will even help to de-mystify the recording or sound profession just a bit.

*Rick Shriver wrote "Atmosound: A Construction Story," in our September/October 1987 issue. He is co-owner of Atmosound, McConnellsville, Ohio, with Jeff Mercer and David King.*

## A PROCESS OF ORGANIZATION

Through the development of the plan we learned what our "unique competencies" were, what goals we want to be moving toward in the future, and as a result, we were able to focus our energies in a much more organized fashion. Thus, we have been able to re-



200 watt 6 Ch System  
with two 12" 820H  
enclosures & cables  
**DIRECT \$899**  
MX 621 (pw mixer only) - \$499



800 watt 8 Ch Stereo  
System with two 15" 960H  
enclosures & cables  
**DIRECT \$1699**  
MX 822S (pw mixer only) - \$1449

## HIGH PERFORMANCE SYSTEMS

---

**D**edication to quality and value are the bottom line with Carvin sound systems. With Carvin, quality is not a matter of chance. It is a deliberate engineering and manufacturing effort. MOSFET power is just one innovation delivering cleaner power and more of it... 800 watts on powered mixers and up to 2000 watts from a single FET 2000 amp supporting larger systems! All our systems are "component matched" offering extended dynamic range and greater output levels without distortion. We guarantee your satisfaction backed by our commitment to quality, performance and value.

In order for the strategic plan to become a usable document for the person not familiar with our profession, it is best to begin with the development of some operational definitions. For our planning, this meant defining "sound reinforcement," "public address," and "recording services" especially as they applied to our operations. With these definitions as a preface, the rest of the plan is readable and understandable, even for a banker.

Of course, it is best for each organization to develop its own set of definitions, but for us the distinctions were made:

"Sound reinforcement: systems typically composed of many input sources (mics, tape, etc.) with few output locations. (i.e. stage shows, musical acts, etc.)"

"Public address: systems which typically have few inputs (e.g. a single mic) but many output locations. (i.e. a paging system.)"

Finally we included a brief orientation to studio and remote recording as it applied to our situation.

With some understanding of the language of the business as a starting point, the second step is to outline the

planning process which will be utilized throughout the process. We have adopted a model of strategic planning (Figure 1).

The suggestion in this visualization is that environment (comprised of competition, economy, geographic markets, clients and technology) and the organization (affected by the mission statement, personnel, technical resources and financial resources) must both be considered in formulating the long and short-range objectives of the organization. From these objectives, the strategies are devised for the accomplishment of the organizational goals.

**Ultimately, a niche in the marketplace must be identified.**

#### STATEMENT OF MISSION

Step three in the preparation of the plan should be the articulation (or development) of the mission statement. Ideally this should begin with a

single sentence which states very simply what the business is about:

"It is the mission of *our studio* to provide professional audio services and consulting to the tri-state region at the lowest possible rates."

This basis for the mission statement should next be amplified through a series of supporting statements which develop more fully what the business is really about, what sets it apart from the rest and what special competencies allow that. This might include background and training of the personnel, the quality of equipment, the nature of the studio environment, or emphasis on turn-key packages in sound reinforcement.

With the above as prefatory material, step four of the plan should include more detailed information about the organization. Some historical background, current status and structure, projects under way and an autobiographical sketch of the personnel are all important components. Again, the focus of this section is the reinforcing of those aspects of the business that make it different from other similar businesses. Ultimately, a niche in the marketplace must be identified. In the



900 watt 16 Ch Stereo System with 3-Way 1330H speakers & cables  
**DIRECT \$3289**  
MX1622 (mixer only) — \$1489



1300 watt 24 Ch Tri-Amplified System with Horn Loaded EV Woofers and Drivers  
**DIRECT \$5359**  
MX2422 (mixer only) — \$2099

Write or call for a comprehensive catalog showing how to customize your own "state-of-the-art" sound system **FACTORY DIRECT.**

# CARVIN

... the professional's answer for quality since 1946.

**CARVIN** 1155 Industrial Ave., Escondido, CA 92025

Free Catalog  \$1 1st Class Mail

NAME \_\_\_\_\_

ADDRESS \_\_\_\_\_

CITY \_\_\_\_\_ ST \_\_\_\_\_ ZIP \_\_\_\_\_

DB87

**TOLL-FREE: (800) 854-2235**

**FACTORY DIRECT SALES:**  
1155 Industrial Ave., Dept. DB87  
Escondido, CA 92025

**HOLLYWOOD STORE:**  
7414 Sunset Blvd.  
Hollywood, CA

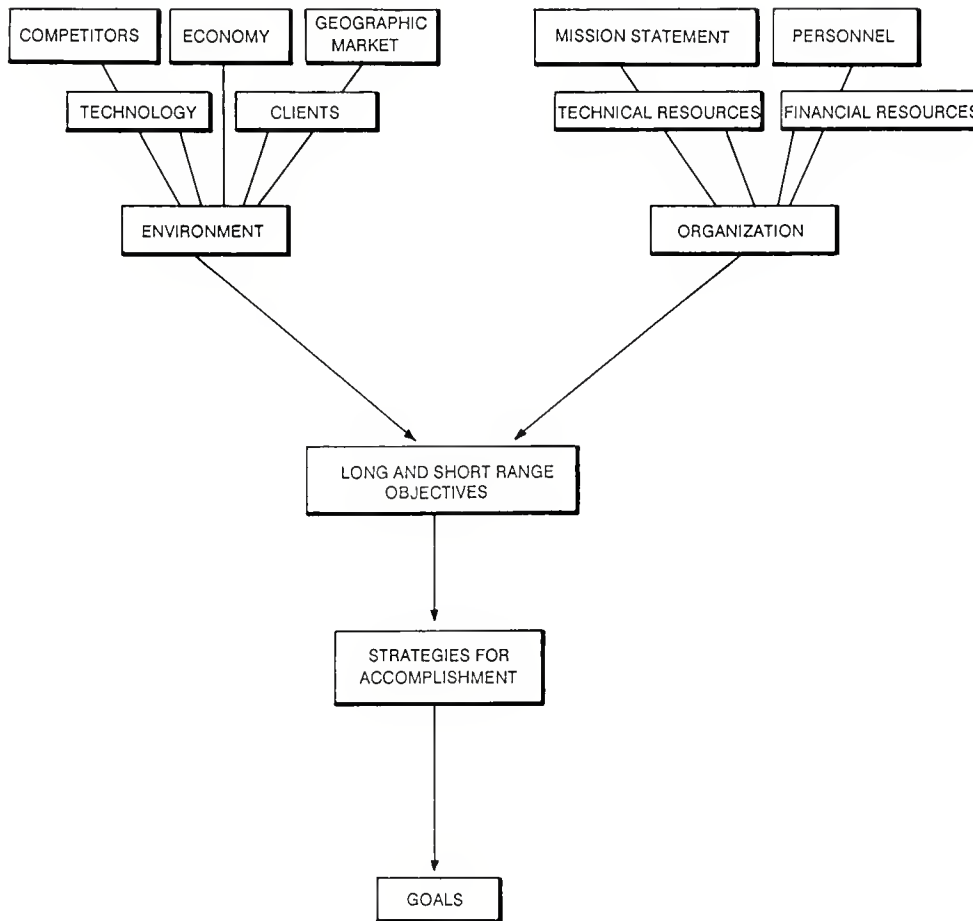

Figure 1. A flow chart of strategic planning.

section on personnel it is wise to include current resumes, along with a paragraph addressing the unique capabilities these people bring to the organization.

### MARKET DEFINITION

The fifth task, and last before articulating the “plan” itself, is to define the market. This must include a geographical analysis of the area from which clients will be drawn, as well as an analysis of who those clients are. Any examination of the market must also include the competition. That should be an honest appraisal of their strengths and weaknesses. In our profession, one must also recognize industry trends such as new technologies, economic climate and increasing specialization. Trade periodicals are obviously an invaluable source for this information and should be consulted regularly and cited in the planning document.

If all of the above has been honestly and thoroughly executed, the business of planning a strategy may begin.

Many authors writing on strategic planning have suggested that in light of all the factors we have discussed above (the organization, personnel, re-

sources, environment, etc.), we should attempt to identify the “key factors to success” (Kenichi Ohmae, “The Secret of Strategic Vision,” *Management Review*, April 1982, pp. 9-13). Step six, then, is identifying those factors which, when under our control, will assure the successful attainment of the organizational goals. Further, those factors which cannot be controlled (called “limiting factors” or constraints) and ways to overcome them must be identified. This will further increase the probability of success. Ultimately, the organizational goals and objectives must be defined relative to these factors.

**Each strategy statement must include the cost associated with it.**

In our business it seems that the key factors to success are having the equipment the client requires, at a price the client will find attractive, having the expertise to operate this equipment to the satisfaction of the client, and the ability to do all of this in an aestheti-

cally pleasing environment. Obviously this is something of an over-simplification, but may serve as a point of departure for individual planning projects.

### SETTING THE OBJECTIVE

Now we come to the seventh step—setting of objectives. (This will lead to the establishment of strategies for their accomplishment.) Short-range objectives come first and address those things which can be achieved in the next two years. For our business, the short range included some financial objectives, physical plant improvements and market share objectives.

Long-range objectives, which address the three-to-five year period, will include some logical extensions of the short-range objectives, but may also include some new areas. Again, for us, the long-range objectives involved increases in receipts, studio development and improvements, and exploring of some “new markets.”

As with any objective-setting exercise, the caveat must be kept in mind that objectives should be realistically attainable, but ambitious enough to challenge the organization. It is equally important to keep in mind that quantity is

not important; four or five well-written objectives for each of the above categories (long and short range) are quite sufficient.

**Each strategy statement must include the cost associated with it.**

#### STRATEGIC PLANNING

Finally, the strategy may be developed. This is simply a series of statements which articulate how the objectives may be reached. These will be action-oriented statements that include the person(s) responsible for accomplishment. For example, we divided our strategy into three broad areas (marketing, equipment acquisition and physical plant) and then came up with a series of steps under each area which would facilitate the realization of our objectives. Each strategy statement must include the cost associated with it.

So, if an objective of the business is to increase gross receipts by 25 percent for the year, the strategy for accomplishing that might include a marketing function. One part of that marketing may be actively soliciting more demo work from bands by preparing sample tapes to distribute, or developing brochures to place at musical instrument retailers, or mailing newsletters to musicians identified through the American Federation of Musicians. Naturally, raising receipts may involve other kinds of strategies than market-

**We came away from this process with a clearer picture of what we were doing and how to do it best.**

With all of this completed, we placed the entire document into a three-ring binder. To it we added photographs, examples of brochures, business cards, newspaper clippings, press releases, and any other relevant materials. As mentioned at the outset, this package makes an excellent marketing tool for seeking financing. It will explain the nature of the industry in general as well as thoroughly explaining the structure and operation of the particular organization. It demonstrates that the busi-

# Can a Monster Cable really make a difference?

Here are a few people who believe it can.

"We now use Monster on every project to the extent that we would not consider making a recording without them. We've flown Monster Cable all over the world to achieve that goal."

— Jack Renner, The Telarc Digital Label, Cleveland

"If I had one wish, I'd wire every tape machine, every monitoring system, every console — in fact, every recording studio I've ever worked in — with Monster."

— John Arrias, Recording Engineer/Producer, Los Angeles

"It's the only way I can maintain a reference to accurately record, playback, and transfer what is on the tape."

— Ian Eales, Recording Engineer, Los Angeles

"I insist on Monster for all my recordings. It lets me capture all the sound that's missing with other cables."

— Jeff Balding, Recording Engineer, Nashville

"In my 20 years of building recording studios, all the amps, consoles, recorders, loudspeakers — everything I've run across, combined — has not made the difference Monster Cable's wire technology has."

— Ed Bannon, TAJ Soundworks, Los Angeles

"Due to Monster's 'phase-alignment' technology, it was like a mask, a veil, had been lifted from the sound."

— Bob Hodas, Recording/Concert Engineer, Sausalito, CA

"I can't believe that all this time I've been EQing for my cables! Now I'm getting so much sound I find myself using much less EQ."

— Randy Kling, Mastering Engineer, Disc Mastering, Nashville

"It was a little frightening, the difference we heard with Monster Cable. Suddenly the stereo image was better, the tightness of the sound was better, the openness was better."

— Bob Ludwig, Mastering Engineer, Masterdisk, New York

Something's happening here. But this time, it's exactly clear.

At least to the growing number of audio professionals in recording studios, mastering rooms, and feature film sound effects facilities.

They've discovered the significant performance differences Monster makes in their work. And they consider Monster Cable to be a milestone achievement in audio engineering.

They're pioneers. But they were once skeptics. Until they opened their minds to the idea of high-performance cable. And their ears to the sound of Monster Cable.

Now some of them won't even work without Monster.

Must be because of Monster's innovative cable technologies and construction.

Like "Bandwidth Balanced®" multiple-gauge wire networks, "MicroFiber™" dielectric, and "Duraflex®" jacketing.

Each an advanced technology other cable manufacturers can only dream about.

And a 1987 TEC Award winner for Outstanding Technical Achievement in Ancillary Equipment Technology.

So what *is* happening here?

Simple. Audio professionals are beginning to realize that audio cables are not only a critical component, but an essential factor in achieving recording excellence.

The implications for the industry are astounding.

As a panel of audio professionals admitted during the recent

AES convention, once you open your ears, it's very clear:

Monster Cable *will* make a difference in your work.

Take their word for it.

**Monster Cable. Advancing the Art of Recording.**

 **MONSTER CABLE®**

© Monster Cable Products Inc. 1987

101 Townsend Street □ San Francisco, CA 94107 □ Telephone 415-777-1355  
TELEX: 470584 MCSYUI □ FAX 415 896-1745

# TUBE•TRAPS

CONTROL BASS ACOUSTICS

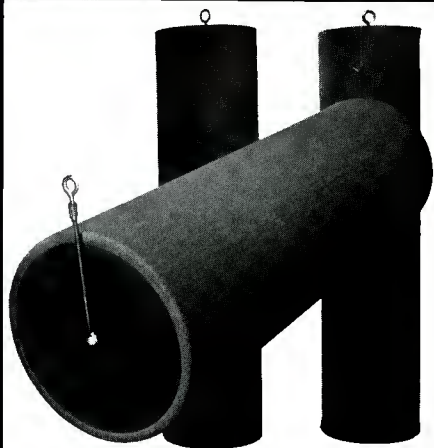

## THE ONLY ACOUSTICAL TREATMENT SYSTEM

- Broadband, Effective 400 Hz, Thru 40 Hz
- Corrects Low End Phase Distortion
- Damps Standing Wave Room Resonances
- Reduces Room Resonance "Q" Response By 4
- EQ's Low End RT-60 Decay Constants
- Packs 15 Sabines Absorption Into Each 3' Tube
- Midrange, Adjustable Diffusion
- Light Weight, Sturdy and Very Portable
- Versatile, Pressure Zone Bass Trap or GOBO

1-800-ASC-TUBE

**ASC** ACOUSTIC SCIENCES CORPORATION

P.O. BOX 11156 EUGENE, OREGON 97440

Circle 19 on Reader Service Card

ness is well thought out and has a definite direction. It clearly shows how certain items and projects will help the business move toward the realization of its goals.

We came away from this process with a clearer picture of what we were doing and how to do it best. We have a prioritized equipment acquisition plan, and a plan for continuing improvements to our studio. Surprisingly, five years after writing our first plan, we are very close to where we wanted to be in 1988. Of course, for the strategic plan to be useful, it must be periodically adjusted and updated. It is worth the effort.

### EQUIPMENT ROSTER

#### Consoles:

Carvin 1688

Biamp 1221

Teac IIA

#### Amplifiers:

Phase Linear Laboratory Standard

#### Monitors:

JBL L110

JBL 4408  
Yamaha NS 10M  
Fostex

#### Microphones:

AKG  
Electro-Voice  
Sennheiser  
Shure  
Sony  
Superscope

#### Headphones:

Pioneer  
Sony  
Koss  
Sennheiser  
Yamaha

#### Outboard processors:

Lexicon  
dbx  
Yamaha  
CBS Laboratories  
ADC

#### Tape machines:

Tascam 38  
Tascam 32  
Cassettes: AKAI, Sharp, Electro-Sync

#### Instruments:

(Guitars)  
Gibson Les Paul Custom (2)  
Fender Telecaster  
Yamaha FG 360 (2)  
Cort bass w/Steinberger tuner  
Gibson ES-335  
Gibson ES-175  
(Amplifiers)  
Marshall 100 watt  
Fender Showman  
Fender Bandmaster  
Sunn Coliseum Lead  
Spectra JMF  
Ampeg B-15  
Fender Vibrolux  
(Pianos)  
Winter console  
Yamaha electronic piano  
(Drums)  
Rogers 5-piece kit  
Miscellaneous synths, sequencers,  
drum machines by arrangement. ☐

## Peabody Conservatory of Music

### Recording Workshops

#### BASIC RECORDING TECHNIQUES

July 4 - 8

(2 graduate credits)

Tuition: \$250

Alan P. Kefauver

#### SOUND REINFORCEMENT AND SOUND SYSTEM DESIGN

Prerequisite: Basic Recording Techniques

July 11 - 15

(2 graduate credits)

Tuition: \$250

John Eargle

#### RECORDING STUDIO AUTOMATION AND MIXDOWN

Prerequisite: Advanced or Multi-track Recording, or equivalent 24-track experience.

July 18 - 22 and 25 - 29

(4 graduate credits)

Tuition \$500/Lab Fee \$100

Alan P. Kefauver

All workshops are M - F 9 a.m. - 4 p.m.  
Recording Studio

#### For further information:

**Peabody Conservatory of Music**

**1 E. Mount Vernon Place**

**Baltimore, MD 21202-2397**

**(301) 659-8136**

Circle 21 on Reader Service Card



# Paramount's Electronic Cottage

**F**rank Serafine has an extensive background in music. His early high school interests led to more serious studies at Ali Akbar Kahn, the College for Indian music in San Francisco, a school co-founded by world-renowned composer and performer, Ravi Shankar. He then went on to study jazz at the Denver University with Gene Rush.

## A SHOPPING SPREE AT THE NAMM SHOW

I conducted a tape interview with Frank while walking the floor of the NAMM

show in Anaheim, California. It might have been the ideal environment because Frank was in the process of shopping for equipment with a gentleman by the name of Bill Childers, who heads the post-audio production department for Paramount Studios.

Sound interesting? Frank is certainly no newcomer to the post /audio world and he is the design consultant to Paramount in the construction of two new post-production audio suites. He has done much sound designing/tracking for motion pictures, television, and radio, not to mention his personal compositional

works which Frank likes to call his *personal music*. Some of his projects have been sound effects (IE *Star Trek I and III, Tron, Poltergeist*, and *Short Circuit*), and others full score orchestrations. Whatever the task, Frank is ready to satisfy demanding markets "one way or another."

## EXPLORATION AND EXPERIMENTATION

What were some of your early exposures to electronics and processed audio? "Well...I always loved my flute (Frank is an accomplished flutist) and when playing in some of my early

---

**I've been with Paramount since 1979. It was in '79 that I did the first Star Trek movie.**

---

journey into the realms of signal processing and discovered that these *outboards* would probably become an integral part of my future musical work. As part of my musical studies I was also required to have somewhat of a piano orientation. The piano was my ticket to a more rounded musical ex-

perience because as a flute player in a band, I was mainly a solo player. The piano enabled me to comp chords and keep up my involvement when there was no solo for me. The piano experience led to more keyboards. Before I knew it, I got a Mini Moog, then a Melotron and on and on."

Was all of this keyboard and synthesizer knowledge from instruction or by

osmosis? "The synth knowledge was actually part of my jazz studies."

Was your compositional experience based in songs or a more stream of consciousness, instrumental line of thought? "I hardly ever did songs. It was usually experimental stuff with no



Figure 1. At the Paramount lot, Frank Serafine poses at right with Bill Childers, Director Post Production (Video Operations Division) at Paramount Pictures Corporation.

bands, I wasn't being heard. This led to the use of a microphone and amplification. The amplification of my flute of course led to the use of effects devices. The first effect for me was echo. I had an Echoplex. Then I graduated to the Space Echo. Shortly after this love affair with echos, I embarked on a long

# Its features are that sounds good

Sony is pleased to announce a merger. Analog recorders that combine the advanced features you need with the quality sonics you crave: the remarkable APR-5000 series.

Whether you need a recorder with a genius for post-production or one for high-quality studio mastering, there's an APR-5000 that fits.

Their 16-bit microprocessor controlled transports handle tape smartly, yet gently. And "intelligent" head assemblies make changing head formats a snap.

And when it comes to sound quality, transformerless design and 400 kHz bias enhance high-end performance. While optional "wide profile" heads create extended low frequency response at 30 ips.

So, if you've been waiting for a precision analog recorder that finally breaks the sound barrier, don't wait. Contact your Sony Professional Audio representative. Or call Sony at 800-635-SONY. **SONY**<sup>®</sup>

Professional Audio



# n't the only thing

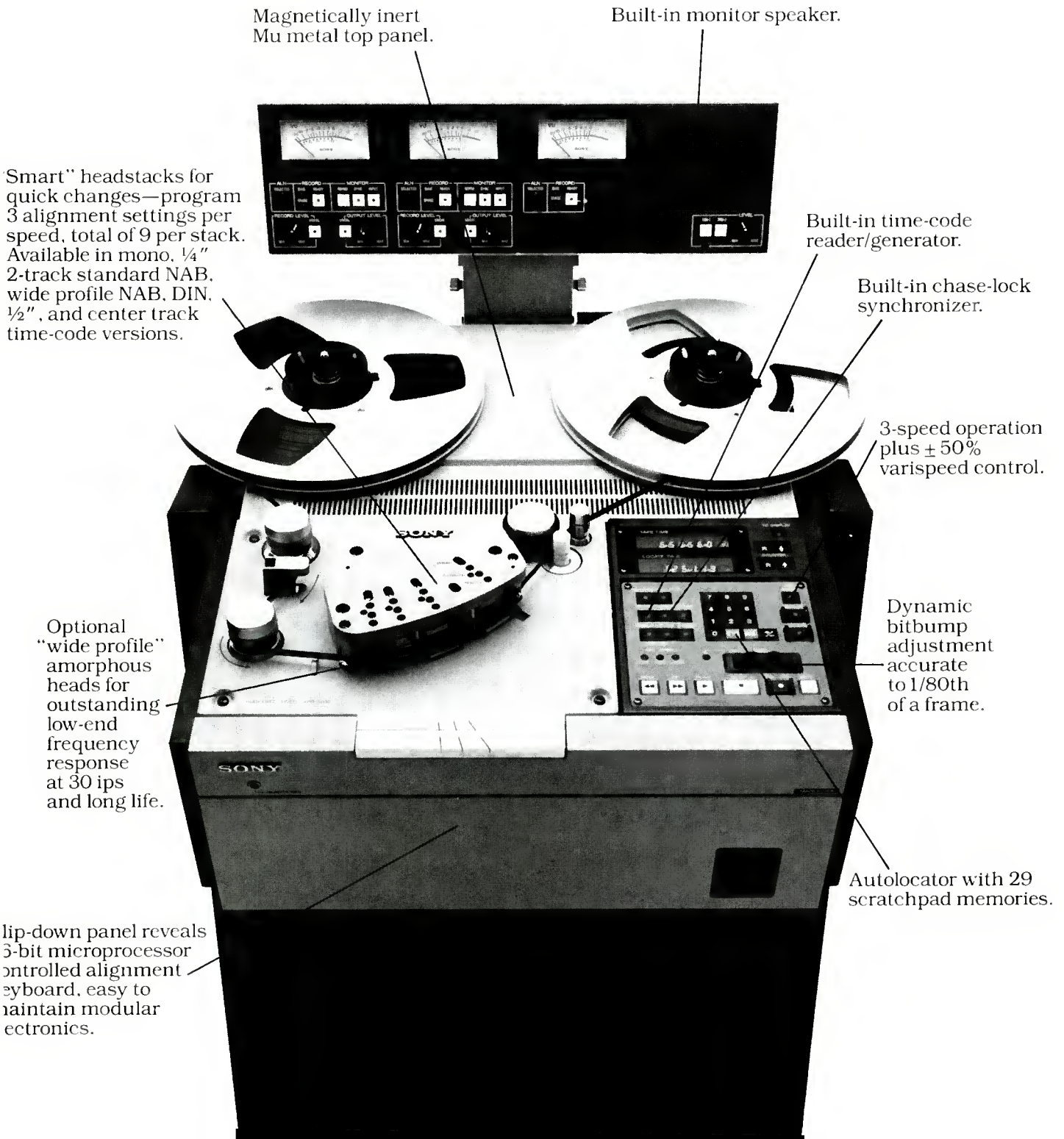



Figure 2. Frank Serafine at his Mac in his studio.

direct message other than to effectively create moods. Of course there wasn't much money to be made playing experimental music, however it gave me the freedom to explore moods...a freedom that lends itself towards creative scoring."

### THE ELECTRONIC COTTAGE GOES TO PARAMOUNT

Could you explain the present connection between you and Paramount? "I've been with Paramount since 1979. It was in '79 that I did the first Star Trek movie. The executives at Paramount have come to recognize me as a high-tech sound designer and innovator because all of the sounds that we had to create were...just impossible. So we always relied on all the technology that was available to help us achieve these monstrous effects. I've always had my ties with them on that basis. They realize that we can create the impossible and they are willing to come to us to have us design the sound systems and MIDI systems for their two new studios."

**I have 18 synthesizers in my room. Each one of them is dedicated to a different instrument.**

"I am probably a prime example of the Electronic Cottage concept in that I live and work at home. I'm bringing

that mentality to Paramount by designing two rooms there that are nearly exact duplications of my studio at home. Those two rooms will be the electronic post-production work stations. The Paramount rooms are actu-

ally scaled down versions of what I have built for myself at home with the hierarchy of control based on the Macintosh computers. The Macs are ideal for Paramount as well as my studio because there is so much Mac out there right now, and they are pretty much the standard in most musical applications. My studio was designed with ease of operation in mind. Although my studio is technologically intense, the processes by which I work are ultimately simple, which, by the way, is the key to a flexible, easy to use, state-of-the-art production facility."

I assume that you are quite at home with technology and that there are no sore spots regarding the fact that your flute might have gotten lost in the shuffle. "Absolutely! I cannot exist without the technical worlds. First of all, I can't afford an orchestra. In effect, I now own a full orchestra. My orchestra has no egos, they're always there on time etc. All my music is done tapeless internally on the Macintosh, then it's digitally mastered on a PCMF-1 (with SMPTE time code) when I'm done."

Figure 3. A history of sampling. The Emulator I on top, Emulator II in the middle and the 16 bit stereo Emulator III below.



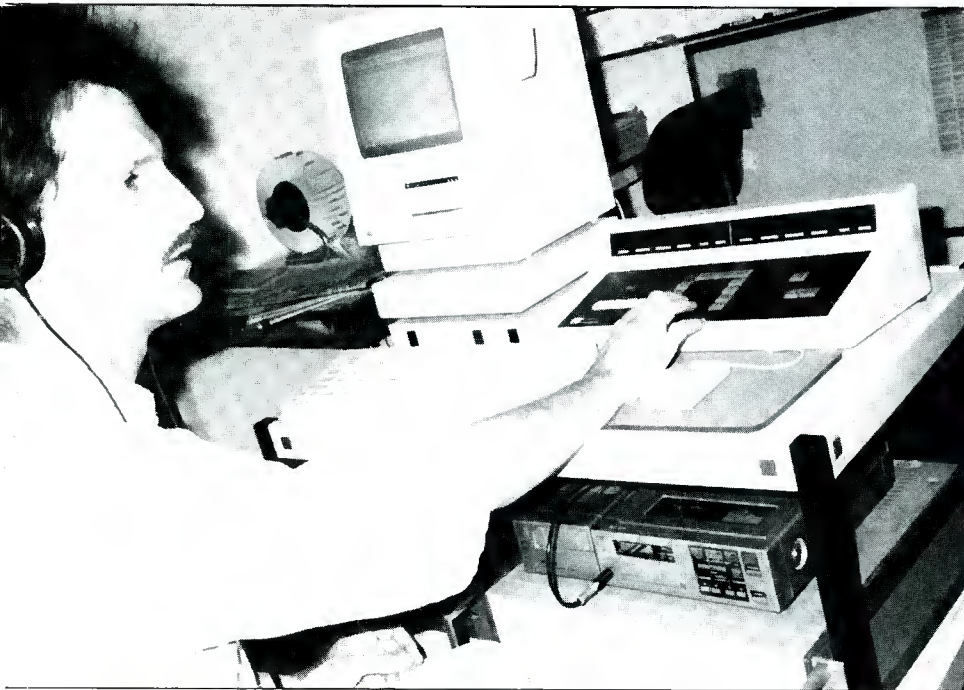

Figure 4. Engineer Rick Schwartz is seen logging at the SE workstation complete with its time code editor and F-1 digital recorder.

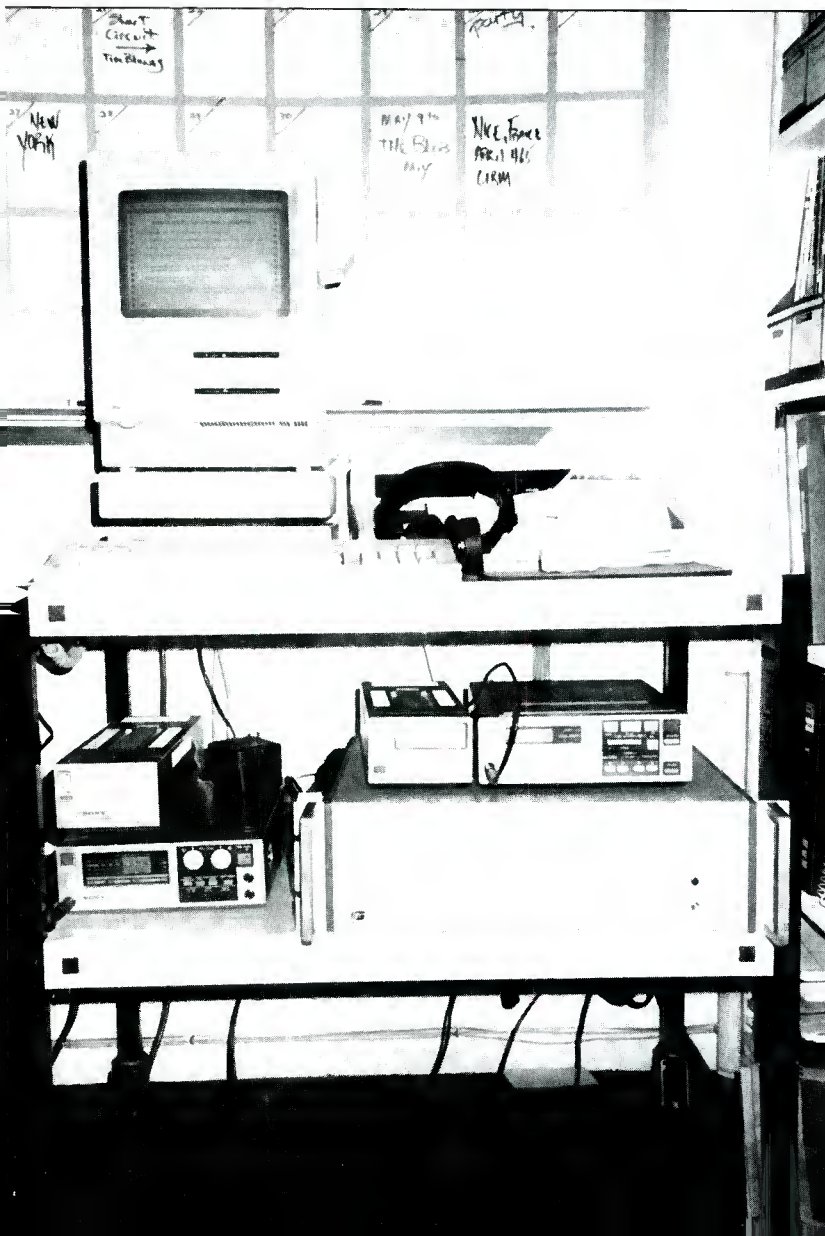

Figure 5. The portable computer work station for Megamix console automation and the sound library database.

## A SPECIAL KIND OF TAPELESS RECORDING

How does your music find its way to the final documentation medium? "Music that I do never touches tape, even when we're done with it. Basically, the music is recorded in MIDI Paint, then laid back onto the PCMF-1. When the music is ready to go to TV or film, that is when it goes to tape."

**The thing is that now there's a program called Multi-Finder that allows you to run five Macintosh programs simultaneously.**

If your music doesn't go to tape until the piece is finished, how many synthesizers do you actually use at one time? "I have 18 synthesizers in my room.

Each one of them is dedicated to a different instrument. The Emulator I is used for, say, cellos. The Emulator II might be used for strings, the Korg DSS1 for horns, DX7 for bells etc. The tapeless kind of recording that I am doing is more easily understood when I explain the equipment's chain of command and the levels of computer control that I'm using. I'm using a MacII, three MacSEs, and a Mac Plus."

"The thing is that now there's a program called Multi-Finder that allows you to run five Macintosh programs simultaneously. An analogy can be drawn between some older conventional sequencers and the Multi-Finder program. On an older hardware-dedicated sequencer, you typically had X number of sequences consisting of X number of notes. Those sequences could be merged to form chains of sequences, that in effect allow the user to get the most use out of the sequencer's memory. Well, the Multi-Finder

program merges, if you will, the Macs in such a way that each Mac can *do its thing* to the highest level of efficiency. When I'm scoring a picture, there usually is a great deal of documentation that is needed. For instance, a programmer comes in and goes through 20,000 sound effects that I have on file, listens to them, grades them (whether they're good or bad), logs them, puts a

SMPTE time code number on their location and logs them in the computer so that I can find them instantly. That logging program is Microsoft Works, a standard data base program. That's what that Mac covers. Now the MacII is in the recording studio, controlling all the synthesizers."

"When I score a picture, I run three programs at the same time. I run MIDI

**I never want to eliminate hands-on control.**

Paint, which is my sequencer. I'm running "Q" which is doing all the clicks and tempo maps, and I'm running MegaMix which is doing MIDI automated mixing. So there are three functions that I need to run at the same time. That's why I have so many computers. The computers are not only documenting sounds and recording events, but they also serve as a musical interface that assist me in my compositional work. One of the many software pieces that I use is a program by Intelligent Music...an interactive compositional program that helps me come up with new ideas. The computer is generating and documenting everything...plus, it's the intelligent interface between me and all my synthesizers. I only play one synthesizer but I control all my different synthesizers from one master keyboard."

#### A NEW MINDSET FOR ENGINEERS

Frank, knowing that you have an engineer who assists you, could you elaborate on what role(s) he plays in your labyrinth of post-production? "My engineer, Rick Schwartz, who used to run the tape machines, is now running the Macintoshes. His job has changed. I believe that the engineer's job in the studio is going to transform. He's no longer going to be a tape operator, as traditionally engineers have been, he's going to be a computer operator. The mistaken fear that many people have about this notion is that they think engineers are going to lose their jobs. I don't believe that at all. The fact is that engineers are going to have to get hip to MIDI because it's where everything is headed. You can now equalize and process sounds internally. That is exactly how we work in my studio. All of the processing, equalization, program changes, dynamics and fader levels, mixing, editing and effects are computer based."

#### ANALOG FUNCTIONS HAVE NOT DIED

Do the outboards that are not externally controllable still have a place in your computer studio? "Certainly. I have a Hill console that has twelve

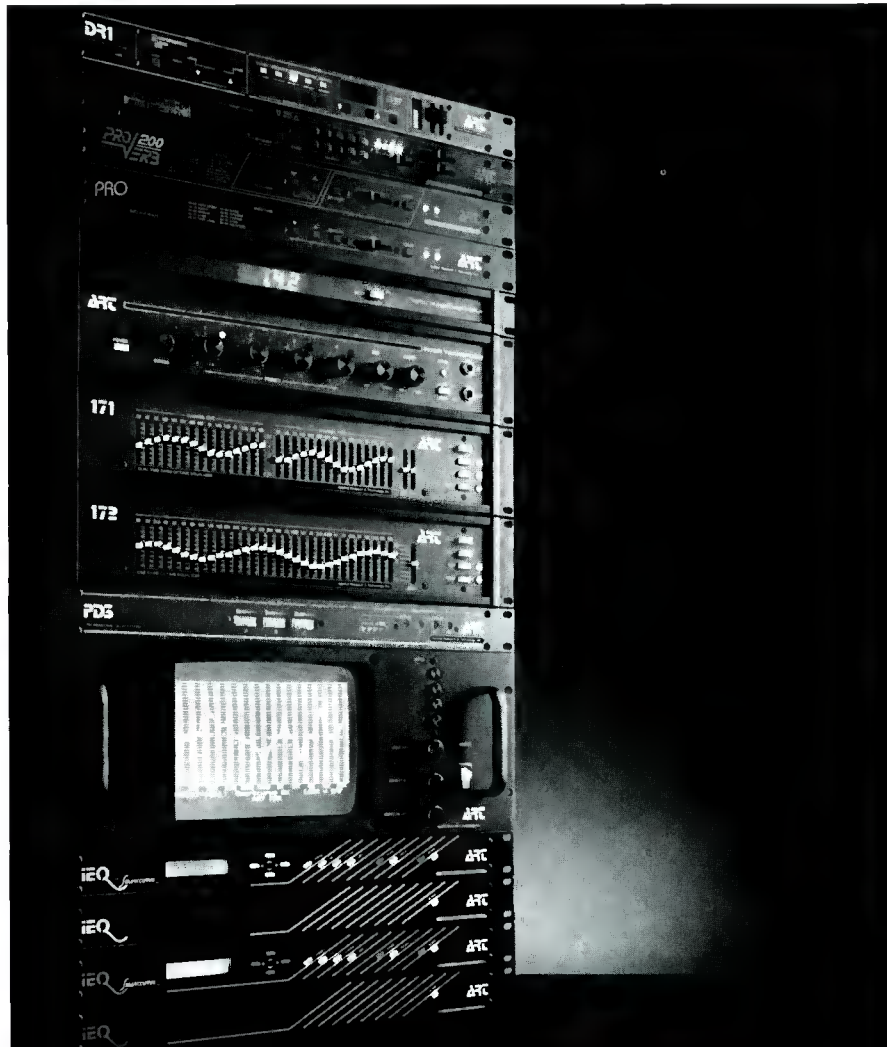

# WORLD STANDARD

AMAZING INNOVATION.  
ASTONISHING CLARITY.  
LEGENDARY DURABILITY.

# ART

APPLIED RESEARCH AND TECHNOLOGY  
215 Tremont Street, Rochester, New York 14608,  
(716) 436-2720, Telex: 4949793 ARTROC, FAX (716) 436-3942

auxiliary sends. Every signal processor that I have is up on the console...which before, I had to patch individually."

Do the analog functions that still exist slow down your working pace? "I never want to eliminate hands-on control. The elimination of the analog world would result in the loss of parameters that are still relevant to the processes of creativity. I use my Minimoog every day. I've had it for fifteen years and it's still there doing things that none of the other synthesizers can do. On the other hand, I'm moving into an Emulator III, which can't do some things that the Minimoog does. The same situation exists with signal processors. My Delta Lab unit can do some things that Digi-Design won't. Traditional recording techniques are still valid in the sense that they help to attain insight into certain processes that still hinge upon principles of acoustics. The same is true for much of the analog equipment that is still out there. An awareness of history can help one to understand trends and what lies ahead in the future."

#### ESTABLISHING A CHAIN OF COMMAND

With an eclectic array of synthesizers, processors, and recording equipment such as yours, that aren't all digital or all analog, don't you encounter problems with incompatibilities? "Well...yes, but I have spent much time investigating solutions to those problems. Although I have a PCMF-1, which by the way is a superb machine, I also have analog tape machines in order to deal with the kinds of problems that you just asked me about. To synchronize all of my digital and analog machines to video, I have designed a production chain that is working very well. In the

way that I use analog synthesizers to enhance digital samplers, I use analog tape machines interlocked with video. My master video machine is a Sony 5850 that works in conjunction with a Sony VO2600. The master tape deck is the Sony PCMF-1 which is interlocked to a Betamax SLO420. A Fostex two-

track with center track time code is the master quarter-inch machine. For broadcast and film, the final tape format is usually quarter-inch. Incidentally the film world is predominantly analog, however there's a lot of digital hybridization creeping its way into that area." db

## PROFESSIONAL PRODUCTS by Soundcraftsmen

...our 20 years experience building high-powered Professional amplifiers right here in Santa Ana, California, assures you of Reliability and Direct Factory backup!...

The new "X2" Studio Monitor Amplifiers were designed for those applications where *sonic accuracy* is the utmost goal. MOSFET output stages provide Ultra-High-Current capability for easily handling low impedance loads...As with all Soundcraftsmen amplifiers, circuits are designed with absolutely no current-limiting, thus eliminating the harsh clipping characteristics associated with current-limited amplifiers...

The PM860X2 Multi-Channel amplifier has 4 channels at 315 watts each into 4 ohms.

The 200X2 is rated at 145 watts per channel into 8 ohms, 210 into 4 ohms.

The 450X2 delivers 210 watts per channel into 8 ohms, 315 watts per channel into 4 ohms and 450 watts per channel into 2 ohms. THD is less than 0.05%.

The 450X2M is the same as the 450X2 plus calibrated LED metering.

The 900X2 delivers 400 watts per channel into 8 ohms, 675 watts per channel into 4 ohms, 900 watts per channel into 2 ohms.

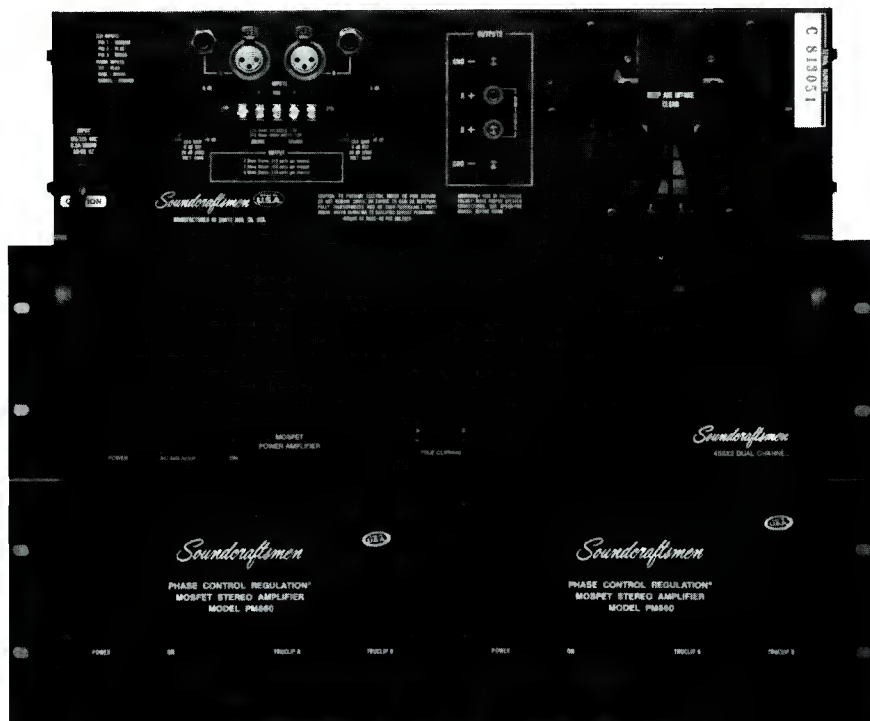

2200 SO RITCHEY • SANTA ANA, CA 92705 U.S.A.

**Keep your working parts in order.**

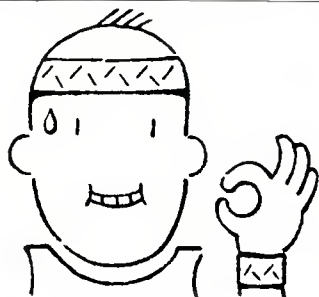

 **American Heart Association**  
WE'RE FIGHTING FOR YOUR LIFE

Circle 23 on Reader Service Card

## THE VU METER AND THE PEAK-PROGRAM METER

• The advent of broadcasting and networking brought with it the need to monitor and supervise audio program levels, which immediately produced a plethora of different audio level measurement devices, developed by various organizations engaged in the transmission and broadcast of audio program material. When these organizations sought to exchange audio programs, the incompatibility between their various measurement devices quickly provided a lesson in the need for standardization.

The dynamic characteristics of an audio level meter determine its unique response to audio program signals.

### AN INTERNATIONAL STANDARD

Last time I described the process by which the vu meter became the standard audio program level meter for the United States in 1939. In 1988, broad-

casters are still using the vu meter as it was defined in 1939, and is currently specified in IEEE/ANSI 152-1953, reaffirmed in 1971, "Recommended Practice for Volume Measurements of Electrical Speech and Program Waves."

Shortly before the vu meter was adopted by United States broadcasters, their European counterparts had decided upon the peak-program meter. The ppm does not enjoy the degree of standardization that the vu meter does; several sets of ballistics and numerous different scales are in use.

The confusion that results from the use of audio level meters possessing different ballistics and scales at each end of an audio program circuit moved the European Broadcasting Union to specify a standard peak-program meter for international program exchange. This ppm is specified in EBU-3205, 2nd Edition, issued in 1979, and is not intended to replace any meter used internally by any organization. It was recognized that agreement could not be reached on a common meter and scale to replace those used by various organizations, nor would this necessarily be desirable. The requirements for a meter used in a studio control room are not necessarily identical to those for an instrument used to set and control international program levels.

### REVIEWING VU

The vu meter consists of three basic parts: a network, which may be a fixed or variable attenuator or a gain-supplying stage; a full-wave rectifier; and an indicating device.

The vu meter presents a "bridging" impedance to the circuit it is measuring. 3900 ohms of resistance and a full-wave rectifier are incorporated within

## Goodbye Noise!



Nobody does it better when it comes to tape noise reduction. Our **SYSTEM ONE**, Encode/Decode **MODEL 180A** provides incredible results with no side effects for under \$700.

- Effective noise reduction of 30dB plus 10dB headroom.
- Provides dynamic range better than digital.
- Totally transparent system.
- No side effects (such as "breathing").
- Fully simultaneous encode/decode.
- Also available in four channel (140A) and two channel (120A).

Take advantage of our **PATENTED** technology and improve your recordings. Write us for more information on our **SYSTEM ONE** units, or see your Rocktron Dealer.

 **ROCKTRON**  
CORPORATION

1633 Star Batt Drive  
Rochester, MI 48063  
(313) 853-3055

the meter itself, while 3600 ohms is provided externally in the associated network. The combination of meter and network presents an impedance of 7500 ohms, which is 12.5 times a circuit impedance of 600 ohms, and imparts the proper ballistic characteristics to the meter. The reading in vu is the algebraic sum of the meter indication and the setting of the network, which as stated earlier may be fixed as well as variable.

The vu meter has a standard scale which displays -20 to +3 vu logarithmically. The portion of the scale from -20 to 0 vu may also be accompanied by percentage markings from 0 to 100. The peak-program meter may have one of a number of scales, many of which, including the EBU standard ppm, display 24 dB in decibel-linear increments of 4 dB.

#### SAME AUDIO, DIFFERENT RESPONSE

The dynamic characteristics of an audio level meter determine its unique response to audio program signals. The vu meter's response time is defined as the time its pointer takes to reach 99 percent of reference deflection after sudden application of a sinusoidal voltage of 35 Hz to 10,000 Hz of sufficient amplitude to give reference deflection under steady-state conditions. This response time is specified at 300 milliseconds. Upon such sudden application, the meter must overswing reference deflection by not less than 1 percent nor more than 1.5 percent. The time required for the indicator to fall back to the no-signal position after the signal is removed must not differ greatly from the response time. The meter's integration time is 150 milliseconds, and for a mechanical D'Arsonval movement is determined by mechanical structure of the meter itself. For an electronic realization, of course, the integration time must be produced electronically. A final requirement that the meter's response be independent of its polarity in the circuit is achieved by full-wave rectification of the audio signal.

#### PEAK DYNAMICS

The dynamic characteristics of the peak-program meter cause it to respond quite differently from the vu meter to the same audio program

---

### ...each syllable or word of a speaker will be displayed as a bounce of the needle.

---

material. The ppm requires an associated electronic unit which determines its ballistic characteristics. The ppm typically presents an impedance of at least 30,000 ohms to the circuit it is measuring.

The EBU ppm's delay time, corresponding to the vu's response time, is 150 milliseconds, and it must overswing its steady-state indication no more than 0.5 dB. Its integration time is 10 milliseconds, and return time is 2.8 seconds. Return time is the time after removal of a sine wave causing deflection to the mark 12 dB above the meter's "test" or midpoint that it takes the pointer to reach the mark 12 dB below "test."

The 150 millisecond integration time and the 300 millisecond rise and fall times of the vu meter cause it to have an averaging action in which a number of audio program peaks will be integrated. Its response is "syllabic" in nature, that is, each syllable or word of a speaker will be displayed as a bounce of the needle. The peak-program meter, on the other hand, has a fast rise time and a very slow fall time, giving it a "sample and hold" type of action. Its 10 millisecond integration time gives it a quasi-peak response: any peak longer than 10 milliseconds is fully displayed, but those shorter than 10 milliseconds are displayed to a lesser degree. The integration time was based on research which demonstrated that peaks of less than 10 milliseconds duration could be clipped without audible consequence.

#### DIFFERING ALIGNMENTS

The differing dynamic characteristics and scale philosophies of the vu and peak-program meters require them to be aligned and read differently. The dynamic response characteristics of the vu meter cause it to "ignore" about 6 to 15 dB of audio peak material. The actual amount of peak material not displayed varies with program content, being generally greater for voice and less for material containing few transients. Research and long experience have shown that a good average figure for this undisplayed peak material is

about 8 dB. The vu meter is aligned with reference-level tone for deflection to the "0 vu" point. It is operated with audio program to this same point, with the understanding that an average of about 8 dB and a maximum of about 15 dB of peaks are present above those indicated.

The peak-program meter, while not indicating true audio peaks, comes much closer to being a peak-reading device. Any ppm using a scale of 24 dB in 4 dB increments is aligned to its midpoint or "test" mark with reference-level tone, and operated with audio program material at a mark either 8 or 9 dB above this point, with the understanding that true program peaks may be up to 6 dB higher than those indicated. It is interesting to note that for either peak-program or vu meter, there is consensus that true program peaks reach a value about 15 dB above the point indicated by a reference-level sine wave.

#### A COMBINATION OF METERS

Both vu and peak-program meters have been used with equal success to control audio program levels for the past fifty years. It can be beneficial to use a combination of vu and peak-program meters on the same program line, because of the different type of information each conveys. When set up properly with alignment tone, the two meters, with their different dynamic characteristics, will not track each other on program material, but will differ in their response depending on such characteristics of the program material as its peak-to-average ratio. In the hands of an operator who understands them, the two meters used together can be quite informative about the nature of the audio signal.

References have been made to "meters" and "pointers," but nothing said here is intended to preclude the use of non-mechanical indicators such as light-emitting diodes or gas-discharge displays. After all, this is the electronic age! Electronic indicating devices may accomplish exactly the same objectives as mechanical meters, if their electronic circuitry gives them the same static and dynamic characteristics as their mechanical counterparts. □

# LA Broadcasting

*KSLA-TV is located in Shreveport, Louisiana—a medium market, where it is common to make full use of the facilities by doing both local award-winning commercial production, as well as news programming and entertainment shows.*

What this means is that equipment must be capable of 1) quality work—fast, and 2) lots of “bells and whistles.” With this in mind, the audio department invests in gear such as the SPX 90 by Yamaha, which can easily alter the voice of a news subject who wishes to remain unidentified, and just as easily provide a multitude of effects for commercials.

## STOP THE STACKING!

In the past, as new equipment was added to our audio booth, it was carefully stacked on top of the meter bridge of the console, due to insufficient rack space. This arrangement was at least acceptable, until we acquired our second 4-track open-reel recorder. The practice of stacking new gear had to stop here! Trying to find a place to put the new machine led to completely remodeling the room.

I began by measuring *everything*—exact dimensions of equipment, including length of existing factory cables, space required for connectors, and for heat dissipation. As I drew one scale drawing after another, I asked for input from those who had experience working in such a facility, and consulted with engineering frequently to see to it that potential problems were solved before construction began. Chief Engineer Jim Womack was quick to point out the advantage of easy access to the rear of the rack, a feature the previous arrangement did not include, so I arranged the floor plan to allow for this, and incorporated easily-removable doors into the rear of the custom-built rack.

We constructed the rack of 3/4-inch plywood, which we knew from experience would not withstand the weight for any length of time without sagging in the middle. Angle iron reinforcement was added and bolted to the channel iron which provides three rows of vertical rack space. Positioning the rear of the rack assembly to face the doorway serves as a barrier, isolating the talent/mic area at the front of the rack, from the entrance which opens into a noisy hallway. This barrier was then covered with the thickest SONEX available. Further sound-tightening is provided by sand-filled walls, an effective feature inherited from those before me.

## CUTTING INTO WALLS

Early planning included the prospect of retiring each of the old tape transports, including the MCI 4-track. After

*Ralph Mitchell is the Audio Director for KSLA-TV in Shreveport, LA.*

## Don't even think about another automation system.

Listen to the opinion of the professionals:

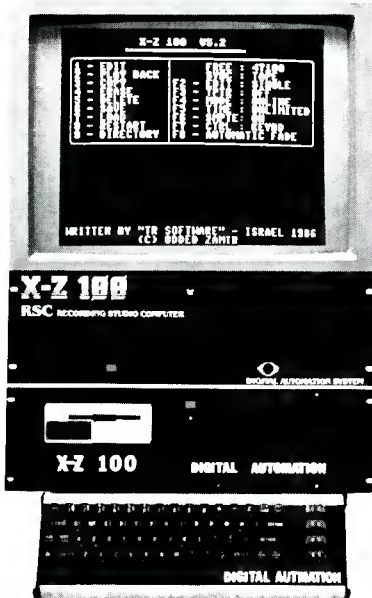

- “The XZ 100 is easy to learn and use. The sound quality is all you could ask for.” *Craig Anderton, Mix Publication, Feb. 87.*
- The XZ 100 is a stunning example of human ingenuity. It is everything it claims to be.” *Drew Daniels J.B.L. db Jan. 87.*
- “The XZ 100 is easy to learn, reliable and quiet, it was a perfect choice.” *Professor Ves Bennett, University of Washington D.C.*
- “The XZ 100 can increase your studio's production efficiency while greatly improving the quality of your work.” *Guy Defazio, University of Miami in Field Test for Mix Magazine.*
- “I realize the XZ 100 is equal or superior to many of the ONBOARD automation systems I have used.” *Keith Morrison, db, Nov. 87.*
- “The XZ 100 is a terrific mixing tool.” *Tony Moskal, Legacy Music.*

Now available in a rack mountable dedicated system with a 3½" disk drive and a light weight remote computer's keyboard. Other options include an endless loop digital fader, auto noise gate, mouse controller, and much more!

## Retrofit your mixing console. XZ 100 + You = MIX-POWER

Update your studio and jump into the new generation.

XZ 100 - the ultimate in mixing automation for any console.

### Kia Electronics

Marketing: 7393 S.W. 42nd Street, Miami, Florida 33155 (305) 264-7017.

Development & Research: 16740 S.W. 301 Street, Homestead, Florida 33030

Circle 25 on Reader Service Card



some discussion with production department manager Roger Herring, we decided that synchronization of audio to video for full-length production is essential, so we made room for the MCI (with SMPTE time-code capabilities) in the wall. The wall chosen, fortunately, was not a sand-filled partition. Its adjacent room is a quiet, telephone equipment room. We found as we cut the wall that my predecessors had provided us with a triple wall between the two rooms. As it turned out, this eased the job of mounting the machinery. The depth of the machine is almost exactly the same as the wall, so construction of a support system was not necessary.

Most of the project was accomplished during normal business hours with the valuable assistance of KSLA's maintenance superintendent, Max Hall. With years of experience, ranging from news set construction to editing suites, Max saw to it that the construction of each unit is sturdy and functional. After months of rushing to the shop between clients, and then greeting them with contact cement or paint on my hands, the preliminary work was complete. We scheduled the shut-down and dismantling of the old room towards the end of the work-week and spent the weekend putting all the new cabinetry in place. The following Monday, engineering began the three or four day process of tying all the pieces back together.

**Keeping up with the needs of outside clients, as well as the demands of in-house projects assures ever-changing requirements of the system.**

The arrangement of the equipment in the rack (which is suspended in front of the operator, over the console) is dictated by frequency of use. Often used gear, such as the auxiliary mixer, the SPX 90 and the reverb unit, is directly in front of the operator, and the "set-it-and-leave-it" gear such as DAs are more out of reach—either toward the top, or the right-hand third of the rack. The Otari 5050 reel-to-reel is used primarily as a slave for dubbing down final stereo mixes, so it sits in the left-hand third, out of the way of the creative process. I still do most of my music



Figure 1. Engineer Jim Womack and the author. The equipment is dedicated to its location according to its frequency of use.

editing manually, although we have electronic editing capabilities. The old Scully "work-horse" handles this task. It is located to the right of the operator on a slight angle and with plenty of leg space underneath, as comfort is a must in long, tedious editing sessions.

#### COSTS

The entire project was done by the KSLA staff, so the cost in labor was minimal. The bottom line on building materials came to just over \$1,000.00.

This includes all hardware, paint, glue, formica, lumber and the single most expensive purchase order—SONEX, which was used on the entire rear of the rack, forming a wall of foam. To look at it, one would never know that any seams exist in that wall. Cutting of the SONEX for the rear access ports was carefully accomplished by the making of a full-size template, and cutting with an electric knife—a *must* for installation of the otherwise difficult material.

Figure 2. The new audio booth design at KSLA-TV.

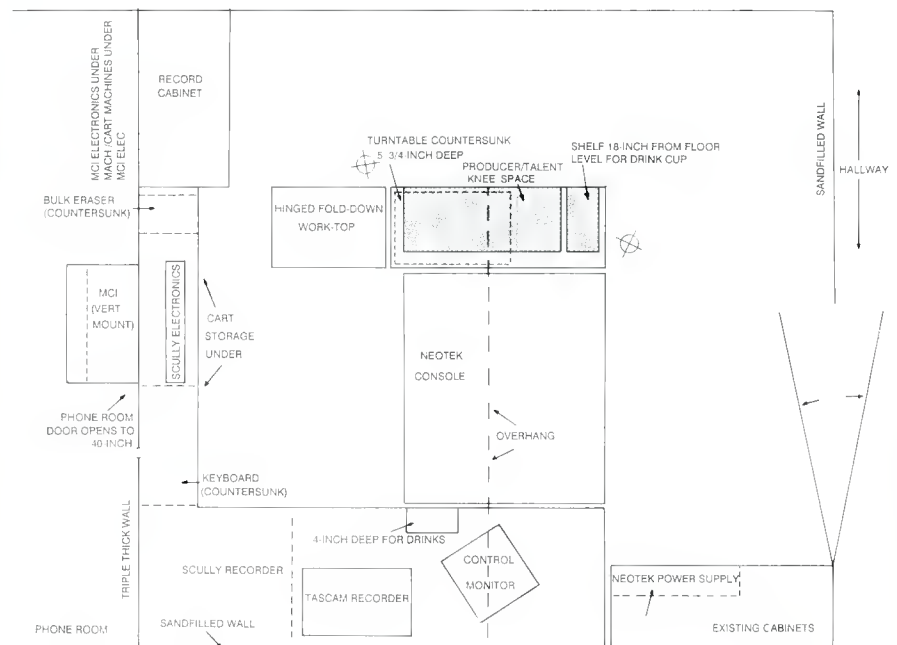

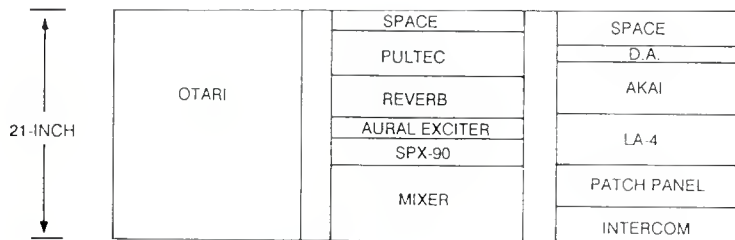

Figure 3. The rack overhang elevation.



Figure 4. The author is seen finishing the front of the new rack. Steel reinforcement was added to withstand the weight load.

voice bed cut in the audio booth transferred direct from master to 1-inch work tape via cables crossing the hall. As video editing takes place in post-production, sfx and music are laid in on the 4-track master in the audio booth, and ready for re-transfer to the 1-inch tape in time for the final pass to 2-inch video tape. This is easily accomplished, as the output of the audio booth feeds a D.A. into the video post-production facility. This means one less dub to make, hence higher quality, plus more efficient use of time. The outputs of each track of the MCI also feed separate channels of the mixing console in the computer editing suite, so audio mastered on that deck can be mixed as necessary in editing.

Keeping up with the needs of outside clients, as well as the demands of in-house projects assures ever-changing requirements of the system. Plans for further improvement include a new console, and new sound effects discs have been ordered to aid in the creative process. Other changes are certain as market conditions warrant, and with technology moving ahead at warp speed, who knows what gadget we'll be lusting after next!



#### EQUIPMENT LIST

Neotek 10 x 4 x 2 mixing console  
 Tascam M-1 B mixer  
 MCI JH110B 4-track recorder  
 Tascam 44 4-track recorder  
 Otari MX 5050 stereo recorder  
 Scully 280 mono recorder  
 Panasonic cassette recorder  
 Technics SL-P520 digital player  
 Technics SL-1200 MK2 turntable  
 Yamaha SPX-90  
 Aphex Aural Exciter  
 Master Room XL-210 reverb  
 Pultec eq  
 LA-4 compressor/limiter  
 AKAI monitor amp  
 Cerwin Vega monitors  
 Ward Beck intercom  
 Radio Systems D.A.  
 ATI D.A.  
 ITC PDII cart machines  
 ITC ESL-IV splice locator  
 Casio sampling keyboard  
 Fostex, Sennheiser, Koss headphones  
 AKG 414 microphone  
 Sennheiser 421 microphone

#### THE CONSTRUCTION

The actual construction took about 3-1/2 to 4 months, working as time permitted between sessions. Now that it is complete, we can more readily compete with other studios who do television and radio production. Clients range from those who just need to tag a spot, to audio-visual presentations, multi-image slide shows, and music videos. Our small audio crew serves as a service organization to a) the news department, b) the production department, c) the sales department. Luring outside clients in for production other than in-house projects keeps me busy, and often requires back-up in post-production by assistant audio director, Jim Nelson.

Clearly, our advantage in the market is convenience. A client, who for example gets late copy approval, can get started in post-production with a dry

The old air supply came from a system which cooled and heated adjacent offices, so in the winter the heater made the booth rather uncomfortable. The only way to avoid this client-annoying problem was to keep the hot incandescent track lights off, and the noisy florescent lights on instead. Luckily, as this project was nearing an end, the station opted to upgrade its phone system. The new mainframe needed a constant cool air supply, so cool air was diverted from the nearby duct feeding master control into the phone room and adjacent audio booth. At the time of this writing, problems exist with an excessive volume of air rushing into the room, causing wind noise, not to mention icing of the fingers! One possible solution under consideration is relocation of the fresh air duct to the back side of the rack.

# Sound Reinforcement in South and Central America— Part II

*This issue, our travelling sound man is off to Brazil, where he says he always wanted to go.*

**F**riday, March 20, was a day I had been looking forward to: I was finally going to Brazil, a place I'd dreamed of visiting all my life. We left that afternoon around 4:30 after surviving a very chaotic baggage check-in and emigration clearance: understaffed airline and customs desks were swamped by impatient crowds. Although we had allowed 2-1/2 hours, we barely made our plane. Our flight made one stop at Iguazu, which gave me a gorgeous view of the

conveniences. Jeff Murray and Maria Estella Correa, our USIS control officers, were waiting, and helped us transit Brazilian immigration. This involved checking our working visas (all foreigners working in Brazil MUST have work visas) and inspecting our personal baggage very closely. Surprisingly, the only equipment they wanted to see was my SPX-90. During the 40-minute drive into town, Maria and I discussed the sound system arrangements; two different sound companies would

ian music; both felt that Brazilian audiences would relate well to the band because of these similarities. Our first performance in Brazil would put that theory to the test: we were sharing the venue with a popular local pop-rock band. They played at midnight; we would perform a special "pre-concert" concert at 9pm. Jeff and Maria hoped that this combination of groups would garner a good crowd for us.

Lee and I were picked up at noon Saturday and taken to the SESC, a giant arts complex in São Paulo. Our venue, the SESC-Pompeia Theater, had a unique configuration: a centrally located stage with two raked audience seating areas on either side. A small balcony surrounded both stage and audience areas (*Figure 1(A)*). Essentially a concrete rectangle with hardwood seats, the hall's reverb time was around two seconds and radiated harsh reflections. The PA system was provided by SK Som, a local sound company contracted by the headliner to handle their week-long engagement here. System owner/engineer Sergio Korsakoff and I huddled to discuss production needs and scheduling with the guys from the Brazilian band: my goal was to change as little as possible, keeping them happy, yet get everything we needed, keeping me happy. We agreed that the Zydecajun band would use their own amplifiers, with my microphones and DI boxes, but would share the drum set and drum mics, which was fine with Troy. As we worked it out, the only things that had to move were mic stands and a keyboard rig. We set our amps in front of the other group's amps, and still had lots of stage space. SK Som had a discrete monitor system, capable of 8 mixes; the Brazilian group used 5, so I used the open 3. The monitor engineer could leave his preset levels alone, yet still give us whatever WE needed. Working within the confines of existing

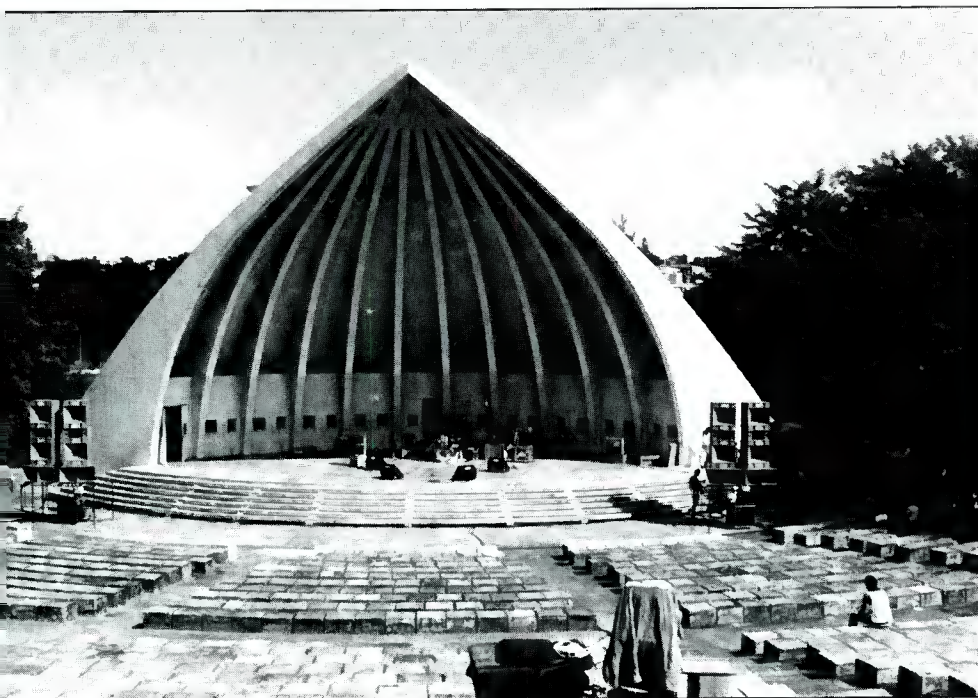

*Figure 1(A). The bandshell in Taquaral Park, Campinas, Brasil.*

famous cataracts and falls of the Iguazu River. Flying into São Paulo at night gave me a true impression of how massive it really was; at 15 million, it's the most populous city in South America. The airport was brand new and had all the modern

handle the shows, one here and one in Campinas.

Our hotel, the Maksoud, was fantastic; once checked in, we stayed and enjoyed a light dinner with Jeff and Maria. They spoke at length about the relationship of Cajun music to Brazil-

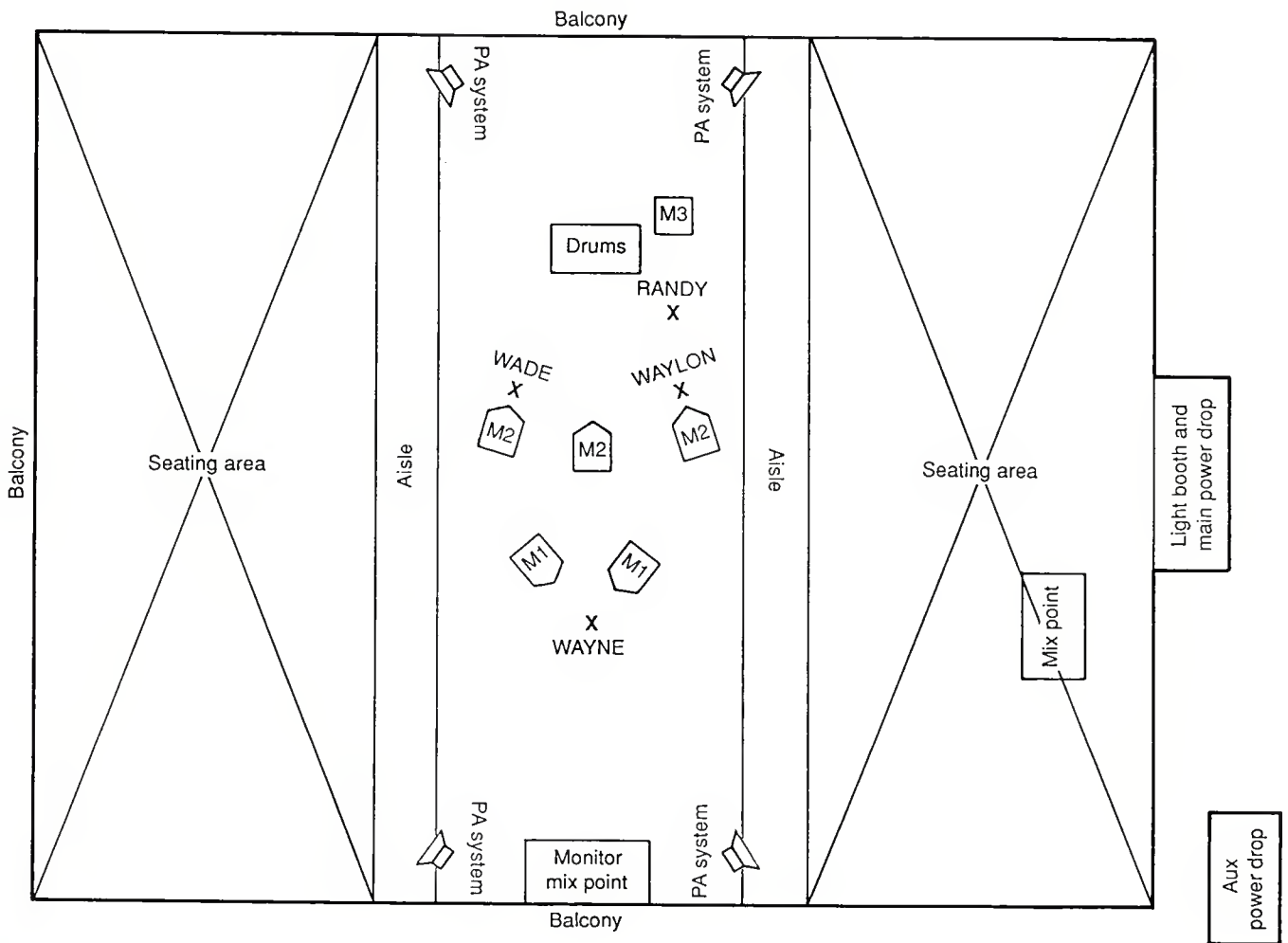

Figure 1(B). The mic layout at the bandshell.

monitor speaker placement and assignment, I was able to devise a system for us that Wayne and the band loved (Figure 1(B)). One mix serviced Wayne only; another covered the three "string instrument" players; the third was dedicated for Troy. It was the first time the group had ever played "in the round," so we changed our setup slightly: we had Wayne face the band instead of our normal style of band behind, where he would have faced a wall. The guys were eager to get started, but we had a problem with a.c. power for our gear: it proved to be impossible to find a functional equipment ground and a clean neutral at the drop point provided. We did what sound check we could without amps, and I sent the band back to the hotel. They would return later, when we'd have a regular check just before the house opened, power permitting.

#### TRACING POWER LINES

I began to trace power lines with Sergio and the house electrician, spending a frustrating 1-1/2 hours testing various drops and outlets. There was no

ground accessible anywhere in the hall, and the neutral carries as much as 50 V in places. I finally insisted that my transformer tails be tied directly into the main house drop, located in the light booth behind the house mix point. I found a service here with 220 V/leg, a clean neutral, and (hallelujah!) grounded conduit, to which I attached my equipment ground. My efforts were soundly rewarded: my DIs were quiet, while SK Som's had varying degrees of hum and buzz. Sergio was impressed; we spent the rest of our time talking shop, especially grounding, while I tuned the PA and monitor systems, which would prove to be the best I'd see on this tour. The house stacks were 4-way electronic: 1 15-inch, 2 12-inch, 1 90 degree radial with JBL 2440 driver, and 2 bullet tweeters comprised each "stack."

---

**The band slammed through the material with the impact of a runaway train**

---

There were two types of monitor wedges: each contained an elliptical horn with mid compression driver and a bullet tweeter, but one utilized a single 15-inch woofer, the other had 2 12-inch woofers. There was a large tri-amped drum monitor available, but I elected to use a wedge instead to cut down on the problem of monitor bleed in the drum mics, an important consideration in this very live room. A Yamaha 2408 monitor console fed DOD 1/3-octave graphics and Polyvox (Brazilian-made) amplifiers. House gear included Yamaha 2031 1/3-octave graphics and Rane 4-way crossovers, fed by a Yamaha 2404 console. The effects compliment contained Yamaha REV-7 and SPX-90 reverbs, Roland DDL, Furman parametric equalizers and noise gates, and a dbx 166 gate/limiter. Doors opened to the public at 8:15pm, so when the band returned at 8, we really had to hustle. I concentrated on the house mix, while Sergio and Wayne worked with the monitor engineer to refine the stage sound. We were able to get things in the pocket within the allotted 15



Figure 2. House-right PA stock at Taquaral Park.

minutes, although I did work on some drum reverb effects with Troy while the crowd began to file in. We started promptly at 9, and played until 10:15. The audience was on their feet, dancing and partying, after only three songs, and Wayne changed the set list to keep the heat on. The band slammed through the material with the impact of a runaway train; Wayne was all over the stage, dancing while he played, whipping the crowd into a frenzy. The near-sellout crowd helped damp the room reverb to the point where I could push the PA more than I had during sound check, and I took full advantage of the three reverbs, dedicating one to vocals, one to solos and one to drums. I went for a big sound, and judging from the passionate audience response I can say we achieved it. I received a silent compliment when the Brazilian group's sound man copied my reverb settings for his band! After signing autographs for almost a half-hour, we finally returned to the hotel for dinner and congratulations. Jeff felt it was the best response he'd ever had for an American group; Maria translated the crowd's praises into English for us. Our visit to Brazil was off to a fantastic start!

### MORE PA POWER

Jeff and Maria arrived at the hotel Sunday at 11am sharp, and we drove the 1-1/2 hours to Campinas. We were scheduled to play an outdoor concert in Taquaral Park, at the Acoustical Shell: a stage covered by a huge bandshell, it played to an audience area with seats for 4000. The weather was perfect, the local staff helpful, the PA already in place and working (Figure 2). Maria had successfully communicated my power requirements to the local electrician, who tied me in on a back-stage service, and procured a ground from an adjacent water pipe. What more did I need? More PA power. The house system provided was rated around 2500 watts, nowhere near enough to fill an area of this size outdoors; I felt a little better when informed that we'd probably only get 1500 people. We sound checked briefly, then covered things up and relaxed until our concert started at 5pm, sparing us the worst of the sun. The local sound guys had been playing music for about an hour, drawing a small crowd. At 4:30, I put on a tape of Wayne Toups; people started stream-

Figure 3. The house PA cabinets at the National Theater, Brazilia, Brazil. The cabinet to the left is the one used by the author, the one to the right is the original one which he rejected.



ing in like mad. Just before the band hit the stage, we had a crowd of close to 4000, including the park director who wanted to see what was causing the commotion. My biggest mix priority now was to ensure that EVERYONE hear the vocals, and my PA/crowd size situation wasn't favorable: this system would only get so loud before it clipped. I didn't want the band to sound wimpy, either. The shell did project a moderate amount of stage sound, so I suggested that the guys open up their amps a bit more than normal, especially bassist Randy Ledet. I could now keep the PA mix vocally dominant, adding just enough instrument and drum levels to raise solos and round out the ensemble sound. The crowd at the shell was fairly reserved, although a few people danced. Soon, a lot of heads nodded and toes tapped. When Wayne and the band broke smartly into "Zydeco Shoes," a man ran up out of the audience, grabbed Wayne's vocal mic, and spoke one sentence in Portuguese. The place broke up, and by the end of the tune, over half of the audience was dancing like crazy. The apron in front of the stage was packed with dancers; Wayne plunged into this mass while playing several times, to the delight of the crowd. It didn't stop until an hour and two encores later. The band again enjoyed the crowd's attention after the show, autographing programs and T-shirts. On our way back to São Paulo, Maria confirmed that no one knew who our "mystery MC" was, but translated his announcement: "this song is good for dancing." It was, and they did!

Monday, March 23, called for an evening concert in Brasilia, so we'd have to catch TransBrasil's Morning flight. This posed two problems: dealing with formidable São Paulo rush-hour traffic, and handling the transferal of our equipment. With a concert scheduled the same night, we could afford no slip-ups in the transportation of our gear. A 6am pickup of bags and equipment from the hotel storage room was arranged; this combined load was taken over early to the TransBrasil cargo center and placed in a single container, ensuring that all our stuff would travel together. We followed at 7am to allow plenty of time to fight traffic. Lee and Jeff adroitly handled equipment and personnel check-in, and the 1-3/4 hour flight to Brasilia allowed us glimpses of the country's interior. Upon arrival, I was permitted to go back into the airport luggage area, where I supervised

separation of our stuff. Equipment would be sent directly to the hall, baggage to the hotel. The drive to the hotel allowed a look at Brasilia: the capital of Brazil, it was a very modern-looking city, as most of it had been built in the last 25 years. After some necessary nap

---

**One of the house technicians refused, saying I would electrocute anyone getting a drink...**

---

time, we were picked up at 3:30pm and taken over to the National Theater for set-up. The complex was a very modernistic one, resembling a pyramid with the top cut off, and was constructed so that the majority of the facility was underground. There were three theaters in the building; the one we played seated 1300 in one large terraced area with no balcony. The hall was completely carpeted, and the plush seats and acoustical treatment helped reduce reverb time to a manageable 1.3 seconds. House PA columns were already in place on the stage wings, but I was told that total power was only 700 watts. I demanded, and got, two larger, more powerful speaker cabinets (*Figure 3*). Each one contained 8 12-inch speakers, 8 5-inch speakers, and 8 tweeters, 4 dome-type and 4 horn-type. The two Polyvox power amps provided for these had RCA input connectors with no adapters available, not what I'd specified in my advance cable. Luis, the USIA representative present, confirmed the obvious—this information had not been relayed to the theater. I donated one of my XLR amplifier feed cables to the house technician, who took off to manufacture input cables for his amps. The a.c. power was again proving to be a problem, so once the band completed their set-up I sent them back to the hotel. They would return at 8pm, so we could have a quick sound check before the doors opened at 8:30pm.

#### IN NEED OF A GROUND

Electrical power at the National Theater was provided from outlets located on the rear wall of the stage area. The voltage here measured 220 V, but the neutral carried over 7 V and there was no equipment ground. I suggested

tying both my neutral and equipment ground tails to a huge water pipe off-stage right about 35 feet to solve both problems. One of the house technicians refused, saying I would electrocute anyone getting a drink; the house electrician was summoned to mollify his concerns and handle the hook-up. Even this took two tries; I explained what I wanted, but in Brazil black is neutral and white is hot, so what I got was a reverse phase on my output receptacle. I had the wires reversed again to achieve the normal black-hot white-neutral USA configuration. By this point, the new amplifier feed cables had arrived, so I made the connection to my snake box and soon had the PA working. The system was incredibly mid-heavy with no real highs or lows; coverage was a problem with only one cabinet per side. I used some very radical system EQ to smooth out the uneven frequency response, and chose to pan the speakers in slightly, resulting in good center and straight-on coverage, but compromising the far edges. Luis felt it was a justified decision, as only half a house was expected for tonight's performance. He was prophetic: the crowd was small, and surprisingly subdued for a Brazilian audience, due no doubt to the large turnout of diplomats. Wayne picked up on this, and wisely changed the set content in mid-show to feature more traditional Cajun waltzes and mid-tempo numbers.

Tuesday necessitated another early morning flight, although we wouldn't have to play a concert upon arrival this time. We arrived in Salvador de Bahia at 9:55am, and were met by David Kurakane, head of the local USIS office. The gear was collected and taken to the Teatro Castro Alves, where it would be stored until tomorrow's concert there. We drove the half-hour into town, checked into our hotel, and let the games begin! David was a great host, and ensured a relaxing, fun-filled day in Salvador, an area that was an intriguing mix of African and Portuguese, with some Caribbean flavoring thrown in. Near the equator, Salvador was sultry hot, with miles of beautiful beaches, bath-water warm surf, tropical sun, and gorgeous women in shades of black and cafe-au-lait. A good time was had by all, as we unwound a bit from the schedule of the last three days.

#### UNIVERSITY STRIKE

Wednesday marked the return of our

performance schedule. The evening's concert would begin at 9:30, so set-up and sound check was planned for 2pm, giving us the morning off. Before leaving the hotel to shop and sightsee, Lee and I placed a call to Rio de Janeiro to advance tomorrow's concert. The itinerary called for arrival in Rio at 10:15am, with the concert at the Federal University of Rio de Janeiro set for 1pm, a schedule that left no room for slippage. Rio CAO (Cultural Affairs Officer) Wallace Keiderling filled us in on the details and intrigues surrounding this particular date. Wally and I had worked together before in Portugal (see *db* July/August 1985), and it became clear we would need to call on his expertise and connections to make this gig happen. In reflection of Brazil's current economic and political problems, all universities were on strike, so staff assistance would be minimal; student turn-out at our concert was expected to be negligible at best. Wally was under pressure to cancel the show, but favored continuing for two reasons: the importance of the University as a site for future programming, and the fact that the show would be taped by Rio Educational Television (TVE), giving us a potential audience of 600,000. Wayne, Lee and I all concurred with his assessment, so we got down to planning details. I made sure Wally knew our PA requirements, and stressed the a.c. power and grounding situation. As the TV people would require a feed from me, I passed along the appropriate connector and impedance specifications. Vehicles and a plentiful labor force would meet us at the airport to ensure as rapid a transfer of equipment as possible, and would also assist us once at the University. With all our bases covered, we could now concentrate on today's show.

---

**At one point, almost the entire audience crammed down on the apron in front of the stage doing an elaborate line dance...**

---

We arrived at the Teatro Castro Alves around 2:10pm; it was only a short drive from the Hotel Bahia do Sol. It seated 1700 in steeply-raked theater seating. There was no balcony, but the seats were arranged into lower and



Figure 4. The band is on stage during a show and TV taping at UFRJ Blue Hall, Rio de Janeiro, Brazil.

upper tiers. Acoustics were on the dead side due to the thick rug and acoustical treatment on the walls: reverb time about 1.2 seconds, very reasonable for so large a room. A local sound company had been retained for us, so I had a substantial PA to work with. Per side, the house stacks consisted of 2 Martin bins, each with a single Snake (Brazilian speaker) 15-inch woofer, 2 low-mid enclosures with a single Snake 12-inch woofer, a 60 degree radial horn with JBL 2441 compression driver and 4 Selenium bullet tweeters. Power amps were Micrologic M-1000s, with total system power around 4000 watts. We used our own monitor set-up, with an augment from the sound company. Our normal rig serviced the band, the augment serviced Wayne. He used 2 large monitor speakers; each contained 2 Snake 12-inch woofers and 4 Motorola piezo tweeters. These were driven from the monitor send of the band's Peavey 600B, feeding a borrowed Klark-Teknik 1/3-octave equalizer and 500 watt Micrologic power amp. Electrical power came from a board off-stage left, with a 220 volt hot and a clean neutral. Again, there was no equipment ground available, so I tied to a water pipe immediately adjacent to the power board. At the mix point, I plugged my console into a stereo Klark-Teknik 1/3-octave EQ and Brooks-Siren 4-way electronic crossovers. The PA had a horrid hot spot at 3.15 kHz, and in general was overly bright, a problem I solved by properly

balancing the sections with crossover and amplifier gain controls. Sound check lasted a bit longer than anticipated, as the house right end cut out in the middle of sound check, a problem that took the PA guys 20 minutes to find and repair. We still had plenty of time to adjourn to the hotel to freshen up and eat before returning at 8:30. As the doors didn't open until 9, the guys took the opportunity to jam a bit, and I set up my tape recorder to record the show; the size of the hall and large PA meant that I could really mix "up" and get a good board tape. The audience turnout was disappointing (400 out of 1700), but they made up for it with amazing enthusiasm: they danced the entire show! At one point, almost the entire audience crammed down on the apron in front of the stage doing an elaborate line dance, which I found out later was one of Salvador's Carnival dances. After an autograph and photo session with new-found fans, we returned to the hotel to enjoy a bon-voyage party with David and to listen back to the tape, which turned out very well.

#### ON TO RIO

Thursday, March 26, began WAY too early! At 5:30am we all had our bags down in the lobby; again we containerized everything together to prevent loss in transit. We followed at 6:30am after a big breakfast, as everyone realized we might not get to eat again until after our matinee. The VASP flight to Rio took about two hours, most of which I slept

through. We arrived in Rio at 10:20am, but saw no sign of Wally until we got to baggage claim; he was waiting just outside the baggage area. Since our flight had originated outside Brazil, we were in the international area, where no outside entry was permitted. We loaded our stuff onto carts and passed them through the doors to Wally and his crew, who then loaded the trucks. Our "bucket brigade" was effective: we were at the Federal University of Rio at 11am, as it was only about a 10 minute drive from the airport. The UFRJ Blue Hall Auditorium was a small room seating 300, with hardwood surfaces and a glass wall house right (Figure 4). This gave people in the corridor outside a good view of the proceedings, but didn't help the sound at all: the room was very hot, with a reverb time of just over 2 seconds. The TV and sound people were setting up as I arrived, so I concentrated on a.c. Power came from pockets off-stage left, with European round-pin receptacles and no grounds. Wally was prepared: he'd brought a long length of copper pipe and plenty of wire. The wire was run out of a window adjacent to the auditorium, and the pipe driven into the earth, which had been wet down to decrease electrical resistance. Voltage here was 126 V, and quite stable, but I still used the transformer by switching the input tap to 120 V. The TV people weren't ready to go until 1:30pm, which gave us time to squeeze in a real sound check and figure out how to deal with the lively space. I mic'ed everything,







# Life in the Electronic Cottage

• I live in an electronic cottage. Day and night, dozens of obedient micro-processors perform countless routine tasks without the slightest whimper of protest, while the inaudible purring of radio frequencies billow up through my roof like a stream of smoke from a busy factory. A cottage industry—this is what a rapidly growing sector of the audio world has become, with a burgeoning number of audio professionals creating high quality productions in non-traditional recording environments. It may often be within the locus of domestic activity—the home or apartment, but just as often an electronic cottage is ensconced in a city loft or a country barn. It is not the location which defines an electronic cottage, but the power of the concept.

A powerful concept it is, indeed. In 1980, when Alvin Toffler (in his futuristic classic, *The Third Wave*) first presented the term, “electronic cottage,” he was presaging the effects of computer-centered living on society. It is quite interesting to see how much of his prophecy has now become a part of our reality; while Toffler made only scant reference to the particulars of the audio field, there is probably no field in which microprocessor control has had a greater impact.

Sure, there were lots of computers around in 1980, but when it came to audio applications, the majority of systems were installed in academia or elite recording studios. Then came MIDI, and everything began to change. Only a pipe dream in the minds of two men, it was not even proposed to their peers until 1981 and made its public debut in 1983. We stand now, only five years later at a place where virtually any piece of audio equipment—not only musical instruments, but recording consoles, tape transports and outboard signal processors—can communicate with each other and be controlled by

computer through a universal interface.

The upshot is a quiet revolution that is transforming the entire economy of the audio industry. Some of Toffler’s predictions which seemed a little starry-eyed in 1980 seem positively epitomized in 1988. For example, he spoke of a resurgence in the entrepreneurial spirit that would occur as “the means of production,” the computer, found its place in the hands of individuals rather than large corporate entities.

Everyone knows how true this is of recording studio enterprises today. For every major state-of-the-art facility in existence, there are perhaps hundreds of smaller self-contained electronic cottages, many of which are turning out quite formidable results. Both classes of facilities have two things in common, which tends to make them quite compatible: MIDI and computers. While some electronic cottages have generated excellent broadcast quality productions, many also serve as cost-effective pre-production facilities. Similar to the paradigm established in the video industry, we still have “on-line” recording studios where no expense is spared and any gadget known to man is always available, but we also have the extreme proliferation of “off-line” suites, where many production decisions can be implemented at relatively low cost.

The rise of the off-line audio facility reminds us of another Toffler theorem: the advent of the computer-centered electronic cottage would bring about a decentralization of power. Only a few years ago, the notion that one could generate a master recording or a movie soundtrack in anything other than a 24-track recording studio would have been greeted with a guffaw. Today, of course, we know differently.

For a variety of reasons, a lot of broadcast quality is now being generated in very average electronic cottage facilities. No doubt, the quality of lower-end audio equipment has improved, but there is more to it than this. New production techniques have evolved around a computer, allowing the preservation of “sound-as-data” for a much longer period of time before going to tape. Also a factor: the salad days of opulent recording budgets are gone, perhaps forever. Economic considerations have forced producers to be more cost-effective and the electronic cottage is in a position to supply this need. All of the above only underlines Toffler’s notion. Decentralization has occurred and continues to occur as the power to make master quality output shifts over to the electronic cottage facility.

One other concept, only briefly mentioned by Toffler is the “workstation.” Today, many large on-line studios are installing one or more smaller off-line rooms, whose equipment package is designed to be very much like the electronic cottage facility. This, of course, is to ensure that those producers who choose to start a project at home can complete it at the larger facility. Thus, we have the intention (as yet not entirely possible) of putting together something like a “universal workstation,” with great system compatibility, whereby on-line and off-line studios can work in tandem to great mutual benefit.

The fact that people are even tussling with these issues confirms the fact that the electronic cottage will be a major force in the world of audio as we peer into the 1990s. Access to reasonably-priced technology has spawned a very real populist movement within the recording industry. Many will take the opportunity to furnish an electronic cottage replete with computer-control-

led instruments, outboard signal processors, synchronized multi-track, console automation and digital mix-down—all without having to go into unmanageable debt.

No doubt, this new-found ability to do large-scale production in a small-scale studio will not only inspire entrepreneurship, but be a great boon to the creative spirit as well. What the electronic cottage may lack in terms of absolute signal processing power (relative to the on-line facility), it seems to compensate for in sheer laid-back atmosphere. As the saying goes, "Time is money!", and so, the corollary can be written: "One who has time to tweak the sounds until they sit just right is rich indeed!"

Now, before I raise the banner proclaiming 1988 the beginning of a latter-day Renaissance, let me first issue one proviso: A Renaissance is sustained by people—not technology. Although printing presses or computers are the engines of economic and creative revival, it is the Renaissance *person* who provides the fuel. With regard to the electronic cottage, this all pre-sup-

poses a well-informed owner/operator whose knowledge is thorough and diversified. Anything less than excellence in engineering will simply relegate your facility back to the Dark Ages, when small studios rarely rose above mediocrity.

Getting successful end-product from the electronic cottage requires much more than amassing equipment, pulling it out of the box and plugging it in. That kind of raw, creative optimism is good, but it can only take one so far. There is no magic bullet, no simple-minded substitute for knowledge. Sooner or later, the electronic "cottageer" will need some heavy duty advice. And that is where **db Magazine** comes in.

**db** is committed to presenting you with the insights you need to operate an absolutely smokin' electronic cottage! We realize that you are a unique constituency with special needs. You have a small studio, but you want it to be professional in every way. You want to do all that is possible to maximize your studio's signal-to-noise ratio, to set up an efficient patch bay, to build a

sonically accurate mixing environment, establish a unified electrical ground—essentially, the "nuts and bolts" agenda of the pro studio. But you need to do it all simply, efficiently and within your budget.

Likewise, you would like to hear about some innovative techniques in signal processing—ways to get an expensive sound from moderately-priced gear, and also to have other engineers and producers share with you their fondest studio techniques. Of course you need to keep on top of new computer applications in the electronic cottage, and are probably equally concerned about how best to market your services.

In coming issues, **db** will be addressing these and many more of your needs by bringing you information from the most appropriate sources: those who are traveling the same highway you are, but just might be a few miles ahead—a little bit closer to that ultimate electronic cottage.

Stay tuned!



## Copies of articles from this publication are now available from the UMI Article Clearinghouse.

For more information about the Clearinghouse, please fill out and mail back the coupon below.

**UMI** Article  
Clearinghouse

Yes! I would like to know more about UMI Article Clearinghouse. I am interested in electronic ordering through the following system(s):

- DIALOG/Dialorder       ITT Dialcom  
 OnTyme                       OCLC ILL Subsystem  
 Other (please specify) \_\_\_\_\_  
 I am interested in sending my order by mail.  
 Please send me your current catalog and user instructions for the system(s) I checked above.

Name \_\_\_\_\_

Title \_\_\_\_\_

Institution/Company \_\_\_\_\_

Department \_\_\_\_\_

Address \_\_\_\_\_

City \_\_\_\_\_ State \_\_\_\_\_ Zip \_\_\_\_\_

Phone (\_\_\_\_\_) \_\_\_\_\_

Mail to: University Microfilms International  
300 North Zeeb Road, Box 91 Ann Arbor, MI 48106

# The db Magazine Buyer's Guide

## REEL TO REEL TAPE RECORDERS

### **FOSTEX** – See our ad on Cover III

E-16 is a synchronizer ready, 16-track tape machine with built-in 2-position autolocator, servo control of reels, spot erase, real-time counter, 15 in./sec. tape speed, 10.5 in. reels, and Dolby C noise reduction. Weight is 78 lbs.

Price: \$7,995.00

E-8 is an 8-track version of the E-16.

Price: \$4,495.00

E-2 is a 2-track recorder with center track for SMPTE time code. It has built-in 2-position autolocator, servo controls of reels in the edit mode, spot erase, and balanced inputs and outputs.

Price: 3,750.00

E-22 is a 2-track recorder with center track for time code. It has built-in 2-position autolocator, servo controls of reels in the edit mode, spot erase, automatic programmable punch-in/out, and balanced inputs and outputs.

Price: \$3,995.00

M-80 is a synchronizer ready 8-track recorder. It utilizes 0.25 in. tape on 7 in. reels, and has a frequency response of 40-18 kHz at 15 in./sec. Dimensions are 14 x 13.5 x 6.75. Weight is 29 lbs.

Price: \$2,595.00

M-20 is a 2-track recorder with center track for time code. It can be used with all synchronizers and most video editors. Tape speed is 15 and 7.5 in./sec. Dimensions are 14 x 13.5 x 8.5. Weight is 29 lbs.

Price: 1,550.00

### **MITSUBISHI PRO AUDIO GROUP**

X-86 features 2 PCM audio channels, 2 cue channels, 1 time code channel, 1 aux digital channel, 0.25-inch tape format, 14-inch reel capability. Overall frequency response is 20-20 kHz +0.5 dB, -1 dB. Dynamic range is greater than 90 dB. Distortion is less than 0.05 percent, 50-20 kHz.

Price: \$25,900.00

X-850 features 32 PCM audio channels, 2 cue channels, 1 time code channel, 2 aux digital channels, 1-inch tape, 14-inch reel capability. Frequency response is 20-20 kHz +0.5 dB, -1 dB. Dynamic range is greater than 90 dB. Distortion is less than 0.05 percent, 50-20 kHz.

Price: \$194,900.00

X-400 offers 16 PCM audio channels, 2 cue audio channels, 1 time code channel, 1 aux digital channel, 0.5-inch tape, 14-inch reel capability. Frequency response is 20-20 kHz +0.5 dB, -1 dB. Dynamic range is greater than 90 dB. Distortion is less than 0.05 percent, 50-20 kHz. The X-400 is also available with 8 PCM audio channels. All other specifications are identical.

### **OTARI CORPORATION** – See our ad on Cover II

DTR-900-32 is a 1-inch format, 32-channel digital recorder with 14-inch reel size, 4 heads, 0 wow and flutter. Frequency response is 20-20 kHz +0.5 dB -1 dB. Other features include a 9600 Hz PLL (phase-locked-loop) capstan motor, 2 servo 0.5hp DC reel motors. Dimensions are 46.5 x 34.6 x 20.1.

Price: \$189,000.00

MTR-10CT is a 0.25-inch format 2-channel recorder with center-track time code. Features include 4 heads, DC servo-controlled, high torque reel motors. Wow and flutter is 0.04 percent. Frequency response is 42-29 kHz (30 in./sec.). S/N is 74 dB at 30 in./sec. Dimensions are 46.1 x 25 x 26.

Price: \$12,095.00

MTR-100A is a 2-inch format 24-track recorder with automatic alignment, 14-inch maximum reel size, quartz PLL DC brush-type direct drive capstan motor. Other features include DC brush-type bi-directional reel motor. Frequency response is 50-25 kHz  $\pm$  2 dB at 30 in./sec. Input impedance is more than 10k ohms (20-20 kHz). Dimensions are 43.7 x 30.35 x 25.98.

Price: \$59,950.00

MX-55 is a 2-channel, 0.25-inch format recorder with one DC servo-controlled capstan, two induction reel motors, 4 heads and 10.5 in. maximum reel size. Wow and flutter is less than  $\pm 0.06$  percent at 15 in./sec. Frequency response is 30-22 kHz  $\pm 2$  dB at 15 in./sec. Mic input impedance is 10k ohms. Unweighted S/N is 69 dB at 1040 nWb/m. Dimensions are 19.21 x 17.32 x 8.74.

Price: \$3,895.00

MX-70 offers 1-inch 8-track configuration, 8 pre-wired for 16 and 16-track. DC servo reel motors and brushless DC capstan motor are crystal referenced. Features include 3 heads, 10.5-inch maximum reel size, wow and flutter less than 0.04 percent, frequency response at +2 dB/-3 dB is 50-22 kHz. Unweighted S/N is 70 dB at 3 percent third harmonic distortion. Dimensions are 40.2 x 25.2 x 24.1.

Price: \$17,200.00 (8-track)

\$21,650.00 (16-track)

MX-80 comes in 2-inch 24 and 32-track models. Features include 10.5-inch maximum reel size, 9600 Hz PLL capstan motor, microprocessor-controlled, 2 servo 0.33hp DC reel motors, 3 heads, S/N (32-track) greater than 67 dB at 30 in./sec. Frequency response at 30 in./sec. is 60-22 kHz,  $\pm 2$  dB. Dimensions are 38.3 x 25.5 x 24.6.

Price: \$39,150.00 (32-track)

\$33,850.00 (24-track)

MK-III-8 is a 0.5-inch format 8-channel recorder with a 10.5-inch reel size, DC servo-controlled capstan motor, two induction reel motors, 3 heads, and 0.04 percent wow and flutter at 15 in./sec. Frequency response is 40-22 kHz,  $\pm 2$  dB. Dimensions are 17.3 x 21.3 x 26.6.

Price: \$5,495.00

MTR-90-II is available in 1-inch 8-channel, 2-inch 16-channel, 2-inch 16 pre-wired for 24 channels, and 2-inch 24-channel. Features include 3 heads, 14-inch reel size, 9600 Hz PLL capstan motor, 2 servo .5hp DC reel motors. Wow and flutter at 30 in./sec. is less than 0.04 percent. Frequency response is 45-29 kHz at 250 nWb/m at 30 in./sec. Dimensions are 42.63 x 30.38 x 24.5.

Price: \$52,950.00 (24-track)

### **SONY PROFESSIONAL AUDIO** – See our ad on page 14

APR-5002 NAB 0.25-inch analog recorder/reproducer features micro processor controlled audio alignment/tape servo and 3 DC servo motors with ceramic capstan shaft. Alignment parameters are stored in non-volatile memory with three alignments per speed and three speed operation (nine alignments per head stack). Flutter at 30 in./sec. is less than 0.025 (DIN 45507). Overall frequency response is 20-20 kHz (250 nWb/m). Other features include automatic recall of proper alignment set via encoding switch in headstack, overhead meters with monitor. Dimensions are 19.88 x 19 x 16.25.

Price: \$7,875.00

APR-5003 NAB .25-inch center track time code recorder/reproducer features internal synchronizer with offset and exclusive bit hump capabilities, internal time code generator/reader and serial control capabilities. All APR-5000 series recorders have a maximum reel size of 12-inches. All weights and dimensions are listed in the APR-5002. APR-5003 specifications are the same as APR-5002.

Price: \$9,975.00

APR-5002W NAB 2-channel recorder/reproducer features wide amorphous heads which provide superior sonic performance over standard 0.25-inch NAB heads. Greatly extended life over standard permalloy heads. As per all APR-5000 series microprocessor controlled transport and audio alignments. At 30 in./sec. frequency response is 37-25 kHz +0.75/-3 dB. At 15 in./sec. frequency response is 22-24 kHz +0.75/-2 dB. At 7.5 in./sec. frequency response is 15-33 kHz +0.75/-2 dB.

Price: \$8,875.00

APR-5002H is a 3 speed analog recorder/reproducer. Main features and options as per APR-5002 and APR-5002D. The APR-5002H incorporates half inch wide profile record and reproduce heads. This recorder is designed as a master analog recorder. S/N is referenced at 250 nWb/m and is 62 dB at 30 in./sec., 59 dB at 15 in./sec., and 59 dB at 7.5 in./sec. Weights and dimensions as per all APR-5000 series.

Price: \$8,375.00

APR-5002D is an analog, 3 speed recorder/reproducer. Main features as per APR-5002 with DIN standard heads. As with all APR-5000 series recorders: Overhead bridge metering is standard, headphone jack, optional roll around stand (SU-14), optional edit platform MB-5000. Weights, dimensions and specifications as per APR-5002.

Price: \$7,875.00

## STUDER REVOX

A820-24 multi-track recorder features automatic and simultaneous audio alignment for all channels (with alignment parameters stored in non-volatile memory for 2 tape types). The series features a menu-programmable transport offering a choice of over 40 assignable functions, sophisticated servo control systems allowing extremely quick acceleration and deceleration, and optionally either Dolby SR or Telcom C4 noise reduction systems. Wow and flutter is 0.04 percent at 30 in./sec. Frequency response is 50-20 kHz  $\pm 2$  dB. High level input imp. is equal to or greater than 10k ohms balanced. Unweighted S/N, 0VU = 512 nW/m is 64 dB at 30 in./sec. Dimensions are 30 x 56 x 28. Weight is 5861 lbs.

Price: \$69,000.00 (A820-24 w/o noise reduction)

\$34,500.00 (A820-8)

A820 2/2 VUK master recorder features the same processor control for audio and tape transport as the A820-24, and the same transport and drive assembly capability as the 24-track version for 2-inch tape and 14-inch reels. Wow and flutter at 30 in./sec. is 0.04 percent. Frequency response is 40-22 kHz  $\pm 2$  dB. High level input imp. is equal to or greater than 10k ohms balanced. Unweighted S/N, 0VU = 512 nWb/m is 64 dB at 30 in./sec. Dimensions are 27.5 x 27.5 x 51. Weight is 200 lbs.

Price: \$13,750.00

D820X DASH format 2-channel digital audio recorder offers twin recording at 15 in./sec. 12 tracks in symmetrical geometry are recorded on 0.25-in. tape. 8 tracks are reserved for digital audio, 1 for time code, 1 for reference data and 2 for digital cueing. Other features include DC driven spooling and capstan motors. Frequency response is 10-23 kHz  $\pm 0.4$  dB. Input imp. is 20k ohms. THD + N full scale is greater than 85 dB. Dimensions are 26 x 27.5 x 42.

Price: \$29,950.00

A810 professional recorder is designed for general as well as specialized post-production applications. It uses different head combinations on its 4-head, plug-in headblock for recording, playback, machine synchronization with Neopilot, FM Pilot and SMPTE time code. Other features include digital audio alignment and storage. Rack-mount or console models available, console either with or without overbridge. Wow and flutter is 0.04 percent at 30 in./sec. Frequency response is 40-22 kHz  $\pm 2$  dB. High level input imp. (balanced, with transformer) is equal to or greater than 10k ohms. Mic input imp. is  $> 1.2k$  ohms. Unweighted S/N, 0VU = 250nW/m via tape is 55 dB. Time code channel crosstalk attenuation 90 dB. Utilizes 11.5 in. reels. Dimensions are 22.13 x 25.13 x 45.5. Weight is 67 lbs.

Price: \$10,750.00

A812 2/2 time code (option) VUK is a compact recorder suited for broadcast applications. Featuring the same processor control for audio and tape transport as the A820, the A812 is available with or without overbridge, and in two basic console versions. Wow and flutter is 0.04 percent at 30 in./sec. Frequency response is 40-22 kHz  $\pm 2$  dB. Input imp. (balanced, with transformer) is equal to or greater than 10k ohms. Unweighted S/N, 0VU = 512nW/m is 70 dB. Utilizes 12.5-inch reels. Dimensions are 25 x 26 x 45.5. Weight is 94.5 lbs.

Price: \$11,750.00

A807 2/2 VUK is especially suited for broadcast, post-production and/or studio environments. Features include tape shuttle wheel, reverse play, right hand edit, tape dump, varispeed, multi-function tape time and autolocator with programmable "soft keys," digital setting of audio alignment parameters for 3 tape speeds and 2 tape types, phantom powered mic inputs on portable version, RS 232 port, optional quarter-track playback head, DC servo Hall effect capstan motor, AC servo reel motors, Dolby HX Pro standard. Available in portable and rack-mount configurations, including a 4-channel .5-inch version. Wow and flutter is 0.05 percent at 15 in./sec. Freq. response is 30-20 kHz  $\pm 2$  dB. Utilizes 11.1-inch reels. Weight is 67 lbs.

Price: \$7,595.00 (console version)

C270 2-track 0.25-inch analog tape recorder features microprocessor based control logic, servo controlled constant tape tension on supply and take-up, one-hand editing under full servo control. DC Hall effect servo capstan motor and AC servo reel motors. Dolby HX Pro standard, RS 232 standard. Varispeed, monitor speaker, 3-speed, plug-in record and reproduce equalizers. Rack mounts included. Wow and flutter is 0.05 percent at 15 in./sec. Freq. response is 30-22 kHz  $\pm 2$  dB. High level input imp.  $> 5k$  ohms. Mic input imp.  $> 1.2k$  ohms. Unweighted S/N, 0VU = 250 nWb/m via tape is 54 dB. Utilizes 10.5-inch reels. Dimensions are 19 x 17.5 x 8. Weight is 51 lbs.  
Price: \$3,695.00

PR99 is a 2-track production recorder with professional features that include real-time counter that reads both plus and minus hours, minutes and seconds, zero locate to return tape to zero counter location, a true auto locator for precise and automatic search-and-cue to any preselected address point, auto repeat for continuous replay of any length tape segment, built-in front panel varispeed, and self-sync. Wow and flutter 0.06 percent at 15 in./sec. Freq. response is 30-22 kHz  $+2/-3$  dB. High level inputs balanced  $> 5k$  ohms. Mic input imp. (balanced, with transformer) is equal to or greater than 1.2k ohms. Unweighted S/N, 0VU = 250nW/m via tape is 55 dB. Uses 10.5-inch reels. Rack mounts included. Floor console and monitor panel available. Dimensions are 19 x 13.5 x 8. Weight is 40.75 lbs.  
Price: \$2,799.00

### **TASCAM PROFESSIONAL DIVISION (TEAC CORPORATION OF AMERICA)** – See our ad on Cover IV

32 is a two channel, 2-track recorder/reproducer utilizing 0.25 in. tape format on 10.5 in. maximum reel size. It is a 3-head, 2-slotless DC motor machine. The capstan system is a frequency generator DC servo motor with a precision machined aluminum shaft. Tape speeds are 15 and 7.5 in./sec. selectable with wow and flutter measured at 0.05 and 0.09, both NAB weighted. Overall frequency response is 40-20 kHz (15 in./sec.) at  $\pm 3$  dB at 0VU, and 40-16 kHz (7.5 in./sec.) at  $\pm 2$  dB at 0VU. Line input imp. is 10k ohms balanced, 50k ohms unbalanced. S/N measures 60 dB and 58 dB, both unweighted from 0-100 kHz. Dimensions are 19.88 x 17 x 12.44. Weight is 44.13 lbs.

Price: \$1,749.00

38 is an 8-channel, 8-track recorder/reproducer utilizing .5-in. tape format on 10.5-in. maximum reel size. It has 3 heads and 2-slotless DC motors. The capstan system is a frequency generator DC servo motor with a precision machined aluminum shaft. Tape speed is 15 in./sec. with wow and flutter measured at 0.05 NAB weighted. Overall frequency response is 40-20 kHz measured  $\pm 3$  dB at 0VU. Line input imp. is 50k ohms unbalanced. S/N measures 68 dB unweighted from 0-100 kHz. Dimensions are 19.88 x 17 x 12.44. Weight is 59.56 lbs.

Price: \$2,999.00

42B is a 2-channel, 2-track recorder/reproducer utilizing 0.25-in. tape format on 10.5-in. maximum reel size. It is a 3-head, 2-slotless DC motor machine. The capstan system is phase-locked-loop DC direct drive motor with a ceramic shaft. Tape speeds are 15 and 7.5 in./sec. selectable with wow and flutter measured at 0.05 and 0.06, both NAB weighted. Overall frequency response is 40-20 kHz (15 in./sec.) at  $\pm 3$  dB at 0VU and 40-16 kHz (7.5 in./sec.) at  $\pm 2$  dB at 0VU. Line input imp. is 10k ohms balanced, 50k ohms unbalanced. S/N measures 62 dB and 60 dB, both unweighted from 0-100 kHz. Dimensions are 19.88 x 17 x 12.44. Weight is 70.56 lbs.

Price: \$2,999.00

480B is a 8-channel, 8-track recorder/reproducer utilizing 0.5-in. tape format on 10.5-in. maximum reel size. It is a 3-head, 2-slotless DC motor machine. The capstan system is a phase-locked-loop DC direct drive motor with a ceramic shaft. Tape speed is 15 in./sec. with wow and flutter measured at 0.05 NAB weighted. Overall frequency response is 40-20 kHz, measured  $\pm 3$  dB at 0VU. Line input imp. is 10k ohms balanced, 50k ohms unbalanced. S/N measures 69 dB unweighted form 0-100 kHz. Dimensions are 19.88 x 17 x 12.44. Weight is 81.38 lbs.

Price: \$4,999.00

388 "Studio 8" is an 8-channel, 8-track recorder/reproducer utilizing 0.25-in. tape format on 7-in. maximum reel size. It is a 2-head machine with 2-DC servo reel motors. The capstan system is a frequency generator servo DC motor. Tape speed is 7.5 in./sec. with wow and flutter measured at 0.05 percent NAB weighted. Overall frequency response is 30-16 kHz at  $\pm 3$  dB at 0VU. Line input imp. is 50k ohms unbalanced; microphone input imp. is 2.4k ohms balanced. S/N measures 90 dB unweighted from 20-20 kHz. Other features include an 8 x 8 x 2 mixer with 8-track monitoring, 3-band parametric EQ and effect and aux sends on each channel. Dimensions are 8.69 x 32.94 x 25.25. Weight is 83.63 lbs.

Price: \$3,999.00

MS-16 is a 16-channel, 16-track recorder/reproducer utilizing 1-in. tape format on 10.5-in. maximum reel size. It is a 3-head, 2-slotless DC motor machine. The capstan system is a phase-locked-loop DC direct drive motor with a ceramic shaft. Tape speed is 15 in./sec. (30 in./sec. on request) with wow and flutter measured at 0.04 percent NAB weighted. Overall frequency response is 40-22 kHz, measured  $\pm 3$  dB at 0VU. Line input imp. is 10k ohms balanced, 50k ohms unbalanced. S/N measures 62 dB unweighted form 0-100 kHz. Dimensions are 18.062 x 19 x 12.19. Weight is 83.75 lbs. (transport unit); 7.63 x 19 x 12.63, weight is 36.38 lbs. (amplifier unit).

Price: \$8,999.00

ATR-60/2T is a 2-channel, 2-track recorder/reproducer with an additional IEC standard center track for timecode. Utilizing 0.25-in. tape format on 10.5-in. maximum reel size, it is a 3-head, 2-slotless motor machine. The capstan system is a phase-locked-loop DC direct drive motor with a ceramic shaft. Tape speeds are 15 or 7.5 in./sec., with wow and flutter measured at 0.05 percent RMS NAB weighted. Overall frequency response is 40-22 kHz (15 in./sec.) at  $\pm 2$  dB at 0VU, and 40-16 kHz (7.5 in./sec.) at  $\pm 2$  dB at 0VU. Line input imp. is 10k ohms balanced. S/N measures 67 dB for both speeds unweighted form 0-100 kHz. Dimensions are 18.13 x 19 x 12.19. Weight is 83.75 lbs. (transport unit); 4.13 x 19 x 10.56, weight is 16.56 lbs. (amplifier unit).

Price: \$6,999.00

ATR-80/24 is a 24 channel, 24-track recorder/reproducer utilizing 2-in. tape format on 14-in. maximum reel size. It is a 3-head machine and features noiseless, gap-less and seamless punch-in/punch-out with 2-Rare Earth DC reel motors. The capstan system is a phase-locked-loop DC direct drive motor with a ceramic shaft. Tape speeds are 30 and 15 in./sec. selectable with wow and flutter measured at  $\pm 0.05$  percent peak (30 in./sec.) and  $\pm 0.06$  percent peak (15 in./sec.), both DIN 45507 weighted. Overall frequency response is 45-25 kHz (30 in./sec.)  $\pm 2$  dB and 35-20 kHz (15 in./sec.)  $\pm 2$  dB. Line input imp. is 10k ohms or 600 ohms balanced (switchable). S/N measures 67 dB (30 in./sec., unweighted AES) and 65 dB (15 in./sec., unweighted NAB). Dimensions are 38.94 x 30.13 x 29.63.

Price: \$39,999.00

## UHER OF AMERICA

1200 Report Synchro is a portable full track monaural recorder with pilot track. Features include 3 heads, 5-inch reel, 1 channel, belt drive, 1 VU meter, 2 mixable mic inputs, switchable ALC selectable record/playback equalizer. Machine operates at 7.5 in./sec. Freq. response is 40-16 kHz. Wow and flutter 0.15 percent. S/N is 52 dB. Mic inputs are 200 ohms (balanced). Dimensions are 11 x 3.5 x 9. Weight is 8 lbs.

Price: \$5,049.00

6000 Report Universal is a portable 2-track monaural open reel machine. Features include 4 speeds (3.75, 1.875, 0.937 and 0.468 in./sec.), 3 heads, 5-inch reel, 1 channel, solenoid controlled functions, belt drive, 1 VU meter, built-in voice activation system, memory pulse facility, fully remote controlled. Freq. response is 20-22 kHz. Wow and flutter 0.2 percent. S/N is 62 dB. Dimensions are 11 x 3.5 x 9. Weight is 8 lbs.

Price: \$2,150.00

4000 Report Monitor AV is a portable open reel, 2-track monaural, 4 speed (0.937, 1.875, 3.75, and 7.5 in./sec.), 3 head, 5-inch reel machine. Features include 1 channel, belt drive, 1 VU meter. Freq. response is 20-25 kHz. Wow and flutter 0.2 percent. S/N is 64 dB. Mic inputs are 200 ohms with LED function indicators and switchable ALC. Dimensions are 11 x 3.5 x 9. Weight is 8 lbs.

Price: \$1,665.00

4200 Report Monitor is a portable open reel, 2-track. Features include 4 speeds (.937, 1.875, 3.75, and 7.5 in./sec.), 3 heads, 5-inch reels, 2 channels, belt drive, 2 VU meters. Freq. response is 20-25 kHz. Wow and flutter 0.2 percent. S/N is 64 dB. Mic inputs is 200 ohms (balanced). Dimensions are 11 x 3.5 x 9. Weight is 8 lbs.

Price: \$1,779.00

4400 Report Monitor is a portable open reel, 4-track stereo machine. Features include 4 speeds (0.937, 1.875, 3.75 and 7.5 in./sec.), 3 heads, 5-inch reels, 2 channels, belt drive, 2 VU meters. Freq. response is 20-25 kHz. Wow and flutter 0.2 percent. S/N is 62 dB. Mic inputs are 200 ohms (balanced), LED indicators, switchable ALC. Dimensions are 11 x 3.5 x 9. Weight is 8 lbs.

Price: \$1,779.00

## CASSETTE TAPE RECORDERS

### AKAI

MG1214 is a 14-track, 12-channel mixer. There are 14 tracks (12 audio, 1 sync, 1 control). Features offered are 0.5-inch tape format (AKAI original cassette), FG servo DC capstan motor, coreless DC reel motors, DC loading motor, 3 heads, 7.48 in./sec. and 3.74 in./sec. Flutter at 7.48 in./sec. is 0.03 percent. Freq. response at 7.48 in./sec. is 50-20 kHz. S/N is 94 dB. Other features include dbx Type 1 noise reduction, a programmable memory for autolocation, auto punch recording. The mixer section has 12 mic/line inputs, 2 effects sends, 2 stereo returns, bus A & B out, monitor out, master outs, sync out. Dimensions are 8.07 x 33.7 x 29.61. Weight is 92.4 lbs.

Price: \$8,999.95

MG14D is a 14-track recorder featuring 12 audio tracks, 1 sync track, and 1 control track. Tape format is 0.5-inch AKAI original cassette. Other features include FG servo DC capstan motor, coreless DC reel motors, DC loading motor, 3 heads, 7.48 and 3.74 in./sec. speeds. Flutter at 7.48 in./sec. is 0.03 percent. Freq. response at high speed is 50-20 kHz. S/N is 94 dB. Noise reduction is dbx Type 1. There are 12 unbalanced RCA inputs and 12 balanced XLR inputs, synchronizer jack. Dimensions are 8.82 x 19 x 16.93. Weight is 50.6 lbs.

Price: \$6,799.95

\$6,999.95 (with autolocator)

MG614 is a 6-channel, 4-track mixer. Tape format is C-cassette, CrO<sub>2</sub>. Features include 2 heads, FG servo direct drive capstan motor, DC reel motor, DC cam drive motor, 3.74 and 1.87 in./sec., pitch control  $\pm 10$  percent, 0.04 percent flutter, 30-20 kHz freq. response at higher speed, 60 dB S/N, 70 dB crosstalk at 1 kHz with dbx on. Mixer section has 6 mic/line inputs (0.25-inch phone and XLR), effects sends, effects returns, parametric EQ. Dimensions are 6.18 x 18.5 x 21.89. Weight is 31.9 lbs.

Price: \$1,699.95

GX912 is a stereo deck utilizing 3 heads, FG servo DD capstan motor, DC reel motor, DC mechanism drive motor. Flutter is 0.025 percent. Freq. response is 20-20 kHz (chrome), 20-21 kHz (metal). S/N is 60 dB (metal). Line input is 70mV/47k ohms. Line output is -10 dBV 1k ohms. Dimensions are 4.13 x 19 x 14.65. Weight is 15.4 lbs.

Price: \$799.95

### AMR (AUDIO MEDIA RESEARCH)

MCR-4 is a 4-channel recorder. The FG servo controlled capstan motor is front panel adjustable  $\pm 12$  percent. Peak ready LED meters indicate record and playback levels. Inputs and outputs are normally -10 dBV but inputs ranging from -10 dBV to +4 dBu can be accommodated. Unweighted S/N is 55 dB (68 dB in Dolby C) with a freq. response of 40-14 kHz. A pull switch on the headphone control allows monitoring of 2-track recordings. Dimensions are 5.25 x 16.88 x 11.25. Weight is 16.5 lbs.

Price: 699.50

MCR-4/A is a dual speed 4-channel recorder with servo controlled capstan motor. Speed is switchable between 1.875 and 3.75 in./sec. with  $\pm 12$  percent front panel pitch adjustment. Peak reading LED meters indicate record/playback levels. Inputs and outputs are -10 dBV but inputs between -10 dBV and +4 dBu are accepted. Unweighted S/N at 3.75 in./sec. is 58 dB (71 dB in Dolby C) with a  $\pm 1/3$  dB freq. response of 40-14 kHz. Dimensions are 5.25 x 16.88 x 11.25. Weight is 16.5 lbs.

Price: \$999.50

MCR-4/S is a synchronization ready 4-channel recorder. With servo capstan motor, it is switchable between 1.875 and 3.75 in./sec. with  $\pm 12$  percent front panel pitch adjustment. Peak reading LED meters indicate record/playback levels. Outputs are nominally -10 dBV, while inputs from -10 dBV to +4 dBu are accepted. Unweighted S/N at 3.75 in./sec. is 58 dB (71 in Dolby C) with a  $\pm 1/3$  dB freq. response of 40-14 kHz. Dimensions are 5.25 x 16.88 x 11.25 with 19-inch rack-mount kits optional. Weight is 16.5 lbs.

Price: 1,099.50

### NAKAMICHI

MR-1 professional deck has three discrete heads, dual capstan, balanced (+4 dB) operating levels, rack-mountable, Dolby B and C, and a frequency response of 20-20 kHz,  $\pm 3$  dB. S/N is 70 dB. Wow and flutter is less than 0.048 percent.

Price: \$995.00



MR-2 professional deck is rack-mountable and has variable output levels of -10 to +4, 0.25-inch phone jacks, Dolby B and C, and a frequency response of 20-20 kHz,  $\pm 3$  dB. S/N is 68 dB. Other features include microprocessor controlled transport, and less than 0.11 percent wow and flutter.

Price: \$595.00

## STUDER REVOX

Studer A721 features a 4-motor, dual capstan, die cast transport and headblock with Dolby B, C and Dolby HX Pro. Audio electronics are automatically self-aligned for level, bias and EQ. Six memories to store alignments of 3 tape types. Other features are a real time counter, locator function with address memories, calibrated and uncalibrated input and output levels, and a backlit LCD multi-function display. Rack mounts included. Wow and flutter is 0.1 percent. Frequency response is 20-20 kHz (tape type II)  $\pm 3$  dB. S/N is 72 dB with Dolby C, metal tape. Dimensions are suitable for rack mounting. Weight is 23.1 lbs.

Price: \$2,595.00

## TASCAM PROFESSIONAL DIVISION (TEAC CORPORATION OF AMERICA) – See our ad on Cover IV

112 is a 2-channel, 2-track recorder/reproducer. It is a 2-head, 3 (1 DC servo capstan, 1 DC reel, 1 DC ancillary) motor machine. Tape speed is 1.875 in./sec. with wow and flutter measured at 0.04 percent, NAB weighted. Frequency response is 25-19 kHz  $\pm 3$  dB (metal tape), Dolby out. Line input imp. is 20k ohms unbalanced. S/N is 78 dB (Dolby C in). Dimensions are 5.25 x 19 x 11.69. Weight is 13.5 lbs.

Price: \$679.00

122MK II is a 2-channel, 2-track mastering deck. It is a 2-head, 3 (1 FG servo direct drive capstan, 1 DC reel, 1 DC ancillary) motor machine. Tape speed is 1.875 in./sec. with wow and flutter measured at 0.04 percent, NAB weighted. Overall frequency response is 25-20 kHz (metal tape), Dolby out. Line imp. is 30k ohms unbalanced, 40k ohms balanced. S/N is 78 dB (Dolby C in). Dimensions are 5.25 x 19 x 11.69. Weight is 17 lbs.

Price: \$1,099.00

Porta O5 Ministudio is a 4-channel, 4-track recorder/mixer. It is a 2-head, 1 servo motor machine. Tape speed is 1.875 in./sec. with wow and flutter at 0.05 percent, NAB weighted. Overall frequency response is 40-12.5 kHz, dbx out. Line input imp. is 50k ohms unbalanced, 5k ohms unbalanced. S/N measures 85 dB IHF A-weighted. A 4 x 2 mixer with an effects send, tape cue and pan per channel, overall stereo EQ controls, pitch control and stereo headphone output. Dimensions are 2.4 x 14.2 x 7.2. Weight is 4.4 lbs.

Price: \$499.00

Porta One Ministudio is a 4-channel, 4-track recorder/mixer. It is a 2-head, 1 servo motor machine. Tape speed is 1.875 in./sec. with wow and flutter measured at 0.05 percent, NAB weighted. Overall frequency response is 40-12.5 kHz  $\pm 3$  dB, dbx out. Line input imp. is 50k ohms unbalanced mic/line. S/N measures 85 dB IHF A-weighted. The unit incorporates a 4 x 2 mixer with an input trim, HI and LO EQ controls, tape cue and pan per channel, overall pitch control and stereo headphone output. Dimensions are 2.75 x 13 x 9.81. Weight is 6.6 lbs.

Price: 649.00

Porta Two Ministudio is a 6-channel, 4-track recorder/mixer. It is a 2-head, 1 servo motor machine. Tape speed is 1.875 in./sec. with wow and flutter measured at 0.05 percent, NAB weighted. Overall frequency response is 40-12.5 kHz  $\pm 3$  dB, dbx out. Line input imp. is 50k ohms unbal. mic line, 5k ohms unbal. line. S/N is 85 dB IHF A-weighted. A 6 x 2 mixer is attached with an input trim, HI and LO EQ, effects send, and pan per channel, overall pitch control and stereo headphone output. Dimensions are 2.69 x 16.13 x 11.75. Weight is 7.7 lbs.

Price: \$949.00

246 Portastudio is a 6-channel, 4-track recorder/mixer. It is a 2-head, 3 motor (1 FG servo DC capstan, 1 DC reel, 1 ancillary control motor) machine. Tape speed is 1.875 or 3.75 in./sec. selectable, with wow and flutter at 0.04 percent, NAB weighted. Overall frequency response is 20-20 kHz  $\pm 1$  dB. Mic/line input imp. is 10k ohms unbal. S/N is 80 dB unweighted 20-20 kHz. It utilizes a 6 x 2 mixer with an input select switch, input trim, HI and LO EQ, 2 effects sends, and stereo pan per channel, L/R or track 1-4 bus assign switches, pitch control stereo cue/monitor system, and stereo headphone output. Dimensions are 4.81 x 19.69 x 15.81. Weight is 22.7 lbs.

Price: \$1599.00

238 Syncaset is a 8-channel, 8-track standard cassette recorder/reproducer. It is a 2-head, 3 (1 FG servo direct-drive capstan, 1 DC ancillary) motor machine. Tape speed is 3.75 in./sec. with wow and flutter at 0.04 percent WRMS, JIS/NAB weighted. Overall frequency response is 30-16 kHz  $\pm$  3 dB. Line input imp. is 30k ohms unbalanced line. S/N measures 54 dB dbx out, unweighted 20-20 kHz. Dimensions are 5.25 x 19 x 11.69 and is rack mountable. Weight is 17 lbs.

Price: \$2,295.00

DA 50 is a 2-channel, 2-track digital audio cassette recorder. It utilizes 4-DD motors (1 drum, 1 capstan, and 2 reel). Tape speed is 0.32 in./sec. with unmeasurable wow and flutter. Overall frequency response is 1-22 kHz  $\pm$ 0.5 dB. Line input imp. is balanced XLR. S/N is better than 92 dB. THD is rated at less than 0.005 percent referenced to 1 kHz. It is also rack mountable and features a full-function wired remote control unit. Dimensions are 6.25 x 17.68 x 18.06. Weight is 44 lbs.

Price: \$3,999.00

## TECHNICS

RS-B605 is a microprocessor controlled, quarter-track, 2-channel stereo recorder/reproducer. Tape speed is 1.875 in./sec. Wow and flutter is 0.06 percent. Frequency response is 30-18 kHz (metal tape), 30-17 kHz (CrO<sub>2</sub>), 30-16 kHz (normal). S/N is 92 dB (dbx in), 74 dB (Dolby C in), 66 dB (Dolby B in), 56 dB (NR out). Bias frequency is 80 kHz. The machine utilizes 2-DC servo motors and a 2-head system. Dimensions are 4.53 x 16.94 x 11.31. Weight is 9.5 lbs.

Price: \$435.00

RS-T55R is a double quick reverse deck with high speed editing. Deck A is a quarter-track, 2-channel recorder/reproducer. Deck B is a quarter-track, 2-channel reproducer. Tape speed is 1.875 in./sec. Wow and flutter is 0.07 percent. Frequency response is 20-17 kHz (metal tape), 20-16 kHz (CrO<sub>2</sub>), 20-16 kHz (normal). S/N is 92 dB (dbx in), 74 dB (Dolby C in), 66 dB (Dolby B in), 56 dB (NR out). Both decks utilize 3-DC servo motors. Dimensions are 4.53 x 16.94 x 10.78. Weight is 11.5 lbs.

Price: \$475.00

RS-T80R is a double quick reverse deck with series and parallel recording. Deck A is a quarter-track, 2-channel recorder/reproducer. Deck B is a quarter-track, 2-channel reproducer. Tape speed is 1.875 in./sec. Wow and flutter is .08 percent. Frequency response is 30-18 kHz (metal), 30-17 kHz (CrO<sub>2</sub>), 30-16 kHz (normal). S/N is 92 dB (dbx in), 75 dB (Dolby C in), 67 dB (Dolby B in), 57 dB (NR out). Both decks utilize 2-speed DC servo motors. Dimensions are 4.38 x 16.94 x 10.84. Weight is 11.7 lbs.

Price: \$690.00

RS-B905 is a dual-capstan, 3-head recorder/reproducer. Features include auto tape select with FL indicators that detects normal/CrO<sub>2</sub>/metal tape formulations and sets the bias and equalization automatically. Wow and flutter is .04 percent. Tape speed is 1.875 in./sec. Frequency response is 30-20 kHz (metal), 30-19 kHz (CrO<sub>2</sub>), 30-18 kHz (normal). Dynamic range is 110 dB at 1 kHz with dbx in. The machine utilizes a 3-head configuration in conjunction with 2-DC servo motors. Dimensions are 4.31 x 16.94 x 11.25. Weight is 11 lbs.

Price: \$780.00

## UHER OF AMERICA

CR 160AV is a portable, quarter-track 2-head recorder/reproducer. Features include 2 VU meters, Dolby B and C, switchable ALC, sync, dubbing outlet, LED function indicators, solenoid control. Frequency response is 30-16 kHz. Wow and flutter is less than 0.2 percent. S/N is 64 dB. Dimensions are 9 x 2 x 7. Weight is 7 lbs.

Price: \$999.00

CR 1600 is a portable, quarter-track recorder/reproducer. It features electronic drive control for auto-reverse operation in record or playback mode. Tape speeds are 0.937 and 1.875 in./sec. the 1600 offers 3 heads, 2 VU meters, Dolby NR, switchable ALC, solenoid control, fully remote controlled, built-in voice activated system, memory pulse facility and a record time of 6 hours. Frequency response is 20-19 kHz. Wow and flutter is less than .2 percent. S/N is 64 dB. Dimensions are 9 x 2 x 7. Weight is 7 lbs.

Price: \$1,750.00

CR 1601 Monitor is a portable 4-track monaural recorder/reproducer. It features 3 speeds (0.468, 0.937, 1.875 in./sec.), 3 heads, 2 channels, 1 VU meter, switchable ALC, solenoid control, fully remote controlled, built-in voice activation system, memory pulse facility and a record time of 8 hours. Frequency response is 20-19 kHz. Wow and flutter is less than 0.2 percent. S/N is 50 dB. Dimensions are 9 x 2 x 7. Weight is 7 lbs.

Price: \$1,799.00

## TAPE

### AGFA-GEVAERT, INC.

PEM 469 is a 1.5 mil, high output, low noise and low print-through studio mastering tape. Features include an extended dynamic range, tensilized base, excellent slitting and bias compatibility. This tape is available in 5-in., 7-in. and 10.5-in. reel, hub bulk, 10.5-in. SK reel, 14-in. reel. Formats are 0.25, 0.5, 1 and 2-in.

PEM 468 is a 1.5 mil, high output, low noise, low print-through studio mastering tape. Features include tensilized base, batch number and web position printed on back coating, and excellent slitting. 5-in., 7-in. and 10.5-in. reels, hub bulk, hub, and 10.5-in. SK reels are available. Tape widths are 0.25, 0.5, 1 and 2-in.

PEM 291 is 1 mil, high output, low noise digital mastering tape. This tape offers fewer dropouts, superior slitting and is available in 10.5-in., 12.5-in. and 14-in. reels in 0.25, 0.5 and 1-in. formats.

PEM 526 is a 1.5 mil, high output, low noise, low print-through bin mastering tape. This tape is specifically designed for bin application, high frequency and mechanical stability. Available formats are 0.25, 0.5, and 1-in. and comes in hub bulk.

Standard ferric music grade PE 619 I (C-60), PE 919 I (C-90) and premium ferric music grade PE 649 (C-60), PE 949 (C-90), PE 1249 (C-120) is bulk audio cassette tape (standard bias) that offers low noise, high output, exceptional high-end response for IEC bias I, 120 $\mu$ s equalization and is designed for high quality music recording.

PE 27 (C-60) and PE 827 (C-90) is high bias, low noise cassette tape that offers pure chromium dioxide optimized for IEC bias II 70  $\mu$ s chrome equalization and is designed for high quality music recording where strong dynamics and high frequency response are critical performance factors.

Magnetite 62 (C-60 and C-90) is designed for the high speed duplicator. Characteristics include the low end punch of an excellent bias I tape and the high end ability of a bias II tape.

R-DAT (packaged/duplicator) is designed specifically for the rotary-head digital audio tape cassette format. This tape features precision coating with pure metal pigments and a special back-coating that ensures perfect mechanical performance.

### AMPEX

Grand Master 456 studio mastering tape is an analog mastering tape available in 0.25, 0.5, 1 and 2-inch widths and 1200 to 5000-foot lengths. The base film is nominally 1.5 mil polyester with gamma ferric oxide and high conductivity carbon backcoat.

406 analog audio mastering tape is available in 0.25, 0.5, 1 and 2-inch widths, and 600 to 5000-foot lengths. Base film is 1.5 mil polyester with gamma ferric oxide and high conductivity carbon backcoat. 407 mastering tape is the same as 406 but the base film is 1 mil thick and it is available in 900 to 3600-foot lengths.

467 digital mastering tape is available in 0.25, 0.5, and 1-inch widths and 4600, 7200 and 9700-foot lengths. Base film is 1 mil polyester with a cobalt modified gamma ferric oxide and high conductivity carbon backcoat.

467 digital audio cassettes are U-matic cassettes specifically designed for digital audio PCM applications. The cassettes are available in 30, 60 and 75-minute play lengths. Base film is polyester with a thickness of 0.81, 0.75 and 0.57 mils respectively.

600 series open reel and duplicator tape has a polyester base film in 0.5, 1 and 1.5 mil thicknesses and 0.25-inch width. Reel configurations are 600 to 3600-feet and 2500 to 7200-feet for duplicator tape. It utilizes gamma ferric oxide and is non-backcoated.

615 and 616 cassette duplicator tape is a Type I tape for C-60 (615) and C-90 (616) duplication. Base film is polyester in 0.45, and 0.26 mil thicknesses, respectively and comes in 0.15-inch width. Both use ferric oxide coating, non-backcoated.

478 low print-through mastering tape is designed for recording applications where very low print-through is required. Available in 0.25 and 0.5-inch widths with plastic reels, NAB metal reels, NAB hubs and CCIR hubs.

## **BASF**

LH Extra I cassette tapes utilize high performance ferric tape and are available in C-60 and C-90.

LH Maxima I cassette tapes utilize high performance tape with enhanced low and high frequency MO values. It is available in C-60 and C-90.

Chrome Extra II cassette tapes utilize pure chrome tape with extra low and high frequency sensitivity MOL, ultra-low bias and modulation noise. It is available in C-60 and C-90 lengths.

Chrome Maxima II cassette tapes are high density formulation with enhanced low and high frequency MOL for extra dynamic range. It is available in C-60 and C-90 lengths.

Loop Master 921 open reel tape is chrome mastering tape with back-coated design for high-speed bin mastering use. Dynamic range at 3.75 in./sec. is equal to a ferric master recorded at 7.5 in./sec. It is available in 0.5 and 1-inch configurations on 2400-foot hubs.

## **TDK ELECTRONICS CORPORATION**

MA-XG (type IV) cassettes feature the new, three-layer RS-II vibration-dampening mechanism for reduced modulation noise. Super Finavinx metal formulation yields low bias noise and greater low and high frequency MOL. Available in C-90 and C-60 lengths.

MA (type IV) cassettes deliver wide dynamic range and high MOL due to TDK's metal-particle formulation. Available in C-90 and C-60 lengths.

SA-XG (type II) cassettes feature a dual-layer Super Avilyn coating for ultra-low bias noise and increased low-frequency response. RS-II three-layer cassette mechanism yields reduced modulation noise. Available in C-90 and C-60 lengths.

SA-X (type II) cassette has the same formulation as SA-XG but with dual-layer cassette mechanism. Available in C-90 and C-60 lengths.

SA (type II) cassette is ideal for most music recording applications. Universally acknowledged as the reference standard in high-bias formulations, SA is available in C-90 and C-60 lengths.

AD-X (type I) cassette utilizes Super Avilyn particles for extra recording headroom and features the laboratory standard mechanism for reliable tape handling. Available in C-90 and C-60 lengths.

AD (type I) cassettes use fine-grain magnetic particles for low noise and are ideal for improved performance in portable, car and personal stereos. Available in C-90 and C-60 lengths.

D (type I) is a highly reliable normal-bias cassette combining a general-purpose formulation with precision cassette shell mechanism. Available in C-30, C-46, C-60, C-90 and C-120 lengths.

## **3M-(SCOTCH)**

#250 audio mastering tape incorporates a 1.5 mil thick back-coated polyester backing. Delivers high output/low noise performance with the widest possible dynamic range of analog mastering tapes. Ideal for high quality music mastering.

#226 audio mastering tape has a 1.5 mil thick back-coated polyester backing. Provides high output without distortion and minimal print through. Designed for music mastering.

#227 audio tape has a 1 mil thick back-coated polyester backing. Has the same performance characteristics as #226 with a longer playing time. Ideal for quality music recording where extended recording/playing time is needed.

#275 digital audio tape utilizes a 1 mil thick back-coated polyester backing. Designed for high-quality, reliable performance on stationary head digital recorders.

#806 audio mastering tape has a 1.5 mil thick back-coated polyester backing. Developed to give good compromise in print-through and maximum output level characteristics. Best tape for applications where both music and speech are being recorded.

#808 audio mastering tape has a back-coated polyester base, 1.5 mil thick. Has extremely low print-through characteristics. Ideal for speech, sound effects, and other applications where low print-through is required.

#809 audio tape offers the same performance as #808 but has a 1 mil thick back-coated polyester base to provide longer playing time. Product should be used where a combination of low print-through and long recording time is needed.

30, 60 and 75 minute AUD digital audio cassettes are engineered to deliver state of the art performance in the production CDs, record albums and cassettes. The AUD 30, 60 and 75 incorporate 3M's patented anti-static system.

## TAPE ACCESSORIES

### POLYLINE CORPORATION

Leader tapes, splicing tapes, special tapes (hold down, cleaning) splicing blocks, mylar splicing tabs, metal foil tabs, empty boxes, cassette loading supplies, labels, index cards, vinyl albums for audio cassettes, ring binders, cassette trays, paperboard albums. Bulk prices available on all products.

### TENTEL CORPORATION

T2-H7-AC Tentelometer measures the tension inside broadcast cartridges. The gauge accurately measures the tension inherent to that cartridge and makes it easy to sort "good" from "bad." It can also be used on 0.25-inch reel to reel recorders. The same "crooked" probes can be inserted onto "normal" 0.25-inch reel to reel tape, allowing accurate dynamic hold back and take up tensions to be measured. Helps locate and isolate causes of wow and flutter in reel to reel recorders. Scale range (dual range) is 0-7 ounces and 0-240 grams. Accuracy is  $\pm 0.1\text{oz}$  (0-20oz),  $\pm 0.2\text{ oz}$  (2-5oz),  $\pm 10$  percent above 5oz. Price: \$345.00

T2-L20-A is for 0.25 to 1-inch applications where in-line dynamic tape tension measurement is desirable at the lowest cost. Includes sheath vinyl case with belt loop, instruction manual and 1 oz. calibration weight on 0.25-inch tape. Price: \$265.00

T2-H20-ML is for 0.25 to 2-inch tape applications requiring minimal probe space. Includes fitted foam lined carrying case with instruction manual and 1 oz. calibration weight on 0.25-inch tape. Price: \$325.00

T2-H20-1 and T2-H20-2 work in applications up to 1-inch and 2-inch tape widths respectively. Accuracy can be calibrated to 2 percent of reading. Includes fitted foam lined carrying case with instruction manual and 1 oz. calibration weight on 1-inch tape (T2-H20-1) and 2 oz. calibration weight on 2-inch tape (T2-H20-2). Price: \$575.00 (T2-H20-1), \$675.00 (T2-H20-2)

### XEDIT CORPORATION

Blocks and kits, Otari replacements, edge-clamping types, flat-trough types, clear access blocks, Editabs-mylar foil sheets, razor blades, editing markers, magnetic-tape developers, texts on editing, drift and flutter meters, complete kits including blocks, tabs, cleaners.

"EC" series of precision blocks is ideal for handling and splicing very thin, fragile tape as utilized in the various digital formats. A flat bed, "edge clamping" configuration completely eliminates the characteristic lifting and shifting of thin tape due to static attraction. The patented design also provides continuous, clear access to the tape for splicing, while it is held securely in the block. Price: \$275.00 to \$350.00

20-P is a drift and flutter meter that measures subjective peak value, conforming to DIN and IEEE standards. RMS value conforming to JIS. Price: \$600.00

## CASES AND RACKS

### ANVIL CASES INC.

ATA are rugged, custom shipping containers intended for hard travelling requirements. Available in a variety of colors and customized configurations, the cases have been tested to the ATA Spec. 300, category 1 in addition to relevant military container and environmental specifications and standards. The cases can now incorporate a new option, M.I.C.S. (Modular Interlocking Case System), which allows totally removable clamp-on-lid designs to double as sturdy field work stations via a system of interlocking lids to side of case.

M.A.C.C. is a militarized and more rugged variation on the ATA.

Forge II are lighter duty local transport cases, available in numerous standard and custom configurations, and in three colors. Interiors are polyfoam treated.

### CALZONE CASE COMPANY

Escort is manufactured to exceed A.T.A specifications. It is constructed using either 1/4- or 1/2-inch luan mahogany plywood with heavy-duty Sessions hardware and a patented double angle. Exterior Wilsonart laminate available in a variety of colors.

Proline is constructed using the patented double angle design, but uses lightweight Sessions hardware for regional and local transport. Exterior construction is 1/4-inch luan mahogany plywood with a polytolene laminate in either black or gray.

Ultima series is manufactured with 1/4-inch plywood top and bottom with the patented double angle all the way around on the sides. It is lightweight and for local transport. The outer polytolene laminate is available in gray.

Convoy is constructed of 1/8-inch high impact ABS plastic which is molded to required dimensions, and is for local transport of lightweight equipment.

### FLIGHT FORM CASES

Flight Form is constructed with standard features and materials that include American-made plywood, high-impact ABS plastic, rivetless extruded tracking, domestically-made industrial hardware, recessed butterfly latches, handles and corners, aluminum piano hinge, positive interlocking top and bottom tongue and groove, key locks on hinged cases and high-density foam-lined interiors. This unit comes as an 18-inch amp rack case, configured for three to twenty spaces, and as an 11-inch effects rack case, configured for three to sixteen spaces.

Price: range from \$233.00 to \$424.00 (amp rack cases), range from \$224.00 to \$368.00 (effects rack cases)

Light Flight is constructed with standard features and materials that include American-made plywood, durable vinyl covering, rivetless extruded tracking, domestically-made industrial hardware, aluminum piano hinge, positive interlocking top and bottom tongue and groove, key locks on hinged cases and high-density foam-lined interiors. This unit comes as an 18-inch amp rack case, configured for three to ten spaces, and as an 11-inch effects rack case, configured for three to sixteen spaces. Price: range from \$198.00 to \$275.00 (amp rack cases), range from \$188.00 to \$313.00 (effects rack cases)

C-Series is constructed with standard features and materials including American-made plywood, durable vinyl covering, domestically-made industrial hardware, key locks on hinged cases, and high-density foam-lined interiors. This unit comes as an 18-inch amp rack case, configured for three spaces, and as an 11-inch effects rack case, configured for three to four spaces. Price: \$160.00 (amp rack cases), \$110.00 and \$115.00 (effects rack cases)

Standard features of the amp rack cases include measurements (19 1/8-inch left to right, 18-inch front to back rackable depth, and 1 3/4-inch equals one space), removable front and back covers, 1/4-inch plywood construction, small recessed latches on all Flight Form except three space, lock not included, and a 2-inch lid depth. Options include 3/8-inch plywood, exterior mounted latches, rear rack channel, 3-inch industrial caster, shock mounting, mixer top, removable casters. Custom configuration available.

Standard features of the effects rack cases are the same as for the amp rack cases except they have 11-inch front to back rackable depth and hook apart hinges. The options are the same.

## **FOUR DESIGNS COMPANY**

FX Rack is a 19-inch equipment rack that provides eighteen spaces. The all-wood design eliminates ground loop problems. The rack is very compact, using just over 2 square feet of space.

Son of FX was designed as a mobile work station on wheels. It offers two adjustable shelves, and ten units of rack space. The all-wood design eliminates ground loop problems. The rack is very compact, using just over 2 square feet of space. Price: \$139.95

Rackrate provides a low-cost method of securing rack-mountable equipment. It has a milk-crate design, steel reinforced, with threaded mounting rails, padded handles, and is guaranteed not to crack, chip or dent with the heaviest use. It can mount up to six spaces of rack equipment, and is 11.5 inches deep. For added protection, the steel handles project 2 inches beyond equipment front panels, and absorbs the shock of jolts encountered when loading or transporting equipment.

Rackdrawer is a two-space rack-mountable drawer that will fit into any 19-inch equipment rack. The design features special construction for durability. The drawer provides a convenient storage space.

Price: \$39.95

## **HYBRID CASES**

Roadie is constructed with a thick formica laminated to 1/4- or 3/8-inch top-grade mahogany plywood. Standard features include aluminum angle secured with machine-driven rivets, recessed twist latches, aluminum tongue and groove valences and steel ball corners.

Carpetbagger is similar to the Roadie but laminated with Olefin, a non-woven fabric that will not unravel, abrade or show wear. Available in 1/4-inch plywood only.

Original has a heavy vinyl covering laminated to 1/4-inch plywood. Aluminum angle is secured with machine-driven split rivets. Tongue and groove aluminum valences and metal corners are standard. Available with recessed or surface-mounted hardware.

Rack bag is constructed of 1/4-inch plywood rack shell, tapped rails, and shock-absorbing foam surrounding rackshell. Completely covered with nylon cordura with outside pocket and shoulder strap.

## **JOE'S SOUND AND SALAMI COMPANY**

Stack-Rack is a baltic birch cabinet that will not flex, which keeps the equipment chassis from being bent. It comes in black pebble or natural finishes, with Stac-Lock corners, and recessed Sessions handles. Front and back covers are optional. Available in sizes from four spaces and up.

Price: \$82.50 (4-space) , \$3.50 (for each additional space), \$7.50 (for black pebble finish), \$8.00 (for front and back covers)

## **STARCASE**

Ultra Star is constructed of 1/2-inch American-made AC grade plywood laminated with stucco glass-fiber. The deep groove valance assures alignment and positive closure, while inner/outer support extrusion ensures extra rigidity. Options include rubber/steel wheels (mounted on plywood caster boards), accessory compartments, keylocks, padlockable hasps, inner partitions, trays, drawers, stacking feet, cardholders and custom stenciling. Available in 11 colors. Exceeds ATA spec. 300, category 1.

Super Star features 1/4-inch American-made AC grade plywood laminated with stucco glass-fiber, and with deep groove valance to assure alignment and extra rigidity. Options are the same as Ultra Star. Exceeds ATA spec. 300, category 1.

ATA Star is constructed of 1/4-inch American-made AC grade plywood laminated with stucco glass-fiber, inner/outer support corner extrusion, and an inch of polyester foam on every interior surface to protect equipment. Options are the same as Ultra Star. Meets ATA spec. 300, category 1.

Carry Star is constructed of 1/8-inch top-grade plywood laminated with stucco glass-fiber, and inner/outer support corner extrusion. All hardware is exterior mounted and comes standard with an inch of polyester foam lining. Options include rubber/steel wheels (mounted on plywood caster boards), accessory compartments, keylocks, partitions, trays, drawers, stacking feet, cardholders, and stenciling.

## VIKING CASES

Standard ATA is available in 1/4- and 1/2-inch construction using furniture-grade plywood laminated to ABS (with heavy-duty Sessions hardware), stucco aluminum or glass-fiber. This model has double edge extrusion for strength and support and heavy-duty steel twist locks, corners and handles.

Norseman features ABS plastic laminated to 1/4-inch furniture-grade plywood with non-recessed hardware. Available only in black.

Carrylite features heavy-duty 1/8-inch ABS construction with non-recessed hardware and steel corners. Available in gray or dark blue.

Standard ATA rack cases are shock mounted with a 16-inch depth standard, and extra depth available.

## STANDS AND BOOMS

### ATLAS/SOUNDOLIER

MSX-10CE is a variable height microphone stand with integral two-position circular cast-iron base for stability and set-up/storage convenience, ebony tube finish. Height in use is 34- to 61-inch, for storage/transportation it is 38-inch with 10-inch diameter base. Weight is 11.4 lbs. Price: \$27.33

MS-25 is a studio stand with air-suspension system for microphone protection. It has over-size 1 1/8-inch dia. tube assembly and heavy 17-inch triangular base with chrome cover for stability, 38- to 67-inch height and weight is 23 lbs. Price: \$68.88

PB-20XE is an expandable length porta-boom in ebony finish with integral counterweight for microphone placement flexibility. 5/8-inch - 27 thread on mounting, and easily adjusts from 25.5- to 44.5-inch. Weight is 2 lbs. Price: \$21.05

SB-36W is a boom stand with grip-action clutch with integral air suspension system to counter-balance boom weight. 5/8-inch - 27 thread at microphone end. Boom length is 62-inch, and has adjustable vertical height of stand from 48-inch to 72-inch. It has a 17-inch dia. triangular base with rubber casters for mobility. It comes furnished with cable hangers. Weight is 36 lbs. Price: \$179.79

SB-10WE is a mini studio boom for overhead mic'ing of individual instrument or solo performer. It has a high-stability triangular base with ball-bearing casters for friction-free mobility. Horizontal boom length is 60-inch, vertical height is 43- to 68-inch, and weight is 26 lbs. Price: \$115.88

### BEYER DYNAMIC

Adjustable floor stands, ranging from 11.5- to 64.5-inch in height, are available with noiseless screw-type locking device, and screw-in or fold-away legs. Weight is from 4 to 9 lbs. Also comes in stand and boom combination. Price: range from \$48.00 to \$135.00

Adjustable floor stands are also available in heavy-duty form. Price: range from \$135.00 to \$200.00

Booms are available with adjustable, non-adjustable and heavy-duty boom arm from 18.5- to 83-inch, and slide adjustable with screw type locking device. Weight ranges from 2 to 10 lbs. Price: range from \$30.00 to \$100.00

### PEERLESS SALES COMPANY

040-815-02 is the "radial cube" speaker mount for speakers up to 100 lbs. It provides directional adjustability on both the vertical and the horizontal axis. Used for both wall and ceiling installation.

040-805-02 is for smaller speakers (20 lbs. or less).

### SOLID SUPPORT INDUSTRIES

AM-10 is an adjustable mixer stand constructed of powder-coated black 1- by 2-inch heavy wall steel. It will conform to mixers ranging in size from 27- to 47-inch wide and hold up to 250 lbs. Two cross bars utilize allen wrench type screws for width adjustment. It also has 4 casters (2 locking). Price: \$325.00



A modular stackable equipment rack is designed in 8 rack space modules, and can be expanded to accommodate additional equipment as needed. It is constructed of lightweight 1 1/4-inch powder-coated black steel tubing and can stack on top of one another for continuous rack spaces. It features recessed rack rails. SR-8A is a base unit with 4 casters (2 locking) and is slot fitted to the SR-8B modular rack unit. There is an optional 5/8-inch formica top. The units are open at the back and sides, allowing access to connections, and open air cooling of equipment. RS-2 is a 2 space rack shelf. Price: \$34.95 (optional top), \$55.00 (RS-2), \$110.00 (SR-8B), \$120.00 (SR-8A)

MP-10 is a multi-purpose stand designed for versatility and rugged use, and is height adjustable with pop-pin adjustment. Features include five-footed base for stability, wide range angle adjustment, high-tech casters (3 locking and 2 non-locking), and 4-inch Velcro straps to mount between the components and stand for added security. Weight is 11 lbs., and constructed of 1 1/4-inch heavy wall steel tubing, the unit will support up to 150 lbs. Price: \$115.00

Computer support series features solid, wide angle bases, and curved construction. The system is fitted with high-tech casters (2 locking and 2 non-locking), and has powder-coated black finish on all metal surfaces. Construction is of 1 1/4-inch heavy wall, and steel square tubing. The units include CS-10DS (single support with drop shelf), CS-20 (double tier support workstation system), CS-30 (triple tier support workstation system), and CS-DS (drop shelf support system).

## ULTIMATE SUPPORT SYSTEMS

HR-36BP is a home recording studio station. It comes with a six-receptacle electrical outlet strip. The table top is 42-inch, height is adjustable up to three feet and can be tilted for better access. The extra long support bars attach directly to the front and back tiers for stability, and support pins and rubber pads hold equipment in place. Price: \$280.00

Microphone Stand measures 40.5- to 66-inch and weighs 3 lbs. It is constructed of anodized aluminum tubing and durable plastics. Price: \$80.00

# ADDRESSES

AKAI  
1316 E. Lancaster  
Fort Worth, TX 76116

Calzone Case Company  
225 Black Rock Ave.  
Bridgeport, CT 06605

Otari Corporation  
378 Vintage Park Dr.  
Foster City, CA 94404

Teac Corporation (Tascam)  
7733 Telegraph Rd.  
Montebello, CA 90640

AMR  
PO Box 1230  
Meridian, MS 39301

Flight Form Cases  
13102 Stone Ave. N.  
Seattle, WA 98133

Peerless Sales Company  
1950 Hawthorne Ave.  
Melrose Park, IL 60160

Technics (Panasonic)  
One Panasonic Way  
Secaucus, NJ 07094

Agfa-Gevaert  
275 North St.  
Teterboro, NJ 07608

Fostex  
15431 Blackburn Ave.  
Norwalk, CA 90650

Polyline  
1233 Rand Rd.  
Des Plaines, IL 60016

Tentel  
1506 Dell Ave.  
Campbell, CA 95008

Ampex  
401 Broadway MS 22-02  
Redwood City, CA 94063

Four Designs Company  
6531 Gross Ave.  
Canoga Park, CA 91307

Solid Support Industries  
2453 Chico Ave.  
South El Monte, CA 91733

3M (Scotch)  
Bldg. 236-1B-06  
St. Paul, MN 55144

Anvil Cases  
4128 Temple City Blvd.  
Rosemead, CA 91770

Hybrid Cases  
1121-20 Lincoln Ave.  
Holbrook, NY 11741

Sony Professional Audio  
1600 Queen Anne Rd.  
Teaneck, NJ 07666

Uher of America  
7067 Vineland Ave.  
N. Hollywood, CA 91605

Atlas/Soundolier  
10 Pomeroy Rd  
Parsippany, NJ 07054

Joe's Sound and Salami Company  
303 Clymer Ave  
Morrisville, PA 19067

Starcase  
648 Superior  
Munster, IN 46321

Ultimate Support Systems  
PO Box 470  
Fort Collins, CO 80522

BASF  
19 Crosby Dr.  
Bedford, MA 01730

Mitsubishi Pro Audio Group  
225 Parkside Dr.  
San Fernando, CA 91340

Studer Revox  
1425 Elm Hill Pike  
Nashville, TN 37210

Viking Cases  
10480 Oak St. NE  
St. Petersburg, FL 33702

Beyer Dynamic  
5-05 Burns Ave  
Hicksville, NY 11801

Nakamichi  
19701 S. Vermont Ave.  
Torrance, CA 90502

TDK Electronics Corp.  
12 Harbor Park Dr.  
Port Washington, NY 11050

Xedit Corporation  
133 South Terrace Ave.  
Mount Vernon, NY 10550

# HOT LINE. . . . . to the experts.

Welcome to db's HOTLINE

*This is our forum for the many questions that we receive from you. Our experts will try to give you the answers whether you are asking about equipment or procedure in the recording studio, placement of equipment in a "live" venue in church or auditorium, design in sound reinforcement or some aspect of the broadcast medium. We cover the range of the audio world and we look forward to hearing from you.*

• I have never aligned a multi-track machine. I have worked on many 2-track/1/2-track stereo machines, and am geared pretty well for that. I am used to checking phase and levels, etc., using a "scope" along with audio analyzer, etc.

How does one check phase and levels on a multi-track machine? Is this a "stupid" question, since multi-tracks are never recorded at the same time, nor with the same information in radio production, and thus phase coherence is not important? If phase between the various tracks is to be checked, must one use a multiplexer on a scope in order to get the multi-traces?

I would sincerely appreciate any information which you may care to share with me on the subject.

Carl Shelenberger

Ft. Walton Beach, FL

Calibration and alignment are done on a multi-track tape machine the same as on a 2-track machine. You'll need a standard alignment tape of the proper tape width. This tape will be full track, even for a multi-track machine. Such tapes can be obtained from Ampex, Standard Tape Laboratories, and others. Some sources may be recommended by the recorder manufacturer.

Considering only the effect of phase shift on stereo reproduction, the phase shift between tracks on a multi-track machine is critical only for stereo pairs--say, a stereo drum mix on tracks 3 and 4 of an 8-track tape.

The phase shift between tracks is a highly sensitive indicator of azimuth alignment. Azimuth is correctly set by watching for minimum phase shift between tracks. Then the head gaps are perpendicular to the tape and high-frequency response is maximized.

You need to check the phase shift only between the upper and lower tracks (say, tracks 1 and 8 of an 8-track machine). No multiplexer is needed.

Here's a typical head-azimuth alignment procedure:

1. Clean and demagnetize the heads.
2. Thread the alignment tape on the machine.
3. Play the 15 kHz tone on the tape.
4. Adjust the playback-head azimuth for maximum output on all channels. Since some track signals will rise while others will fall on either side of the correct setting, this will be a compromise adjustment. At the correct alignment, the peak is sharp with smaller, broader peaks on either side of the main peak.

5. Connect the upper track output to the vertical input of an oscilloscope. Connect the lower track output to the horizontal input. For example, in an 8-track machine, connect tracks 1 and 8 to the 'scope.

6. Fine-adjust the playback-head azimuth for minimum phase shift between those tracks. When the two channels are in phase, the scope display will be a straight line sloping up 45 degrees to the right. When they are 90 degrees out of phase, the display will be a circle. When they are 180 degrees out of phase, the display will be a straight line sloping up 45 degrees to the left.

7. If your machine combines the record and playback heads in a single head, you're done. Continue with bias and EQ adjustments. For efficiency, feed signals to all tracks simultaneously.

8. Otherwise, play the alignment tape with your tape machine set in sync mode. Adjust the record-head azimuth in the same way. Then continue with the rest of the calibration. Good luck!

Bruce Bartlett

Senior Mic Development Engineer  
Crown International

*HOTLINE! will be a regular feature of each issue to come. It is your direct forum to the industry's experts for the answers to the audio problems you face. Write to HOTLINE!, db Magazine, 305 Commack Road, Suite 1010, Commack, NY 11725. All letters become to property of db Magazine.*



# Lab Report

## Yamaha MT2X Multitrack Cassette Recorder

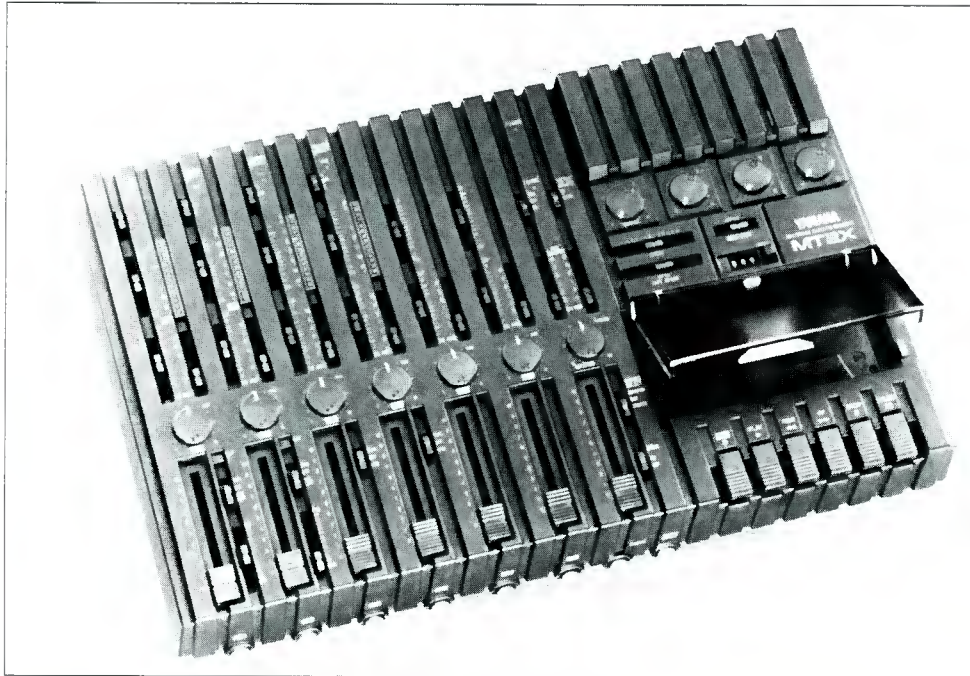

### GENERAL INFORMATION

• The Yamaha MT2X is, first and foremost, a six-channel mixer with four output channels, two of which may be regarded as a stereo pair. In addition, the MT2X is a multi-track cassette recorder. The recorder, unlike conventional home cassette decks, allows you to record on any or all of the four available tracks of a cassette, as you choose. As a result, cassettes employed in the MT2X can only be recorded in one direction. Of the six input channels found on the MT2X, only the first two may be used as microphone inputs. The first four may also be used either as line inputs or to control tracks one through four during tape playback. The remaining two inputs may be used only as line inputs during use of the product as a mixdown console. Low and high frequency equalizer controls are associated with each of the six input channels, and these controls may also be used to adjust tonal

balance during playback of previously recorded material. Pan pots associated with each of the six input channels allow you to assign each input to the left or right stereo outputs or to any point in space in between. Aux send and return controls and jacks are provided for sending and receiving special effects devices such as reverb units. Amplified monitor speakers can also be connected to the AUX SEND jack.

*Yamaha YMC2 MIDI/FSK Converter.*

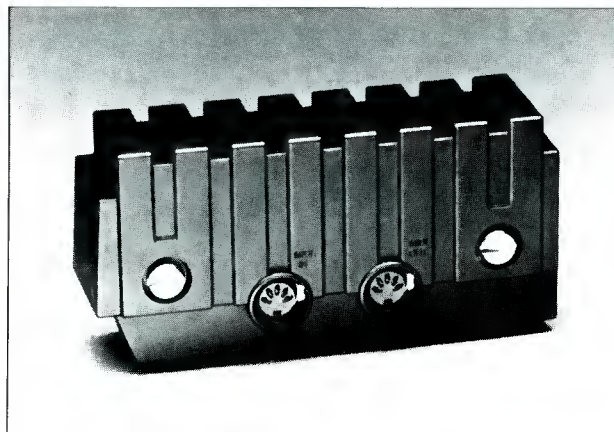

For synchronized operation with MIDI (Musical Instrument Digital Interface) instruments, an optional plug-in MIDI converter enables synchro-operation of the MT2X and instruments such as the Yamaha RX-series digital rhythm programmers and the QX-series digital sequence recorders.

### CONTROL LAYOUT

Controls of the MT2X are divided into four major operating areas of the unit: the mixer section, the recorder section, the meter and monitor section

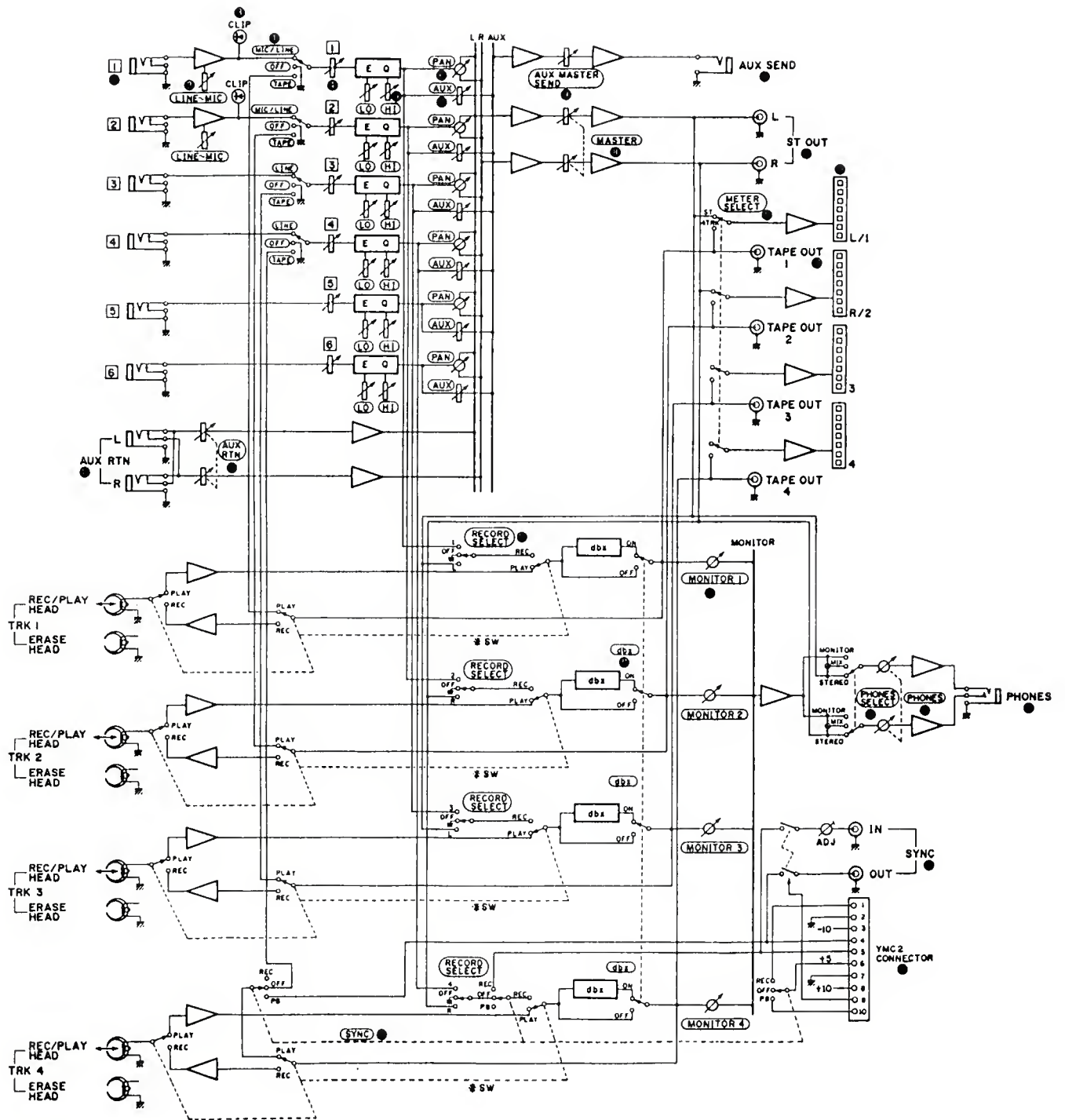
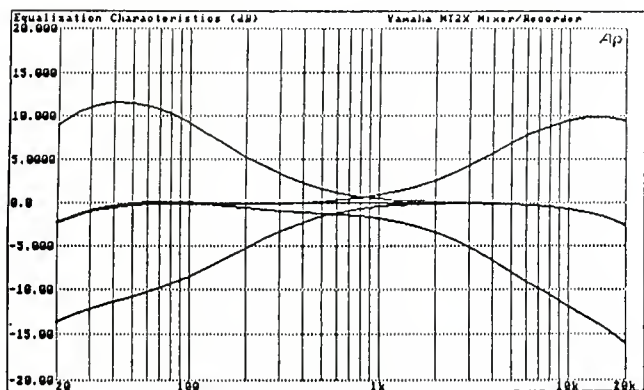

Figure 1. The block diagram.

and the connection section. The block diagram of *Figure 1* shows how signals flow through the entire unit. While superficially the six input modules seem identical, in fact they are not. Only input channels 1 and 2 accept microphone inputs and so only these input channels have slider gain controls in addition to the input faders common to all six input channels. These extra gain controls permit the first two channels to be adjusted over a range from -10 dB to -50 dB in order to accommodate low-level mic signals as well as line level signals. Inputs channels 1 through 4 all have line/off/tape slide switches since the controls for these can be used to control playback of any or all of the four recorded tracks on the cassette deck section. Inputs 5 and 6 can only be used as line in-

puts. All six input channels are equipped with low and high frequency equalizer controls that work either on input signals or during playback of previously recorded tapes. L/R pan pots are also provided for each of the six input channels as are Aux Send slider gain controls. A master fader control, an Aux master send control, an Aux Return control, a sync switch (normally set to "off" unless the unit is being used for synchronized operation with MIDI products as discussed earlier) and a power on/off light complete the mixer section control layout.

Record select switches near the top of the first four channel modules can be set to record on any one of the four available tracks or, if set to "L" and "R," they correspond to



Equalization characteristics, Yamaha MT2X Multitrack Cassette Recorder, (controls set for maximum boost and cut)

Figure 2.

stereo left and right signals. Record Ready lights for each of these channels blink when the record select switches are used to set one or more of the tracks to the record standby mode and light continuously when recording is actually in progress. Below the tape compartment are the familiar "piano key" tape transport buttons common to any cassette recorder, including *Record, Play, Rewind, Fast Forward, Stop* and *Pause*. A dbx on/off switch is found alongside the master

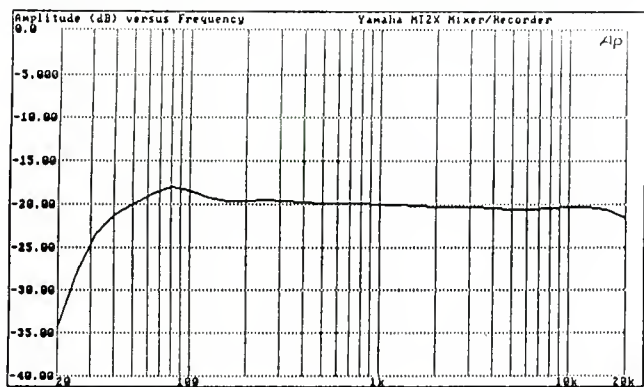

Frequency Response, record/play at 9.5 cm/sec, -20 dB record level, Yamaha MT2X Multitrack Cassette Recorder

Figure 4(A).

fader control. Above the tape compartment are a three digit tape counter and reset button, a "memory rewind to zero" on/off switch, a tape speed selector (the cassette recorder operates at both 4.8 cm./sec. and at 9.5 cm./sec., or double the standard 1-7/8 in./sec. cassette speed) and a slider control that adjusts pitch by approximately 10 percent in either direction. The pitch control works both during recording and

Figure 5(A).

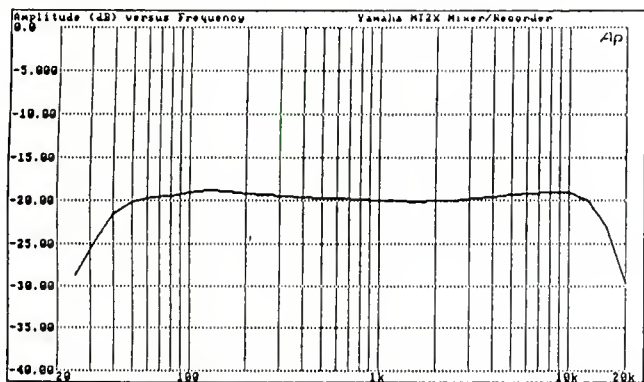

Frequency Response, record/play at 4.8 cm/sec, -20 dB record level, Yamaha MT2X Multitrack Cassette Recorder

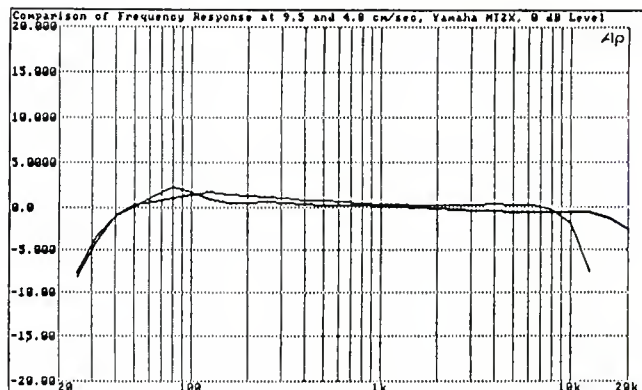

Record play frequency response, at 0 dB level, Yamaha MT2X. Earlier roll-off occurs at slower (4.8 cm/sec.) speed.

Figure 3.

playback. This feature is particularly useful during overdubbing, since the pitch of previously recorded tracks can be altered to match that of the new track or tracks being added.

Controls associated with metering and monitoring include a meter select switch (stereo or 4-track), four individual LED peak level meters consisting of 14 LED indicators, a *Phones Select* switch that can be set to *Stereo* (for monitoring the signals coming out of the *Stereo Out* jacks), *Monitor* for moni-

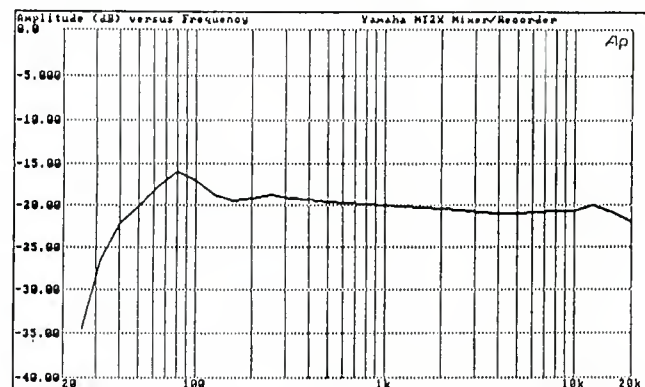

Frequency Response, record/play at 9.5 cm/sec, -20 dB record level, dbx ON, Yamaha MT2X Multitrack Cassette Recorder

Figure 4(B).

toring the output of each of the four tracks during recording or playback using the four rotary monitor controls located at the upper right corner of the top surface of the MT2X), and a phone master volume control.

Six standard phone plug input jacks are found along the front edges of the unit, together with the stereo phone jack and a punch in/out jack to which an optional foot switch

Figure 5(B).

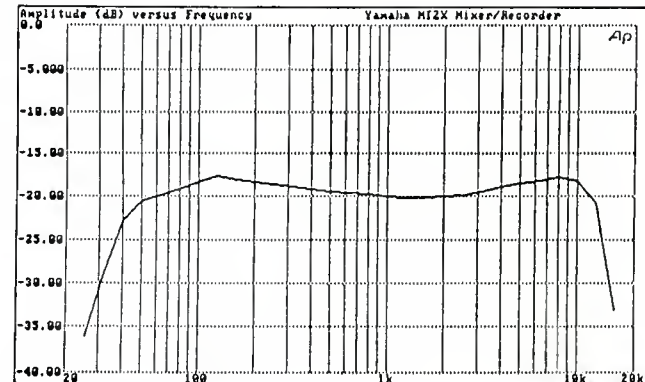

Frequency Response, record/play at 4.8 cm/sec, -20 dB record level, dbx ON, Yamaha MT2X Multitrack Cassette Recorder

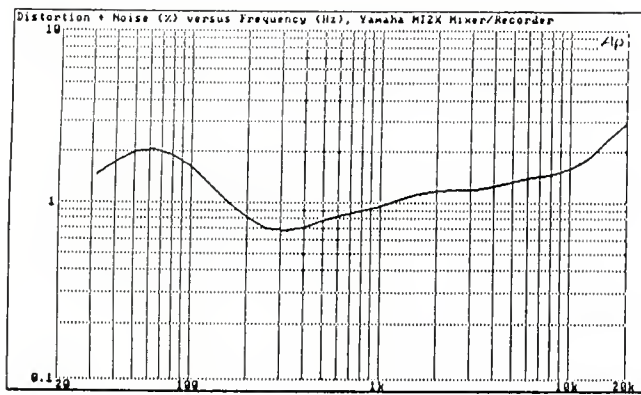

Distortion vs Frequency Yamaha MT2X Multitrack Cassette Recorder, at 9.5 cm/sec

Figure 6(A).

(Yamaha Part No. FS-1) can be added for controlling punch in/out operation by foot. The rear panel of the MT2X houses its power on/off switch, four tape output jacks that feed the output of the four individual tracks during playback or the signals of the tracks being recorded during recording, stereo output jacks that deliver the mixed signals of each channel and each track in stereo, and Aux Send jack, the two Aux Return jacks, Sync/In and Sync/Out jacks and the special multi-

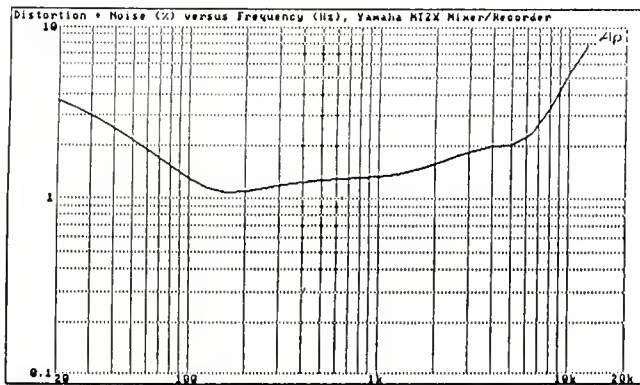

Distortion vs Frequency Yamaha MT2X Multitrack Cassette Recorder, at 4.8 cm/sec

Figure 7(A).

pin connector that accepts the YMC2 MIDI Converter discussed earlier.

### LABORATORY MEASUREMENTS

There aren't too many meaningful measurements of the mixer section that we could make other than to confirm input and output levels, as shown in the VITAL STATISTICS

Figure 8(A).

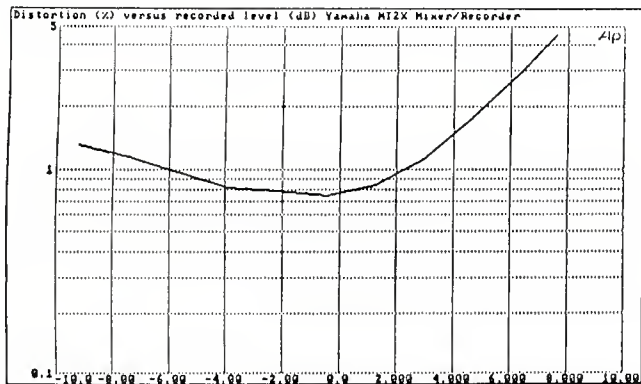

Distortion versus recorded level, Yamaha MT2X, at 9.5 cm. per second.

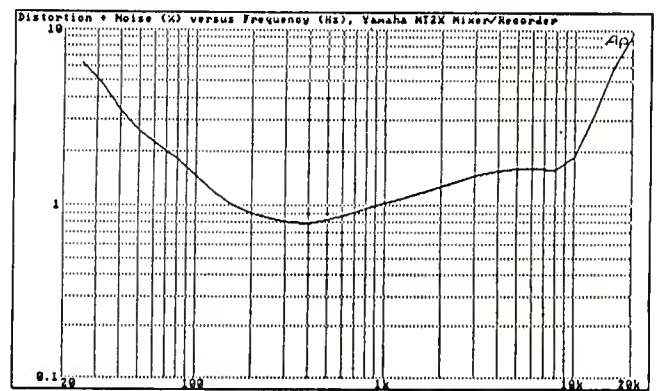

Distortion vs Frequency Yamaha MT2X Multitrack Cassette Recorder, at 9.5 cm/sec, dbx ON.

Figure 6(B).

table that appears at the end of this report. Most of our tests involved the performance of the cassette recorder section. Before beginning those tests, however, we did measure the basic frequency response of the electronics of the mixer as well as the range of the equalization controls associated with each input channel. Using our computerized test setup, we made a series of successive frequency sweeps from 20 Hz to 20 kHz. The center curve in Figure 2 shows that the basic

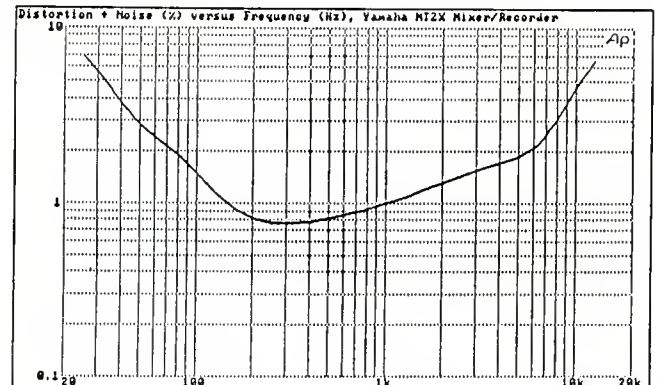

Distortion vs Frequency Yamaha MT2X Multitrack Cassette Recorder, at 4.8 cm/sec, dbx ON

Figure 7(B).

overall frequency response of the electronics of the MT2X is flat over most of the audio range, and is down only about 2.5 dB at 20 Hz and 20 kHz. Maximum bass equalization measured  $\pm 9.0$  dB at 100 Hz, while maximum range of the high frequency EQ control yielded a maximum boost of +9 dB and a maximum cut of -12 dB at 10 kHz.

Figure 8(B).

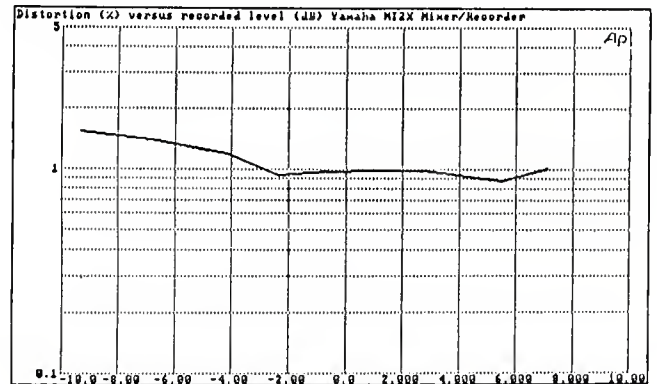

Distortion versus recorded level, Yamaha MT2X, at 9.5 cm. per second, with dbx ON

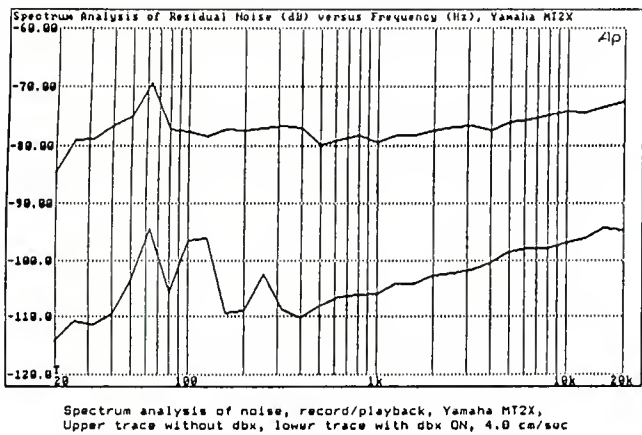

Figure 9(A).

One of the advantages of operating a cassette deck at higher speeds than the standard 1-7/8 in./sec. (4.8 cm./sec.) is improved frequency response, particularly at maximum (0 dB) recording levels. To illustrate this advantage, we superimposed two record/playback frequency response measurements in Figure 3. Both sweeps were recorded at 0 dB recording level using Maxell XL-II (High Bias, 120 usec EQ) tape. Normally, response measurements for cassette tape decks are made at -20 dB recording levels to avoid the high-frequency saturation effects characteristic of cassette decks operating at high recording levels and at 1-7/8 in./sec. Indeed, examining Figure 3 you can see that while low-frequency roll-off was almost the same at both operating speeds, at the slower 4.8 cm./sec. speed, roll-off began at around 10 kHz, or a full octave lower than when the recorder was operated at its higher speed. This is exactly the result you would expect, since, with the tape moving twice as fast, the linear distance along the tape occupied by one cycle at 20 kHz is exactly the same as the linear distance required for one cycle at 10 kHz at the slower speed.

Reverting to the more normal frequency response measurement procedure at a -20 dB recording level, response at the 9.5 cm./sec. speed extended from 33 Hz to above 20 kHz for the -3 dB roll-off points, as shown in Figure 4A. Figure 4B illustrates an interesting aspect of dbx noise reduction, however. For all its advantages in reducing tape hiss and improving dynamic range, if there is any inherent variation in response in a recorder, using dbx will tend to amplify those variations in amplitude. The slight rise in response at 80 Hz seen in Figure 4A (without dbx) amounted to about 2 dB,

Figure 10(A).

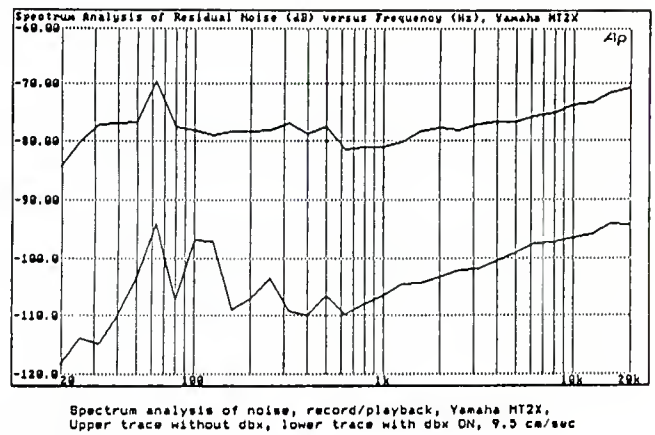
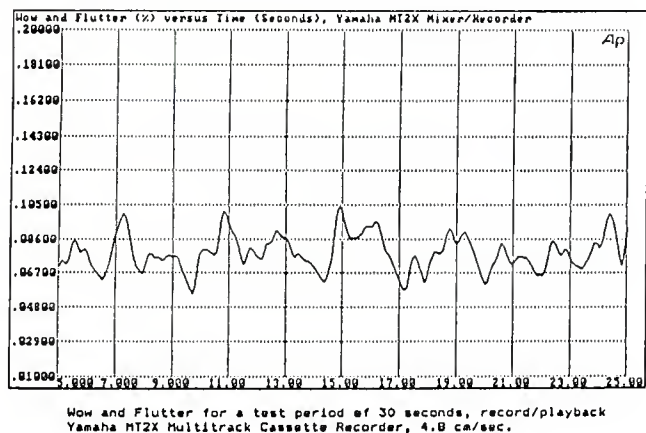

Figure 9(B).

but when the same sweep recording was made and played back with dbx turned on, the "bump" at 80 Hz was doubled to around 4 dB, as shown in Figure 4B.

The same sort of comparison was made for the slower, 4.8 cm./sec. speed and results are shown in Figures 5A and 5B. In Figure 5A response was within the -3 dB cut-off point from about 38 Hz to 14 kHz and the slight rise in response observed at about 130 Hz and at 10 kHz amounted to no more than 1 dB or so. Turning on dbx not only resulted in a somewhat earlier roll-off at the low and high frequency extremes, but also exaggerated the positive "bumps" in the response so that they were now about +2 dB above the -20 dB reference level at which the recording was made.

While Yamaha specifies harmonic distortion plus noise (less than 1 percent) only at a 315 Hz, we plotted distortion over the entire audio range. As shown in Figure 6A, THD plus noise did, indeed, measure only 0.7 percent at 315 Hz (for a 0 dB record/playback level), using the higher tape speed. However, at the frequency extremes, THD plus noise was considerably higher (2 percent at 14 kHz), as might be expected. Interestingly, with dbx turned on for such a test, as plotted in Figure 6B, while center frequency THD plus noise hardly changed at all, distortion at the frequency extremes actually got worse, reaching more than 3 percent at 14 kHz.

The effect of dbx on distortion at high and low frequencies, though not as pronounced, is nevertheless present at the slower recording speed as well, as evidenced by the two plots of Figures 7A and 7B. In this case, dbx served to lower THD at mid frequencies just a bit, but caused an increase in THD below 100 Hz.

Figure 10(B).

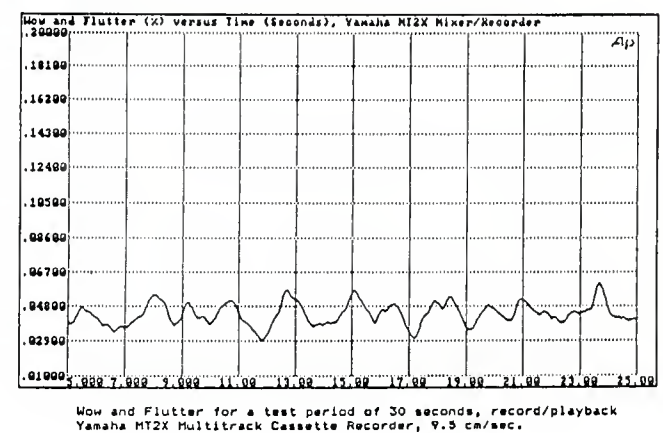

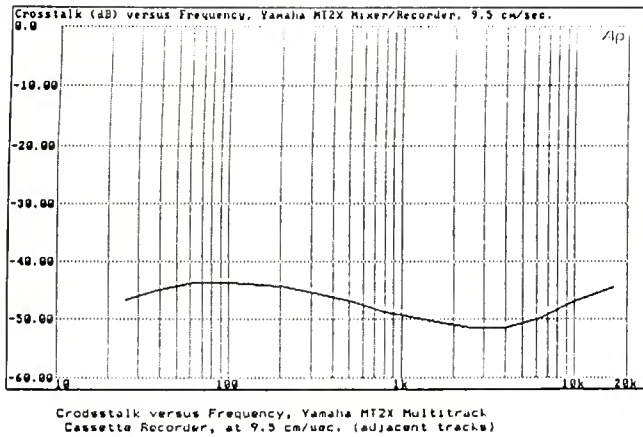

Figure 11.

One of the most important positive results of using dbx (besides its obvious improvements in signal-to-noise and dynamic range) is its effect upon high-level recording at mid-frequencies. *Figure 8A* is a plot of THD versus recording level, plotted for a 1 kHz recorded signal from a -10 dB level to around +8 dB. The nominal 3 percent THD point was reached with a recording level of slightly more than +6 dB (referenced to the LED meter readings on the Yamaha MT2X unit.) When the same test was repeated with dbx turned on, THD remained around the 1 percent point even up to +7 dB, the highest recording level used in this test. These results are plotted in *Figure 8B*.

Yamaha claims an A-weighted signal-to-noise ratio of 85 dB through the record/play cycle, with dbx turned on. At the 9.5 cm./sec. tape speed, the best we could come up with was 78 dB, but that's quite a remarkable S/N figure for any cassette deck, and the difference between our reading and Yamaha's claim could well be attributed a difference in tapes used to conduct the test. S/N is always somewhat tape dependent and we have no way of knowing what tape was used by Yamaha in calibrating this machine. In any event, we also measured S/N at the slower speed and obtained a reading that was only 1 dB poorer (with dbx on), or 77 dB. Without dbx, S/N measured 57 dB at the 9.5 cm./sec. speed and 51 dB at the slower speed.

We also analyzed the nature of the residual noise at both operating speeds, using the spectrum analyzer feature of our test equipment. Results for the 4.8 cm./sec. speed are shown both without and with dbx in *Figure 9A*, while results obtained at the 9.5 cm./sec. speed are plotted in *Figure 9B*. Note that in both cases, dbx lowers the noise at all frequencies by 20 dB or more, unlike Dolby B, which reduces noise primarily at the higher, tape hiss frequencies. With this type of sensitive analysis, it becomes very easy to pinpoint the source and frequency of major noise contributions. For example, we

can see the major contribution of the 60 Hz AC power supply and, when dbx lowers the actual tape noise, evidence of 120 Hz ripple (at a lower level) also becomes apparent.

*Figures 10A* and *10B* are time plots of wow-and-flutter at 4.8 cm./sec. and 9.5 cm./sec. tape speeds, respectively. Wow and flutter averaged about 0.045 percent at the higher speed, but increased to an average of around 0.075 percent at the slower tape speed. Finally, we measured cross-talk between adjacent tracks as a function of recorded frequency. Results are shown in *Figure 11* and we were quite pleasantly surprised to find that cross-talk was a high 50 dB at 1 kHz and remained well above 45 dB even at 10 kHz.

## CONCLUSIONS

Clearly, this little mixer/recorder combination is no substitute for even the most modestly equipped professional recording studio. On the other hand, what a great tool it can be for the performing group that needs an inexpensive way to produce demo cassettes, do some creative mixing and multi-track recording and the like. The excellently written, 38 page owner's manual supplied with the MT2X is a little gem of a guide to multi-track recording techniques, offering step-by-step instructions that even the uninitiated will be able to follow easily. Even ping-pong recording, sometimes called bouncing or track-transfer is illustrated. This technique, made possible by the flexible recording track selection capability of the MT2X, allows you to re-record three tracks onto the remaining fourth track of the recorder, thereby releasing tracks for other recording operations. You can add other parts during the ping-pong process. As long as there are empty tracks, you can ping-pong or transfer from one or more tracks to another as many times as you like. Of course, each time a track is ping-ponged onto another track, some degradation in sound quality (chiefly at the higher frequencies) and signal-to-noise ratio results. Punch-in/punch out techniques are also amply illustrated and easily executed with this machine. In short, many of the more sophisticated mixdown and other multi-track recording techniques long associated with commercial (and expensive) recording studios can be duplicated with this versatile multi-track cassette recorder at a cost that does not exceed a few hours of studio rental time. That having been said, however, don't expect the Yamaha MT2X to give you the kind of sound quality obtainable from a full professional recording studio setup. The MT2X fills a definite need for the less than affluent musicians and groups who need an inexpensive way to create demos. It may even be a handy product for some more affluent groups to keep around just so that they can play around with new ideas, new mixdowns and the like without dissipating some of that affluence. □





# VITAL STATISTICS

SPECIFICATION	MFR'S CLAIM	db MEASURED
<b>Tape Transport Section</b>		
Tape type	70 $\mu$ sec EQ	Confirmed
Tape Speeds	4.8/9.5 cm/sec	Confirmed
Pitch Control	$\pm 10\%$	+ 10/-11%
Wow & Flutter	0.05% WRMS	0.045% @ 9.5 cm/sec
Fast Wind Time (C-60)	100 sec.	120 sec. (C-90)
<b>Connectors</b>		
Nominal input levels	-10 dB	Confirmed
Nominal output levels	-10 dB	Confirmed
Phones output level	100 mW/8-40 ohms	Confirmed
Aux Send level	-10 dB	Confirmed
<b>Electrical</b>		
<b>Equalizer</b>		
High	$\pm 10$ dB @ 10 kHz	+ 9/-12 dB @ 10 kHz
Low	$\pm 10$ dB @ 100 Hz	$\pm 9$ dB @ 100 Hz
<b>Frequency Response</b>		
@ 9.5 cm/sec 40 Hz-18 kHz, +/- 3 dB	33 Hz - Above 20 kHz	
@ 4.8 cm/sec 40 Hz-12.5 kHz, +/- 3 dB	38 Hz - 14 kHz	
S/N Ratio (dbx ON)	85 dB, A-weighted	78 dB, A-weighted
Channel Separation	55 dB at 1 kHz	50 dB at 1 kHz
Distortion	Less than 1% @ 315 Hz	0.07% @ 9.5 cm/sec
Erase Ratio	70 dB @ 1 kHz	72 dB
<b>General Specifications</b>		
Power Requirements	120 V, 50/60 Hz, 23 W.	Confirmed
Dimensions (WxHxD)	16-1/4x3x10-1/4 inches	Confirmed (41.3x7.5x26.0 cm)
Weight	7.7 lbs. (3.5 kg)	Confirmed
Price: \$ 845.00 (MIDI Converter, \$105.00)		

## Department of Errata

In our January/February Buyer's Guide we inadvertently left out Formula Audio. Here it is. Formula Audio's address is Rt. 5, Box 440-3 Hwy. 39, Zebulon, North Carolina 27597.

Model	Dimensions, H,W,D	Cabinet Finish	Impedance, ohms +/- dBs	Frequency Response	Bass Speaker Size, in.	Bass Speaker Type	Midrange Speaker Size, in.	Midrange Speaker Type	High-Frequency Driver Size	High-Frequency Driver Type	Crossovers(s)	Price	Features
FORMULA AUDIO													
4402	36X19 x22	8 16	43-20	15	cone	2	CD	slot	800 8k			\$1899.00	675 watt power at 8 ohms.
4403	36x36 x22	4 8	43-20	15	cone	2	CD	slot	800 8k			\$3199.00	Two low, mid, and high drivers, 1350 watt power rating.
4418	36x36 x22	8	26-2k	18	cone				80			\$1499.00	600 watt power rating. Also available with 2 18-in. drivers as model 4428, \$1799.00.
M112	15x24 x18	8 16	55-18	12	cone			1	CD	1.5		\$899.00	Monitor system, 325 power rating at 8 ohms.
P6000	60x22 x24	4 8 16	26-20	10	cone	2	CD	slot	250			\$4699.00	Includes a 24 dB active 3-way x-over and 1800 watt 3-way power amp. Has dual midrange and high drivers.

# Recording Liza Minnelli — The Challenge

**I**n planning the live recording of Liza Minnelli in Carnegie Hall, my primary goal was that with which I approach all Telarc recordings: the natural, accurate recreation of the actual musical event as it happened, in time and space. I was determined to make it work in

accompanies a show such as this and includes not only the main house system for the audience but also a multitude of on-stage monitors for the benefit of the performers. Other noise problems included air conditioning rumble, stage lighting cooling fans, audience and orchestra noise and the fabled "Carnegie Hall Sub-

the signal from all the sound reinforcement systems mics on stage; or B) take the signal from all stage mics directly out of the mixing console of the sound reinforcement system. Since Telarc is not known for following "standard industry practices" in its approach to recording sound, I knew from the beginning that I would choose a third, even



Figure 1. The mic setup on the Carnegie stage.

spite of numerous major problems to be overcome, the primary one being the large sound system which always

*Jack Renner is the chief recording engineer, as well as Chairman and CEO of Telarc International Corp..*

way."

I was all too aware that there are certain "standard industry practices" which engineers from most record companies would follow to produce a master tape. The most commonly followed approach would be to: A) split

more difficult approach: setting up a recording system which was completely (well, almost, see the next paragraph) independent of the sound reinforcement system. In this way, the integrity of the live sound was preserved the "Telarc way."

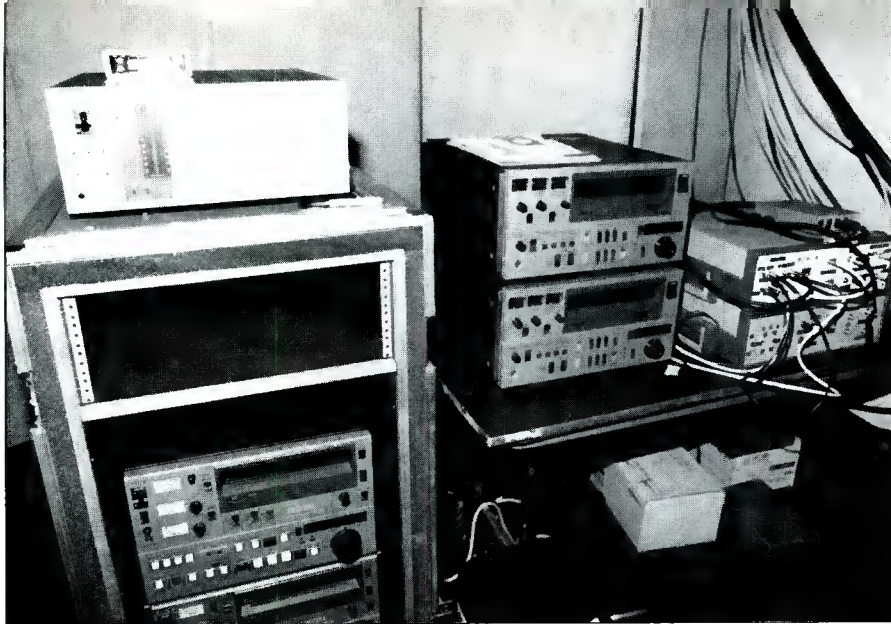

Figure 2. The recording gear was setup in a room adjoining the stage.

(The only area that was not under my total choice and control was Liza's mic. In this case, we were not able to double up. It was possible, however, to take a direct line out of her wireless mic, maintaining complete isolation from the sound system.)

While I went to great lengths to minimize the effects of the sound system and its associated equipment, it was absolutely essential to enlist the cooperation of the reinforcement engineers in order to achieve maximum effectiveness under the circumstances. Lucas Corubbia and Joseph Pavone of Altel Sound were simply marvelous in their willingness to work with us to create the best possible situation for *all* concerned. They spent time every day tailoring the sound and coverage of their systems in order to provide us with the most workable situation, while still accomplishing their goals. The biggest problem, of course, was just the sheer **LOUDNESS** of their combined systems and how it related to and interfered with our goal of capturing as much live, natural sound as possible.

To achieve a natural sound, a "modified" Telarc approach was chosen which involved giving up the use of my favorite "three spaced omnis." Instead, I chose four spaced directional mics — the marvelous new Sennheiser Model MKH-40. This provided some control over the amount of sound system(s) actually picked up on stage. The Sennheisers, although having a directional characteristic, have a very warm, natural sound and plenty of low-end response. The lay-out of the orchestra was such that four, rather than three,

provided the most realistic re-creation of the sound stage.

The superb orchestra arrangements require a lot of inner detail and solo work to be heard through the full orchestra and really "cooking" rhythm section led by leader/drummer Bill



Figure 3. The Neotek console and monitoring equipment.

LaVorgna. Various spot mics were chosen for their known characteristics and resulting ability to compliment the instrument(s) they were being used to highlight.

To maintain perfect signal integrity from the microphones to the mixing console, the latest in high-performance

microphone cable from Monster Cable was used. This is the first recording of a pop performer which utilizes Monster Cable in the entire signal path, as well as our specially-designed Neotek transformer-less mixing console. The Neotek, wired with Monster Cable, is another industry first.

---

The nine mic stands on stage had to be spray-painted "Carnegie Hall Gold" in order to blend in with the color scheme on stage.

---

I also broke with "standard industry practice" in deciding not to use a limiter or compressor on Liza's voice. These are analog devices which maintain a more or less constant level in the signal, thereby insuring (when properly used) that the loudest passages will not overload and the softest will not be buried under the orchestra. As you know, it is against our practice to use

analog signal processing devices. In addition, were a device such as this to be utilized during the live recording, that's it, forever. There is no going back later and "un-compressing." In order to achieve the same end in a natural way, I *did* manually follow her voice levels to a limited degree as she moved in and

out from her mic. To do any less would have made an impossible recording.

Perhaps the biggest break with industry practice is the fact that this is not a multi-track recording; the finished product was produced from the 2-track digital master mixed during the recording of the performances. To suggest that the engineering of this project was the proverbial "piece of cake" would be very misleading. Having outlined the philosophy behind my approach and having described the physical set-up, I hasten to point out that having accomplished all of these things, the actual carrying out of the recordings still presented tremendous challenges. The sound systems were still *way* too loud; they produced hum and distortion. Liza's wireless mic (all wireless mics) had a limited dynamic range and tended to overload. While we were able to record one concert with a wired mic using her capsule, musical decisions required that most of the final release would come from the wireless. Carnegie Hall, while a wonderful acoustic, provided a great

amount of reinforcement of the 47-piece orchestra (and not to her). The other noise producers mentioned above added their own "sounds." I feel good that through the cooperation of the people responsible for the operation and control of some of the major mechanical noise producers we were able to minimize their effort considerably; otherwise, we worked around them as best we could.

For those of you concerned with trivia, the following should be of interest:

- We utilized over 4,000 feet of Monster Cable microphone cable in order to make the runs from stage to our make-shift control room in the basement of Carnegie Hall.

- The nine mic stands on stage had to be spray-painted "Carnegie Hall Gold" in order to blend in with the color scheme on stage. Certain portions of our Monster Cables received the spray treatment as well.

- In six nights of recording, we did not experience any equipment failure.

- In order to provide a comfortable performing environment on stage for Liza, the hall was cooled each night to the lowest temperature possible to compensate for the heat generated by the crowd of 3,000 and of 21 spotlights on stage. The hall stayed comfortable. Not so in the control room which was on the same air conditioning system. Our space remained at a constant 58 degrees Fahrenheit! It was very odd seeing winter dress in the middle of a June heat wave in New York.

The entire production was a cooperative effort which involved not only Telarc's crew, but also Liza's entire crew, the orchestra members, the stage crew at Carnegie Hall, and extraordinary support from the folks at Sennheiser, Monster Cable, B&K and Audioforce. I hope you will agree that we have captured the feel and essence of an exciting performance in a real acoustical space with all the feeling of "being there." db

## TECHNICAL INFORMATION

Orchestra

4 Sennheiser MKH-40 for overall coverage

Spot for solo and highlighting

**Piano:** 2 Bruel & Kjaer 4006

**String bass:** Bruel & Kjaer 4007

**Harp:** Schoeps MK-2S

**Percussion:** 2 Schoeps MK-4

**Winds:** 2 Schoeps MK-4

**Ambience:** 2 Schoeps MK-3

**Vocal:** Vega wireless diversity with Shure SM-87 capsule, Shure SM-87, Sennheiser wireless diversity lavalier (opening sequence second act)

Downstage-opening sequence, second act: 2 Schoeps BLM-3 boundary layer

The entire signal path from microphones to digital processors utilized Monster Cable, including M1000, Series I Pro-link and Series III Pro-link bandwidth balanced.

**Mixing console:** Neotek Series I custom built and wired with Monster Cable III bandwidth balanced

**Control room interconnects:** Monster Cable M1000 and MI

**Digital recording processors:** Sony PCM 1630

**Monitor speakers:** ADS Model 1530

**Amplifier:** Threshold S-500 Stasis/II with optical biasing

**Control room acoustic treatment:** Sonex from illbruck/usa, Soundex from Monster Cable and tube traps from ASC

# Coverage Uncovered

*"This will push the sound all the way to the rear." "These horns have 90 degree coverage." "It will be loud enough for everyone to hear just fine."*

Such statements, as those above, are still commonly made by sound men to reassure the client (and perhaps themselves as well!) that audience coverage will be satisfactory. What they really indicate, however, is that the sound man knows very little about the actual coverage, and may care even less.

This has always been a perplexing attitude. Sound professionals will listen for hours to evaluate a new driver or effects device. They will seize on any perceived distortion or noise as a fatal flaw. They will settle for nothing less than the best in clarity and definition. They may even carefully equalize their system for the finest possible sound as they hear it, at least at the console. Sometimes they will walk around the house for a few minutes, listening and shaking their heads, then complain about what the room is doing to their sound.

In fact, they have probably done most of the damage themselves. It is possible to get very even sound coverage, at all frequencies, throughout the audience area in almost every venue. It may not be easy, but, as they say, nothing worthwhile ever is.

Why are most sound professionals so indifferent about coverage? Sometimes it seems they just forget about the audience and set up the system for themselves alone. Most likely they don't do anything about it because they just don't know what to do about it.

## WHAT TO DO?

Poor coverage can't be corrected simply by buying another piece of equipment. This doesn't mean that there is no equipment that can help. In fact, all the hardware necessary to solve almost any coverage problem has been

available for many years. The problem comes in trying to figure out exactly what to use and how to use it.

This brings up another consideration. Most sound problems can be overcome by the cut-and-try approach: simply try another item of equipment, or combination of items, and see if it sounds better. If so, use it; if not, try something else. Unfortunately, this just doesn't work in dealing with most coverage problems. First, the situation is usually too complicated for intuitive

help. Such is the rationale which led several manufacturers, such as Bose, JBL, E-V and Altec to develop computer assisted design (CAD) programs just for this matter. In many cases they can be a big help. They can provide a great deal of information which is very difficult to obtain, and solve many problems quite adequately. Several of these programs have been described in these pages, and they are in widespread use.

They are not without their own prob-

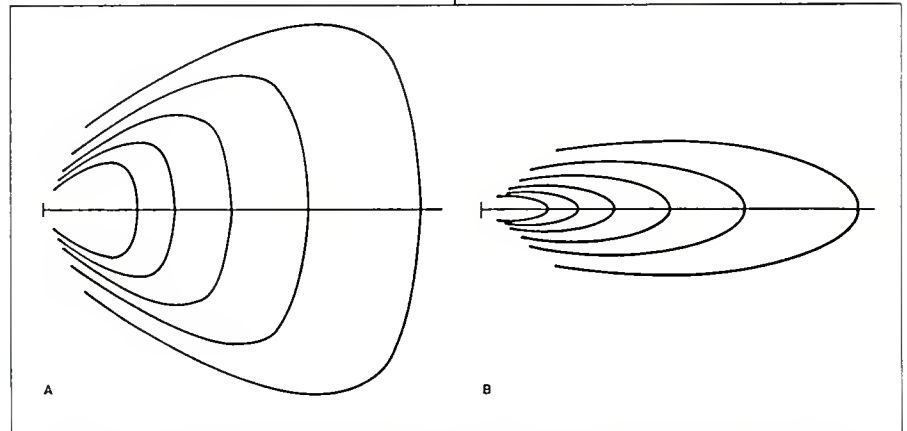

Figure 1. Dispersion overlays for a 90° x 40° horn. (A) horizontal, (B) vertical.

approaches to be of much help. Second, a loudspeaker's actual dispersion characteristics are far from obvious; even good published information (which is seldom available) is very hard to relate to a real situation. Third, even if a solution is found in one situation, it may not work very well in another.

In other words, coverage is difficult to understand. There is no good way to get a "feel" for it, seat-of-the-pants is just not enough. As a result, most sound people make a cursory effort to deal with the matter of coverage, without really knowing what they are doing, and console themselves that everyone is in the same boat.

Now there is more than one boat. If a problem is too complex for a person to deal with, a computer might be able to

lems, however. First, they can be expensive, especially if you don't already have the right personal computer. This expense is hard for many potential users to justify. Second, the program can be very clumsy and time-consuming to use, especially if the room involved has a complex shape. It is particularly clumsy when you need to use it in the field, and don't have your PC in your hip pocket.

Third, and most importantly, you don't really know how accurate it is. Exactly what process did the program go through to arrive at its answers? Was that really the best process? Did it take everything into account, or is there a possibility which was not considered? Just how accurate was the data that it used? It is interesting to note that

*Bob Thurmond is G.R. Thurmond and Associates—Consultants in Acoustics, located in Austin, Texas.*

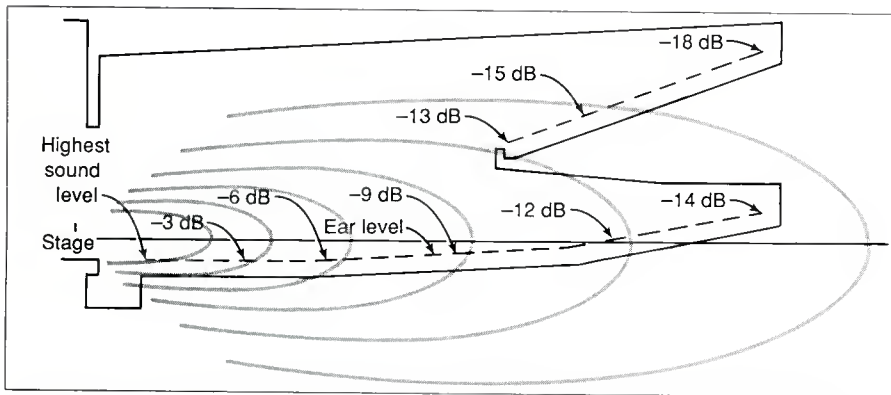

Figure 2. An overlay showing vertical dispersion for a typical horn application.

different programs can be given the same situation and come up with different answers. It is even more interesting to note that most consultants believe they can do a better design job than any of these programs. Ego? Or expertise?

### A BETTER WAY

There is yet another design aid which

It consists of transparent overlays which are placed directly over the drawings of the room to show immediately the coverage of a particular horn with a certain location and aiming. The overlay can be moved around to see what effects the corresponding movements of the horn would have on the coverage. Other overlays, representing other types of horns, can be tried to see

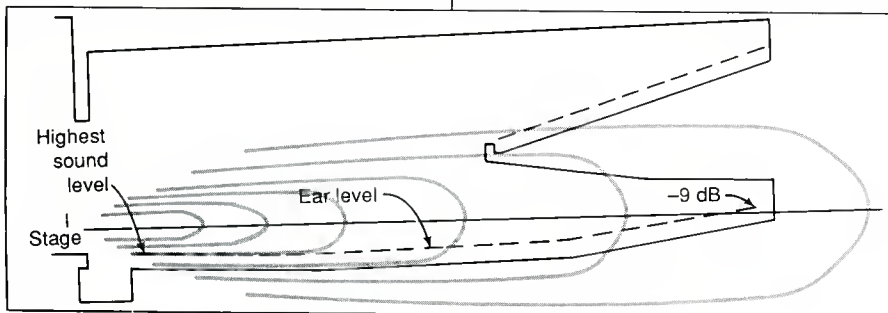
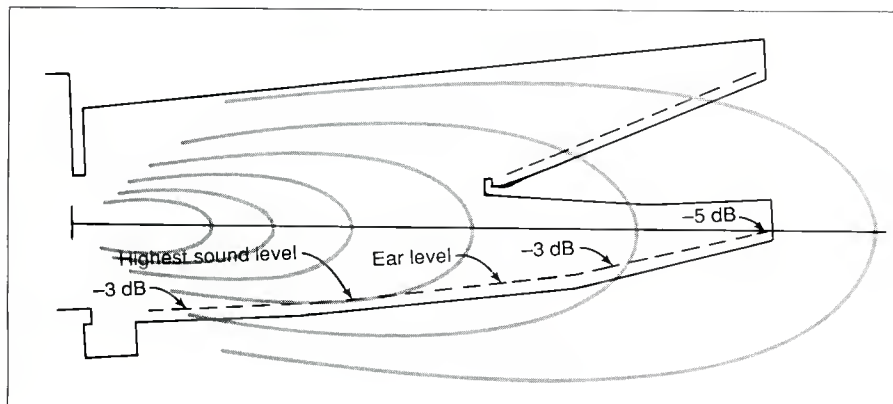

Figure 3. Improved coverage from a better choice of horn type.

may be of value to you. I developed it more than ten years ago, long before the first CAD, and still prefer it to any other approach. It is very inexpensive, easy to understand and use, and yields a surprising amount of accurate information quickly. In fact, many sound contractors have used it quite successfully for years.

which one works the best. A few minutes is all that it takes to select the best horn to cover a particular audience area and to know its proper positioning. A few minutes more will yield the practical extent of the coverage area and the evenness within it. Each additional horn requires a similar amount of time. A complete cluster

Figure 4. Still better coverage from a better horn location.



layout can often be accomplished in less time than it takes to enter the necessary room coordinates in a typical CAD program.

An example of this wonderful high-tech device is shown in Figure 1. Each contour line represents locations of equal sound level, or isobar, points. If you took such a horn outdoors, aimed it horizontally, and fed random noise over it, then took an A-weighting sound level meter out in front of the horn, took a reading, and found all the other locations where the level reading was the same, all these locations would fall on a line shaped like an isobar contour. If you then moved straight toward the horn until the sound level increased by 3 dB, you would find that your new location is 0.7 times as far from the horn as the old one was. Conversely, moving outward to increase your distance by a factor of 1.4 will reduce the level by 3 dB. This is exactly the interval between contour lines on each overlay. Since this ratio always holds true (well, almost) no matter what the actual distance, these overlays can be used with drawings of any scale.

### HOW IT WORKS

Since these are graphic devices, it is much easier to see how they work than to understand an explanation of it. Let us start with a section drawing of the proverbial typical auditorium, shown in Figure 2, and first examine the vertical coverage produced by a 90 by 40 degree horn. We place the overlay for this horn on the drawing, with the origin at the horn location and the axis line along the horn's center line. Let us first assume that the horn is about six feet above the stage floor and aimed straight out, an arrangement we have all seen more than once. We then compare the shape of the isobar contours with that of the seated ear level, which is dashed in about 4 feet above the floor. If these two curves line up closely, that means all the seats (front to rear, at least) will get nearly the same sound level. Such is not the case here!

The place where the sound level is the highest along the ear level line is where that line gets closest to the origin of the contours, in terms of the contour lines. In this case, that occurs at the front seat, which is just inside the first contour line. This also means that a point just inside the second contour line will have a sound level 3 dB lower than at the front seat, as indicated on our drawing. In the same way, we note that the level drops off 3 dB every time we

move out one contour interval. The rearmost seat is not quite one interval past the previous point, so the drop here is only about 2 dB.

When we total up all of the drop-offs, we find that the level at the rear is 14 dB lower than that at the front. Not very good! Furthermore, if we are expecting this arrangement to cover the balcony as well, the results will be even worse there.

If we measure the actual sound drop-off in a real room, it will not seem this bad. That is because at some point, called the critical distance, the direct sound level (which is what the overlays represent) has dropped until it is equal to the reverberant sound level, which is nearly constant throughout the room. Beyond the critical distance, the direct sound, which is vital to clarity and understanding, continues to drop off, until it is lost in the reverberant sound. At that point, sound quality is completely unsatisfactory, even though the (reverberant) level may still be adequate.

Is that what actually happens in our example? It is quite possible, considering the serious drop-off of direct sound from front to rear. An exact answer is more difficult to come by, but it can be done.<sup>1</sup> More to the point is the answer to this question: What can we do to minimize this problem?

### BETTER DESIGN

The obvious answer is to provide the same direct sound level to all seats. Not possible, you say. Maybe not, but we can come a lot closer than you might think. Let's see how.

Someone said, "Use a narrow-angle horn, like a 60 degree." Right idea, wrong choice. All the 90 and 60 degree horns of similar design have nearly identical 40 degree vertical coverage. Therefore, such a change will not help us, but using a really narrow-angle horn, a 40 by 20 degree, might.

Figure 3 shows the vertical coverage which results from substituting such a horn and aiming it at the rear row of seats. Experience shows that this aiming usually provides the best front-to-rear coverage. We see immediately that the dispersion contours closely follow the ear level contour in the front seats, indicating very even coverage. We further see that the level drops off only 9 dB from front to rear, a big improvement.

Who would use a long-throw horn in a typical auditorium? Actually, they have been used this way many times with

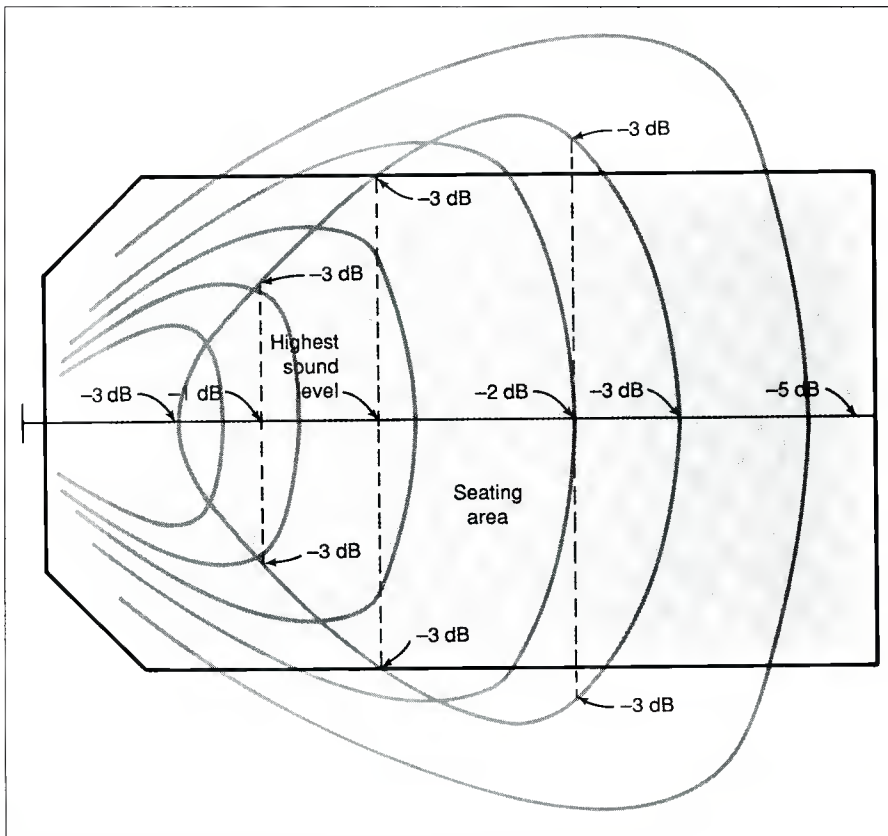

Figure 5. Horizontal dispersion and overall coverage contour.

great success, especially if two or three are placed side by side and angled about 40 degrees to each other. Such an arrangement will also deliver very high sound levels.

### TRY AND SEE

If you still would rather use a 90 or 60 degree horn, perhaps we can figure out a better configuration. If we slide the overlay around on the drawing, we can immediately see the effects of different locations and aimings on the coverage. This is much faster and more intuitive than trying various orientations one by one in a computer routine. Here, for example, we quickly see that locating

the horn about 20 feet above the stage, and aiming it at the rear seats, gains a significant further improvement in coverage evenness, as shown in Figure 4. Now the point of highest level is about 1/3 of the way back, with the level being only 5 dB lower at front and rear. Actually, the front seats are probably too far off the horn axis to get acceptable sound quality, but they may be so close to the stage that this doesn't matter.

Better coverage than this will almost certainly require multiple horns, to provide separate coverage for front and rear. The overlays can easily be

Figure 6. Vertical coverage in the balcony.

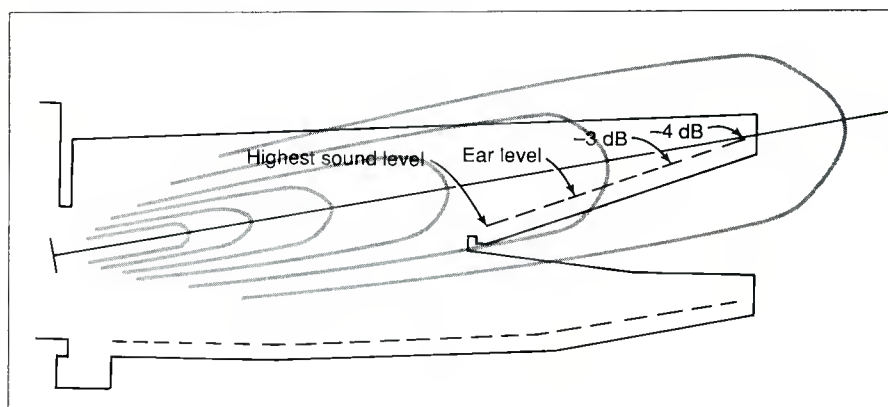

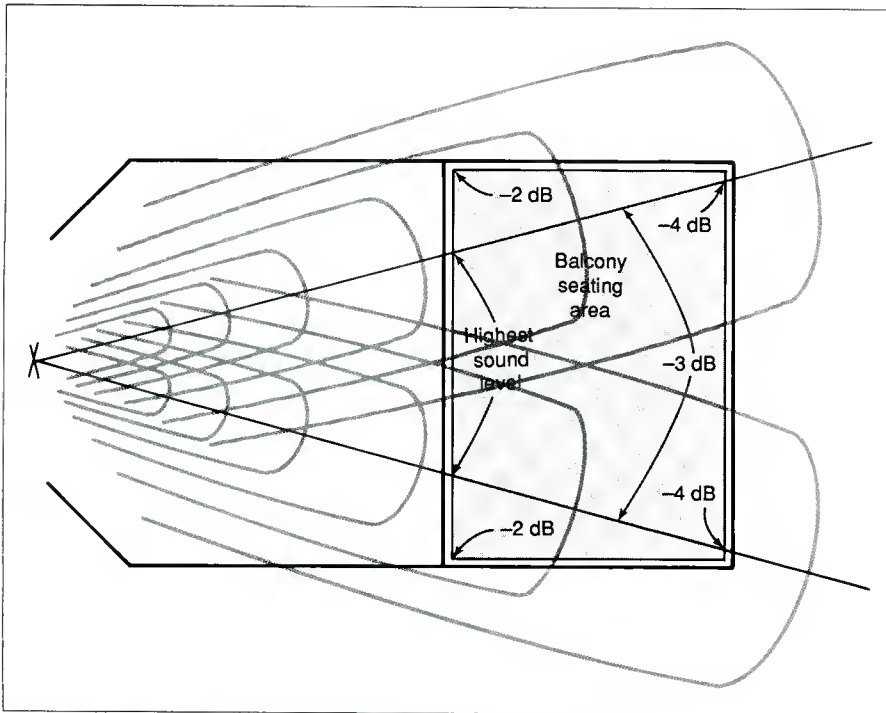

Figure 7. Overall coverage in the balcony from two horns.

used to do such layouts, but let us follow through on our basic example here. Assuming that this one horn is acceptable, let us figure out the horizontal coverage.

To do that, we note the locations of the points of highest level,  $-3$  dB,  $-6$  dB, etc., and transfer them to the center line of the room plan, as shown in Figure 5. We draw transverse lines through these points, then place the horizontal dispersion overlay, for the horn we want to try, in the proper place, as shown. Now the isobar contours show how the levels drop off as we move from the center line to either side. For example, one interval to either side of the highest level point indicates a  $-3$  dB point. Similarly, 2 dB either side of a  $-1$  dB point on the center line also designates a  $-3$  dB point. After a number of such points are located, they can be roughly connected to indicate the  $-3$  dB contour line, as shown. Other contour lines can be drawn similarly in just a few minutes, but this one already tells us that the front corners of the seating area will not be covered by this horn. A more complex arrangement will be needed, probably involving smaller front-fill units aimed toward the sides. As a further example, let's see how we might cover the balcony. A quick check with a  $40$  degree vertical overlay shows that such a dispersion does not reach well into the balcony at all. Furthermore,

such a horn will put as much sound into the floor seats as the balcony, a flaw which is overlooked by some CAD routines! Clearly, a narrow-angle horn is needed here.

Figure 6 shows the performance of such a horn. Drop-off from front to rear is  $4$  dB, which is probably acceptable, and there is negligible spillage onto the floor. So, we again transfer the various signal-level points to the plan drawing, to check horizontal coverage.

Right away we see that a single  $40$  by  $20$  degree horn is much too narrow to cover the width of the balcony. Since all wider-angle horns also have vertical dispersion which is too broad, we must use two  $40$  by  $20$  degree horns side by side. By the way, detailed measurements indicate that a side-by-side arrangement, with drivers touching, gives much smoother coverage than that where the horns are stacked at their mouths and splayed.<sup>2</sup>

What angle provides the smoothest overlap from one horn to the next? The answer is difficult, because it is not the same for high frequencies and low, even in the same horn. Generally, overlapping where each horn is  $3$  dB down produces the smoothest transition, but spreading them more so that they overlap at the  $-6$  dB line causes only some raggedness at higher frequencies. This may become a case-by-case judgement decision.

In this case, overlapping at  $-3$  dB easily covers the full width of the balcony, so this is the best choice. Figure 7 shows this arrangement with several vertical level readings transferred from Figure 6 and located on each horn axis. Between these axes, the coverage will be very uniform, and will drop off outside the axes exactly as before. Thus, we see that the overall side-to-side coverage will be more uniform than the front-to-rear. In fact, the indicated drop-off assumes no reflections off the walls; in reality, such reflections will probably improve the situation even more.

In both the balcony and floor seating areas, coverage at the rear would be improved if the horns were located somewhat higher. In this case, as in many, the best location is revealed by the overlays to be just above the proscenium opening. This is a major reason why permanent clusters are often best located there, but until now it was difficult to verify this.

It is clear that this overlay technique can tell us all we need to know about audience coverage. That alone is worthwhile, but it also works quickly and easily that we can try many design alternatives and see immediately which is best. No longer do we have to guess at audience coverage, or just cross our fingers.

This overlay technique also works well in more difficult situations, such as arenas. It gets a bit tricky when there are odd seating slopes or extreme horn aiming angles, but even these can be accommodated. Such advanced techniques are beyond the scope of this article, but they are really only extensions of these basics. Also, there are other matters, such as figuring driver power levels, which can be done with this technique. The author is willing to supply more information to anyone who is seriously interested. In such a case, you may contact him directly at 512-453-4173.

<sup>1</sup>G.R. Thurmond, "Cluster Suitability Predictions Simplified," presented at the 81st Convention of the Audio Engineering Society (Preprint No. 2388) November 1986.

<sup>2</sup>G.R. Thurmond, "Measured Performance of Loudspeaker Combinations," presented at the 58th Convention of the Audio Engineering Society (Preprint No. 1284) November 1977. [BB](#)



# Frog to Prince: RCA to BMG

*Is there really a way to make a great studio greater? Can the right choice of equipment and designs improve a studio that already has incorporated some of the most innovative concepts in the history of recording? Is there a way to bond the old world of audio with the new?*

**C**an the right person answer the questions above? The final question was answered by the Bertelsmann Music Group, who, on December 15, 1986, acquired RCA's entire recording studio complex.

## BMG CHOOSES DON FREY

The BMG-owned (formerly RCA) recording studios, the largest facility in New York City, has completed the first phase of a major renovation. The key to such a renovation lies in a hierarchy of command that can organize every aspect from conceptual designs to fundamental principles of acoustics and engineering. The person in charge of this new construction is widely respected industry executive and studio consultant, Don Frey. Don was partnered for twenty-five years with Phil Ramone in A&R recording studios where he personally engineered sessions for Ray Charles, Nina Simone, Ike and Tina Turner, and many others. Having mixed thousands of TV commercial sessions, Don is quite the Renaissance man of recording and his experience, which spans nearly half a century, qualifies him beyond the shadow of a doubt.

My first hour with Don and his press agent Howard Sherman was spent touring the studios and production rooms. As we explored, we walked down corridors lined with the gold and platinum records of more artists than can be comfortably mentioned in this story. The facility's historic pedigree runs the gamut from *Billy Joel* to *Vladimir Horowitz*, *Ella Fitzgerald* and *The Jefferson Airplane*. Our concentration was on studio C where the renovation has been taking place, however, it is hard to ignore the awesome history

that one can sense upon walking down the hallway where all the mastering and restoration of old masters takes place.

---

**Every room is equipped with a completely different kind of reference monitor speaker.**

---

wide open and the music blasting, the sound from all of these rooms mixing in the hallways. Don shows me room after room, each manned by an engineer who's job is to complete one specific project at a time. Don explains, "...and this room is special projects. This is the original RCA vault containing so many historic masters. People come right here and lease from the vault, and they sell ideas to users...just to give you an example, Shell Oil bought a whole series of masters for their tank-truck

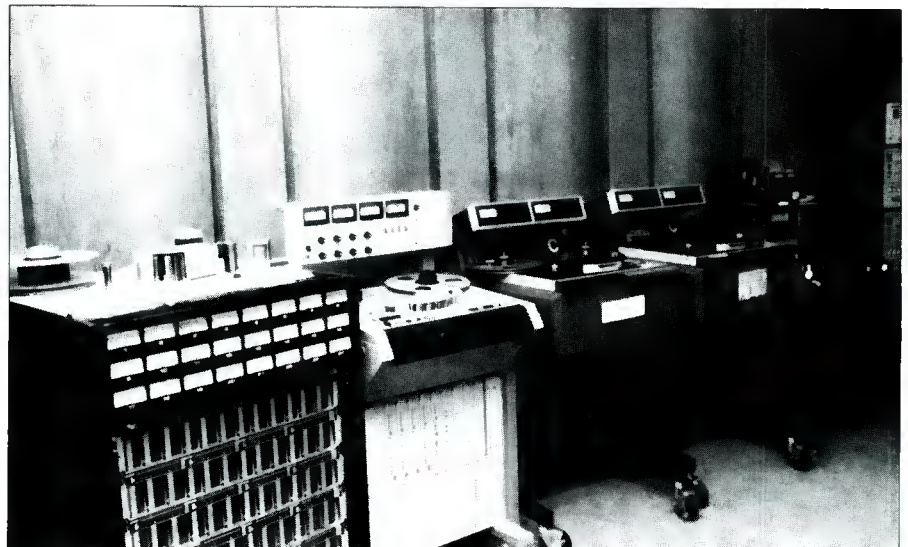

*Figure 1. Tape machines are lined up at the rear of Studio C's control room. Everything is on wheels and other recorders can be brought in.*

## EXPLORING "THE VAULT"

As we approach the *corridor of mastering*, we can hear the sound of many types of music from classical to rock to jazz to country to show music to...you name it, all playing at once. Since there is no true air-recording to be done in any of these rooms, there is no concern for isolation. As a matter of fact, almost every room that we visit has the door

drivers. You come in and load up your truck with Shell Oil and you're handed a cassette of country western music. There are many other major product manufacturers buying these special projects."

So this floor is all mastering? "That's all this corridor is...well, mastering and what we call restoration-re-issuing, for CD, and hopefully in the next couple of

years for R-DAT, all of the old masters. Red Seal is very active in this and of course the Presley stuff and the Perry Como stuff and Sam Cooke and it just goes on and on...it's amazing what you hear in these hallways."

Every room is equipped with a completely different kind of reference monitor speaker. Could you explain

---

**The feeling is similar to entering an elegant airplane hangar.**

---

why? "This idea really started in the live recording sectors. You had what was called *guest mixers*. The same holds true today. If any one of these people move to a different room, their monitor speakers move with them. For this kind of work situation there is no need for speakers in the ceiling. There's no need to acoustically tune the room or put in notch fil-

---

**...and they covered everything with red carpeting...They did all of their albums here.**

---

Do you really like those speakers? The gentleman replies, "They're good working speakers. There are no highs in this music that I'm listening to. If you hear any highs on these you've got trouble."

Don Frey adds, "In fact the element of the 604s is the one that's used in the UREI 813s. The basis of the UREI 813 is a 604 co-ax speaker element. UREI took that basic element and expanded on it. The Big Reds came somewhere in-between." Our brief tour down mastering lane is complete.

**A ROOM THAT MOVES?**

Don takes me through many doors, one elevator ride, more doors, one

was responsible for the implementation of Dr. Olsen's concepts. It was John Volkmann who determined the number and size of the polys that were to be used at the original RCA complex. The polys are still the fundamental elements that give these studios such acoustic integrity. Even some of the control rooms utilize the poly as an acoustic-design building block. The studio ceiling moves. Those huge ceiling panels, lights and all, can move up and down, changing the characteristics of the room to suit any given project and taste. That part of the ceiling back there (he points to the far end of the room) not only moves down, but tilts so that the back edge comes to the top of the partitions and the front edge stays where it is. The wall panels (polys) are on special casters so that they can come out from the walls to form gobo-like enclosures. Behind each of these wall panels are drapes that can be used to acoustically balance the ambiances and isolation as needed. This (studio A) is three floors in height from the floor to ceiling. The three studios, A, B and C, are right on top of one another. Each studio is three floors in height, on the fourth, seventh and tenth floor. This studio (A) can comfortably seat two hundred to two hundred and fifty musicians."

We step into the control room and inspect, "This is an MCI 600 console. The Sony 3324 goes wherever it is needed." Is the digital format becoming the preference for acoustic/orchestral recording? "Yes. It is." Do you have any clues as to why this is so? "I think *their* thinking is that when the filter problems and the D/A and A/D converting in conjunction with those filters is straightened out, what's on the tape is going to be better than what we're getting now."

We enter another hallway and I notice all sorts of recording equipment being moved all about. What's going on Don? "They're putting all the old equipment into a big room so that it can be inventoried for sale. There's tons of equipment that is being sold in order to make room for the new. Of course not all the old stuff is on sale." There's a lot of good stuff here...8068, 8058 consoles, Ampex machines...one could entirely outfit a few studios. Does the public know about this? "They will, there will be all kinds of ads and fliers..." Hmmm Scully, I'd like that...maybe a few of those Pultecs or some Neve EQs or how about these...



Figure 2. Studio C control with its view into the studio.

ters. This is a near-field work condition. This next room is a mix room equipped with Neve and Necam... Red Seal during the day and jazz at night. Toscanini is in here for the next two months, during the day."

The last room in the corridor contains a wall of equipment, a pair of Altec 604Ds, and a gentleman sitting comfortably, listening.

huge heavy double door and *voila*...studio A. The feeling is similar to entering an elegant airplane hangar. Don tells me, "All of this curvilinear design work was conceptualized by Dr. Olsen, an acoustician who taught at Princeton. He called those curved shapes *polys*. You will probably notice that the polys are a recurring concept in this complex. Mr. John Volkmann



Figure 3. Studio A. Our wide-angle view clearly shows a number of the polys. The ceiling can be moved up or down, according to the exact acoustics needed.

## DON KEEPS THE ROOMS BOOKED

"...and they covered everything with red carpeting." Don is describing another studio within the RCA complex that belonged to *The Guess Who* (Studio D). "They did all of their albums here." It was a common occurrence in the 60s and early 70s for a successful band to have an entire studio of their own. At times there was little to no attention paid to acoustics other than to completely deaden the room (*i.e.* red carpet everywhere). As we speak, a crew of men come in and begin to remove the sixteen-bus Neve console that is here, in the old Guess Who studio, for the sale's inventory.

"As strange as the room is, I booked this studio for one year, starting January 4, 1988, eight hours a day, five days a week. It's booked to a group that does all the pre-scoring for one of those kids' half-hour animated features called *Thundercats*. Another console and a long list of outboard equipment is coming in for them. For this animated project, they'll be using analog recorders and a compliment of Dolby noise reduction."

After more treks through corridors and another elevator ride, we come to Studio C, the site of the renovation. The studio is a whopping fifty feet wide by seventy-five feet long by thirty feet high. This studio is another Olsen/Volkman design with a tremendous emphasis on controllable, ambient acoustics.

"The renovation called for a total re-wiring with Monster Cable. We also put in two new isolation rooms. The dual isolation rooms are sixteen by twenty-four feet. In October, the renovation work was suspended in order to fulfill a commitment to film director Spike Lee. The soundtrack for his upcoming *School Daze* feature was done here in studio C. Studio C was one of the only rooms in New York large enough to accommodate an eighty-five piece orchestra."

---

### Everything in the control room has been fastidiously chosen.

---

"The composer (Spike's father, Bill Lee) conducted eighty-five musicians to picture, a rare procedure for a New York film project. Normally they take counts, for instance, this scene is three minutes and five seconds long etc., and they'll know on a *count* where the door closes or where the knife jabs through the curtain. This count method is much easier to conduct. Coordinating the start of eighty-five musicians is quite a task. There were no headsets, no click tracks, and all done to picture."

What's behind these wooden poly walls? Don pulls out one of the hinged sections and shows me. "Basically that is the outside wall of the building with varying degrees of rigid insulation. Those spots where you see dark holes,

are negative traps with insulation in the back but none on the front. Up there is the big screen (28 feet) and the projector."

Is this room going to continue accommodating pop and rock projects? "Rock and Roll, Madison Avenue (post-production), voice-overs, scoring of all kinds...any project that requires superlative acoustics and available *live* space will continue to book these studios. This room, like studio A, is tunable and exceptionally flexible in meeting virtually any acoustic needs. The isolation rooms serve as a studio within a studio, adding further to this studio's ability to accommodate all sorts of projects."

## THE PLACE FOR NF MONITORING

We step into the control room and Don tells me, "Everything in the control room has been fastidiously chosen. After over forty years of audio experience, I certainly know what not to do. The reason for choosing the B&W speakers as the monitors for the last session was to match the B&W speakers that are down in studio A. We have innovated our own version of the near-field monitoring concepts. The philosophy behind this concept is based on what we have observed in the industry. We have noticed that many clients have a monitor that they are particularly fond of. Rather than impose a monitor on them, we have decided to give all our clients a choice of monitors. If they wish, they can even

bring their own. To top that, we've added a very unique feature to a control room monitor system in this studio. We're giving the guest engineers that come in a choice of four power amps. Bring your own speakers or utilize the selection that we have. Once the speakers are chosen, the producer/engineer can select from McIntosh 2500, Bryston, Hafler and Krell. While this renovation takes place, bi-amplified/modified Big Reds (monitor speakers) are filling the gap for projects that come through with old-time engineers who were familiar with that speaker system."

"The reason for the Sony 3000 console is that it is the quietist analog console on the market today. We measured them all and we tried them all. The reason why we went for a console that is quiet as opposed to all the whistles and bells that we get with the Neve V series and the SSL is that this room is primarily a tracking room. We want live acoustic recording and that is the kind of recording that will be here. Whether it's analog or digital recording, our priority is QUIET."

To what do you attribute the quietness of the 3000? "The basic design utilizes fewer amplifiers in its front-to-back configuration. The headroom within the console never changes. We've measured it at around 28dB from section to section. There are no transformers anywhere in the signal path. When the equalizers (in the console) are bypassed they are truly and electronically removed from the circuit...not an amplifier that replaces the equalizer. All of these things tend to subtract from the inherent noise of a basic console. Automation shows up at the screen along with other VCRs for production work. The 3000 console is a clone, in the sense of performance, of the 3324 tape machine...virtually no tweaking has been necessary. The original 3M digital required an engineer to stay with the machine on every session. The Sony 3324s that were installed here some time ago have not needed any serious tweaking since they were installed."

Do you anticipate any major changes in C's control room design? "We have been using a strictly near-field approach to monitoring. There are no soffits and there won't be any in here. The discovery that we have made is that the clients have acquired specific

---

**Technology's goal has been to reduce the number of accidents and advocate a more deliberate approach with less room for error.**

---

tastes which can be best met by accommodating many different types of monitors. Although this room is Dr. Olsen's poly design, the acoustics needed to create an absolutely accurate listening space are actually unnecessary. Dr. Olsen designed this control room for sound, not a specific pair of speakers. There is a low-end diffuser in front of the console but, the relationship between the listening space and the speakers is far less critical when near-field monitoring techniques are employed. This room has already proven to be a reflection-free listening room, free from unwanted resonances. Typically, near field monitoring frees the listener from what a room might impose upon the sound. We will soon be adding large monitors to this room, they will probably be UREI 813s or of the like. The big monitors will be used for that end-of-the-day listen when there is a desire to sit back and crank the music for the feeling of it. Many still like the high SPL and we certainly don't want to deny them that sensation.

---

**Typically, near field monitoring frees the listener from what a room might impose upon the sound.**

---

**THE PERPETUATION OF CREATIVE RECORDING**

At a time when the trend is to shrink a space and then try to recreate that space with outboards, BMG-owned Studios is making the most out of their vast available space. The advantages to those who are in the know can be limitless. Harnessing acoustic phenomena is an area that has yet to be fully explored. Electronic secrets are the worlds most fleeting. However, the technology behind the loudspeaker is relatively unchanging.

Why is it that the final link to our ears, the loudspeaker, has changed so little? Don sheds some light on this age old dilemma, "Perhaps the loudspeaker is a reminder that we have roots...a point of reference. There are many instances throughout the history of recording where a magnificent sound was discovered by accident. Technology's goal has been to reduce the number of accidents and advocate a more deliberate approach with less room for error. Here, at RCA, both worlds meet and shake hands. The denial of history is as much of a mistake as the fear of future technology." 

**EQUIPMENT LIST FOR STUDIO C**

- Sony 3000 console
- Sony 3324 digital tape machine
- Sony 2-track digital tape machine
- Sony VPH-1040Q 600 Lumen projector in studio w/RCA 25-inch monitors
- Mitsubishi 2-track digital tape machine
- 6 EMT stereo plates with remotes
- Lexicon 224 LARC digital reverb
- AKG ADR 68K digital reverb
- McIntosh 2500 power amps
- Bryston power amps
- Duntech or Yamaha NS-10 speakers
- Pultecs
- Drawmer and Kepex noise gates
- Drawmer compressor/expander LA-2A, LA-3A and 1176 compressors
- Neve 4-band equalizers
- Neve compressor/limiters
- Monster Cable for jack bay, mic cables, headsets and speakers
- Orban parametric equalizers
- Complete TimeLine "Lynx" SMPTE lock-up system for 24-track analog or digital tape w/JVC VCR (U-matic) video play back
- Vintage tube mics: Neumann U-67, M-49, M-50c, M-250, U-47 and more.



# Hands On

## FOSTEX 460 RECORDER/MIXER



● The Fostex 460 is the company's top-of-the-line recorder/mixer. It includes a 4-track cassette recorder built into a complete 8-input mixer.

Packed with sophisticated features, the 460 offers much of the flexibility of a professional recording studio. Yet it is surprisingly easy to operate, considering how many controls it has. This is due to the well-organized layout. I completed a multi-track recording, overdubs, and mixdown in an hour.

The 460 even has SMPTE/EBU sync capability! You can lock it to a video recorder, which is strange and amazing to see in a cassette recorder. Other audio cassette recorders have trouble synchronizing with video recorders because of tach rate irregularities.

People working with film or video soundtracks can do their preliminary work with this machine, and distribute the results on cassette. MIDI composers will appreciate the 460's ability to record a sync tone to trigger MIDI instruments and mix them live to stereo. The recorded sound quality is more than adequate to make high-qu-

ality demo tapes to send to record companies, or even to create the basis of a full-blown studio production.

The 460's appearance is high-tech, handsome, and well-crafted. Although it's low-profile and compact, it has a wide range of features:

- 8 balanced mic inputs with switchable phantom power on each input.
- 8 unbalanced phono jack line inputs; 8 unbalanced 1/4-inch phone jack line inputs.
- Input-level trim.
- Ability to record on any track or any combination of tracks.
- 2 aux buses (one with panning).
- 3-band sweepable equalization.
- Solo for each input.
- Complete monitor mixer with panning.
- Auto return.
- Dolby B or C noise reduction.
- Two tape speeds.
- Pitch control.
- Two headphone jacks.
- Remote punch-in/out.

- Remote play/locate 1.
- 4 direct outs.
- Access in and out for each input.
- Digital tape counter.
- -10 dBV nominal output level.

The Fostex 460 retails for \$2495.

### INPUT-MODULE FEATURES

At the rear of each input module is a balanced, 3-pin pro' audio connector for a microphone or direct box, and an unbalanced 1/4-inch phone jack for line-level signals from a synthesizer, drum machine, electric guitar, etc. You can plug directly into one of these jacks for direct-injection recording. Other features are described below:

- Fader. This is used during recording to set recording levels, and during mixdown also to adjust the balance among tracks. The action is not as smooth as that of a studio mixing console, but its operation is noise-free.
- INPUT TRIM pot. This adjusts the pre-amplifier gain to accommodate a wide range of input levels, from -60 dB to -20 dB.

- **Input selector switch.** With this switch, you select the source you want to work with: input, line, or off. "Input" is a microphone or line-level signal. "Line" can be any line-level signal, but usually is the signal from the tape tracks on input modules 5-8. That's because four jumper cables are normally inserted between Tape-out jacks 1-4 and Line-in jacks 5-8. The center-off position can be used to mute tracks during mixdown.

- **ASSIGN switch.** In conjunction with the pan pot, this switch is used to assign (route or send) the input signal to the desired tape track.

- **PAN pot.** During recording, the PAN pot is used along with the ASSIGN switch to assign each input to the desired track. If you rotate the PAN pot full left, the input signal goes to track 1 or 3. If you rotate it full right, the signal goes to track 2 or 4. You also can set up stereo submixes. During mixdown, the PAN pot is used to place the phantom image of each track wherever desired between the pair of playback speakers—left, center, right, or anywhere between.

- **AUX 1 send control.** This adjusts the amount of signal sent to the AUX 1 bus, which is normally connected to the input of an external effects device.

- **AUX 2 send control.** This adjusts the amount of signal sent to the AUX 2 bus, which is normally used as a monitor mix bus. A pre/post/line switch lets you send the AUX 2 signal pre-fader and EQ, or post-fader and EQ. The "line" position accepts a line signal (usually from the tape) into the AUX 2 bus, say for monitor mixing.

- **3-band sweepable EQ.** This highly flexible equalizer offers 15 dB of shelving EQ at 10 kHz, 15 dB of peaking EQ at 400 to 6000 Hz, and 15 dB of peaking EQ at 60 to 1000 Hz. The Owner's Manual includes an excellent section on equalizer usage.

- **SOLO.** When you press the SOLO button in a particular input module, you monitor only that input. The button is a locking, push-push type. More than one input can be soloed at a time.

- **PEAK/SOLO indicator.** If the input level is so high as to cause distortion in the input preamplifier, the peak indicator flashes, warning you to reduce the INPUT TRIM setting. The same indicator lights up when the SOLO button is pressed—a necessary function, making it easy to tell at a glance whether you're in the SOLO monitoring mode.

## OUTPUT-MODULE CONTROLS

The output module includes four MASTER faders to control the overall level of each bus feeding the tape tracks. These faders are arranged close together for easy adjustment as a group.

---

**If the input level is so high as to cause distortion in the input preamplifier, the peak indicator flashes, warning you to reduce the input trim setting.**

---

Also included are four gain pots and pan pots for the bus signals sent to the Stereo Out jack, and a master gain control for the stereo mix bus.

If you prefer to mixdown to buses 1 and 2, you use the four bus master faders. If you prefer to mixdown to the stereo mix bus, you use the four gain and pan controls instead. If you monitor the stereo mix bus, the gain and pan controls also can be used for a monitor mix of the four buses.

Following each bus is an LED bargraph level indicator. A METER select switch lets you meter either BUS (the mixer output), TAPE (the tape-deck output), or STEREO (the stereo mixdown bus).

Although there are four BUS-in jacks which could be used for AUX returns, the 460 has no bus-in level controls. Instead, you set the overall aux level by the aux-send controls in the input modules. You can use input modules for AUX returns if desired.

## MONITOR-SECTION CONTROLS

The monitor section is very flexible. The MONITOR SELECT switches let you choose what you want to listen to: Tape or bus (1-4), Aux 1 or 2, 2-channel mastering recorder, or stereo mix bus. If you monitor the stereo mix bus, you can control the level and panning of each bus or tape track.

If you monitor channels 1 and 2 simultaneously, you hear channel 1 panned left and channel 2 panned right for stereo monitoring. The same arrangement is used for channels 3 and 4. If you monitor only one channel, it is heard in mono centered between your monitor speakers or headphones.

Three pots are provided for independent overall level control of solo, monitor, and headphones.

## CASSETTE-RECORDER FEATURES

- **Noise-reduction switch.** Located on the back of the unit, this switch lets you choose Dolby B, Dolby C, or off. Normally you'd use Dolby C during recording and mixdown for maximum reduction of tape noise. You set the switch to Dolby C, B, or off to match the encoding of recorded tapes.

- **Speed switch.** Usually, you set this switch to "high" (3 3/4 in./sec.) for maximum high-frequency headroom and minimum wow & flutter. You set it to "low" (1 7/8 in./sec.) to play recorded tapes.

At low speed, track 4 is dedicated to sync signals, noise reduction is cancelled on track 4 only, and you cannot record on track 3—it is a guard band.

Unlike other cassette recorder/mixers, the 460 is the first to have two sets of record EQ for the two tape speeds. This provides flatter record/playback response at slow speed.

- **PITCH control.** This allows ±15% pitch variation of the tape deck to match the tuning of recorded tracks to non-tunable instruments being added.

- **RESET 0.** This button resets the digital tape counter to 0000.

- **MEMORY 1, MEMORY 2.** You push these buttons to mark the beginning and end of a section you're going to punch in.

- **AUTO RTN 1-2.** If you press this button and hit PLAY, the tape rewinds automatically when MEMORY 2 is reached and stops at MEMORY 1. This is useful for repeated practices of overdubs and mixdowns—a really convenient feature.

- **LOCATE 0.** Pressing this button makes the tape shuttle rapidly to the 0 point on the tape, then stop. It facilitates finding the top of the tune you're working on.

- **LOCATE 1.** With this button, the deck shuttles to the MEMORY 1 point on the tape, then stops. Typically, the MEMORY 1 point is the beginning of an overdubbed section.

- **AUTO PLAY.** When this button is pressed, the deck will go automatically into play mode after it returns to zero.

- **RECORD TRACK.** These four buttons select which track(s) you're recording on. Each button has an as-

sociated LED that blinks when the button is pressed, warning you that the track will be erased if you go into record mode.

The tape deck is biased for high-bias (chrome) tape such as Maxell XL-II, TDK SA-X, or equivalent.

The tape transport uses a single DC motor with servo speed control. In the deck are one ferrite erase head and one permalloy record/playback head. Fast-wind time is 100 seconds  $\pm 10\%$  for a C-60 cassette.

## MISCELLANEOUS

Most of the connectors are RCA phono jacks. There's a pair for the 2-track stereo bus labeled STEREO OUT, two 2CH IN jacks for an external 2-track mastering recorder, four bus outs and four bus ins, AUX 1 mono OUT, and AUX 2 stereo out. AUX 1 IN and AUX 2 IN are not auxiliary returns; they are line-level inputs to the AUX buses.

On the front panel are two 1/4-inch headphone jacks, a 1/4-inch jack for a PUNCH IN/OUT footswitch, and a 1/4-inch jack for a PLAY/LOCATE 1 footswitch. They are not labeled in white, which makes them hard to read. The same is true for the pitch control.

The unit is powered by a special external supply which includes the power on-off switch. Putting the power supply outside the main unit reduces size, weight, and hum.

The Owner's Manual is clear and concise, with a conversational tone and helpful diagrams. Beginners, however, would need to study introductory books on multi-track recording before they could understand the manual or use the 460. The manual includes such extras as a blank track sheet, a system block diagram, a section on live reinforcement, and a section on troubleshooting.

## PUBLISHED SPECIFICATIONS

These cassette-recorder specifications are followed by my evaluation:

Record/play frequency response: 40Hz–18 kHz  $\pm 3$ dB. This is excellent for a cassette deck. The tonal balance of the recorded signal should sound very much like that of the input signal.

Signal-to-noise ratio: 57 dB weighted without noise reduction, and 70 dB weighted with Dolby C. This is excellent for a cassette deck. Hiss should be nearly inaudible on each track. With any mixer, however, noise increases 3

dB when the number of tracks mixed together is doubled.

The signal-to-noise ratio of a single mic input is 66 dB weighted, which is very good but not excellent. You might hear a little mixer hiss when using a microphone of low sensitivity picking up a quiet sound source at a distance. This rarely occurs in home-recording situations, so it should be no problem.

Wow & Flutter:  $\pm 0.1\%$  IEC/ANSI weighted. This spec is very good, but not quite as good as that of high-quality open-reel recorders. The reproduced pitch of instruments should sound steady most of the time.

## OPERATION

Let's go over the procedures for each stage of a recording session with the 460. We'll assume that the power is already switched on, and you've selected fast tape speed and Dolby C noise reduction.

First, be sure that four of the included jumper cables are connected between Tape out 1-4 and Line in 5-8. It's confusing at first to tell where to make these connections: Tape outs 1-4 are not given number designations, and these jacks are located near input modules 5-8. You'll have to refer to the diagram in the manual. Normally these jumpers are always left in place.

In this example, we'll record a stereo mix of the rhythm instruments on tracks 1 and 2. Note that there are many ways to achieve various functions with the 460; the procedure below is just one.

### Recording

1. Plug in headphones or a power amplifier and speakers.
2. Plug in microphones and/or electric instruments.
3. For each input in use, turn on phantom power if necessary.
4. Set all INPUT selectors to INPUT.
5. Set all ASSIGN switches to 1-2 and use the PAN controls to assign each input to track 1, 2, or both (for stereo panning).
6. Set the TAPE/BUS selector and METER selector to BUS.
7. Turn up the PHONES level and/or the MONITOR level.
8. Press TAPE/BUS 1 and 2 to monitor Bus 1 and 2.
9. Set bus master faders 1 and 2 to "0."

10. While the musician is playing, set the TRIM control so that the PEAK LED flashes only on the loudest passages.

11. Using the input fader, set the recording level so that several red LEDs light on the bargraph meter. Although the Owner's Manual states that the fader setting should normally be around  $-5$  to  $+5$ , I found the required setting to be around  $-22$ .

12. Set EQ as desired, or just leave it flat. You may need to re-adjust the recording level after setting EQ.

13. Insert a blank cassette, and reset the tape counter to "0000."

14. Using the RECORD TRACK buttons, select the track(s) you want to record on (in this case, tracks 1 and 2). Their corresponding LEDs will blink, indicating record-ready status.

15. Press the RECORD and PLAY buttons to start recording.

16. Press STOP at the end of the recording.

### Playback

1. Release the RECORD TRACK buttons to prevent accidentally erasing the tracks.

2. Hit the LOCATE 0 button to rewind the tape to the beginning of the tune. It will stop automatically at the "0000" point on the tape counter.

3. Set the METER selector and TAPE/BUS selector to TAPE.

4. Press the PLAY button.

### Overdubbing

(In this example, input module 1 will be used for the live instrument to be overdubbed.)

1. In Input 1, plug in the cable for the voice or instrument you're going to overdub. Set the INPUT selector for that channel to INPUT.

2. Shuttle the tape to the point just before where you want to overdub.

3. Press the MEMORY 1 button to indicate the starting point for the overdub.

4. Using the PAN pot and ASSIGN switch, assign the new instrument to be overdubbed to the desired open track.

5. Set the bus master fader for that track to "0."

6. Set the METER switch to BUS.

7. Set the BUS/TAPE switch to BUS.

8. Set the AUX 2 input selectors for channels 5-8 to LINE. Those AUX 2 sends will adjust the levels of the tape signals in the monitor mix.

9. Set the AUX 2 input selector for channel 1 to PRE. That AUX 2 send will adjust the level of the live signal in the monitor mix.

10. Set the MONITOR selector to AUX 2 to hear the monitor mix.

11. Have the musician play. Set the INPUT TRIM control so that the PEAK-LED flashes only on the loudest passages.

12. Using the fader, set the recording level so that several red LEDs light on the loudest passages.

13. Press the PLAY button.

14. Using the AUX 2 sends as a monitor mixer, set up a headphone mix of the recorded tape tracks and the live signal being recorded. The monitor level of the live signal (module 1) is set by its AUX 2 send control set to PRE; the monitor level of the tape tracks (modules 5-8) are set by their AUX 2 send controls set to LINE.

14. (Alternative method). Press the RECORD TRACK selector for the track you want to record. The blinking LED will indicate record-ready status.

Press the RECORD button once to hear just the input signal being overdubbed (for rehearsal). Press it again to hear the tape signal mixed in.

15. Press the LOCATE 1 button to rewind the tape to just before the point where you want to start overdubbing (the MEMORY 1 point).

16. When you're ready to record the overdub, press the RECORD TRACK button for the track you want to record on.

17. Press PLAY and RECORD simultaneously. The recording LED will light.

18. Hit STOP when the overdub is done.

19. To play the overdub, release the RECORD TRACK selectors, press LOCATE 0, select TAPE on the MONITOR and METER selectors, and press PLAY.

20. You can set a quick mix with the AUX 2 controls for input modules 5-8 (all set to "line.")

### Bouncing tracks

Here's an example of how to bounce or ping-pong tracks 1, 2, and 3 to track 4:

1. Monitor BUS 4.

2. Meter BUS.

3. Set the BUS 4 master fader to 0.

4. Set Inputs 5, 6, and 7 to LINE (for a tape input).

5. Assign Inputs 5, 6, and 7 to BUS 4.

6. Press PLAY.

7. Set faders 5, 6, and 7 for the desired mix.

8. Set EQ for inputs 5, 6, and 7

9. Press the RECORD TRACK 4 button and record on track 4.

10. When the song is done, your bounce is complete. The mix of tracks 1, 2, and 3 is now on track 4. After re-winding to the beginning, you can record new material on tracks 1, 2, and 3.

---

**I also recorded some compact discs and compared the playback to the source. They were remarkably similar.**

---

### Mixdown

1. Connect the STEREO OUT jacks to the input of a 2-track recorder (open-reel or cassette). Alternatively, connect Bus 1 and 2 out to the 2-track recorder input. Connect the 2-track recorder output to the 2CH IN jacks.

2. Connect the AUX 1 OUT jack to the input of a reverb or delay unit (or other effects device). Connect the output of the effects device to LINE IN 1 and 2. Input modules 1 and 2 will act as an effects return.

3. Set the INPUT selectors to LINE for channels 1 and 2 (effects returns).

4. Set the INPUT selectors to LINE for channels 5-8 for tape playback.

5. Set all the ASSIGN controls to 1-2.

6. If you have a stereo effects unit, pan input 1 far left; pan input 2 far right. This creates a stereo effects return.

7. Set input faders 1 and 2 to 0. This is the overall effects return level.

8. Monitor STEREO MASTER.

9. Meter STEREO.

10. Set the STEREO MASTER to +6.

11. If you're recording off the stereo output, turn up the bus 1 and 2 gain pots to 0. If you're recording off buses 1 and 2, turn up the bus 1 and 2 faders to 0.

12. Set the bus 1 pan far left; set the bus 2 pan far right.

13. Set the faders near 0.

14. Set MEMORY 1 just before the beginning of the song to be mixed.

15. Play the tape. Do the mix on input modules 5-8 (for tracks 1-4 respectively). Set faders for the desired mix; set EQ, pan, and AUX 1 sends.

16. While setting the mix, set the record level so that several red LEDs light during the loudest passages. Adjust the input level on the 2-track recorder so that its meters deflect to the optimum level.

17. At the end of the tune you're mixing, set MEMORY 2. Enable AUTO RTN. Rewind the tape and practice the mix.

18. When everything is set the way you want it, go to the beginning of the tune, start the 2-track machine in record mode, and record the mix.

19. To hear the 2-track playback, press 2CH on the MONITOR selector.

### FIELD TESTS

I tested the Fostex 460 by recording a synthesizer sequence and overdubbing acoustic drums. The sound quality was excellent for the price, maybe not quite as clean as a separate mixer and open-reel recorder, but very impressive. A little crosstalk between tracks was audible, but this was not a problem in practice.

I also recorded some compact discs and compared the playback to the source. They were remarkably similar. The CD was very slightly clearer. I'm amazed how well cassette recorders work these days.

All the controls worked as described, except for the faders. The Owner's Manual says that you should normally set each fader near  $\pm 5$  dB before the INPUT TRIM is adjusted. I had to set the fader around -22 to obtain a 0 dB recording level, which is unusual. Fader settings near 0 worked well during mixdown.

The unit let me create about any sound I wished; it's flexible enough to work with many signal processors simultaneously. The EQ sounded very good. Controls were smooth operating and noise free. Tape operation was especially impressive and convenient. In all, the Fostex 460 is highly competitive, has many unique features, and is well worth investigating.

The elaborate mixer almost seems like overkill for the four-track format, although the quality of the cassette deck is well matched to the mixer. You'll have to decide whether the extra convenience and flexibility of an 8-track recorder are worth the price. ☐



# Ad Ventures

BRIAN BATTLES

● Producing radio commercials is no job for amateurs. As regular readers of this column know, putting together top-notch advertisements requires skill, practice, intelligence and talent. It used to be that way with music, too. But now we in the recording biz have the player pianos of the 80s: MIDI instruments. Why, with some of the fancier keyboards and computer programs, you can compose and play your own original or customized jingles and music beds, and you don't even have to be a musician anymore.

## MIDI

The term MIDI is an acronym for Musical Instrument Digital Interface. This is an accepted standard developed by the electronic music industry to allow various types and brands of synthesizers and processors to communicate with one another. Common MIDI applications involve hooking up electronic instruments directly to a tape recorder, computer, or to other MIDI devices in order to play music that is synchronized and modified by a main control unit. The MIDI standard specifies methods for programming the equipment to send and receive appropriate digital electronic codes that trigger specific responses based on the parameters invoked by the user.

Now for the English translation: A synthesizer might be set to play a certain sound when you strike a key, and via a MIDI connection, cause another instrument to emit a different sound simultaneously. A typical setup might have keyboard #1 designated to sound like an electronic piano, hooked up via a MIDI interface cable to keyboard #2, set up with a string bass sound, which is chained in turn to a third keyboard patched to emulate a string section, and so on (*Figure 1*). I get a charge out of playing a keyboard that is set as a drum kit so that one key is the kick drum, another is the snare, the next is a tom, then a floor tom, followed by a closed hi-hat key, an open hi-hat, a ride

cymbal, and a crash cymbal, and have a sequencer programmed to follow me with a bass guitar and other instruments wherever my diaphonic fingers may wander. It is a sublime and exhilarating experience to pound out the sound of an entire rhythm section just by playing a "piano."

In anything other than the most rudimentary MIDI systems, a personal computer is often patched into the chain, and its software code lets the user choose from various available voices, tones, rhythms, melodies, and counter-melodies to produce an astonishing array of coordinated pat-

*Figure 1. A schematic of a possible MIDI configuration.*

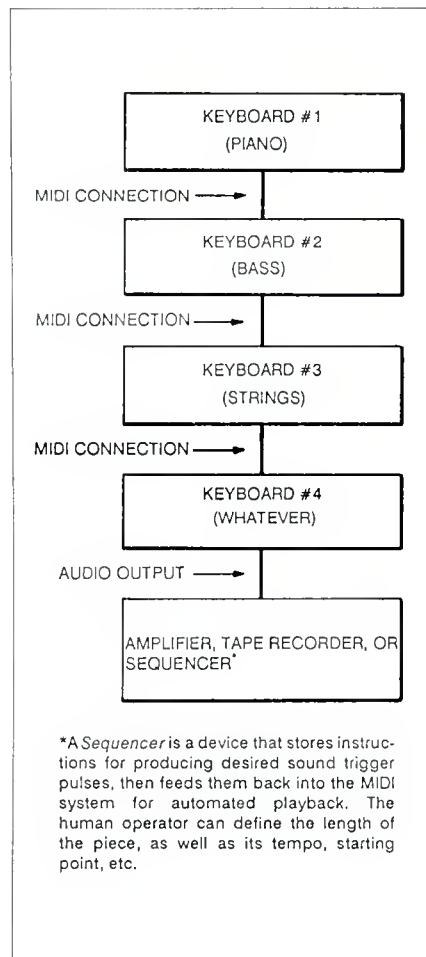

terns based on pre-determined codes. The facilities available to the user include electronically synthesized sounds, "sampled" pieces of live instruments, signal processing functions, and combinations thereof. (Sampled sounds are actual "real-life" audio events that are digitally recorded and stored on microchips or magnetic disks that can be accessed at any time to suit the user's desire. Most of the time the sampled sounds available on a synthesizer are musical instruments or sound effects, and they can be played back "as is," or after being modified by electronic circuitry. An example was shown in the motion picture *Ferris Bueller's Day Off*, in which actor Matthew Broderick as the title character calls his school to report that he is staying home sick, and uses a keyboard to produce an assortment of coughs played at various pitches by striking different keys.) More about sampling in a moment.

## INFINITE COMBINATIONS

Depending on the configuration of hardware and software you have available, you can use MIDI-linked devices to produce an infinite combination of musical and non-musical compositions. This presents some interesting possibilities in radio commercial production. Even individuals untrained in music can obtain computer programs that let them enter series of notes and voicings which can be very effective as background music beds and even jingles. It helps to know the rudiments of playing keyboards, though, since you work faster if you can actually play the parts right through. If you are more of a technician than a musician, you'll still find that a simple note-by-note composition can be entered and stored to the MIDI setup via instrument or computer keyboard, then edited, copied, processed and altered to provide whatever sounds you're looking for.

This is a point of debate in the music and recording industry. As producers, it's absolutely wonderful to be able to

score and perform great-sounding music without hiring expensive composers, arrangers and players. On the other side of the yen, though, plenty of angry musicians feel that they're being denied a lot of potential work by the widespread use of synthesized music. Musicians like Will Lee, Harry Lookofsky and Bernard Purdie aren't standing in bread lines yet, but session players who mainly work with low budget productions are finding it harder to pick up lots of extra work.

Then there are the thousands of bonafide musicians (many of whom are also producers) who welcome the added possibilities and efficiency of working with electronic instruments, embracing MIDI as an adjunct to their talents.

There is controversy between the two categories of individuals whom I call the "Organics" vs. the "Electronics." According to Organics, it can be argued that serious musicians who have devoted a major part of their lives to perfecting their playing skill are being swept aside by the insurgence of microchips that closely duplicate fine virtuoso performances in a fraction of the time—and at a fraction of the cost—of hiring real live people. Many complain that synthesized music lacks the soul of live music.

#### A WIDER RANGE?

The Electronics contend that synthesizers and MIDI offer many benefits. Beside the economic aspects, their view is that they can now prepare compositions they would not otherwise attempt; the equipment is available around the clock and is consistently in peak condition to perform; they don't have to deal with temperamental *artists*, and they have opened the door to a much wider range of musical possibilities.

There is no right answer to this controversy; it's all a matter of opinion. Some call the Organics "snobs," and others call the Electronics "hackers." You are free to choose which side you agree with; in this column we are going to examine some of the possibilities of putting synthesizers to work in commercial production, and see how we can all benefit from the latest technology.

If you are not a musician, you may doubt the value of laying out a lot of cash for these newfangled instruments. But, many producers figure out how much money they can make by putting together their own original pieces, and

use the resulting figures to determine how much they can afford to invest in MIDI gear. MIDI capability can open up bold new areas of commercial production, as well as bring in new customers for conventional sessions by offering expanded services to musical clients. If you get particularly good at operating the equipment, you could consider offering MIDI tutoring to neophytes in your area.

Don't overlook the fact that you also may qualify for certain types of tax deductions and depreciation if you are using your MIDI equipment primarily for business. Consult your accountant or tax attorney. If you happen to have the cash on hand to purchase things like MIDI instruments, tape machines, consoles, processors, personal computers, furniture, etc., you may find that your tax benefits will make the cash outlay quite attractive. As a general rule, though, you should never invest in equipment unless you have good reason to believe that you will squeeze maximum use from it. If you can figure out how much more the hardware will help you earn, then subtract the cost of buying it, this determines the "break even" point that makes it worthwhile.

**HINT #1: Consider renting your stuff out to friends occasionally to help offset the cost of anticipated downtime. Idle equipment costs you money. Just be sure that they are sufficiently liquid financially to be able to afford repairs or a replacement in the event of damage or loss.**

If you are already fortunate enough to own some of this equipment, you have many possibilities open to you with regard to selling your services to radio and TV stations, recording studios, production houses, and advertising agencies. The majority of such businesses do not have sufficient applications to warrant the purchase and operation of these systems, and your availability on an "as needed" basis can be an attractive option for them. Consider these principles:

#### MIDI AND THE PRODUCER

To the producer of radio commercials, MIDI saves time and money mainly by providing the capacity to try out many things quickly and cheaply. The two main types of MIDI sounds are 1) synthesized and 2) sampled. Synthesized sounds are those created purely by electronic means, just like in

the old days when Moogs and Arps were rigged up with zillions of patch cords and dial settings to approximate a realistic instrument tone. Synthesized sounds originate as pure audio-frequency electrical waveforms emitted by oscillators (similar to the output of a test-tone generator), and are fed through circuitry that modifies the sound with filters, modulators, and so forth. On the other hand, sampled sounds are snippets of actual live recordings of real instruments, sound effects, and even human voices. Nowadays, the parameters are stored on microchips, magnetic diskettes, or cartridges for playback whenever needed. Want to overdub a string part? No need to call the musician's union, just press a couple of buttons and you're now playing back your piece with a string section. Would that sax solo sound better as a guitar? A couple of keystrokes and you change it. While you tamper with wild abandon, you also get to save any revisions as well as the original, too, so there's no harm done if you pick a truly dreadful option.

If you don't have the knack or inclination to write humorous or novelty radio advertising copy, you are probably most interested in preparing musical beds and logos. This kind of session is ideally suited to use of MIDI equipment.

If you wish to market your capability to produce music for commercials using your MIDI system, you must do the same thing as you would with other types of music. Compile a demo tape of several different tunes, including as wide a variety of styles and techniques as possible. If you're a fast worker, you might even slap together a custom jingle for the actual client you are calling on, or an improved variation on the advertiser's current theme. Put several minutes of material on a single cassette and bring it by the prospect's place of business. (If at all possible, try to make an appointment first, and be sure you bring along a decent portable cassette player or "boom box," in case there isn't one available when you get there.)

#### BEING MORE THAN JUST PRESENTABLE

On sales calls, carry business cards and wear a decent suit of clothing. Buy or borrow a briefcase or attache to carry your contracts, proposals, notepads, pens, calculator, brochures, etc. Shine your shoes, comb your hair, and take along your Binaca. This is the

time to project the image of a straight Madison Avenue professional. You can afford to look and act like a grubby producer after you've delivered the completed commercial spots and cashed the check.

Ah, yes, the check. How much? Unfortunately, there is no simple formula or equation for calculating your fees. How much competition do you have? Ask yourself objectively: Are the other production companies as good as you are? Better? Worse? You must also decide how to position yourself in your geographic market. What is your proposed image? New and fresh? Years of experience? A strong local reputation in the music scene? Some kind of exclusive service to offer? Do you hope to become the high-end "Rolls Royce" production company, or are you after less profit per job but greater market share? Perhaps you are just an entry-level entrepreneur who wants to pick up whatever you can get. Should you stress effectiveness? Quick turn-around time? Superior customer service? Special discounts on repeat orders? These are all critical parts of your marketing plan.

If you have partners or close friends in your business, you should hold a meeting to examine the strengths and weaknesses of your operation. Since nearly every studio operator I know hates the thought of door-to-door selling, think about hiring a sales representative who knows something about your field to do the actual legwork. See if you can get one who'll go on a straight commission basis, at least to start. To promote your service, blow the dust off the checkbook and place a few ads of your own. Most good-sized communities have some sort of business newspaper, directory or magazine for suppliers to reach businesses. Price an ad in the Yellow Pages. Distribute flyers. Mail press releases about your new venture to the newspapers, Chamber of Commerce, and broadcast stations. Test direct mail pieces. A hot strategy is to contact a sharp radio station Account Executive who just may have a few clients who could be good prospects for your service. After all, great spots get big results, and results equal renewals for the station. Build a base of allies in the broadcasting industry.

To get some reference point in your locality, try to obtain rate cards from other area production houses that have comparable talent and facilities. Generally, my philosophy is that, as the new kid in town you'll have to undercut

the other people's prices a bit in order to start building a respectable client base. Your rates can be pushed up as necessary once you've established yourself as a "name" in your market. Better to start out making less and getting more jobs, than to go door-to-door for months before some business decides to take a chance on you. Get your rate card typeset and run off at a good offset printery. It gives you a more stable and honest image. You won't fool anyone with a cheap, homemade computer printout (unless you have a laser printer and some really fine software).

**HINT #2: Shop around to find a dependable local print shop and have them take care of all your stationery, envelopes, brochures, contracts, standard forms, and so on. You'll be more likely to get a good price, and the quality won't vary from piece to piece. Your printer will also give you expert advice in design, layout, and type selection.**

I started by writing about MIDI, and somehow slid into a discourse in Fundamentals of Marketing 101. That's the trouble with columnists who work for bi-monthly publications. Too many ideas, too few issues to cram them into. And you clowns who keep sending me letters and calling me on the phone don't make it any easier, you know. Just because it seems like thousands of studio operators read *Ad Ventures* since it's the only such place to find techniques to help them get rich and build their businesses by doing radio commercials, you'd think a guru could get a little peace around here now and then!

#### TALKBACK MIC

Thanks to Joseph Ruscito of Frankensounds, Toms River, NJ for the phone call that inspired this column...A mention to my friends here in the Rockies: Thanks to Keith Baxter of Baxtrax in Denver, CO for a couple of helpful MIDI lessons...Ragan Roush of Points West in Lafayette, CO and Rich Sanders of Salt Productions, Broomfield, CO, I enjoyed our collaboration and look forward to many more — congrats on the success of your presentations, glad I could be of service...Joe Jackson of Jackson Sound Productions, Englewood, CO, I was thrilled with the quick turn-around on my ReVox...Hot stuff in the Rockies as jazz comes to 94.7 FM, KHIH, Denver,

CO. Hats off to ace program director Val MacIntosh, and thanks to afternoon news queen Ellynne Dale for fabulous voice-overs and other help...Patrick Cullie ("The Sixth Eagle") of Coupe Studios in Boulder, CO, I appreciate the call regarding Western Maid Pickles...For your reading pleasure, check out *CareerTracking* by my boss and high school chum, Jimmy Calano, and his partner Jeff Salzman. It's published by Simon and Schuster, and available in bookstores everywhere...To the Right Coast: Hello to DJ/actor/voice-over star Marc Coppolla of WXRK, New York, NY (yes, he's the nephew of director Francis Ford Coppolla and brother of actor Nicholas Cage). Watch for his silver screen appearance in *Dracula's Widow* along with Sylvia (*Emmanuelle*) Kristel. And, remember to pronounce it COPE-o-la, with the accent on the first syllable! I have yet to hear from any of the distaff members of our industry. There are lots of you out there (I've worked with quite a few, so I know this isn't some kind of boy's club). Aren't any of you talented female producer/engineers going to send in some samples or questions?

#### OFF MIC

Coming soon: As soon as I get my computer modem all set, I'll try to get logged onto a BBS for your personal questions, comments and suggestions. Perhaps we can even get some useful professional networking going... Shameless Self-Promotion of the Month Dept.: check out the gold-plated throat of yours truly on the new monthly *CareerTape* business news cassette subscription service, and also on my newly-published audio tape learning program *How to Listen Powerfully* (four idea-packed cassettes, just 39.95, with a one-year money back guarantee!) For info on either one, call CareerTrack Publications, Inc. at 1-800-334-1018. Also, the offer still stands to let me know if you want to be on the mailing list for my forthcoming audiocassette package on radio commercial production, featuring examples of award-winning spots and the techniques you can use in your very own studio. At this writing interest is strong, so don't miss out. There'll be a hefty discount for faithful *db* readers when it rolls out. (If you'd like to see a book based on *Ad Ventures*, grab a pen and start pestering the editors here...I can't do it alone!) 

# For Your Audio Library

## The Recording Studio Handbook

by John Woram

\$39.50

The Recording Studio Handbook is an indispensable guide with something in it for everybody. It covers the basics beautifully. It provides in-depth insight into common situations and problems encountered by the professional engineer. It offers clear, practical explanations on a proliferation of new devices. In this updated edition, among the items covered are: Transducers, signal processing, noise reduction, recording techniques and more . . . In addition, it has been expanded to feature three all-new chapters . . . chapters on the in-line recording studio console, digital audio and time code implementation.

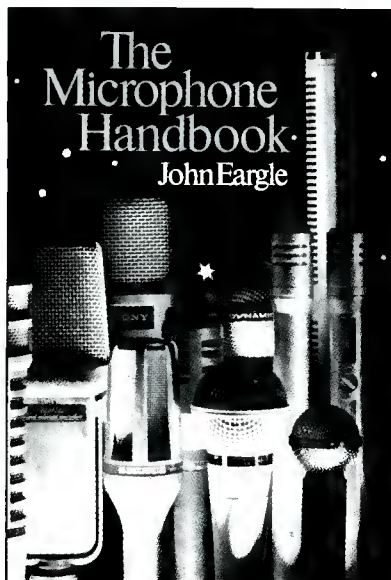
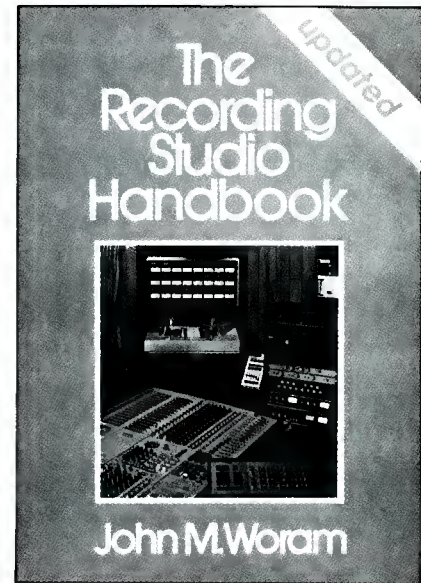

## The Microphone Handbook

by John Eargle

\$31.95

Completely up to date, this vital new handbook is a must for any professional whose work involves microphones. Among the topics covered are: Directional characteristics—the basic patterns, using patterns effectively, microphone sensitivity ratings, remote powering of condensers and proximity and distance effects. Other topics include: Multi-microphone interference problems, stereo microphone techniques, speech and music reinforcement, studio microphone techniques and microphone accessories. You'll find yourself reaching for it every time a new or unusual problem crops up.

Please send the books indicated below:

\_\_\_\_\_ copy(s) of The Microphone Handbook at \$31.95 plus \$2.00 for postage and handling per book.  
\_\_\_\_\_ copy(s) of The Recording Studio Handbook at \$39.50 plus \$2.00 for postage and handling per book.  
\_\_\_\_\_ Both books at \$67.50 plus \$3.00 for postage and handling. (Over 5% savings!)

Outside the U.S. A.: Please add \$3.00 per book for postage. checks must be made in US funds drawn on a US bank.

Mastercard  Visa  Exp. Date / \_\_ / \_\_

--	--	--	--	--	--	--	--	--	--	--	--	--	--	--	--	--	--	--	--

Name \_\_\_\_\_

Address \_\_\_\_\_

City \_\_\_\_\_ State \_\_\_\_\_ Zip \_\_\_\_\_

Signature \_\_\_\_\_

Send to ELAR Publishing, 203 Commack Road, Suite 1010, Commack, NY 11725.

# New Products

## EXPANDER/GATE

● Apex Systems Ltd. has introduced the 612 Expander/Gate. It is a true expander, using downward expansion with a variable ratio (1:1 to 20:1), allowing an infinite variety of dynamics control. With high ratio, the 612 becomes a gate. It is also a ducker, allowing a key input to lower (duck) the level of audio input. It is the first product to use the latest in VCA technology, the Apex VCA 1001. This provides an order of magnitude lower distortion, high speed and stability, low noise, and the sonic characteristics of a straight wire. Key features of the 612 are variable high and low pass filters which may be switched in and out of the circuitry, eternal key switch, adjustable threshold from -30 to +20 dBm, variable attack time adjustable from 2 $\mu$ sec. (with no clicks) to 100 msec., adjustable release time from 40 msec. to a full 4 sec., adjustable expansion range from 0 to 100 dB, servo-balanced inputs and outputs, and multi-voltage operation.

*Mfr.*- Apex Systems Ltd.

*Price*- \$795.00

*Circle 40 on Reader Service Card*

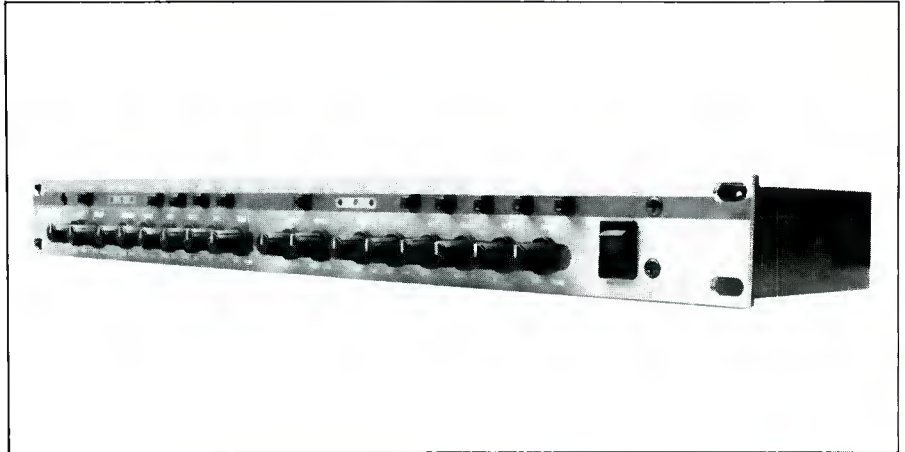

## RACK MIXER

● Carvin Corporation has designed the MX601 series of professional rack-mount 6-channel mixers. The MX621 delivers a full 200 watts rms, and the MX641 delivers 400 watts rms with enough power for concert applications. Features include a rackmount chassis (simply remove the OZITE enclosure), deluxe low-noise preamps and a built-in phantom +48 V power supply on the MX641 for condenser mics.

*Mfr.*- Carvin Corporation

*Price*- \$499.00 (MX621)

\$599.00 (MX641)

*Circle 41 on Reader Service Card*



## BULK ERASER

● Garner Industries introduces a bulk eraser for 1500 OE particle tape. The Eliminator 4000 features a design (patent applied for) that generates a degaussing force of 4000 oersteds. This degausser will erase 1500 oersteds metal particle tape to a -75 dB, well into the noise level of new tape. It utilizes the conveyor belt transport system.

*Mfr.- Garner Industries*

*Price- \$7990.00*

*Circle 42 on Reader Service Card*

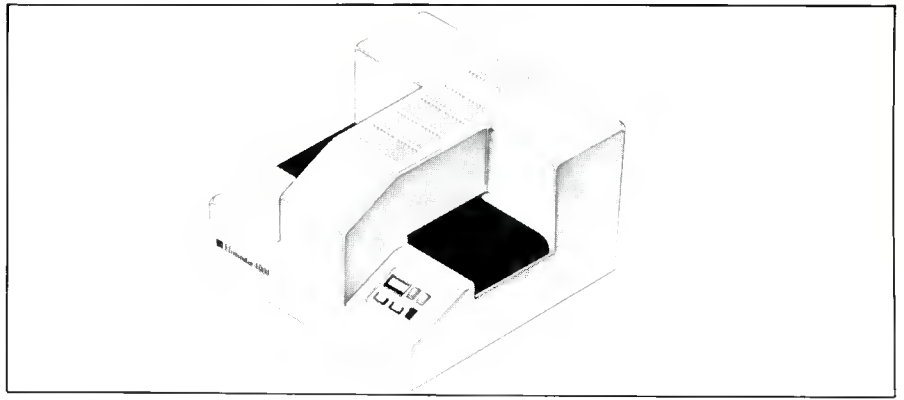

## PATCHBAY

● Pro Co Sound Inc. is offering the PM-148, a 48-point patchbay, which provides 48 unbalanced 1/4-inch phone jacks on the front panel (2 rows of 24 each) connected to 48 similar jacks on the rear of the single space, rack-mounting unit. The rear-panel jacks allow the use of pre-fabricated cable assemblies for connecting equipment to the patchbay, allowing rapid installation. The unit has 48 points; this reduces the rack space needed for the patching system and allows more logical patchbay layouts. Also featured is the "Selecta-patch" switch for each pair of front panel jacks which allows fast and easy user-modification of the system's signal flow by controlling the way the

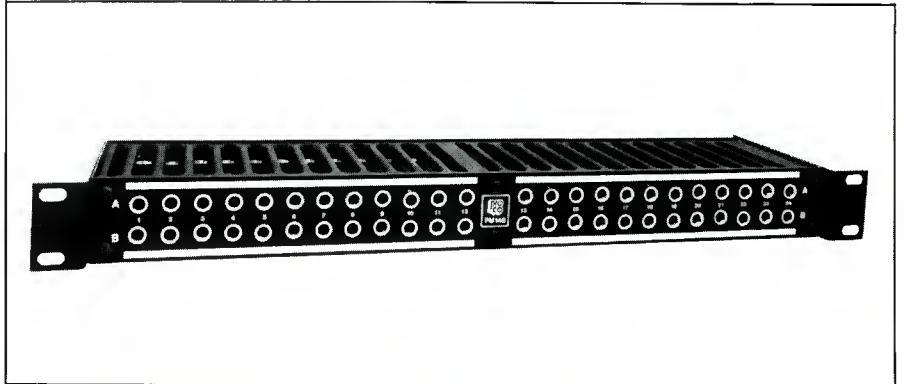

rear panel jacks are connected to the front panel jacks. A switch determines whether a pair of jacks is full-normalled, half-normalled, paralleled or open.

*Mfr.- Professional Consultants in Sound*

*Price- \$299.00*

*Circle 43 on Reader Service Card*

## LOUDSPEAKERS

● Community Light & Sound Inc. has introduced the CS Series II loudspeakers, comprised of nine models ranging from the portable CS25 to the full-range CS70. Re-designed elements in the crossover networks have improved the fuseless protective circuitry, and provided superior crossover filter performance in the two and three-way systems. The loudspeakers deliver uniform wide-angle dispersion, low distortion, and vocal clarity. High sensitivity and high power handling characteristics also mean that high output levels can be obtained with even modest-sized economical amplifiers, while the reserve capacity is still at hand to use the most powerful amplifiers when extreme SPLs are required.

*Mfr.- Community Light & Sound Inc.*

*Price- range from \$270.00 to \$900.00*



*Circle 44 on Reader Service Card*

## MASTERING TAPE

● Ampex Corporation's Magnetic Tape Division has announced Ampex 478. It is a low print mastering tape line that incorporates a new design and is intended for radio broadcast customers, film and video post-production houses, and recording studios where low print mix down is desired. The tape features an improved low print performance that reduces print through to extremely low levels, providing minimum audible print signals. A new high-speed backcoating process provides the packing needed for flangeless use, thus reducing edge damage, pop strands, and the need to slow speed re-wind. It is available in CCIR and NAB formats, and in an expanded number of configurations.

*Mfr.*- Ampex Corporation

*Price*- range from \$9.38 (1/4-in. by



600-ft. on 5-in. plastic reel) to \$60.75 (1/2-in. by 2500-ft. on NAB metal reel).

*Circle 45 on Reader Service Card*

## MUSIC LIBRARY

● The SoperSound Music Library announced the release of its collection of buy-out production music, Series XIII, composed by musician Paul Potyen. The collection features an eclectic offering of mellow jazz, driving televi-

sion-style theme music, and contemporary high-tech industrial music. According to Dennis Reed, president of SoperSound and producer of the release, the company wanted to offer almost a mini production library; one that will find use in broadcast, in-

dustrial, training or educational applications.

*Mfr.*- SoperSound Music Library

*Price*- \$225.00 (album)

\$245.00 (CD or cassette)

*Circle 46 on Reader Service Card*

## STEREO MIC

● Sanken has introduced the CMS-9 professional, portable MS-stereo microphone. It has a design which incorporates a mid-side sum and differencing processing circuit inside its body, and outputs normal stereo signals which can be input directly to any field recorder or portable DAT machine equipped with L-R and 48 V phantom power. Cardioid pattern response is on the axis for stereo news gathering, music and field effects recording. The microphone weighs 200 grams, and its standard 19 mm diameter allows use with any standard hand grip. The two-layer windscreen assures maximum immunity to noise interference. The product also features a one-micron titanium diaphragm that is light, strong, corrosion-free and immune to temperature and humidity changes. It has a dynamic range of 108 dB, a nearly flat frequency response, and inaudible self-noise (19 dB or less) for a clear stereo image and clean uncolored sound.

*Mfr.*- Sanken

*Price*- \$1850.00



*Circle 47 on Reader Service Card*

# Classified

## MIXING BOARDS

Factory direct, models for home recording and live sound. Quality boards priced to move. Quantities are limited, call while supplies last. For info and prices call (201) 423-2176. Ask for Dave Fox.

FREE 44pg Catalog & 80 Audio/Video Applic.  
PHONO, MIC, PWR SUPP, EQ, 250 PRODUCTS  
TRANS. ACN, PRESS  
TAPE, VIDEO, BOXES  
LINE, OSC  
1-in 16-out Video  
2-in 18-out Audio  
2-in 24-out Audio  
4-in 1-out Audio Mixer  
Video & Audio Dist. Amplis.  
RGB-Sync Dist. Amplis.  
Routing Switchers  
OPAMP LABS INC (213) 934-3566  
1033 N Sycamore Av LOS ANGELES CA, 90038



## OTARI 5050 TAPE DECK

For sale, one Otari 5050 2-channel tape deck. In perfect operating condition. Meets all original specs. Heads, good. Complete with loose-leaf instruction/service manual. Full price: \$750.00, FOB New York. Write Dept. 38, db Magazine, 203 Commack Road, Suite 1010, Commack, NY 11725.

WANTED: Pultec EQ's. We will pay \$1,000 for almost any Pultec program EQ modes EQP1/EQP1A/EQP1A3. Also wanted EQH2/EQH3/MEQ5/MAVEC/MB1/ITI and Sontec EQ's. Any tube or ribbon microphones and limiting amps. Please call or write to: Dan Alexander Audio, 2944 San Pablo Ave. Berkeley, CA 94702. (415) 644-2363.

SPEED CONVERSIONS for Tascam models 38, 34, or 32... Switchable 15ips and 30ips. Authorized and field service for most major name keyboards, tape machines, mixers, amps. Major credit cards. Santorelli Electronics Productions, Federal Square Professional Building, 393 Sunrise Highway, Suite B-3, West Babylon, New York 11704. (516) 661-2454.

Closing date is the first of the second month preceding the date of issue.

Rates are \$1.00 per word with a \$25.00 minimum. Boxed ads are \$40.00 per column inch. db Box Numbers are \$8.50 additional for wording "Department XX" plus \$1.50 additional for postage and handling.

Quantity discounts are: 3X - 15%; 6X - 30%.

ALL CLASSIFIEDS  
MUST BE PREPAID

Send copy to:  
db, The Sound Engineering Magazine,  
203 Commack Road,  
Suite 1010, Commack,  
NY 11725.

## WE'VE MOVED!

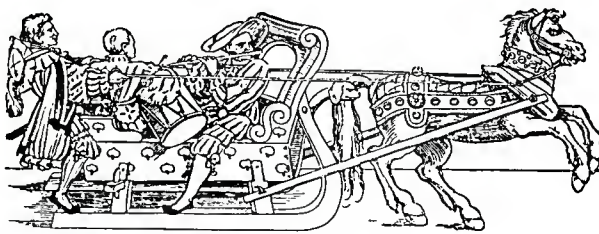

### db Magazine

### ELAR Publishing

There's a new address:  
203 Commack Road, Suite #1010  
Commack, NY 11725

The telephone number is now:

### 516-586-6530.



# People, Places... & Happenings

● **Custom Duplication Inc.** announced that it has installed professional real time DAT duplication, labeling and packaging in their headquarters facility in Inglewood, CA. According to **Bob Hively**, president and chief executive officer, the company has ample duplicating capacity in place and are presently running orders for domestic record labels. They supply the record companies all the specifications for the labels, J cards and long boxes for the DAT cassette. Duplication is done on professional recorders, recording digital to digital at 44.1 kHz sampling rate with the digital flags for copy protection.

● At **Altec Lansing**, **Gary Jones** has been appointed Technical Services Manager by Larry Phillips, Director of Sales. Gary will be responsible for teaching the technical aspects of all Altec Lansing products to the sales force and contractors.

In April, Altec Lansing shipped products to be installed in the Soviet Union for the upcoming Reagan/Gorbachev summit meeting. The equipment included power amps, crossover, suppressor, loudspeakers, horns, throats, and compression drivers. The system is being installed in the "Press Center" where journalists from around the world will be briefed, whether by representatives from both countries or by Reagan and Gorbachev.

● **Robert E. Seidenglanz**, Chairman of the Board of Hollywood-based **Pacific Video Inc.**, has announced the acquisition of the assets of United Color Lab as part of a major multi-million dollar research and development oriented expansion program. The new company will be called **Pacific Film Laboratories**. The UCL acquisition comes after Pacific Video's acquiring controlling interest in Tegra Enter-

prises, Inc., a company that operates film lab and video post-production facilities in Vancouver, Canada. Seidenglanz noted that the new lab is an important element in Pacific's long-range plan for providing a total one-stop post-production service facility for film producers who use Pacific Video's Electronic Laboratory services.

● **Beachwood, Ohio-based Telarc International** won three classical Grammy awards on March 2, 1988. **Robert E. Woods**, label president and producer, won for Classical Producer of the Year. **Jack Renner**, Telarc's chairman and recording engineer, won a Grammy for his work on the Atlanta Symphony Orchestra and Chorus' recording with conductor Robert Shaw of the Fauré and Duruflé, voted the Best Engineered Recording, Classical. The award for Best Choral Performance (other than opera) went to Telarc's recording of Hindemith's "When Lilacs Last in the Dooryard Bloom'd," also performed by the Atlanta Symphony Orchestra and Chorus, conducted by Robert Shaw.

● The electronics program at Danville's **Monte Vista High School** boasts a four-camera, full-color television studio and complete audio and video production and editing facilities. The program has sent hundreds of its graduates on to jobs in network television, teaching and major video production facilities throughout the state. Under the direction of electronics teacher **Chester Farrow** and with the support of technical education administrator **Stan Greenspan**, the students have produced a weekly magazine format TV show, "Just For You," which has aired on area cable channels for fourteen consecutive years. The show, which is done live, is run entirely by students, from on-air personalities to pro-

ducers and directors to camera operators.

● **Imax Systems Corporation** announced that it has acquired a 51 percent interest in **Sonic Associates, Inc.** IMAX/OMNIMAX uses the largest film frame in motion picture history, the most advanced projector ever built, specially-designed theaters and high fidelity, six-channel sound. **Bill Breukelman**, chairman of Imax Systems Corporation, explains that the new relationship with Sonics is a step in expanding and enhancing the new medium which the company created twenty years ago.

● **Studer Revox America** has made some changes in its staff and organizational structure. **Chris Ware** has been appointed Manager of Studer Direct Sales. Ware will be relocating with the company to Nashville, TN. He will be responsible for managing sales of all non-dealer Studer branded products sold directly by the company. Overall sales and administrative efforts will be headed by Executive Vice President **Bill Muggler**. Other changes to take place include expanding operations and sales/service personnel on the West Coast.

● A distribution and support office for the entire range of **AMS** and **Calrec** products has been opened in the U.S. The office will supply all AMS and Calrec reps and dealers across the U.S. and become the service center for everything from AMS audio processors to Calrec consoles and the Soundfield microphone. **Nigel Branwell** will be in charge of AMS Industries Inc.

● The **National Academy of Recording Arts and Sciences** has named **Michael Greene** to become its full-time

permanent president beginning in March, it was announced by the N.A.R.A.S. Chairman of the Board of Trustees, **Alfred W. Schlesinger**. Greene will office at the national headquarters of the Academy in Burbank and will serve on a professional basis under the direction of the annually-elected Chairman of the Board of Trustees and the trustees who represent the seven local N.A.R.A.S. chapters. Schlesinger will continue as chairman.

- A new 24-track recording studio was inaugurated at the **University of Miami** in the Gusman Concert Hall. Built by the students of the School of Music's program in Music Engineering, the new room features an automated Sony MXP 3036 recording console which was acquired through the generosity of Sony Professional Audio Products. The new control room contains a Synclavier digital music system and is equipped for digital recording. The studio is used by the Music Engineering students for recording of University concerts and in-house productions as well as for maintenance training.

- Public radio station **KUSC** has received two awards for broadcast excellence, acting General Manager **William Kappelman** has announced. A new music program from the Los Angeles Philharmonic broadcast season received an Ohio State Achievement of Merit, and "Festival Magazine," KUSC's special radio coverage of the Los Angeles Festival, won the Local Radio Series Award from Sigma Alpha Iota, the international radio fraternity.

- **WaveFrame Corporation** announced the appointment of **Craig Hunter** and **Gary Rosen** as the Los Angeles and New York branch office managers for the company. In addition, **Gus Skinas** has been appointed product manager. According to **Glenn T. Edens**, president, all three have extensive backgrounds and first-rate reputations in the music and video post-production industries as users, owners, and suppliers of audio equipment. Craig Hunter was most recently sales manager at Everything Audio in Burbank, CA; Gary Rosen served as director of sales and marketing for Time-

Line Inc. **Gus Skinas** spent seven years with Sony Professional Audio Division.

- In a major expansion effort due to increased sales and service requirements, **Neve** has announced the opening of new facilities in New York City and Nashville, Tennessee. The New York office is headed by **Phil Wagner** and the Nashville facility is under the direction of **Tom Semmes**.

- **Bob Wortsman** has been named Manager of Special Projects for **Electro Sound, Inc.**, according to **Bob Barone**, president. Wortsman will work with clients on non-standard applications of ESI products. He will also be the principal liaison with raw materials manufacturers and suppliers to the audio cassette industry.

- **Greg Speer** has been appointed vice president and general manager of **ElectroSound Los Angeles**, according to **Bob Barone**, operations vice president of **ElectroSound Group, Inc.**

- International Manager of **Bruel & Kjaer's Pro Audio Group** **Adrian Weidmann** has moved to the United States to spend the next year at **Bruel & Kjaer Instruments, USA** headquarters in Marlborough, MA. He will initially concentrate on rationalizing **Bruel & Kjaer's** US dealer network. He will then be coordinating a series of educational seminars and presentations throughout the United States directed at producers, engineers and musicians. The seminars will focus on the Series 4000 Professional microphones and their applications, as well as on mic technique in general, acoustics and electroacoustics.

- A range of **Sony** broadcast and professional equipment was used recently to record the video and audio portions of the Metropolitan Opera's program of Strauss' "Ariadne auf Naxos." The event marked the first time a cultural program has ever been transmitted live from the U.S. to the Soviet Union. For every "Metropolitan Opera Presents" television broadcast, the following Sony equipment is used: two PCM-3324 digital multi-track audio recorders, four BVH-2000 1-inch Type C VTRs and a Sony digital encoder. □□

## The Buyer's Guides for 1988

Save each one for a complete guide to the equipment necessary for your studio!

- *Jan/Feb*
- **Performance and Monitor Speakers**
- *March/April*
- **Power Amplifiers**
- *May/June*
- **Tape, Tape Recorders, & Access.**
- **Stands, Cases, Racks.**
- *July/Aug*
- **Consoles and Mixers**
- *Sept/Oct*
- **Mics, Wire, Connectors, Faders.**
- *Nov/Dec*
- **Signal Processing Equipment**



## Microphones

In the studio, over the air or up on stage, there's a Fostex RP mic specifically designed for the job at hand. RP stands for regulated phase, a transducer technology which has been awarded over 20 international patents to date. These mics have the warmth of condensers, the ruggedness of dynamics and a sound as transparent as it gets.



## Headphones

These are more outstanding examples of RP Technology. Model T-20 has become almost legendary among studio musicians, producers and engineers. Its flat response at any listening level and its comfortable design help you listen longer without fatigue. And the sound is so clear and well-defined, critical listening is enjoyable.



## Speaker Systems

You're up & going with Fostex PA systems. Modular designs let you control the sound according to the needs of the event. Stack them, gang them. From a simple portable PA to an entire rig, look to Fostex speaker systems to help you solve your sound problems.



## Powered Mixers

Model MP-800 has 8 inputs and delivers 180 W per channel and Model MP-1200 has 12 inputs and delivers 250 W per channel. These rugged, road worthy stereo mixers have quiet running fans, digital echo, normalled connections at all critical patch points, stereo graphics on the mains and super monitoring flexibility. The best at any price.

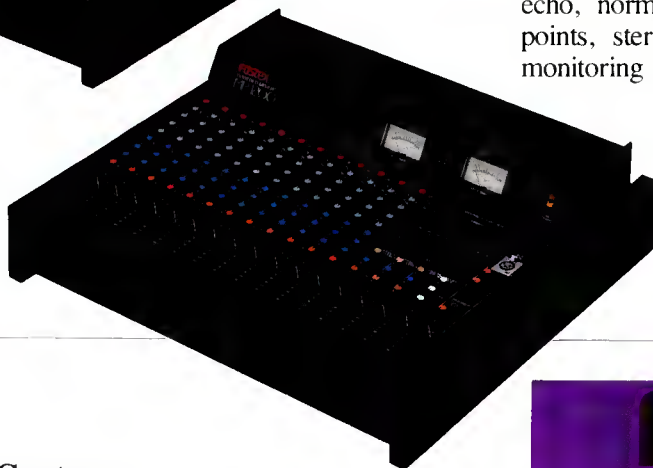

## Complete PA Systems

Look to Fostex for any and all of your PA needs. Complete systems or individual components. High quality sound from input to output.



15431 Blackburn Ave., Norwalk, CA 90650  
(213) 921-1112

© 1987 Fostex Corporation of America



## TAKE CONTROL OF A MAJOR RECORDING STUDIO.

It's time to seize power.

Tascam's Studio 8 puts all the power of a professional recording facility into an 8-track production system that's as easy to handle as your own instrument.

Forget bewildering patch bay jungles. The fully assignable 8 buss mixer sends your signals anywhere you want them with the flick of a switch.

Forget open reel headaches. The unique Load feature loads the tape, senses the end automatically and never lets it run off the reel. And because Studio 8 uses 1/4" tape, you'll never be stuck trying to find someone's rare proprietary tape format.

Forget video hassles. The "One Plug" SMPTE/EBU interface gives you easy synchronizer or editor connections.

But there's something more. Something that's greater than the sum of the features. Startling sound. No other system has Tascam heads. Which means that no other system has the impact and clarity that come from Tascam's thirty years of recording experience.

Quality production is what you do. Do it with a major recording studio. Take control of a Tascam Studio 8.



# TASCAM

© 1987 TEAC Corporation of America, 7733 Telegraph Road, Montebello, CA 90640. 213 726-0303.