

# AUDIO

FEBRUARY, 1958  
50c

Make Your Own  
STEREO PICKUP

*...the original magazine about high fidelity!*



# FROM THE LINE MOST WIDELY USED BY PROFESSIONALS...

## PRESTO High-Fidelity Turntables for Home Installations

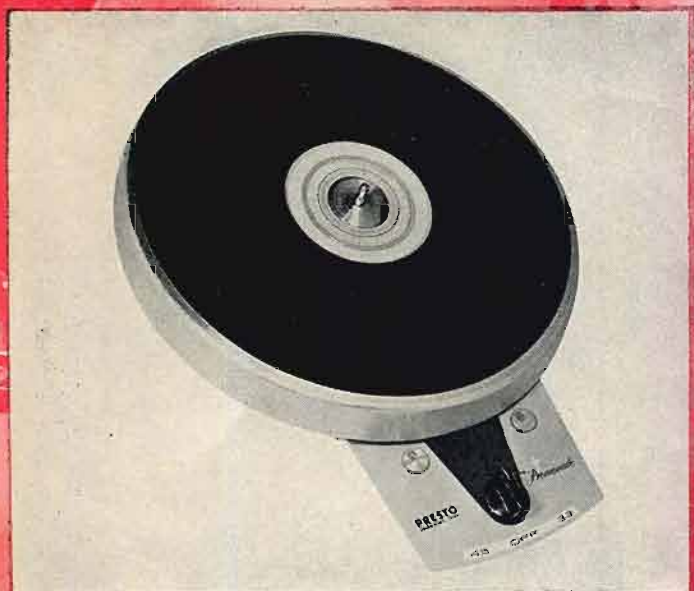

### PRESTO T-2

A crowning achievement in engineering design—the T-2 two speed model offers superb high-fidelity performance at modest cost. Its heavy, balanced aluminum turntable and rugged drive system eliminate wow, flutter and rumble. The interchangeable idler wheels disengage in the "off" position to prevent flats. Heavy-duty, 4-pole motor insures accurate speeds. Shift mechanism permits quick change from  $33\frac{1}{2}$  to 45 r.p.m. while table is spinning. Comes equipped with built-in strobe disc, 45 r.p.m. adapter, and rubber record mat. *Only \$59.50*

### PRESTO T-18AH

Undoubtedly the finest high-fidelity turntable for home use that money can buy. Three speeds; precision-made throughout; wow, flutter and rumble are virtually non-existent. Employs 12", cast-aluminum turntable and constant-speed hysteresis motor. Speed selector has five positions: 45—off— $33\frac{1}{2}$ —off—78. *Only \$131.00*

### PRESTO T-18A

Has all the features of the T-18AH (above) except that it is equipped with a heavy-duty, 4-pole induction motor. *Only \$75.00*

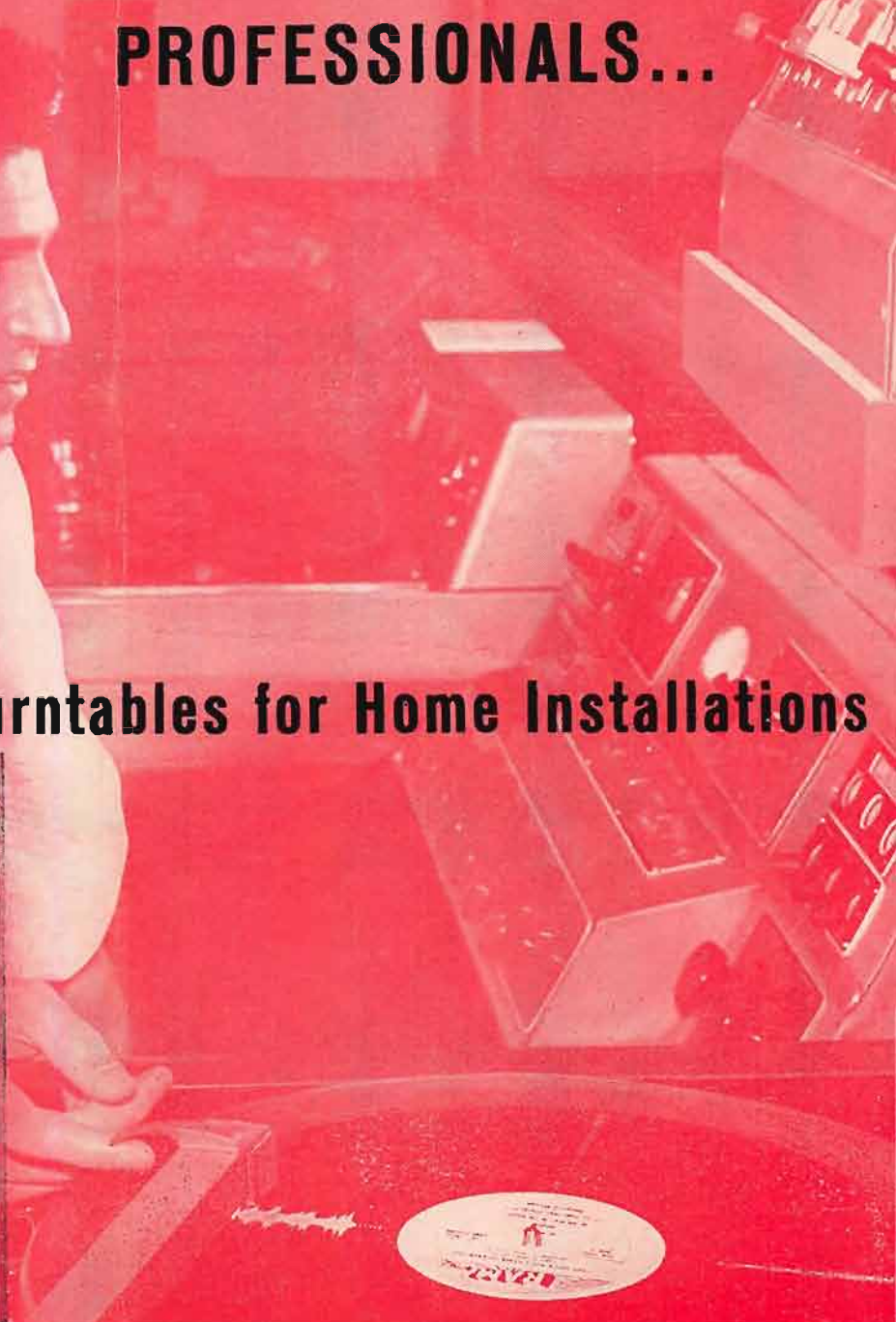

For over 20 years, Presto transcription turntables have been the choice of broadcast-station and sound-studio engineers. Today, more are in professional use than any other make.

Now, Presto offers the audiophile three precision turntables for high-fidelity installations, incorporating many of the design features that have made our transcription turntables famous. See them at your local high-fidelity shop—or for full details and specifications, write for catalog to Dept. G-2, Presto Recording Corp., Paramus, N. J.

# PRESTO

TURNTABLES • TAPE RECORDERS • DISC RECORDERS  
DISCS • STYLI • AND HIGH FIDELITY CABINETRY

A SUBSIDIARY OF THE SIEGLER CORPORATION

# AUDIO

ENGINEERING MUSIC SOUND REPRODUCTION

**C. G. McProud, Editor and Publisher**  
 Henry A. Schober, Business Manager  
 Harrie K. Richardson, Associate Editor  
 Marie Caspe, Assistant Editor  
 Janet M. Durgin, Production Manager  
 Edgar E. Newman, Circulation Director

**Sanford L. Cahn, Advertising Director**  
 Special Representative—

*H. Thorpe Covington,*  
 814 Lincoln St., Evanston, Ill.,  
 Davis 8-8874

Mid West Representative—  
*Sanford R. Cowan, 300 W. 43rd St.,*  
 New York 36, N. Y.

West Coast Representative—  
*James C. Galloway*  
 6535 Wilshire Boulevard, Los Angeles 48, Calif.



**CONTENTS**

|   |    |
|---|----|
| Audioclinic— <i>Joseph Giovanelli</i> .....   | 2  |
| Letters .....   | 6  |
| Audio ETC— <i>Edward Tatnall Canby</i> .....  | 12 |
| Editor's Review .....   | 14 |
| How to Make a Stereo Phono Pickup— <i>C. G. McProud</i> .....   | 17 |
| Custom-Built Corner Horn Enclosures— <i>Laurent Guigon</i> .....  | 20 |
| Amplifier Performance: Specifications and Evaluation— <i>Herman Burstein</i> .....  | 24 |
| Simple Electronic Switch for Magnetic Sound System— <i>Dr. Ing. Pierantonio Cremaschi</i> .....   | 26 |
| Feedback and Distortion— <i>George Fletcher Cooper</i> .....  | 30 |
| Loudness, Its Definition, Measurement and Calculation— Part IV— <i>Harvey Fletcher and W. A. Munson</i> .....                                   | 34 |
| Equipment Review— <i>ISI Model A-10 Loudspeakers—Connoisseur Phono Arm and Pickup—Sargent-Rayment 300M-70 Tuner and 70-watt Amplifier</i> ..... | 36 |
| Record Revue— <i>Edward Tatnall Canby</i> .....   | 42 |
| Jazz and All That— <i>Charles A. Robertson</i> .....  | 44 |
| Book Review .....   | 55 |
| About Music— <i>Harold Lawrence</i> .....   | 56 |
| Los Angeles High Fidelity Show Exhibitors .....   | 58 |
| New Literature .....  | 59 |
| Price Discrimination in Wholesale and Retail Sales— <i>Albert Woodruff Gray</i> .....   | 60 |
| New Products .....  | 62 |
| Industry Notes .....  | 79 |
| Advertising Index .....   | 80 |

**COVER PHOTO:** One of the installations crafted by Murray Newton, custom audio specialist, of 7 West 73rd St., New York City. Altec tuner and amplifier are neatly housed behind the tambour doors.

**AUDIO** (title registered U. S. Pat. Off.) is published monthly by Radio Magazines, Inc., Henry A. Schober, President; C. G. McProud, Secretary, Executive and Editorial Offices, 204 Front St., Mineola, N. Y. Subscription rates—U. S. Possessions, Canada and Mexico, \$4.00 for one year, \$7.00 for two years, all other countries, \$5.00 per year. Single copies 50¢. Printed in U.S.A. at Lancaster, Pa. All rights reserved. Entire contents copyrighted 1958 by Radio Magazines, Inc. Entered as Second Class Matter February 9, 1950 at the Post Office, Lancaster, Pa. under the Act of March 3, 1879.

**RADIO MAGAZINES, INC., P. O. Box 629, MINEOLA, N. Y.**

for Ultimate Fidelity

# SHERWOOD\*



\*outstanding honors bestowed, unsolicited, by most recognized testing organizations.

No matter what your source of music—FM, your own discs, or tape—you will enjoy it at its best coming from Sherwood's complete home music center... most honored of them all! Sherwood tuners for example...

First to achieve under one microvolt sensitivity for 20 db FM quieting increases station range to over 100 miles. Other important features include the new "Feather-Ray" tuning eye, automatic frequency control, flywheel tuning output level control and cathode-follower output.

Model S-2000 FM-AM Tuner \$139.50 net  
 Model S-3000 FM (only) Tuner \$99.50 net

For complete specifications, write Dept. A-2

# SHERWOOD

ELECTRONIC LABORATORIES, INC.  
 2802 West Cullom Avenue, Chicago 18, Illinois

The "complete high fidelity home music center."



In New York hear "Accent on Sound" with Skip Weshner, WBAI-FM, week nights, 9 P.M. In Los Angeles, KRHM-FM, 10 P. M.

# AUDIOCLINIC??

JOSEPH GIOVANELLI\*

## Do you know what "frequency response" really means?

You do know, of course, that it's a measure of acoustical performance—an indication of how high your Hi-Fi really is. But are you on speaking terms with the "plus or minus 2 db" that goes with it?

The frequency response of a tape recorder tells you the highest and lowest sound frequencies that it will reproduce well. And the "db" reference specifies "how well." This measure is based on the decibel (db)—a unit which corresponds to the ear's ability to distinguish changes in sound intensity. A change of 1 db is barely perceptible to an expert under ideal conditions. Three db is just noticeable under ordinary conditions.

If a machine has a response of 30–15,000 cps ( $\pm 2$  db), the output will not vary more than a total of 4 db throughout this frequency range. This is very good performance, usually found only in professional type equipment.

Magnetic tape, too, has its own frequency limitations. But in a good tape these response limits are usually well beyond the range of the machine. However, not all tapes have exactly the same degree of response at all frequencies. For highest fidelity, tape response should be as nearly *uniform* as possible at all audible frequencies. Audiotape is especially formulated to give you the *balanced response* so necessary for true-to-life sound reproduction.

If you're a serious tape fan, you'll be interested in "How to Make Good Tape Recordings"—a 150-page book which gives you all the answers. For an attractive free folder describing the book, write for Bulletin T. Audio Devices, Inc., Dept. AA, 444 Madison Avenue, New York 22, N. Y.

### Spurious Response in Recorders

*Q. When a high frequency sine wave is recorded and played back through the recorder, a spurious response is heard which increases in strength in proportion to the fundamental, when the recording signal strength is increased. The frequency at which this phenomenon begins depends upon the quality of the recorder, and I have heard it start at 10,000 to 15,000 cps. I'm rather doubtful that this is a heterodyne effect occurring between the bias oscillator and the input signal, since I heard a response of estimated 5000 cps in addition to the 15,000-cps sine wave tone fed into the machine's input, when recorded on an Ampex 601, which has a bias frequency of 100 kc. If this were a heterodyning effect it would require approximately a sixth harmonic of the 15,000-cps input signal to combine with the bias frequency to give even a 10,000-cps spurious response, which seems unlikely. What is your explanation of this phenomenon? Burton W. Byler, Oreland, Pa.*

*A. The 5000-cps tone you hear when a 15,000-cps signal is fed into the tape recorder is caused by the combining of a harmonic of this tone with the bias frequency. Despite the fact that the oscillation fed into the machine is a pure sine wave, harmonics may nevertheless be generated. The greater the level of the recording signal, the greater the harmonic distortion generated within the recording amplifier, and at the head where the signal is mixed with the bias. The bias frequency, furthermore, is only approximate. It is not at all impossible for it to be either 95 or 110 kc rather than the specified 100 kc. These frequencies can heterodyne with either the sixth or seventh harmonic, with the resultant 5 kc tone you have observed. It is also possible for the audio oscillator to be inexact as to frequency. A little figuring will show that an error of slightly less than a kilocycle can produce sufficient error at the sixth harmonic to cause the 5-kc tone, assuming that the bias frequency is exact.*

Should you wish to determine precisely the frequency of the bias oscillator, couple some of its signal into the antenna terminals of a standard broadcast receiver, being careful not to introduce d.c. into the antenna coil. You will observe that a beat will occur at several places on the dial. This beat is caused by a harmonic of the oscillator combining with one of the stations. Where there is no station to beat against, the bias oscillator signal will appear as an unmodulated carrier. The frequency separating the appearances of successive signals from the oscillator is determined by the frequency separation of two successive harmonics, which, in turn, is equal to the fundamental frequency of the bias oscillator. The more accurately calibrated your receiver dial is, the more

accurately the frequency of the bias oscillator can be determined. Of course, when two successive harmonics of the bias signal beat with two broadcast stations each of whose frequency is known and when each of the beat frequencies resulting from said combination is known, the exact bias frequency can be obtained without accurate receiver dial readings.

### Tape Hiss

*Q. What is the exact cause of tape hiss? This objectionable noise is present on many recorded tapes and even on some professionally-recorded original tapes. Burton W. Byler, Oreland, Pa.*

*A. There are two basic causes: 1) The recording amplifier may contain tube and resistor noise whose volume is sufficient to cause it to be recorded on the tape in the form of hiss. 2) Magnetic tape may be considered to be composed of an almost infinite number of minute magnets. The number of these whose polarity and strength is used determines the nature of the recorded material. Some of the magnets are not used; their poles are aligned in a helter-skelter manner. Because this alignment is non-uniform, it is obvious that small random groups of molecules will be aligned in the same direction, thereby combining to form larger magnets whose strengths are sufficient to cause voltages to be developed as the tape is being reproduced. These voltages are heard as hiss.*

### Remote Cartridge Circuit

*Q. My layout is such that I keep by Kodine hysteresis motor and Pickering cartridge in another room, quite removed from the amplifier. As the leads are fairly long, I fear considerable loss of highs in the shielded cable. Could you suggest a simple circuit using, perhaps, a 12AY7, with one stage of flat amplification and a cathode follower stage using d.c. on the heaters? Frank Gittelson, Lynbrook, N. Y.*

*A. Figure 1 should solve your problem.*

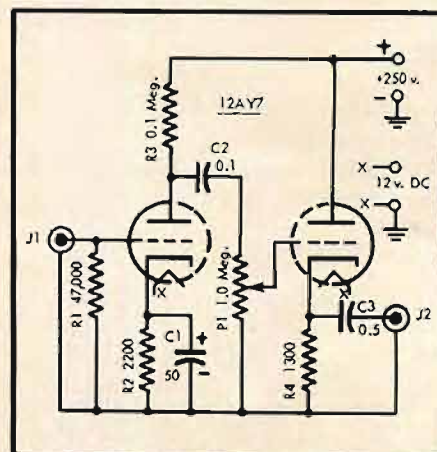

Figure 1

\* one of a series

\* 3420 Newkirk Ave., Brooklyn 5, N. Y.

Garrard models change. Garrard ideals do not. Meaningful new features are added. Time-proven features are carefully retained. Gadgets, for the sake of gadgetry, are sternly rejected. The all-important fact to remember is that thirty-five years of experience in designing, testing, and building fine record players, guide us in offering you the present Garrard models.

# Garrard

**WORLD'S FINEST  
RECORD PLAYING  
EQUIPMENT**



*There's a Garrard for every high fidelity system*



**Model 301 PROFESSIONAL  
TRANSCRIPTION TURNTABLE**  
Each speed variable!  
Each unit with its own  
performance test report. \$89.00



**Model RC98 4-SPEED SUPER  
AUTO-MANUAL CHANGER**  
Continuous  $\pm$  or  $-$  variable  
control on all speeds. \$67.50

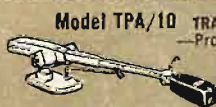

**Model TPA/10 TRANSCRIPTION TONE ARM**  
—Professional performance,  
jewel-like construction  
and exceptional  
versatility. \$24.50



**Model RC88 4-SPEED DELUXE  
AUTO-MANUAL CHANGER**  
Exclusive pusher platform  
protects your records. \$54.50



**Model T Mark II  
4-SPEED MANUAL PLAYER**  
A superior unit for quality  
budget systems. \$32.50



**Model RC121 4-SPEED MIXER  
AUTO-MANUAL CHANGER**  
Fine performance with economy  
and compactness. \$42.50

**GARRARD SALES CORPORATION, Dept. GB18, PORT WASHINGTON, N. Y.**

# COMING

## To Your City . . .

### HIGH FIDELITY SHOWS

SEE and HEAR the latest in HIGH FIDELITY from leading high fidelity manufacturers . . .

Don't miss these public showings of Hi-Fi Equipment . . . from the most economical units for the budget-minded to spectacular home music theatres . . . compare and enjoy them all.

\*Complete Hi-Fi Systems and Components.

\*Amplifiers — Pre-Amplifiers — FM-AM Tuners — Turntables and Record Changers — Phono Cartridges — Microphones — Music Control Centers — Speakers.

\*Speaker Enclosures and Equipment Cabinets — Finished and Assembled or Do-It-Yourself Kits.

THREE FULL DAYS OF CONTINUOUS DEMONSTRATIONS  
FROM 1 P.M. TO 10 P.M. FOR EACH SHOW

#### Rigo Spring Shows 1958

|                  |            |                      |
|------------------|------------|----------------------|
| Feb. 7, 8, 9     | Denver     | Hotel Cosmopolitan   |
| March 7, 8, 9    | Pittsburgh | Hotel Penn-Sheraton  |
| March 21, 22, 23 | Newark     | Hotel Robert Treat   |
| March 28, 29, 30 | Baltimore  | Hotel Lord Baltimore |

ADMISSION 50¢

**RIGO Enterprises Inc.** 500 N. Dearborn, Chicago 10, Ill.

The circuit employs a 12AY7, chosen because of its low noise content. It is used as a voltage amplifier and cathode follower output. Thus, the pickup is presented with its proper impedance and the output impedance is sufficiently low to enable the use of lines up to 50 ft. in length or even more, without serious high frequency degradation. Because of the possibility of overloading your preamplifier, a volume control was incorporated in the cathode follower stage to limit the signal feeding the preamplifier to a level somewhere below the fold-up point. The circuit is designed to operate with approximately 250 volts on the plates. Since the plate and filament supplies for this circuit are entirely conventional, they are not shown. This circuit may also be used to feed other high-impedance devices into the preamplifier. Care must be taken not to overload the 12AY7 and means must be provided for adjusting the value of the input resistor, should the output impedance of the device used be in excess of 47,000 ohms.

#### Acoustical Feedback and Decoupling

*Q. Please give me your suggestions and comments regarding difficulty I am having with the following equipment: Miracord XA100 with cartridge, Eico HF61A master control preamplifier, Eico HF60 amplifier, AR1 speaker system. With the input adjustment on the main amplifier set at approximately midway and the bass boost on the preamplifier at or about maximum, a low-frequency oscillation will be set up either by a low-frequency transient or by a light tap on the record player spindle. This oscillation continues until the line current is switched off for several seconds. The oscillation is in the range of 20-25 cps. Voltages and resistances check out in accordance with Eico instructions. From my check on the equipment, it is almost a certainty that the difficulty is with the preamplifier. W. H. Focht, Tipp City, Ohio.*

*A. From your letter, it seems clear that this difficulty occurs only when a record is being played at the time this oscillation is taking place. It is likely that the oscillation is caused by acoustical feedback. To eliminate this condition, the speaker must be moved further from the equipment cabinet, or the record changer must be isolated from the equipment cabinet by some kind of shock absorber. In the event that a record is not being played, it is likely that there is insufficient decoupling capacitance between amplifier and preamplifier circuits or within these units themselves.*

Lack of decoupling does not always indicate reduced capacitance of the decoupling capacitors. It might be that the main filter capacitors in the power supply are defective, perhaps not to the point where hum makes its appearance, but sufficiently to raise the impedance of the power supply to a point where the power supply can become a common coupling agent between all circuits.

#### Infinite Baffles

*Q. Among the objections to the infinite baffle type of enclosure is that the pressure built up inside the cabinet by cone travel interferes with free operation of the*  
*(Continued on page 6)*



# SONORAMIC

## THE QUALITY RECORDING TAPE IN THE NEW PERMANENT PLASTIC CONTAINER

Sure, Sonoramic might cost a few pennies more. *But*—it buys you the unique protection and convenience of Sonoramic's new permanent plastic container.

This exclusive product is a high impact, shatter-proof, polystyrene box styled in a handsome slote gray. The container protects tape against dust and dirt; opens at the flick of a finger; stacks neatly side by side on shelf, bookcase, table or can be mounted on a wall. It also comes with a handy indexing system on pressure-sensitive labels which is keyed to the unique Ferrodynamic's *Selection Finder* reel.

More important—the box holds Sonoramic's new wide latitude recording tape.

This tape is a giant step forward in recording tape engineering. It guarantees the user distortion-free recording and maximum performance regardless of make of recorder, line voltage fluctuations and tube age and head condition. Lubricated-for-a-lifetime too, to eliminate squeal, layer-to-layer adhesion and deposits on heads.

Feature of the new Sonoramic line is the Ten-silized Double-Play Mylar\*—2400 feet on a 7" reel—which is twice as strong as ordinary magnetic tapes with the same playing time. Whatever your tape needs—for the home or for professional use—you'll find a Sonoramic tape to fit your needs.

For extra convenience, and at no extra cost, the tape comes in the exclusive Ferrodynamic's easy-to-thread V-slot *Selection Finder* reel.

\*A Du Pont trademark.

*To the first 50 people who respond to this advertisement—we'll be happy to send out a free Sonoramic tape container. (And if you're not in the first 50, we've a pleasant surprise for you anyhow.) Write to Dept. A-103, Ferrodynamic's Corporation, Lodi, New Jersey.*

SONORAMIC IS A PRODUCT OF THE

 **ferrodynamic's** CORPORATION  
LODI, NEW JERSEY

the  
miracle  
cartridge  
that  
**LOCKS OUT HUM**

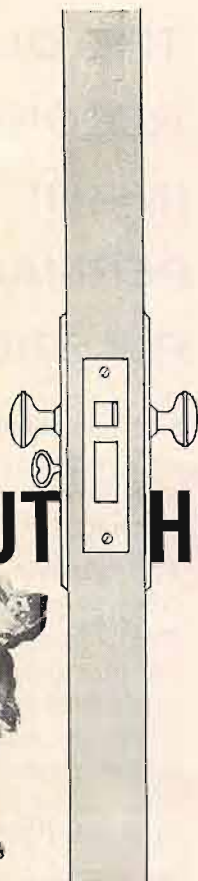

HUM  
HUM

## MIRATWIN

MIRATWIN is as smooth and sensitive a cartridge as man can make. It faithfully transmits the *complete* recorded sound. And it is the most perfectly-shielded cartridge made . . . to entirely eliminate hum! So, if you have a hi-fi system, bring out its finest tonal values with MIRATWIN. Fits all standard tone arms, has instant stylus replacement.

**MIRATWIN mst-1 single**  
with diamond stylus for LP  
or standard diamond stylus

Formerly \$34.50 **NOW \$26.50**

**MIRATWIN mst-2 turnover**  
with sapphire stylus for standard and  
diamond stylus for microgroove

Formerly \$45.00 **NOW \$31.50**

TRANSIENT RESPONSE UNSURPASSED — within 2 db from 30 to over 20,000 cycles at 33 1/4 rpm. OUTPUT — at 1,000 cycles, 55 mv for 33 1/4 rpm; 45 mv for 78 rpm at a recorded velocity of 10 cm/sec., a great improvement in signal-to-noise ratio. DISTORTION — one of the lowest ever achieved in a cartridge. HUM—high output actually produces a 6 to 8 db improvement in hum ratio of associated amplifiers. MAGNETIC PULL — too small to measure with either magnetic or non-magnetic turntables. TRACKING — perfect even at very high

amplitude peaks with all speeds. NEEDLE CHATTER — completely negative; probably the lowest ever achieved. MOUNTING — unusually simple. TROPICALIZED: MIRATWIN cartridges are especially treated to remain unaffected by temperature and humidity changes; maintain their excellence of performance anywhere. PLUS...the easiest stylus replacement you've ever seen . . . good reason why an independent testing laboratory stated that the new MIRATWIN "exceeds its own specifications"! Complete with holder for quick installation.

### MIRATWIN CARTRIDGES

MST-1D Single Diamond \_\_\_\_\_ \$26.50  
MST-1S Single Sapphire \_\_\_\_\_ 10.00  
MST-2D Dual-1 Sapph., 1 Diam. \_\_\_\_\_ 31.50  
MST-2A Dual Sapphire \_\_\_\_\_ 15.00

### REPLACEMENT STYLI

DM-2 Micro-Diamond \_\_\_\_\_ \$16.50  
DN-2 Standard Diamond \_\_\_\_\_ 16.50  
SM-2 Micro-Sapphire \_\_\_\_\_ 5.00  
SN-2 Standard Sapphire \_\_\_\_\_ 3.00



mst-1



mst-2

## LETTERS

### Clarification

Sir:

I have been reading with much interest the comments by Mr. Canby in the December issue of AUDIO, but I am afraid that some of his comments about our soft-surround speakers are not quite in accordance with fact.

We changed over from cloth to foam surrounds in May, 1956, not because our expert builders were old and decrepit, but because we found that *correct* foam suspension gave superior results from practically every point of view. Other things being equal, the bass resonance is lower, the dissipation of high frequencies at the edge of the cone is better, and the elevation of the cone assembly is more accurately maintained after a long period of use. Furthermore, the foam plastic is not subject to attack by moths and other insects.

Before making the change we spent months in experimenting and establishing the best thickness and consistency in the foam. Our requirements here are so stringent that all the foam we use is specially made for us, and as yet only one firm in this country is willing and able to supply this special material. We also had to find suitable adhesives and learn how to apply them. Much time was spent on this problem alone.

As regards our skilled hands, to whom Mr. Canby alluded, our chief expert is Mr. E. R. Broadley who has been with us 25 years, but he is still only 46 years of age!

Mr. Canby said that we were in the habit of cutting out the cloth segments by hand, but this was not the case. They were all accurately stamped out by cutters, but the assembly work was done by hand in exactly the same method that is adopted with foam surround.

G. A. BRIGGS,

Wharfedale Wireless Works,

Bradford, Idle, Works., England

(Literary license, no doubt—at least we never let the facts stand in the way of a good story. Ed.)

### Transistor Symbols

Sir:

Somewhat remote from the subject of transistor symbols mentioned in an EDITOR'S REPORT and in LETTERS (I am quite happy with the ones Mr. Penfield uses) is the matter of type designation.

I suggest that in the type number, the second character (now the letter "N") be used to designate whether the unit is NPN or PNP. Thus, for example, the 2N170—a PNP transistor—would be changed to 2P170; the 2N173—an NPN unit—would remain 2N173.

It is not too late to make this change, but it is likely to be if it is delayed very long.

I believe that in the long run the system would be worthwhile and sufficiently useful to counterbalance the temporary inconvenience of changing designations.

ROBERT K. DAVIS,

4111 Pleasant Run Blvd. So. Dr.,  
Indianapolis 1, Ind.



**AUDIOGERSH CORP.** 514 Broadway, New York 12, N. Y.

WORTH 6-0800



### EF86 6Z6

Exceptionally low hum, low microphony and low noise tube. Specially designed for input stages of high sensitivity in high quality equipment.



### ECC83 12AX7

Double triode with especially good microphony performance and high gain. Used in equipments where utmost versatility is required.



### EL84 6BQ5

Economical, high sensitivity output pentode. Of miniature all-glass construction on the noval base. Two tubes in push-pull can provide 17W output for only 20V drive (grid-to-grid).

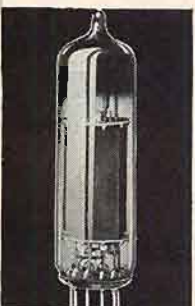

### EL34 6CA7

High sensitivity 25W pentode. Two tubes in ultralinear push-pull provide up to 40W output. For public address work, two tubes in push-pull can supply up to 100W of audio power.

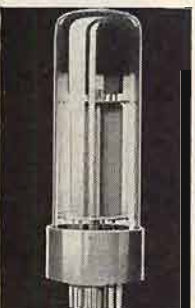

### EZ81 6CA4

Compact full-wave rectifier of miniature all-glass construction on noval base. Provides up to about 350V output at 150mA with good regulation.



### GZ34 5AR4

Modern full-wave rectifier supplying up to 600V at 160mA, or 450V at 250mA with good regulation. Recommended for the larger type of Hi-Fi equipment.

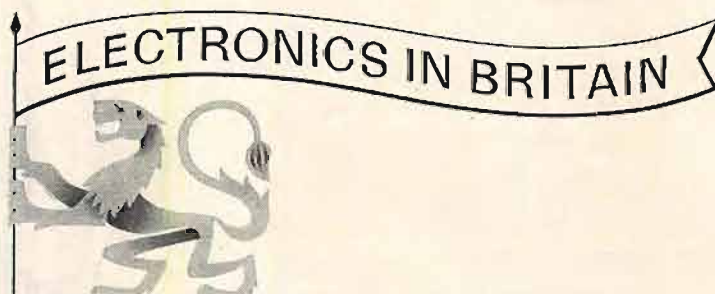

## 6 sound investments

The Mullard range of audio tubes has won universal acclaim among high fidelity sound experts: and it is easy to understand why. Every single tube in this range has been specially developed to meet the exacting needs of sound reproduction. Read the specifications left; see for yourself what makes each tube such a sound investment.

#### Supplies available from:

##### in the U.S.A.

International Electronics Corporation,  
Dept. A2, 81, Spring Street, N.Y. 12,  
New York, U.S.A.

##### in Canada

Rogers Majestic Electronics Limited,  
Dept. HB, 11-19 Brentcliffe Road,  
Toronto 17,  
Ontario, Canada.

# Mullard

## ELECTRONIC TUBES

*used throughout the world*

MULLARD OVERSEAS LTD., MULLARD HOUSE,  
TORRINGTON PLACE, LONDON, ENGLAND.

*Mullard is the Trade Mark of Mullard Limited and is registered in most of the principal countries of the world.*



easy-to-build

high quality

# HEATHKITS®

**Look** . . . how simply you can assemble your very own high fidelity system! Fun-filled hours of shared pleasure, and an everlasting sense of personal accomplishment are just a few of the rewards. Heathkits cost you only HALF as much as ordinary equipment and the quality is unexcelled. Let us show you how easy it really is! . . .



✓ Install a .001 µfd disc condenser from socket B7 (NS) to ground lug B11 (NS). Cut the leads so that they are just long enough to reach and dress the condenser close to chassis, over the wires already present.

( ) Connect a 470 KΩ resistor (yellow-violet-yellow) from socket B7 (S) (2) to B8 (NS). Mount as close to the socket as possible.

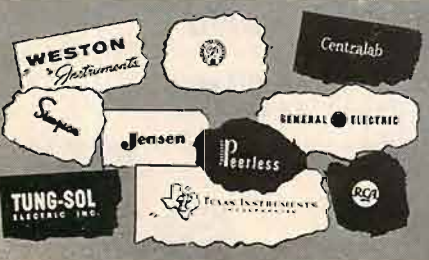
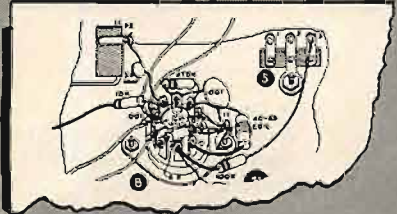

### Step-by-Step Assembly Instructions . . .

Read the step . . . perform the operation . . . and check it off—it's just that simple! These plainly-worded, easy-to-follow steps cover every assembly operation.

### Easy-to-follow Pictorial Diagrams . . .

Detailed pictorial diagrams in your Heathkit construction manual show where each and every wire and part is to be placed.

### Learn-by-doing Experience For All Ages . . .

Kit construction is not only fun—but it is educational too! You learn about radio, electronic parts and circuits as you build your own equipment.

### Top Quality Name-Brand Components Used in All Kits . . .

Electronic components used in Heathkits come from well-known manufacturers with established reputations. Your assurance of long life and trouble-free service.



HEATHKIT

## bookshelf 12-watt amplifier kit

# NEW

MODEL EA-2  
**\$25<sup>95</sup>**

There are many reasons why this attractive amplifier is a tremendous dollar value. You get many extras not expected at this price level. Rich, full range, high fidelity sound reproduction with low distortion and noise . . . plus "modern" styling, making it suitable for use in the open, on a bookcase, or end table. Look at the features offered by the model EA-2: full range frequency response (20--20,000 CPS ± 1 db) with less than 1% distortion over this range at full 12 watt output—its own built-in preamplifier with provision for three separate inputs, mag phono, crystal phono, and tuner—RIAA equalization—separate bass and treble tone controls—special hum control—and it's easy-to-build. Complete instructions and pictorial diagrams show where every part goes. Cabinet shell has smooth leather texture in black with inlaid gold design. Front panel features brushed gold trim and buff knobs with gold inserts. For a real sound thrill the EA-2 will more than meet your expectations. Shpg. Wt. 15 lbs.

**TIME PAYMENTS AVAILABLE  
ON ALL HEATHKITS  
WRITE FOR FULL DETAILS**



## chairside enclosure kit

# NEW

This beautiful equipment enclosure will make your hi-fi system as attractive as any factory-built professionally-finished unit. Smartly designed for maximum flexibility and compactness consistent with attractive appearance, this enclosure is intended to house the AM and FM tuners (BC-1A and FM-3A) and the WA-P2 preamplifier, along with the majority of record changers, which will fit in the space provided. Adequate space is also provided for any of the Heathkit amplifiers designed to operate with the WA-P2. During construction the tilt-out shelf and lift-top lid can be installed on either right or left side as desired. Cabinet is constructed of sturdy, veneer-surfaced furniture-grade plywood  $\frac{1}{2}$ " and  $\frac{3}{4}$ " thick. All parts are pre-cut and pre-drilled for easy assembly. Contemporary available in birch or mahogany, traditional in mahogany only. Beautiful hardware supplied to match each style. Dimensions are 18" W x 24" H x 35 $\frac{1}{2}$ " D. Shpg. Wt. 46 lbs.



CE-1C Mahogany  
CE-1CB Birch

CONTEMPORARY



CE-1T Mahogany

TRADITIONAL

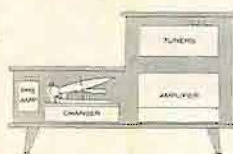

Be sure to specify model you prefer

**\$43<sup>95</sup>**  
each



HEATHKIT

### high fidelity FM tuner kit

For noise and static free sound reception, this FM tuner is your least expensive source of high fidelity material. Efficient circuit design features stabilized oscillator circuit to eliminate drift after warm-up and broadband IF circuits assure full fidelity with high sensitivity. All tunable components are prealigned so it is ready for operation as soon as construction is completed. The edge-illuminated slide rule dial is clearly numbered for easy tuning. Covers complete FM band from 88 to 108 mc. Shpg. Wt. 8 lbs.

**MODEL FM-3A \$25.95 (with cabinet)**



HEATHKIT

### broadband AM tuner kit

This tuner differs from an ordinary AM radio in that it has been designed especially for high fidelity. A special detector is incorporated and the IF circuits are "broadbanded" for low signal distortion. Sensitivity and selectivity are excellent and quiet performance is assured by a high signal-to-noise ratio. All tunable components are prealigned before shipment. Incorporates automatic volume control, two outputs, and two antenna inputs. An edge-lighted glass slide rule dial allows easy tuning. Your "best buy" in an AM tuner. Shpg. Wt. 9 lbs.

**MODEL BC-1A \$25.95 (with cabinet)**

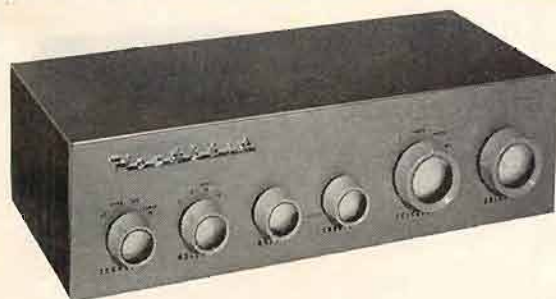

HEATHKIT

### master control preamplifier kit

Designed as the "master control" for use with any of the Heathkit Williamson-type amplifiers, the WA-P2 provides the necessary compensation, tone, and volume controls to properly amplify and condition a signal before sending it to the amplifier. Extended frequency response of  $\pm 1\frac{1}{2}$  db from 15 to 35,000 CPS will do full justice to the finest program material. Features equalization for LP, RIAA, AES, and early 78 records. Five switch-selected inputs with separate level controls. Separate bass and treble controls, and volume control on front panel. Very attractively styled, and an exceptional dollar value. Shpg. Wt. 7 lbs.

**MODEL WA-P2 \$19.75 (with cabinet)**

pioneer in  
"do-it-yourself"  
electronics

 a subsidiary of Daystrom, Inc.

**HEATH**

**COMPANY** • BENTON HARBOR 25, MICHIGAN



**HEATHKIT 25-WATT**

MODEL W-5M

**\$59<sup>75</sup>**



**HEATHKIT 70-WATT**

MODEL W-6M

**\$109<sup>95</sup>**

**high fidelity amplifier kits**

To provide you with an amplifier of top-flight performance, yet at the lowest possible cost, Heath has combined the latest design techniques with the highest quality materials to bring you the W-5M. As a critical listener you will thrill to the near-distortionless reproduction from one of the most outstanding high fidelity amplifiers available today. The high peak-power handling capabilities of the W-5M guarantee you faithful reproduction with any high fidelity system. The W-5M is a must if you desire quality plus economy! Note: Heathkit WA-P2 preamplifier recommended. Shpg. Wt. 31 lbs.

For an amplifier of increased power to keep pace with the growing capacities of your high fidelity system, Heath provides you with the Heathkit W-6M. Recognizing that as loud speaker systems improve and versatility in recordings approach a dynamic range close to the concert hall itself, Heath brings to you an amplifier capable of supplying plenty of reserve power without distortion. If you are looking for a high powered amplifier of outstanding quality, yet at a price well within your reach, the W-6M is for you! Note: Heathkit model WA-P2 preamplifier recommended. Shpg. Wt. 52 lbs.

**HEATHKIT DUAL-CHASSIS**

MODEL W3-AM

**\$49<sup>75</sup>**



**HEATHKIT SINGLE-CHASSIS**

MODEL W4-AM

**\$39<sup>75</sup>**



**high fidelity amplifier kits**

One of the greatest developments in modern hi-fi reproduction was the advent of the Williamson amplifier circuit. Now Heath offers you a 20-watt amplifier incorporating all of the advantages of Williamson circuit simplicity with a quality of performance considered by many to surpass the original Williamson. Affording you flexibility in custom installations, the W3-AM power supply and amplifier stages are on separate chassis allowing them to be mounted side by side or one above the other as you desire. Here is a low cost amplifier of ideal versatility. Shpg. Wt. 29 lbs.

In his search for the "perfect" amplifier, Williamson brought to the world a now-famous circuit which, after eight years, still accounts for by far the largest percentage of power amplifiers in use today. Heath brings to you in the W4-AM a 20-watt amplifier incorporating all the improvements resulting from this unequalled background. Thousands of satisfied users of the Heathkit Williamson-type amplifiers are amazed by its outstanding performance. For many pleasure-filled hours of listening enjoyment this Heathkit is hard to beat. Shpg. Wt. 28 lbs.

**HEATHKIT**

**high fidelity amplifier kit**

MODEL A-9C **\$35<sup>50</sup>**



For maximum performance and versatility at the lowest possible cost the Heathkit model A-9C 20-watt audio amplifier offers you a tremendous hi-fi value. Whether for your home installation or public address requirements this power-packed kit answers every need and contains many features unusual in instruments of this price range. The preamplifier, main amplifier and power supply are all on one chassis providing a very compact and economical package. A very inexpensive way to start you on the road to true hi-fi enjoyment. Shpg. Wt. 23 lbs.

**HEATHKIT**

**electronic crossover kit**

MODEL XO-1 **\$18<sup>95</sup>**



One of the most exciting improvements you can make in your hi-fi system is the addition of this Heathkit Crossover model XO-1. This unique kit separates high and low frequencies and feeds them through two amplifiers into separate speakers. Because of its location ahead of the main amplifiers, IM distortion and matching problems are virtually eliminated. Crossover frequencies for each channel are 100, 200, 400, 700, 1200, 2000 and 3500 CPS. Amazing versatility at a moderate cost. Note: Not for use with Heathkit Legato Speaker System. Shpg. Wt. 6 lbs.



**HEATHKIT "LEGATO"**

## high fidelity speaker system kit

Wrap yourself in a blanket of high fidelity music in its true form. Thrill to sparkling treble tones, rich, resonant bass chords or the spine-tingling clash of percussion instruments in this masterpiece of sound reproduction. In the creation of the Legato no stone has been left unturned to bring you near-perfection in performance and sheer beauty of style. The secret of the Legato's phenomenal success is its unique balance of sound. The careful phasing of high and low frequency drivers takes you on a melodic toboggan ride from the heights of 20,000 CPS into the low 20's without the slightest bump or fade along the way. The elegant simplicity of style will complement your furnishings in any part of the home. No electronic know-how, no woodworking experience required for construction. Just follow clearly illustrated step-by-step instructions. We are proud to present the Legato—we know you will be proud to own it! Shpg. Wt. 195 lbs.

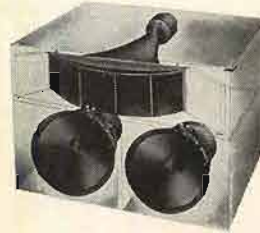

MODEL HH-1-C  
(imported white birch)  
MODEL HH-1-CM  
(African mahogany)

**\$325<sup>00</sup>** each



**HEATHKIT  
BASIC RANGE**

**HEATHKIT  
RANGE EXTENDING**

## high fidelity speaker system kits

MODEL **\$39<sup>95</sup>**  
SS-1

A truly outstanding performer for its size, the Heathkit model SS-1 provides you with an excellent basic high fidelity speaker system. The use of an 8" mid-range woofer and a high frequency speaker with flared horn enclosed in an especially designed cabinet allows you to enjoy a quality instrument at a very low cost. Can be used with the Heathkit "range extending" (SS-1B) speaker system. Easily assembled cabinet is made of veneer-surfaced furniture-grade 1/2" plywood. Impedance 16 ohms. Shpg. Wt. 25 lbs.

Designed to supply very high and very low frequencies to fill out the response of the basic (SS-1) speaker, this speaker system extends the range of your listening pleasure to practically the entire range of the audio scale. Giving the appearance of a single piece of furniture the two speakers together provide a superbly integrated four speaker system. Impedance 16 ohms. Shpg. Wt. 80 lbs.



MODEL **\$99<sup>95</sup>**  
SS-1B

## Free Catalog!

Don't deprive yourself of the thrill of high fidelity or the pleasure of building your own equipment any longer. Our free catalog lists our entire line of kits with complete schematics and specifications. Send for it today!



### NEW! "DOWN-TO-EARTH" HIGH FIDELITY BOOK

THE HOW AND WHY OF HIGH FIDELITY, by Milton Sleeper, explains what high fidelity is, and how you can select and plan your own system. This liberally-illustrated, 48-page book tells you the HI-FI story without fancy technical jargon or high-sounding terminology. **25c**



**HEATH**

pioneer in  
"do-it-yourself"  
electronics

**COMPANY • BENTON HARBOR 25, MICHIGAN**



a subsidiary of Daystrom, Inc.

- Please send the Free HEATHKIT catalog.  
 Enclosed is 25c for the New HI-FI book.

name \_\_\_\_\_

address \_\_\_\_\_

city & state \_\_\_\_\_

ALSO SEND THE FOLLOWING KITS:

| QUANTITY | ITEM | MODEL NO. | PRICE |
|----------|------|-----------|-------|
|          |      |           |       |
|          |      |           |       |
|          |      |           |       |

Enclosed find \$..... Please enclose postage for parcel post—express orders are shipped delivery charges collect. All prices F.O.B. Benton Harbor, Mich. NOTE: Prices subject to change without notice.

# AUDIO ETC.

Edward Tatnall Canby

## 1. ALL-TRANSISTOR

For some time now I've been listening to 20 full watts worth of hi-fi without a single tube of any sort.

It's a strange sensation, this, after some thirty-odd years of vacuum tube phonograph sound—but here I am, quite tubeless, and yet the house is filled with music as loud as you could ever want, out of a little black box the size of most control units. It is the Vico all-transistor home amplifier, model 77, made in Los Angeles by the Video Instrument Co., sent to me for try-out. I am indeed impressed, though I have some external reservations about this particular model which I'll get to in a moment.

Ever since I tried out an all-transistor battery phono preamp (Fisher) last year—and used it for months and months on one small battery as an emergency mike preamplifier, low-impedance—I've been wondering how long it would take for somebody to design enough circuitry to go the whole hog and provide a production power amplifier as well, with controls. It came sooner than I would have guessed and, I suspect, this Vico model points the course of much future home amplifier design.

Transistors are certainly odd, after you have been taking tubes for granted for years and years. You are instantly aware, when you hook up this amplifier, that this is a new and strange breed of hi-fi. It doesn't look like an amplifier and it doesn't act like one at all, except to provide the essential 20 watts of undistorted output. For one thing, the Vico runs virtually stone cold—and is *that* a strange sensation. One very weak pilot light is the only major heat source and after an hour or so the perforated metal box is barely warm. Along with this is instant starting—the Vico takes off at full power about a half second after you flip the switch. No warm up.

You can appreciate the full meaning of transistor circuitry when you find that this 20-watt amplifier draws a total of about 7 watts from the power line when it is at rest—not amplifying. Some of that goes to the small pilot light, too. No heaters, no continuous current flow, no heat. At the full 20-watt output the input is only 30 watts. This would seem to be about as near to ideal efficiency as we can ever hope to get. Now if we just had a loudspeaker with similar efficiency, we could fill a stadium with sound from this one source.

"No-tubes, no-hum," says the Vico folder. Well, not quite as simple as that. The amplifier will amplify any hum that gets into it, just like any conventional model, and so shielding and the like is the same old problem, never quite licked to perfection in most home systems. I got very little hum on my radio connection and a bit less on the phono—virtually none at all. The specs say hum is better than 100 db below 20 watts output. There is a transformer in the amplifier, stepping down line current to

feed a rectifier that delivers 12 volts d.c. Could radiate a tiny bit of hum and I thought my ear caught a trace—but it is certainly extremely low, lower than in any of the amplifiers I have sitting around at the moment.

However, transistors do tend to sputter and hiss a bit. I seem to notice this in the Vico especially during the "warm-up" period, if the term can be used. My transistor preamp also produced this sort of noise and it may be a minor problem to come in home equipment; it is not a pleasing sound, though better than its equivalent in hum. A quiet fried-egg effect.

The Vico output is interesting. No transformer but instead an autotransformer—first time I'd run into the term myself. One coil, with taps on it. The end result is the same old thing, standard output at the usual ohm ratings. Evidently one must be careful not to overload things at this part of the circuit; it is unwise to plug inputs in or out with the speaker leads unconnected. Also the transistor circuits must be very carefully protected from heat—hence the very feeble pilot light. Evidently heat even as slight as that from a hot miniature bulb can do harm. But since the transistors don't produce much of their own heat the practical problem is quite different from the usual one with power amplifiers; confined spaces aren't as risky but warm radiators, hot lamp bulbs—even sunlight on a hot day, are potential dangers.

The use of perforated metal material, full of thousands of holes, was a wise idea in the housing of the Vico, as well as a decorative one. Both ventilation and heat radiation are at maximum.

So far so good. The Vico sound, tested purely by ear, is all that could be desired. I noticed, incidentally, that transistors are subtly different even in the sound of their distortion—the overload sound (from a too-high input) is distinctly unlike that in the usual tube amplifier. What the difference in wave shape is I do not know—the distortion has a peculiarly wooden sound that I already associate with transistor circuits. When things are operating normally the sound is like any other high-quality reproduction.

How did I come across the overload distortion? That brings me to the slightly negative aspect of this account that has to do with the outward controls and general facilities of the Vico transistor amplifier. They are a good way from my conception of right and proper.

Now I have no idea at all what sort of problems might or might not arise in designing standard facilities such as variable tone controls—bass and treble—equalization curves for records, preamplification at the proper levels, and so on. It may be agonizingly hard, or impossible, to design a tone control to match the usual type now standard on our tube-style amplifiers. Maybe it's easy. I can only report on the externals of this Vico model.

1. The bass tone control is flat at about the "nine o'clock" position, unmarked, gives a healthy boost but a very slight rolloff. Until I discovered this in the typed instructions I had incomprehensibly boomy and too-loud bass.

2. The treble tone control is nominally flat at the straight-up point but seemed to me to be flattest at about one o'clock. More important, the rolloff taper is radically wrong—practically nothing happens on the right half of the range and on down into the left (rolloff) area, then the entire action comes suddenly.

3. There are six equalization positions for records but several of them seemed to me remarkably alike if not identical. I might be wrong.

4. A serious fault—the volume control is a compensated loudness control and *there is no way to disconnect the compensation*; and *there are no input level-sets*, to adjust the control to incoming level and to room situation.

These two together, plus that which follows, make the amplifier grotesquely unusable in many situations. With no level-sets, incoming signals can be adjusted *only* by the loudness control itself, which must be turned down to attenuate them for listening. The result is false compensation, boomy extra bass, and the amplifier can be used only by rolling off the bass tone control—but *there is no bass rolloff* on this amplifier (see the preceding); so you are licked! Not a thing you can do.

5. The high-level inputs are designed to take about one volt, to drive the amplifier to proper output. No level sets. Somebody had the naive idea that most radio tuners and tape recorders produce one volt! Most tuners send out a healthy three or four or five volts. Result: the radio input is absolutely unusable unless you are lucky enough to have an output level-set on the tuner. I did, and I turned it almost all the way down before the signal was attenuated enough to drive the Vico rightly.

I tried to play my Ampex 350 through the Vico and got nothing but hideous blasting at very high overload. The Ampex, too, puts out more than the Vico wants and Ampex does not have an output level control. Its output is more or less standard.

Either something is very wrong with my Vico or somebody did some pretty sketchy investigating into the standard output voltages for common high-level sources in hi-fi.

6. There is a four-position range control or scratch filter; mine is entirely inoperative. (The rumble filter works OK.)

7. The high-level inputs have me baffled. Specs call for HIGH-LEVEL INPUT FOR TAPE but the input plug is marked TAPE HEAD and, as far as I can figure, is low-level. Goes through the preamp. Just to further confuse things, the front control says merely TAPE. And as for the HIGH-LEVEL INPUT FOR CRYSTAL OR CERAMIC PICKUP, it feeds through the complete array of equalization positions for magnetic cartridge, though it by-passes the preamp. This would seem to me to be gilding the lily, to put it mildly! Just what happens to a pre-equalized (inherently equalized) ceramic when it is fed into an RIAA curve-producer? Maybe I'm dumb but I can't figure this one out.

(Nope, this input is not for those de-tuned ceramics that are made to act like magnetics. They plug into the regular magnetic input.)

All of which adds up to a pretty impressive sort of unfinishedness, it would seem.

(Continued on page 48)

the experts say... in High Fidelity the best buys are



**EICO**  
KITS and WIRED

**BETTER ENGINEERING** Since 1945 EICO has pioneered the concept of test instruments in easy-to-build kit form — has become world-famous for laboratory-precision instruments at low cost. Now EICO is applying its vast experience to the creative engineering of high fidelity. Result: high praise from such authorities as Canby of AUDIO, Marshall of AUDIOCRAFT, Holt of HIGH FIDELITY, Fantel of POPULAR ELECTRONICS, Stocklin of RADIO TV NEWS, etc. — as well as from the critical professional engineers in the field.†

**SAVE 50%** Mass purchasing, and a price policy deliberately aimed to encourage mass sales, make this possible.

**EASY INSTRUCTIONS** You need no previous technical or assembly experience to build any EICO kit — the instructions are simple, step-by-step, "beginner-tested."

**DOUBLE 5-WAY GUARANTEE** Both EICO, and your neighborhood distributor, guarantee the parts, instructions, performance . . . as well as lifetime service and calibration at nominal cost . . . for any EICO kit or wired unit.

**BEFORE YOU BUY, COMPARE** At any of 1200 neighborhood EICO distributors coast to coast, you may examine and listen to any EICO component. Compare critically with equipment several times the EICO cost — then you judge. You'll see why the experts recommend EICO, kit or wired, as best buy.

† Thousands of unsolicited testimonials on file.

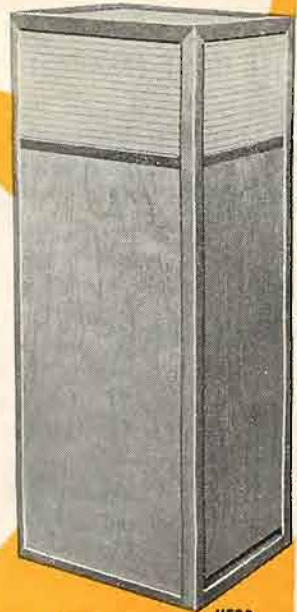

HFS2 Speaker System



HFT90 FM Tuner with "eye-tronic" tuning



HF61 Preamplifier



HF60, HF50 Power Amplifiers



**HFS2 Speaker System:** Uniform loading & natural bass 30-200 cps achieved via slot-loaded split conical bass horn\*\* of 12-ft path. Middles & lower highs from front side of 8½" cone, edge-damped & stiffened for smooth uncolored response. Suspensionless, distortionless spike-shaped super-tweeter\*\* radiates omni-directionally. Flat 45-20,000 cps, useful to 30 cps. 16 ohms. HWD: 36", 15¼", 11½". "... rates as excellent . . . unusually musical . . . really non-directional!" — Canby, AUDIO. "Very impressive" — Marshall (AUDIOCRAFT). Walnut or Mahogany, \$139.95. Blonde, \$144.95.

**HFT90 FM Tuner** equals or surpasses wired tuners up to 3X its cost. New, pre-wired, pre-aligned, temperature-compensated "front end" — drift-free. Sensitivity, 1.5 uv for 20 db quieting, is 6X that of other kit tuners. DM-70 traveling tuning eye. Response 20-20,000 cps ± 1 db. Cathode follower & multiplex outputs. Kit \$39.95\*. Wired \$65.95\*. Cover \$3.95. \*Less cover, excise tax incl.

**HF61A Preamplifier**, providing the most complete control & switching facilities, and the finest design, offered in a kit preamplifier, "... rivals the most expensive preamps . . . is an example of high engineering skill which achieves fine performance with simple means and low cost." — Joseph Marshall, AUDIOCRAFT. HF61A Kit \$24.95, Wired \$37.95, HF61 (with Power Supply) Kit \$29.95, Wired \$44.95.

**HF60 60-Watt Ultra Linear Power Amplifier**, with Acro TO-330 Output Transformer, provides wide bandwidth, virtually absolute stability and flawless transient response. "... is one of the best-performing amplifiers extant; it is obviously an excellent buy." — AUDIOCRAFT Kit Report. Kit \$72.95, Wired \$99.95. Matching Cover E-2 \$4.50.

**HF50 50-Watt Ultra-Linear Power Amplifier** with extremely high quality Chicago Standard Output Transformer. Identical in every other respect to HF60 and same specifications up to 50 watts. Kit \$57.95. Wired \$87.95. Matching Cover E-2 \$4.50.

**HF30 30-Watt Power Amplifier** employs 4-EL84 high power sensitivity output tubes in push-pull parallel, permits Williamson circuit with large feedback & high stability. 2-EZ81 full-wave rectifiers for highly reliable power supply. Unmatched value in medium-power professional amplifiers. Kit \$39.95. Wired \$62.95. Matching Cover E-3 \$3.95.

**HF-32 30-Watt Integrated Amplifier Kit** \$57.95. Wired \$89.95.

**HF52 50-Watt Integrated Amplifier** with complete "front end" facilities and Chicago Standard Output Transformer. Ultra-Linear power amplifier essentially identical to HF50. The least expensive means to the highest audio quality resulting from distortion-free high power, virtually absolute stability, flawless transient response and "front end" versatility. Kit \$68.95. Wired \$109.95. Matching Cover E-1 \$4.50.

**HF20 20-Watt Integrated Amplifier**, complete with finest preamp-control facilities, excellent output transformer that handles 34 watts peak power, plus a full Ultra-Linear Williamson power amplifier circuit. Highly praised by purchasers, it is established as the outstanding value in amplifiers of this class. Kit \$49.95. Wired \$79.95. Matching Cover E-1 \$4.50.

Prices 5% higher in the West

**HF12 12-Watt Integrated Amplifier**, absolutely free of "gimmicks", provides complete "front end" facilities & true fidelity performance of such excellence that we can recommend it for any medium-power high fidelity application. Two HF12's are excellent for stereo, each connecting directly to a tape head with no other electronic equipment required. Kit \$34.95. Wired \$57.95.

**HFS1 Two-Way Speaker System**, complete with factory-built cabinet. Jensen 8" woofer, matching Jensen compression-driver exponential horn tweeter. Smooth clean bass; crisp extended highs. 70-12,000 cps ± 6 db. Capacity 25 w. Impedance 8 ohms. HWD: 11" x 23" x 9". Wiring time 15 min. Price \$39.95.

**MAIL COUPON FOR CATALOG**

EICO® 33-00 Northern Blvd., L.I.C. 1, N.Y.

Show me how to SAVE 50% on professional Test Instruments and High Fidelity. Send me free catalog and name of neighborhood distributor.

Name .....

Address .....

City ..... Zone ..... State ..... A-2

\*\* Patents pending by Hegeman Laboratories



HF52, HF20 Integrated Amplifiers



HF12 Integrated Amplifier



HF30 Power Amplifier



HFS1 Speaker System



33-00 Northern Boulevard, L. I. C. 1, N. Y.  
Over 1 Million EICO instruments in use the world over.

©1958

# EDITOR'S REVIEW

---

## THE PAST MONTH

**J**ANUARY HAS BEEN an interesting month in the high-fidelity industry, what with the scramble for stereo cartridges, meetings of the Electronic Industry Association, and the demonstration of a new system of stereo recording. Just such a month as we enjoy because of new developments—one in which we have to keep awake continually.

Electro-Voice announced and demonstrated a new stereo cartridge composed of ceramic elements and to be available at a price of \$19.50 with a diamond stylus; one other model of cartridge was announced in the trade press at a probable price of around \$80; and there have been other cartridges and rumors of cartridges which are not yet to the official announcement stage. Naturally every manufacturer will have his own version of a stereo cartridge before long.

The new system of stereo recording being shown employs a standard—but necessarily high-quality—monaural cartridge which plays a groove on which one channel derives from a frequency-modulated carrier which is recorded along with the conventional lateral recording. While this system would not require a stereo cartridge, it does need a converter unit to unscramble the FM signal, with the converter said to range around \$30 in cost.

The Electronic Industry Association held several meetings aimed toward standardization of stereo disc recording standardization as to stylus tip radius, recording levels, and standard positioning of right and left channels. There is still much to do before we may expect stereo discs in quantity, but we can still expect them.

Our own efforts in making a conversion of the popular General Electric VR-II cartridge took up rather more time than we expected after the first model was built. Having constructed one in some five days' time after the conception of the original idea, we spent several more weeks in finding out how to do it in a manner which was simple enough to be able to impart it to our readers. Undoubtedly there will be stereo cartridges on the market just about as soon as the records will be available, but we just couldn't resist the temptation to continue our own "do-it-yourself" habit to this extent.

One would be surprised at how much he can learn about phonograph cartridges by trying to build one—we're only glad we didn't have to start from scratch.

## TAPE VS. DISC

There has been a lot of talk about how the stereo disc would destroy the market for stereo tapes. We look upon this as complete nonsense.

One can make a good case for the LP monaural disc

over the ordinary monaural tape—the former is cheaper, quality is excellent, it is easier to handle—placing on the machine and operating—and it takes up less storage space per minute of playing time. But in spite of these advantages, there are many thousands of people who *will* go to the extra trouble of handling, who *will* pay more for tape, and who *will* provide the extra storage space (not to mention the extra cost of a good tape player over a record player, changer, or even professional turntable and arm). We don't think there is any question but that tape quality is better—*when played on a good tape machine*—and that alone is still enough to attract those who are not satisfied with anything less than the best. And since it has already been shown by sales figures that there are many who want the best, we may reasonably assume that there will still be plenty who will continue to buy stereo tapes just as they have buying monaural (and stereo) tapes to date. We do not see a large swing *to* tape, nor do we see a large swing *away from* tape—tape is admittedly better in quality than discs under optimum conditions, and there are still many people who will never be satisfied with anything but the best.

## THE LOS ANGELES SHOW

While there has not been much national publicity about the forthcoming Los Angeles High Fidelity Show, we understand that there has been considerable in the western hi-fi hotbed. The fact that the New York show is in our own backyard, so to speak, has probably led us to believe that a hi-fi show anywhere is an event of real importance to everyone. Those who are connected with the industry in any way are naturally most interested in its goings on. The fact that there is to be a show in Los Angeles from February 26 to March 2 is only of academic interest to a resident of Manchester, N.H. or Slaughter Beach, Delaware. The market from which any show draws its attendance is more likely to be encompassed in a circle with a radius of less than a hundred miles from the site of the show.

Be that as it may, there *is* to be a show in Los Angeles, at the Biltmore Hotel, beginning on February 26 and lasting through March 2. There is to be one in San Francisco, in the Whitecomb Hotel, February 14-16. And there is to be one in Denver—Cosmopolitan Hotel—February 7-9. Audio will be represented at all of them, and we trust we will enjoy them thoroughly.

Sometimes we wonder if there could be something wrong with a person who goes to six or eight of these shows every year *and enjoys every one of them*. We have found that to be the only way to see everything that's new, and we *do* enjoy them.

# Come on—CELEBRATE!

## PICKERING'S 12th Anniversary Special



THIS YEAR — 1958 — PICKERING & CO. marks its twelfth year as leader in the field of high quality transducers and precise electronic devices for the most exacting engineering applications.

THIS YEAR — 1958 — PICKERING & CO. announces its readiness for the new stereo-disk. Yes, it is twelve years since PICKERING & CO. was first with a high quality miniature magnetic pickup for high fidelity reproduction from records and broadcast transcriptions. And now, PICKERING & CO. is ready for the stereo-disk with the STANTON 45/45, a stereo model of the renowned FLUXVALVE cartridge.

THIS YEAR — 1958 — PICKERING & CO., in its twelfth year of progress, will celebrate their anniversary by giving each purchaser of a FLUXVALVE product a bonus gift valued at (\$6) six dollars to extend the utility of the product they have purchased.

THIS YEAR — 1958 — marks another first for PICKERING & CO. with the PICKERING \$6 BONUS BILL! Beginning February 1, 1958 and until April 15, 1958—each PICKERING FLUXVALVE product will be packaged with a bonus bill valued at \$6. Redeem it on the spot at your PICKERING dealer.

NOW! When you buy a PICKERING FLUXVALVE Model 350, 370, or 194-D, you receive a gift of a bonus bill for which you can receive—

1. Any PICKERING "T-GUARD" sapphire stylus... value \$6... absolutely FREE!
2. A credit of \$6 toward the purchase of any PICKERING "T-GUARD" diamond stylus you choose.

NOW! You can get the \$24 amazing PICKERING ½ mil diamond stylus for only \$18!... or, any of the other \$18 diamond "T-GUARD" styli for only \$12!

**BUILD UP THE QUALITY OF YOUR HI-FI SYSTEM WITH A PICKERING FLUXVALVE**



**FLUXVALVE TWIN SERIES 350**—A turnover cartridge providing a rapid change of stylus point radius. Available in 12 models featuring many combinations of styli. prices start at a modest \$24.



**FLUXVALVE SINGLE SERIES 370**—A miniature high quality cartridge for use in any type of auto-changer or manual player arm. Available in 5 models, prices start at a low \$17.85.

**Model 194D UNIPOSE Pickup Arm**—This new... lightweight... integrated arm and cartridge assembly containing the FLUXVALVE with exclusive "T-Guard" stylus—is only a fraction of the weight of conventional tone arms. High compliance and single friction-free pivot bearing assure distortionless tracking of



microgroove and standard groove recordings. Available with the ½, 1 or 2.7 mil diamond stylus. Prices from \$59.85.



*"For those who can hear the difference"* FINE QUALITY HIGH FIDELITY PRODUCTS BY  
**PICKERING & COMPANY, INC., Plainview, N. Y.**

Enjoy a demonstration at your hi-fi sound studio... you'll hear the difference. For the dealer nearest you or for literature write Dept. A28

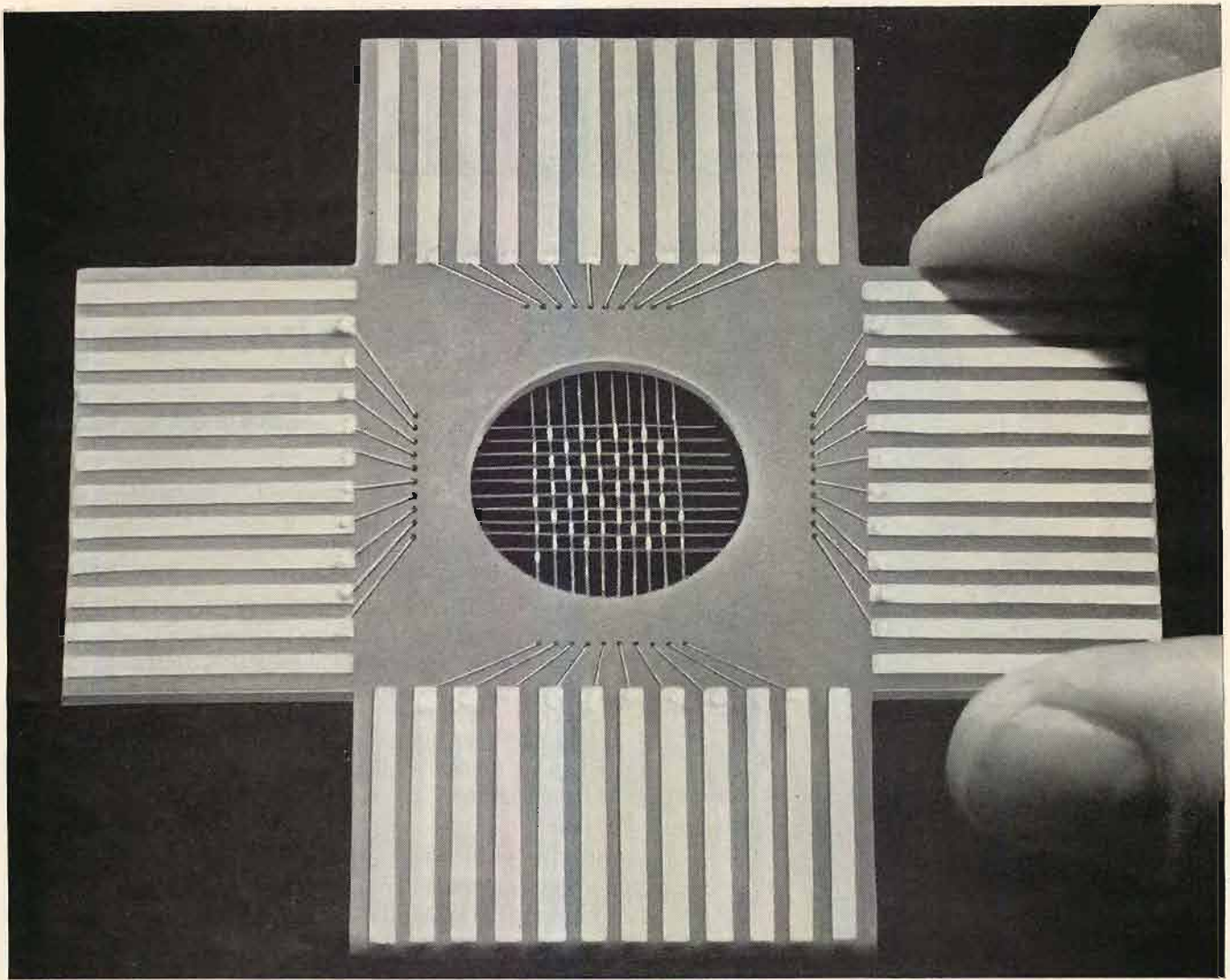

Model (simplified) illustrates basic structure of magnetic "Twistor" memory—magnetic and copper wires interwoven as in a window screen. Twisted condition of the magnetic wire shifts preferred direction of magnetization from a longitudinal to a helical path. One inch of twisted wire, thinner than a hair, can store as much information as ten ferrite rings. "Twistor" was invented at Bell Laboratories by Andrew Bobeck, M.S. in E.E. from Purdue University.

## New twist in memory devices

An ingenious new kind of magnetic memory has been developed by Bell Laboratories scientists for the storage of digital information. Known as the "Twistor," it consists basically of copper wires interwoven with magnetic wires to form a grid.

"Twistor" gets its name from a characteristic of wire made of magnetic material. Torsion applied to such a wire shifts the preferred direction of magnetization from a longitudinal to a helical path. This helical magnetization has been applied to produce a magnetic storage device of unprecedented capacity for its size.

In a magnetic memory, information is stored by

magnetizing a storage element. In conventional memories the storage elements consist of rings of ferrite. In the "Twistor," they consist of tiny segments of hair-thin magnetic wire. At each intersection of the grid, one such segment is capable of storing a binary digit.

The "Twistor" is simple and economical to fabricate, and its minute energy requirements are easily supplied by transistor circuits. Bell Laboratories engineers see important uses for it in future telephone systems which demand the compact storage of much information, as well as in digital computers for civilian and military applications.

**BELL TELEPHONE LABORATORIES**

WORLD CENTER OF COMMUNICATIONS RESEARCH AND DEVELOPMENT



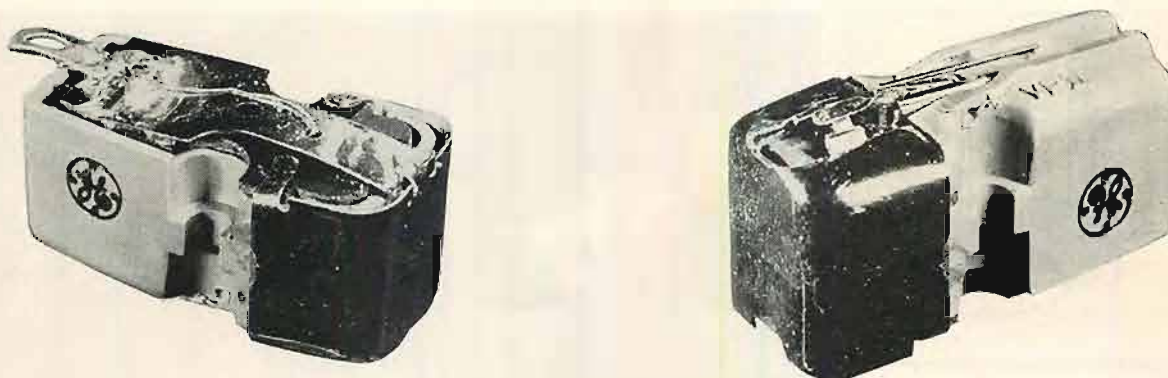

Fig. 1. Top and bottom views of a G.E. VR-II cartridge converted to stereo use.

# How to Make a Stereo Phono Pickup

C. G. McPROUD

With the high current interest in stereophonic discs, the curious experimenter wants to be able to play any that he may get his hands on. A fairly simple conversion of the G.E. VR-II cartridge makes it possible, and gives excellent stereo results.

**W**HEN WE FIRST RECEIVED OUR review copy of Audio Fidelity's initial stereo disc, we were naturally anxious for some means for playing it. The unit employed in the Westrex demonstrations had been, we were told, hand built from two ESL cartridges, and we felt that if Westrex engineers could make such a modification we could, too. After hours of thinking on the subject, we made our first attempt using a GE RPX-050 cartridge. Results were satisfactory as to stereo effect, but quality was not quite so good. Furthermore, it appeared that the modification of a VR-II would be much simpler, so we made several more conversions just to get into the swing of it—and to gather the information necessary to pass the method on to others. In the course of the project, we undoubtedly became one of GE's best customers, for we exhausted the supply of both cartridges and styli in our own particular segment of Long Island. We have, however, converted five VR-II cartridges, and the results are

quite uniform. *Figure 1* shows a completed stereo cartridge.

## Theory

To understand the requirements of a stereo cartridge, let us first consider the mechanics of the Westrex stereo disc system. *Figure 2* shows the action of the walls of the record groove. In (A), modulation is applied only to the left wall—this modulation being "hill and dale" with respect to the flat side of the wall, which makes it at an angle of 45 deg. with the vertical. As the groove wall is modulated, it takes the positions shown by the dotted lines, and the stylus moves on a line at an azimuth of 45 deg. If only the right wall were modulated, the stylus would move at an azimuth of 315 deg., or -45 deg.

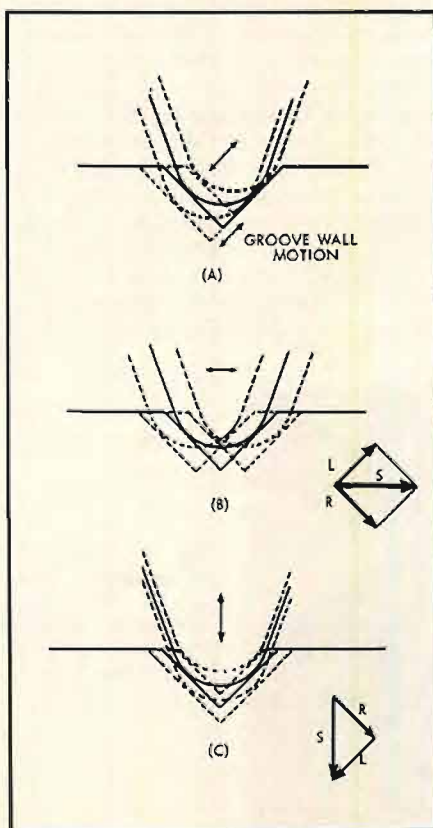

Fig. 2 (right). Geometry of Westrex stereo system. (A) shows stylus motion for modulation of only one groove wall; (B) shows motion for out-of-phase modulation; (C) shows motion for in-phase modulation. Identical signals fed to both channels should produce motion of (B).

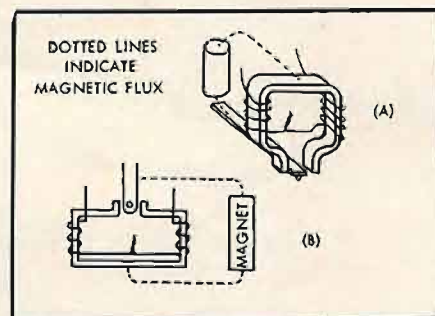

Fig. 3. Schematic arrangement of normal monaural GE VR-II cartridge.

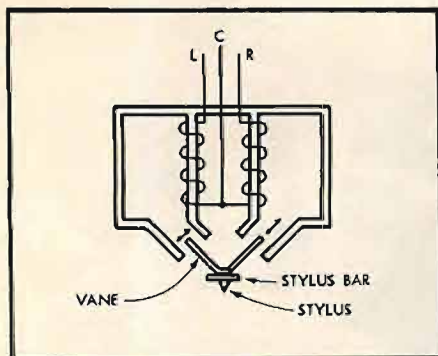

Fig. 4. Schematic of modification necessary to provide two-channel stereo operation.

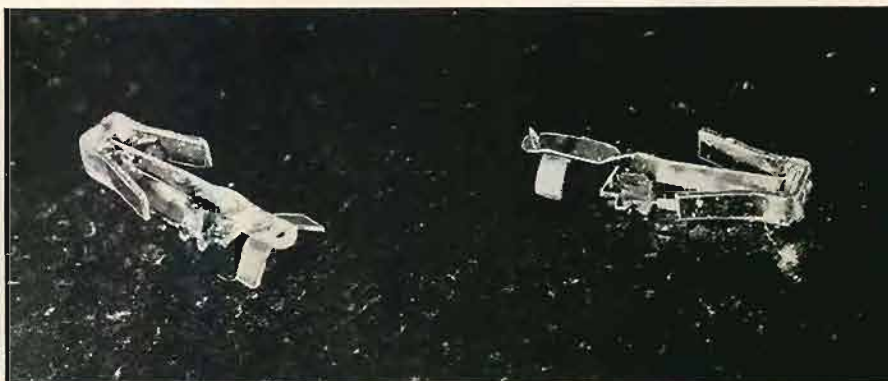

Fig. 5. Vanes are spot welded onto stylus bar in position shown here. Note that stylus is lost from assembly at the left.

When both walls are modulated at the same time, either a lateral motion or a vertical motion is imparted to the stylus. If the modulation is out of phase on the two groove walls, the stylus moves to the right and left, as in (B); if the modulation is in phase, the stylus moves up and down, as in (C). Since the two signals in a stereo system are not always exactly in phase, the stylus motion consists of various combinations of these movements. However, a pure right-and-left motion of the stylus tip gives two resultants, as shown in the small vector diagram in (B); similarly, a pure up-and-down motion also gives two resultants, as at (C), but here it will be noted that the vector, *L*, for the left channel is reversed in direction from that of the vector in (B), and that the direction of the *R* vector remains the same. For our purposes, then, it is necessary that we have some element which senses motion in the two planes—+45 deg. and -45 deg.

The normal GE pickup consists of a sensing element for lateral motion only. Figure 3 shows the schematic arrangement. At (A) the magnetic flux flows from the top of the magnet to the top of the core, and from the bottom through the stylus bar; (B) shows the "schematic" of the magnetic circuit. As the stylus moves laterally to the right, for example, an increased flux flows through

the right leg of the core and induces a signal of one polarity in the coil, while decreased flux in the left leg of the core induces a signal in the left coil. Proper polarization of the coils gives an additive signal. Any vertical motion of the stylus does not appreciably change the magnetic circuit, and no signal is induced in the coils.

Using the same principle, but simply providing two sets of pole pieces and some arrangement to simulate the stylus bar, we arrive at the arrangement of Fig. 4. The right coil is now in a separate magnetic circuit from the left coil. Motion of the stylus, and the attached vane, in the direction of the arrows will cause the left side of the vane to vary the flux through the left coil, but will have little effect on the right coil; the opposite is true when the stylus movement is at -45 deg.

Such an arrangement gives less output in each section of the coil because there is no longer a "push-pull" effect. Furthermore, with only one coil in each channel, the hum-cancelling effect of the two coils is eliminated. As normally built, the GE cartridge has the two coils in series, but so polarized that they are insensitive to external hum fields. However, in our stereo modification this can not be helped (without adding two extra coils), but we have not found this objectionable on a professional-type turn-

table, albeit it was on a small record player.

From Fig. 4, it should be clear that if we could add a vane to the stylus bar and provide the two magnetic gaps for the vane to move about in, we would have a stereo pickup. The next step was to find out *how* to accomplish this.

#### Stylus-bar Modifications

This is the most ticklish of the operations (and the reason for our need for many styli). The requirement is that a small vane be attached to the stylus bar just back of the stylus itself, the vane having two "wings" at 90 deg. to each other, and each being 45 deg. from the plane of the stylus bar. Figure 5 shows two stylus assemblies with the vanes in place.

The vane itself is cut from a piece of soft iron .006 in. thick. We used a piece of permalloy shielding from an old recording head, but the shell of an RPX cartridge would serve. Shim stock can be used provided the temper is removed by heating to red heat and allowing to cool. Cut a strip 3/64 in. wide by 1/2 in. long and bend it 90 deg. at the center. The bend should not be too sharp, but gently rounding with a radius of, say, .010 in. We first tried cementing this to the stylus bar, but could find no cement that would hold. We then asked a dentist—since they have various types of cements that seem to hold indefinitely—but with no result, except that he suggested a friend who is an orthodontist, and whose work involves spot welding small bits and pieces together. There we got two vanes welded to two stylus bars, and we constructed our first stereo cartridge, using the RPX. But when one of the vanes came off, we decided to do our own spot welding and devised a very simple gadget which actually works.

The TV service boys have a clothespin-like device, for rapid connection of antenna leads to sets on the bench, of the type shown in Fig. 6. The two jaws, made from a Weller soldering gun tip, were soldered to the metal parts of the clip, as were two leads each consisting

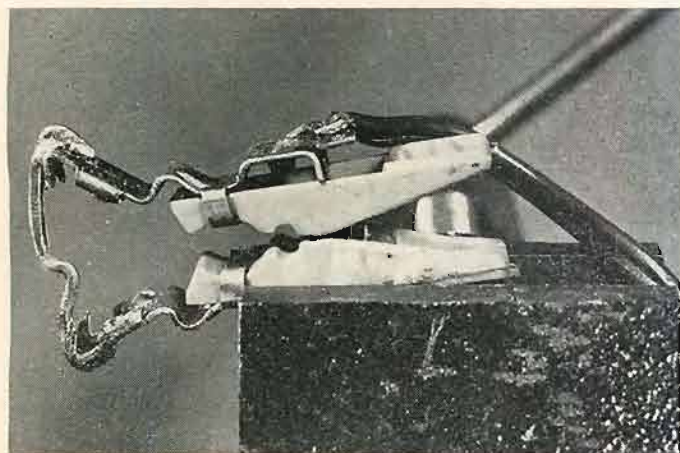

Fig. 6. Modified TV antenna clip serves as spot welder for attaching vane to stylus bar

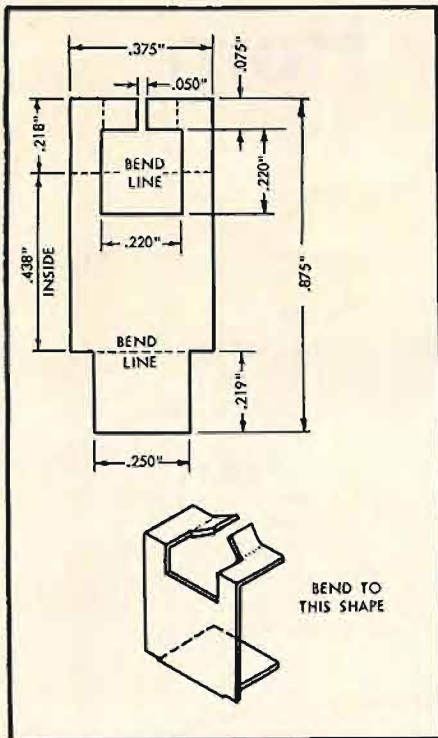

Fig. 7. Details of common pole piece, which is made from .020" transformer lamination.

of the two wires in a short length of zip cord. The bottom jaw is bent so as to get under the tip of the stylus bar, and is filed off at right angles with the point up so as to steady the vane. The top jaw is filed to a blunt point—with a radius of perhaps .010 in.

With the two leads connected to the secondary of a 6.3-volt filament transformer—with a 20-amp. capacity—and with a pushbutton switch in the primary circuit, this arrangement makes a very satisfactory spot welder. Remove and save the damping rubber from under the stylus tip and cut off the carrier just ahead of the finger-grip projections. Place the vane over the bottom jaw, and put the stylus bar over it as close to the stylus as possible. Let the clip close to hold the parts together and press the pushbutton for about half a second. That's all it takes—too much time will burn off the tip of the stylus bar, too little and the vane won't stick. A little practice is recommended before attempting this with the stylus itself; after the first few welds it will seem quite simple.

After the weld is completed successfully, cut off each vane to a length of 5/64 in. and smooth the edges, using a fine file. The ones in the usual set of Swiss pattern files are very useful for this entire operation. Adjust the vanes to an exact 90-deg. angle, with both sides having a 45-deg. angle with the stylus bar.

When this operation is mastered, you are practically ready to go into production.

### Disassembly of the Cartridge

To get at the insides of the cartridge requires disassembly. Pry up the tips on the front shield and remove it, and remove the top electrostatic shield and the insulating strip under it. Carefully scrape away as much of the wax as possible and save it for later use in reassembly.

With a small screwdriver, lift out the top pole-piece section, and follow with the smaller piece. These two U-shaped parts straddle the pole pieces in the coils and hold them firmly. From the bottom, press on the pole piece tips alternately; they will push out the two coils as they are pushed upward. Dress the coil assembly back over the cartridge case. The leads are fairly stiff, and need not be disconnected. Remove the magnet from its compartment. Lay the case aside for later work.

### Preparation of Pole Pieces

The common pole piece is made from a lamination from an old transformer, with a thickness of .020 in. being recommended. Cut the piece to the size and shape shown in Fig. 7. The square opening should be made by drilling a 3/16-in. hole first, then filing to the required dimension. The slot at the top is readily done using the flat file from the pattern set. The lower sketch in Fig. 7 shows how the common pole piece is bent, with angles of 90 deg. at top and bottom, and the two tips bent upward at 45 deg.

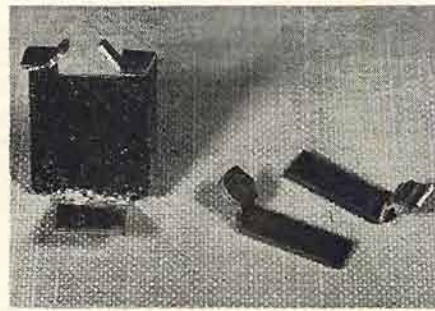

Fig. 9. Common pole piece, at the left, with the two modified pole pieces which go through the coils.

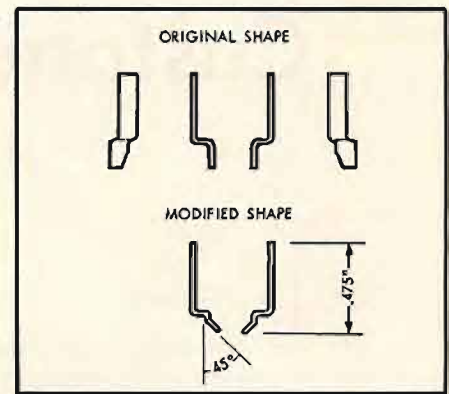

Fig. 8. Original pole pieces must be modified in this manner.

The two pole pieces from inside the coils have shapes like those at the top in Fig. 8 originally. These should be modified to the shape shown at the bottom. Note that the tips are cut off slightly. The 45-deg. bend is easily made by holding the tips in a vise, spacing the upper part by a screwdriver blade. Tapping the handle of the screwdriver will make a sharp bend without deforming the rest of the pole piece.

Figure 9 shows the pole pieces as completed. Scale on common piece shows in the photo, but should be removed as much as possible with fine steel wool.

### Preparation of Cartridge Case

In order to clear the new parts, the cartridge case must be modified, as shown in Fig. 10. The filing on the bottom of the case brings the flat surface just to the bottom of the channel for the stylus carrier. The ridges at the sides of the stylus carrier are sloped off also.

The lead between the two coils should now be freed of wax, and the common wire attached. A single strand from a length of lamp cord is about the right size. It should be twisted around the joined leads from the coils, soldered, and dressed around the side of a coil. Insert the two pole pieces into the slots

(Continued on page 40)

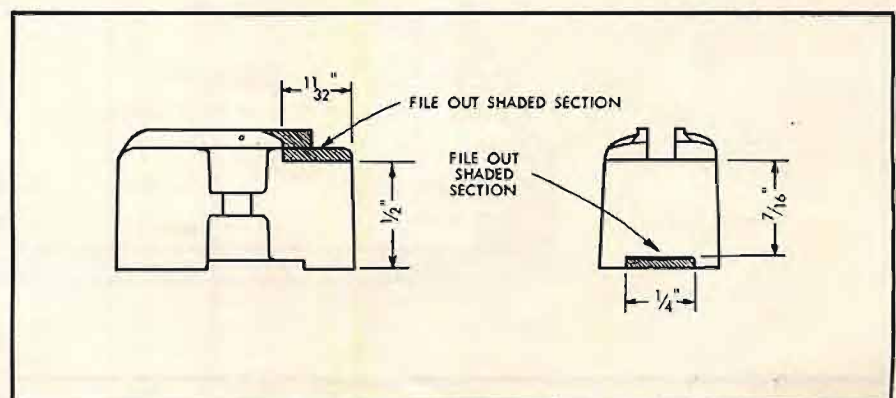

Fig. 10. Cartridge case modification is done by filing as shown.

# Custom-Built Corner Horn Enclosures

LAURENT GAGNON\*

The author describes two low-frequency back-loaded corner horns—one with a theoretical cutoff of 40 cps and the other with a cutoff of 32 cps.

THE FIRST OF THE TWO enclosures to be described will be a specially designated corner version of the Laboratory Standard Reference Loudspeaker, utilizing the new Jensen KT-31 kit, the Imperial 3-way system. It was designed to satisfy those who prefer to have a corner version of this magnificent speaker system and who are able to build their own enclosure or to have it constructed to their specifications by a competent carpenter.

This new model looks smaller than the PR-100, being only 45½ in. high. It produces a single-sound-source effect at a closer range, the woofer being mounted nearer the mid-frequency and high-frequency

units than it is in the PR-100. For those who want to know more about this kind of horn enclosure or to understand thoroughly its theory, design, construction, installation and operation, I suggest that they read carefully the three excellent articles written on this subject by competent Jensen engineers.<sup>1, 2, 3</sup>

The horn parameters are indicated in Table I and they are practically the same as the PR-100.

<sup>1</sup> Daniel J. Plach, "Design factors in horn-type speakers." *JAES*, October, 1953.

<sup>2</sup> Daniel J. Plach and Philip B. Williams, "A laboratory reference standard loudspeaker system." *AUDIO*, October, 1954.

<sup>3</sup> Karl Kramer, "Building the Jensen Imperial." *Audiocraft*, November, 1955.

TABLE I

|                              |             |
|------------------------------|-------------|
| Cut-off frequency            | 40 cps      |
| Taper rate, Hypex flare      | T. 7        |
| Throat or take-off           | 80 sq. in.  |
| Mouth area                   | 704 sq. in. |
| Path length                  | 68 in.      |
| Sound-chamber volume         | 5000 cu in. |
| Acoustic crossover frequency | 175 cps     |

## Construction

Constructional data are given in *Figs. 1 and 2*. Use ¾" hard plywood, glued and screwed together. The inside surface of the horn must be sanded and given three coats of shellac. Cleats or glue blocks 1" by 1" are used throughout in corners between panels and top, bottom, and inside separations.

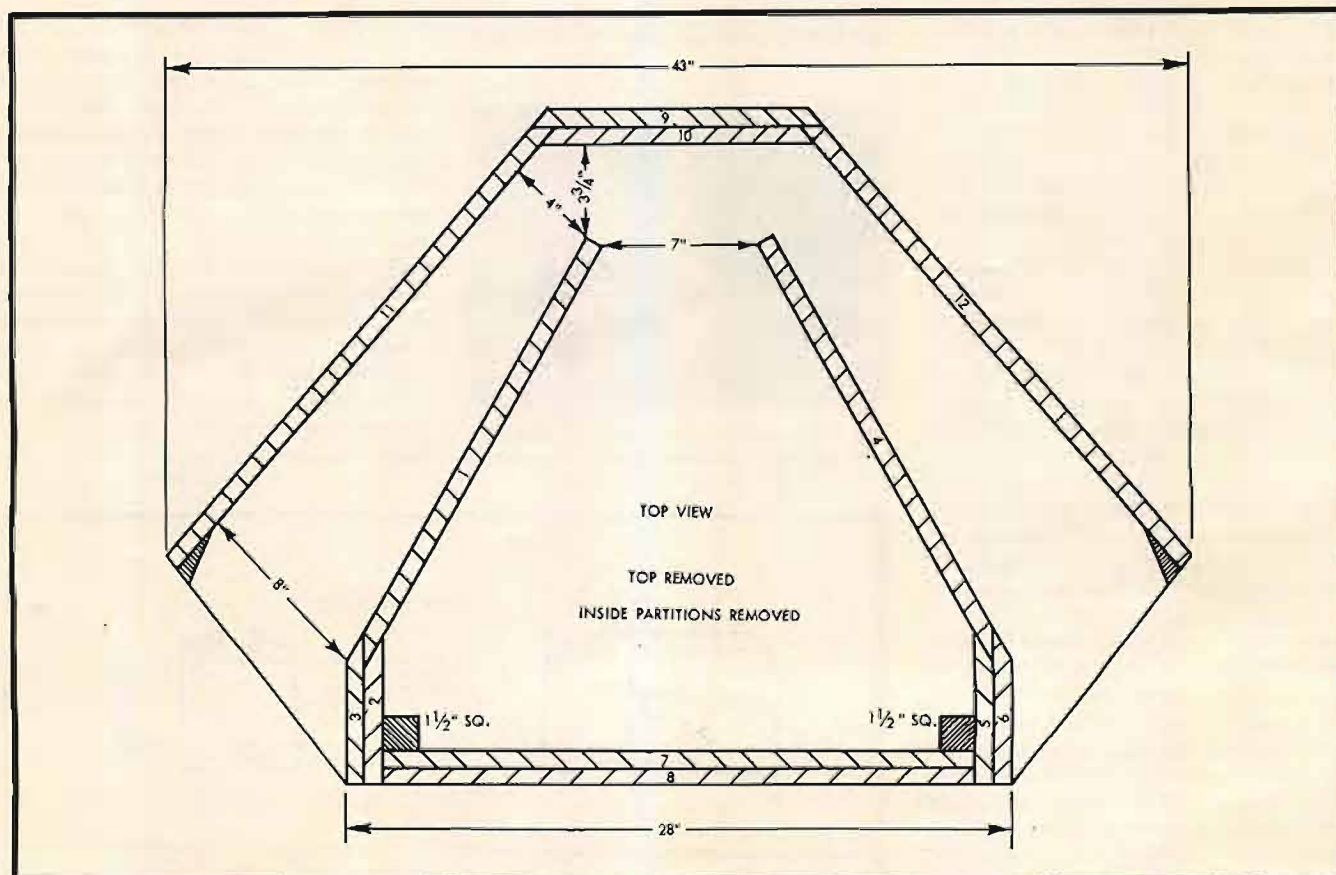

Fig. 1. Plan view of first type of horn. This is a corner version of the Jensen "Imperial" reproducer, in effect, and appears to be somewhat smaller because of the corner use.

Fix six dowels between panels 1 and 11 and six more between panels 4 and 12 to strengthen. Place three horizontal stiffening members  $\frac{3}{4}'' \times 3''$  on rear of back side panels 11 and 12 at 11'', 22'' and 33'' high. The woofer is mounted on the front panel, which is removable, while the mid- and high-frequency units are fired in the open front. The intra-range equalizer and the two crossover networks are placed on the sides of the M.F. and H.F. units in the same compartment. For appearance sake, a base  $1\frac{1}{2}$  to 2 in. high can be added to the cabinet if desired. The entire horn should be isolated from the floor by means of  $\frac{1}{4}''$  to  $\frac{1}{2}''$  thick Ozite or rubber.

If you have a perfect corner and if you wish to simplify the enclosure, panels 11 and 12 may be eliminated but on only one condition: the horn should be permanently fastened to the two walls to avoid air leaks of any kind which would have adverse pressure effects on performance near the cutoff region. Fig. 3 shows such a horn with panels 11 and 12 removed.

For more particulars on the construction, assembly and final adjustment of this model, see full explanations given for the second model for which construction is similar.

With this 3-way system, voices come to life and I can repeat what Jensen claims—that there is a new and almost geometrical separation of instruments.

#### Lower-Frequency Model

The second horn to be described was designed for the audio expert who wishes to go still lower in the low-frequency range with an enclosure of reasonable dimensions. We know that even some of the largest and most expensive corner horns exhibit serious weaknesses below 35 cps. They cut off very sharply so that while their response may be excellent down to 35 or 40 cps, they produce very little fundamental energy below 30 cps.

This new horn has a lower cutoff of 32 cps in order to obtain maximum efficiency at 30 cps, good efficiency down to 26 cps, and enough remaining efficiency as low as 22 cps. Because of reactance-annulling principle and the extreme rigidity and density of the enclosure, it was possible to extend the operation of the horn, well below its normal cutoff frequency, so a theoretical cutoff of 32 cps was found sufficiently low for the present requirements.

It is essentially a back-loaded low-frequency corner horn in an enclosure scientifically designed around the special high resonance, low resistance, 15-in. Jensen woofer P15-LL, stock No. C-5823, and not a compromise between a short horn and a real horn. It utilizes the more efficient Hypex flare together with

a sound chamber of adequate volume for a 175 cps acoustic crossover frequency. The throat is of the correct size for full efficiency and has an air column of the required length carefully calculated and laid out not to exceed 2-percent deviation of the flare employed. Finally, the mouth is large enough for the cut-off frequency chosen.

The Hypex flare T. 7 was retained because of a higher throat resistance and therefore higher efficiency in the vicinity of the cutoff frequency. To obtain the hyperbolic exponential flare required for this low-frequency Hypex horn (see U.S. patent No. 2,338,262) the following calculations had to be made.

An acoustic horn whose cross-sectional area increases from a value  $S_t$  at the throat of the horn substantially in accordance with the law,

$$S = S_t \left( \cosh \frac{x}{x_0} + T \sinh \frac{x}{x_0} \right)^2$$

where  $S$  = cross-sectional area at distance  $x$  from the throat of the horn measured along the mean acoustic path thereof,

$$x_0 = \frac{C}{2\pi f_0}$$

where  $C$  = the velocity of sound in air, or 13,524 in. per second;  
 $f_0$  = cutoff frequency of the horn, or 32 cps; and  
 $T$  = a constant having a value less than unity, or 0.707.

Solving these equations to obtain the cross-sectional area at every six inches along the acoustic path gives the figures in Table II.

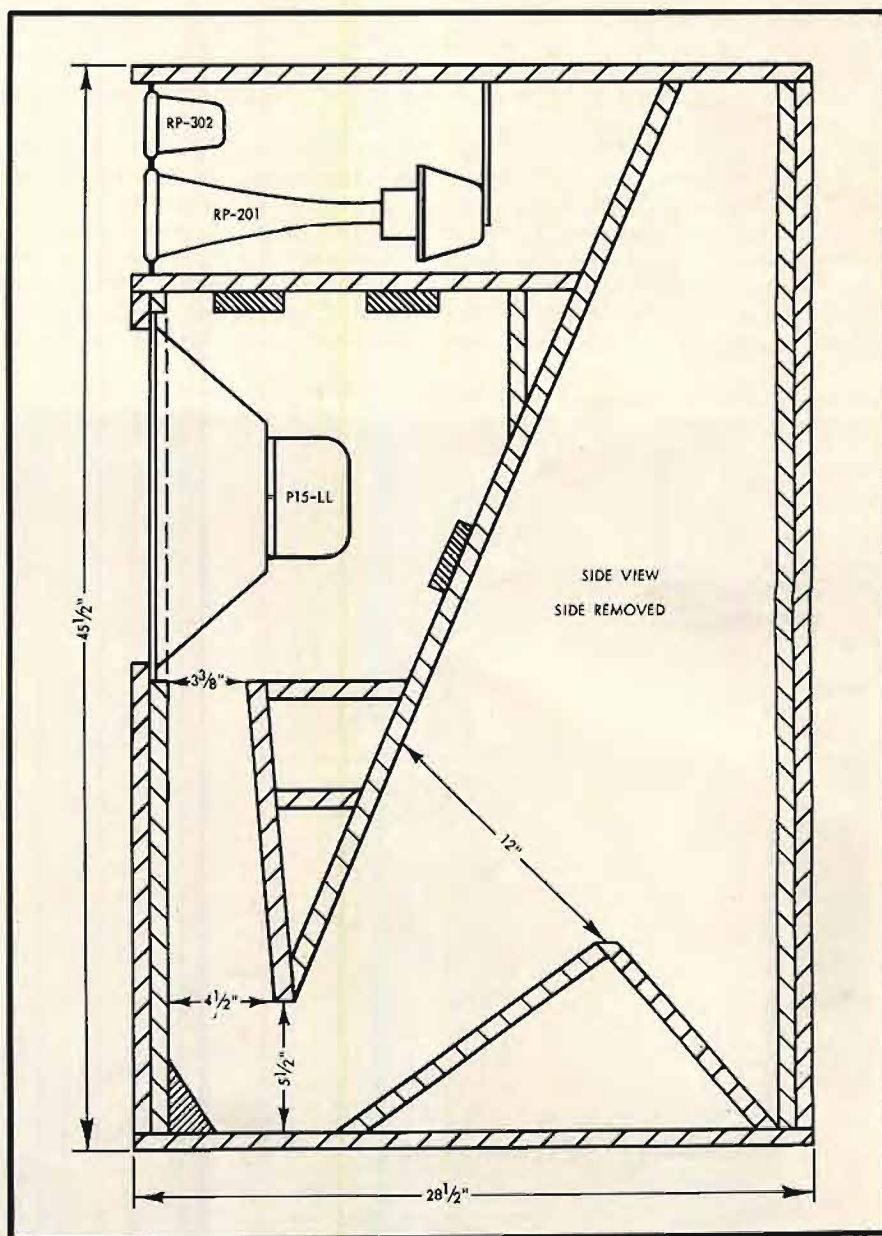

Fig. 2. Cross-section through the center of the first type of horn. The drawings are to scale ( $\frac{1}{8}'' = 1''$ ), and most measurements can be scaled directly from Figs. 1, 2, 4, and 5.

TABLE II

| X   | Cosh  | Sinh  | $\frac{\text{Cosh} + (0.7 \text{ Sinh})^2}{}$ | S, sq. in. |
|-----|-------|-------|---|------------|
| 0   | —     | —     | —   | 80         |
| 6"  | 1.004 | .090  | 1.067   | 91         |
| 12" | 1.014 | .170  | 1.283   | 103        |
| 18" | 1.036 | .268  | 1.498   | 120        |
| 24" | 1.062 | .357  | 1.721   | 138        |
| 30" | 1.100 | .459  | 2.022   | 162        |
| 36" | 1.144 | .555  | 2.347   | 188        |
| 42" | 1.202 | .666  | 2.782   | 222        |
| 48" | 1.263 | .777  | 3.247   | 260        |
| 54" | 1.338 | .888  | 3.838   | 307        |
| 60" | 1.423 | 1.012 | 4.541   | 363        |
| 66" | 1.520 | 1.145 | 5.387   | 431        |
| 72" | 1.629 | 1.286 | 6.395   | 512        |
| 78" | 1.752 | 1.438 | 7.606   | 608        |
| 84" | 1.888 | 1.602 | 9.054   | 724        |
| 90" | 2.040 | 1.779 | 10.791  | 863        |
| 96" | 2.209 | 1.970 | 12.873  | 1030       |

To obtain the required mouth area of our 32-cps Hypex horn, the expression  $D_m \cong 4300/f$  is applicable, however a better equivalent expression on an area basis yields,  $A_m \cong 1.45 \times 10^7/f^2$  which gives a mouth of 14,160 sq. in. for operation in free space. With a corner horn whose walls and floor continue automatically the extension of the horn in the room, the mouth can be reduced by a factor of 8 and when the horn is operated under matched conditions, this area may be further reduced by as much as 50 percent, leaving a mouth area of approximately 885 sq. in. which was now considered feasible for an enclosure; but

this is the irreducible minimum for corner operation only.

For comparison, an exponential horn whose mouth is considered as a circle, must have a diameter which is at least 1/3 of the wavelength of the lowest frequency to be reproduced, or in this case 32 cps. Solving this equation gives a diameter of 150 in. and a mouth area of 17,600 sq. in. in free space, thus requiring a path length of nearly 16 ft. to obtain the same results.

To get maximum efficiency with an enclosure that combines horn backloading and front radiation, a horn having a low cutoff must be designed around a woofer which has a relatively high resonance and should be stiffness controlled below resonance, so the special 15-in. Jensen woofer which has an unloaded resonance (not free-air resonance, but vacuum resonance) of 65 cps and a heavy-bodied cone (moving-system mass is 52 grams) was utilized.

With this woofer, a throat of about 80 sq. in. was considered small enough to get full efficiency. Now if we look at the results of the hyperbolic exponential flare calculations, we find that a path length of 90 in. is necessary to meet the throat and mouth requirements.

Also according to the theory of quarter-wavelength mounting, when the back waves of the speaker travel a quarter wavelength or more before reaching the

waves radiated by the front of the speaker, these front waves will be reinforced instead of cancelled. With this horn, the backwaves will have to travel a distance between 8 and 9 ft. to reach the front waves, so it is quite certain that frequencies near 28 cps and above will be adequately reproduced because no cancellation will take place. This is one of the advantages of a longer air column.

In this horn, the acoustic crossover frequency between front and back waves radiation from the driver should occur between 150 and 200 cps, since higher crossovers may give a rough response due to the tortuous path. In view of the above and considering the woofer employed, a sound chamber of 5000 cu. in. was specially designed in back of the cone so as to obtain an acoustic crossover in the vicinity of 175 cps.

It is thus practically a four-channel system, having from 20 to 175 cps, the radiation from the back loaded horn and from 175 to 600 cps, the front radiation of the woofer. The range from 600 to 4000 cps is reproduced by a compression type, mid-frequency driver and from 4000 cps to upper limit of audibility, by the super tweeter.

These horn parameters must now be concretized from theoretical data to the drawing board and then to an enclosure design that has sufficiently reasonable dimensions to pass through ordinary doors and good enough appearance so that it may be placed without wife's objection in the corner of the living room.

My aim of designing an enclosure not more than 45½ in. high was difficult to realize because of the long path length required. In my first trial, I designed a horn with a mouth of 600 sq. in. and a path length of 78 in. but this model was not considered due to a too small mouth area for the cutoff employed and also because the response below 40 cps will begin to droop considerably and may be jagged due to reflections caused by throat-resistance variations.

Finally after many attempts, the horn path was so ingeniously folded inside the cabinet, that it has already attained a length of 62 in. before turning back at the corner. I have thus succeeded in designing a 32-cps horn that will give optimum performance for the minimum volume of enclosure, but I was obliged to put the M.F. and H.F. units in a small compartment on top of the enclosure.

In a horn, the vibration of the walls distorts the frequency response characteristic and introduces hangover and reverberation with corresponding resonance, coloration, and poor transients. Absorption which is caused by certain materials, including wood, may introduce some attenuation or loss of efficiency and can be reduced by the application of



Fig. 3. The first type of horn in a typical home setting. The appearance is simple, and in a corner location often provides a setting for a vase or some bric-a-brac.

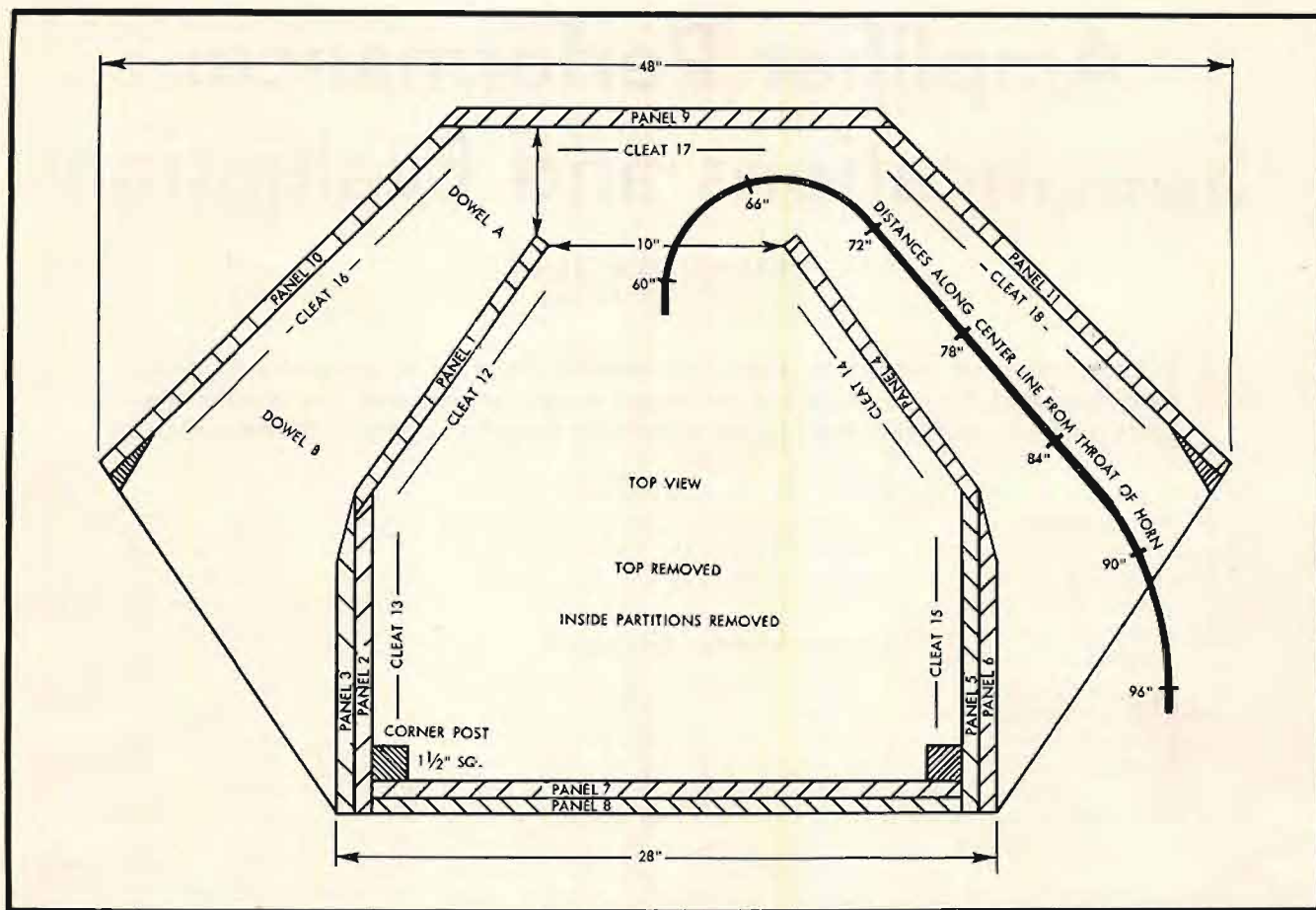

Fig. 4. Plan view of the second type of horn. All of the drawings in this article are to the same scale to permit direct measurement.

shellac or varnish. To avoid these defects the horn walls must be extremely rigid, non-resonant, and non-absorbing, and the inside surface must be hard and smooth with no obstruction.

I have seen also many horn cabinets start to vibrate to the amplitude of some low-frequency notes or to the rolling pedal tones of the great pipe organs and I know by experience that it needs an extra rigid enclosure to eliminate any cabinet vibrations. The construction of this horn was made in accordance with these principles and if you examine *Figs. 4 and 5* you will notice that at the beginning of the horn where the pressure is maximum, the front panel, the two side panels and the two separations have been doubled to obtain a thickness of 1½-in. solid hard plywood for the required density. Also in order to acquire the extra stiffness wanted, we increase the structural strength considerably by adding five 2 × 4 in. braces to support the partitions between the panels inside the enclosure.

At last to avoid absorption, vibration, and resonance in the separator located between the first 48 in. of the folded air column, a density of at least 4 is required for large output at low frequencies. Thus a thickness of 2¼ in. hard plywood was needed and if employed would make the enclosure 31½ in. deep, which is too large to pass through many

ordinary doors. So in order to reduce the cabinet depth to 29½ in. I was obliged to use a material only ¼ in. thick. Because steel has a much higher density than plywood, (7.7 compared to 0.67) it was calculated that a ¼-in. steel plate was the equivalent of 2¼-in. plywood, so a steel plate ¼-in. thick was chosen for this important separator.

Because this new separator does not vibrate any more, it cannot transmit resonances to the other parts of the enclosure which are already heavily braced, thus aiding in lowering the "Q" (resonance) of the plywood and eliminating the last audible resonance and perceptible cabinet vibrations; the enclosure is now practically dead. Because of its higher density, velocity, and specific acoustical resistance, the steel plate gives a brighter sound and in general a better tone of reproduction, because it reduces hangover in comparison with wood.

To convince yourself of the results obtained, I suggest you tap these panels with your fist and your first impression will be that you are not tapping wood but marble. Imagine now what this rigidity, density, lack of resonance, less acoustic absorption, and absence of cabinet vibration could make to the quality of sound reproduced. It also increases the horn efficiency and at the same time

even extends by a few cycles its response in the extreme low end.

The advantage of this back loaded horn is such that it has a large source of sound and fully dispersed which is so necessary for a chorus or big orchestra while at the same time it seems to reduce automatically the size of its sound source to the area of its frontal radiation for perfect intimacy and presence of a solo voice or instrument.

Regarding efficiency, you may say it is not so important today, but before making your judgment, consider the following advantages. The better 3-way horn system gives between 25 and 50 percent efficiency as compared to only 5 to 10 percent for the good bass-reflex systems and as low as 1 to 3 percent for acoustic suspension cabinets, infinite baffles, and so on. A less powerful amplifier can be used or the same amplifier can be operated at a lower setting of the volume control with correspondingly lower distortion and also less chance of overloading. The effect of presence and projection into the room is also better.

A drawback to be considered when using a horn with such a good response at the very low frequencies is that you will be obliged to have a very good hi-fi installation, adequately grounded, and using only the best components—including pickup arm, cartridge and stylus

(Continued on page 75)

# Amplifier Performance: Specifications and Evaluation

HERMAN BURSTEIN\*

When comparing amplifiers from their specifications, it is necessary to make sure that all of the specifications are stated in the same terms. The author suggests points to look for—and points which the manufacturer should make clear.

IN DECIDING WHAT control or power amplifier to buy, the audio fan is guided to an extent by manufacturers' specifications. Among the data of chief interest are signal-to-noise ratio, sensitivity, and IM distortion, all of which depend upon the signal level one is talking about.<sup>1</sup> Unfortunately, when the audiophile attempts to compare specifications of different brands, he finds a startling absence of common denominators. That is, the various brands base their specifications upon different output levels.

For example, the signal-to-noise ratio, sensitivity, and IM distortion of one control amplifier may be based upon 1-volt output, while the performance of another unit may be based upon 5 volts. In the case of power amplifiers, these data are generally based upon rated output, which is the maximum power for a reasonable level of distortion (usually about 1 to 3 per cent IM); but rated output may vary from less than 10 watts to over 100 watts, so that the specifications are quite a way from being comparable.

Specifications for some amplifiers—control and power—are quite complete, while others are sketchy. Therefore, in addition to the problem of comparability of specifications, one often has the second problem of insufficient data for evaluating the suitability of a given unit.

In sum, a need exists for standardization of manufacturers' specifications relating to signal-to-noise ratio, sensitivity, and distortion of amplifiers, and for a more complete presentation of such data. This article seeks to make some suggestions toward solution of these problems. Even in the absence of standardized and complete performance data, it is hoped the following discussion will be helpful to the audio fan seeking to

evaluate the specifications of control and power amplifiers in terms of his own needs and desires.

## Control-Amplifier Specifications

Power amplifiers generally can be driven to rated output by a signal of 0.3 to 2 volts, as indicated by Table 1, showing output and sensitivity for a number of well-known units. The typical sensitivity is not far from 1 volt, which therefore appears to be a suitable standard of reference. It is also a desirable standard because it is a simple, round, easily-remembered figure. Even in the case of the very few power amplifiers with a sensitivity of 2 volts, the outside figure, it is doubtful that the amplifier will more than seldom, if ever, be driven to a level requiring this much input signal; besides, the difference between 1 volt and 2 volts is only 6 db, which is not an excessive margin between used and maximum available power.

Altogether, it seems appropriate and desirable to relate noise (including hum), sensitivity (required signal input), and distortion to an output of 1 volt. (In the case of the IM distortion measurement, one is dealing with equivalent-sine-wave voltage, meaning that the combined waveform of the two frequencies used for this test has a peak amplitude equal to that of a sine wave representing one frequency; since the usual meter reads average rather than peak voltage, the two-frequency reading will be about 0.8 volt.)

In fairness, it is vital that the tests be made with volume control full on; the other controls should be set for flat response. Maximum gain setting logically corresponds to maximum drive from the control amplifier and in turn to maximum output from the power amplifier. If performance is measured, for example, on the basis of a 1-volt output but with gain at mid-setting, then maximum setting would correspond to substantially more than the usually sufficient 1-volt output. This can give rise to misleading impressions about the per-

formance of the control unit, putting distortion and sensitivity in an unfavorable light and signal-to-noise ratio in an undeservedly favorable light, as follows: Requiring the control amplifier to produce a 1-volt output at mid-gain setting may require an input signal large enough to overload the unit and exaggerate the distortion. The sensitivity figure will be increased—made poorer—because of the greater input signal needed to achieve the 1-volt output. On the other hand, the signal-to-noise ratio will be overstated on magnetic phono input inasmuch as the reduced gain setting will attenuate noise of the preamplifier stage(s). Depending upon the particular circuit, there may also be exaggeration of signal-to-noise ratio on high level input; this will happen if high-level signals go through an amplifier stage prior to the gain control.

Given the sensitivity and signal-to-noise ratio specifications based on a 1-volt output, the audio fan can easily translate these, if need be, into performance at lower or higher output levels (with gain full on), because the relationships involved are linear. For example, if the signal-to-noise ratio on high level input is 80 db at 1 volt output, then the ratio is proportionately higher, namely 86 db, at 2 volts output (it is assumed that the control amplifier can produce appreciably more than 1 volt). Or, if the sensitivity is 10 mv on magnetic phono input for 1 volt output, it can be deduced that the sensitivity is 20 mv for 2 volts output.

On the other hand, no such linear relationship exists where distortion is concerned. Therefore the practice of providing a chart showing IM distortion at various output levels is commendable. Usually, however, it is not possible to read such charts with the desired degree of accuracy. Often one cannot differentiate, for example, between a distortion reading of 0.5 or 1.0 per cent. Today it is widely felt that less than 1 per cent IM is desirable in amplifiers, and there appears to be a definite trend toward identifying top notch performance with

\* 280 Twin Lane E., Wantagh, N. Y.

<sup>1</sup>Of course frequency response is also an important factor. But this is essentially independent of signal level—within the rated output of the unit—and therefore is outside the scope of this discussion.

0.1 per cent IM or less. Thus the distinction between 0.5 and 1 per cent or between 0.1 and 0.5 per cent is not important.

For ease and accuracy, it seems desirable to show IM distortion in tabular as well as chart form. Since the average level of music tends to be roughly 20 db lower than the peaks, it seems appropriate to show IM distortion for an output level of 0.1 volt as well as 1 volt; gain control should be kept full on and input signal reduced to the necessary extent. On the other hand, the input level control of a power amplifier (usually there is such a control; if not, there should be) is often turned down in order to reduce control-amplifier noise, particularly if the latter has only a fair signal-to-noise ratio or if the speaker used in the music system is quite efficient. It is difficult to know in advance how much attenuation of this sort is apt to be encountered, but a figure of about 10 db would not be unusual. So it would seem desirable to have the IM distortion for a control amplifier when its output level is 3 volts. Finally, inasmuch as 1 per cent IM is considered about the maximum consistent with high fidelity so far as amplifiers are concerned, it would also be desirable to know how many volts the control amplifier can put out at 1 per cent IM.

#### Evaluation of the Control Amplifier

High-level sources, such as FM tuner, tape machine, TV, and piezoelectric cartridge, ordinarily produce from 1 to 5 volts on peaks. To allow a safety factor, it will be assumed for the purpose of the following discussion that at least 0.5 volt peak signal is available at the high-level input of the control amplifier. It shall similarly be assumed that the magnetic phono cartridge also produces at least 0.5 volt peak signal *after equalization and preamplification*; some of the very-low-output cartridges may not do so, but for such cases the pickup manufacturer usually makes available a step-up transformer to be used between the pickup and the magnetic phono input. For convenience and simplicity, the following discussion will deal with sensitivity largely in terms of high-level sources, but it should be understood that whatever is said about these applies in corresponding fashion to low-level sources.

There is considerable variation in the sensitivity and output voltage figures for various control amplifiers. For example, some may require as much as 0.5 volt input for a 1-volt output, while others may have a sensitivity of less than 0.1 volt for a 1-volt output; some will produce only 1 or 2 volts before they exceed 1 per cent IM, while others can produce as much as 10 to 15 volts at 1

Table 1  
SENSITIVITY AND OUTPUT OF SOME  
POPULAR POWER AMPLIFIERS

| Make                                | Sensitivity | Rated Output |
|-------------------------------------|-------------|--------------|
| Acro Ultralinear II                 | 2 volts     | 60 watts     |
| Altec Lansing 340A                  | 1.3         | 35           |
| Dynakit Mark III                    | 1.5         | 60           |
| EICO HF-60                          | .55         | 60           |
| Fairchild 255                       | .9          | 30           |
| Fisher 20-A; 55-A; 80-AZ            | 1           | 15; 55; 30   |
| Electro-Voice A15; A30; A100        | 1.25        | 15; 30; 100  |
| Gray AM-50                          | 1.5         | 50           |
| Grommes 221; 260                    | 1           | 20; 60       |
| Harmon-Kardon Melody II; Trend II   | .3          | 20; 40       |
| Heath W-3AM; W-6M                   | 1; 1.1      | 22; 70       |
| Interelectronics Coronation 400     | 1           | 40           |
| Lafayette LA-70                     | 2           | 70           |
| Letronics Custom 56                 | 1.5         | 50           |
| Marantz                             | .7          | 40           |
| McIntosh MC-60                      | .5          | 60           |
| Printed Electronic Research Peri-50 | .75         | 50           |
| Quad II                             | 1.4         | 15           |
| RCA SP-10; SP-20                    | .45         | 10; 20       |
| Regency HF-50K                      | 1.5         | 50           |
| Rogers (Ercona) Cambridge; Eton     | .6; 1       | 10; 25       |
| Sargent-Raymont 240; 280            | .5          | 40; 80       |
| Stromberg-Carlson AP-428            | 1.95        | 25           |
| Tannoy 40-watt                      | .4          | 40           |
| Techmaster TM-15A                   | 1.1         | 20           |

per cent IM. To the extent that maximum output at reasonably low distortion, say 1 per cent, exceeds 1 volt, this may be regarded as a plus factor for the control amplifier being evaluated, because it permits the input level control of the power amplifier to be turned down, thereby attenuating noise produced by the control unit and improving the signal-to-noise ratio for the total system. For example, assume that the signal-to-noise ratio on high-level input is 70 db below an output signal of 1 volt, and that the control amplifier can turn out 10 volts at 1 per cent IM. If the power amplifier has a sensitivity of 1 volt and its input level control is set to reduce an input signal of 10 volts to 1 volt, this results in a 20 db reduction in control amplifier noise at the same time, so that the signal to noise ratio of the latter is in effect raised by 20 db to 90 db.

Whether the control unit can be driven to 10 volts so as to take advantage of the potential improvement in signal-to-noise ratio depends not only upon its IM curve but also upon its sensitivity. In other words, how much input signal is necessary to drive the unit to 10 volts? If the sensitivity based on a 1-volt output is rated, say, at 0.1 volt, this translates into 1 volt input for 10 volts output. Inasmuch as 0.5 volt input is all that one can be sure of, the full 20 db increase in signal-to-noise ratio may not be feasible. However, one can be quite certain of obtaining 0.5 volt input and therefore 5 volts output. Using the input level control of the power amplifier to attenuate 5 volts to 1 volt is a cut of 14 db—a noise reduction not to be sneezed at.

On the other hand, while the most input signal one can be sure of is 0.5

volt, the *probability* is quite high of being able to obtain 1 volt, so that the full 20 db improvement in signal to noise ratio of the control amplifier may be within reach after all.

#### Power Amplifier Specifications

When speaker systems of average efficiency are used in rooms of typical size and furnishings, the maximum power output apt to be required for normal reproduction is under 10 watts, often as little as 1 watt or even less. True, there are some speakers of extremely low efficiency (albeit high quality) that may require as much as 20 watts or more, but on the other hand there are also speaker systems of very high efficiency that may draw only a fraction of a watt. On the whole, an output of 1 watt seems to be a reasonable standard of reference for comparing power amplifiers intended for home use, and has the advantage of being a convenient, easily remembered number. While 10 watts might seem an equally appropriate reference level, it is too high because there are a few power amplifiers which are rated at less than 10 watts, yet perform well enough to come within the high fidelity category.

Thus, in specifying signal to noise ratio, sensitivity, and IM distortion, a suitable reference level appears to be an output of 1 watt, although conventionally these ratings are based upon rated output, which may range from less than 10 to over 100 watts.

In the case of signal-to-noise ratio, a figure based on rated output tends to exaggerate the amplifier's performance. For example, consider a 100-watt amplifier with a signal-to-noise ratio of 90 db

(Continued on page 53)

# Simple Electronic Switch for Magnetic Sound System

DR. ING. PIERANTONIO CREMASCHI\*

While most electronic switches for audio circuits are relatively complex in order to avoid the possibilities of "thumps," this one gives the desired results with a minimum of components. Many applications will undoubtedly come to mind.

In this article a new circuit for a simple and inexpensive electronic switch is illustrated. The pilot signal used has a frequency of 12,000 cps, but with slight changes in the filter networks, any available frequency outside the audio band employed could be used.

Schematic diagrams are given with the values of all components and instructions for alignment. There should be no difficulty in assembling this circuit which was developed for those theatre sound systems whose over-all cost must be kept as low as possible. It switches on and off the loudspeakers installed at the back of the audience whenever the pilot signal is recorded on the fourth magnetic track of the film. Vari-

ous elements of the circuit may possibly find other applications, also.

Notwithstanding its low cost this circuit has the advantage, over conventional circuits, that it works also when the speed of the film deviates from its nominal value even  $\pm 30$  per cent, owing to possible variations of mains voltage or frequency. In the conventional circuits the pilot signal is amplified in tuned amplifiers and of course this requires the constancy of the frequency of the pilot signal.

In home moving picture sound systems, particularly in stereophonic sound reproduction, this electronic switch could usefully be used to create interesting back-effects. Back loudspeakers should be installed to be driven by the switch. The electronic switch illustrated is, of course, clickless and has a good

transient response. Therefore the audio experimenter should find it rather useful in his work, when periods of "on" and "off" must be provided in an audio amplifier.

In the case that absolutely clickless operation is required, it is necessary that the direct current be eliminated from the load resistance of the amplifier to be cut off. As is well known, this can be accomplished by a push-pull arrangement of two tubes.

Details are also given in this article for building a preamplifier, with electronic tubes and of rather conventional design, necessary to amplify the signal coming from the magnetic head. Suggestions are given for building a simple transistorised preamplifier which of course, has many advantages over the

\* *ELIT, Elettronica Italiana, 14 Salvioni St., Milan, Italy.*

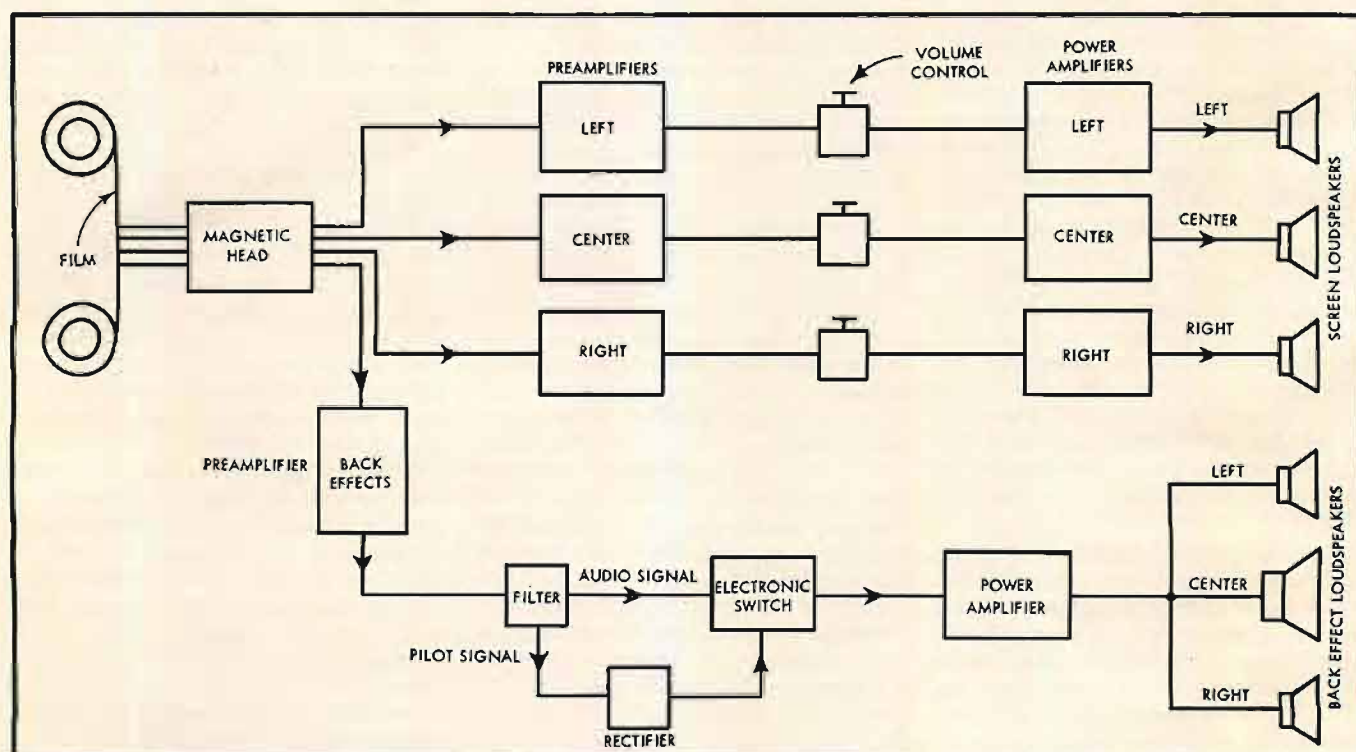

Fig. 1. Block diagram of a Cinemascope magnetic sound system.

monte carlo



decorator



barrington

fiesta



# LIVE SOUND

is the closest thing  
to a Weathers speaker

Listening is your dynamic proof! With any Weathers Speaker System you'll hear the full range of sound audible to the human ear... sound re-created at any volume, any frequency, to "natural perfection". Audiophile or beginner, a Weathers Speaker is your *finest source to professional* sound within your own home. This achievement is made possible by Weathers exclusive sonic principles: "radial damping" backwave control, exclusive multiple octave crossover, and a new cone-edge treatment resulting in the incredible smooth middle register. Weathers enclosures are constructed of selected, *solid woods*, all surfaces beautifully finished. Listen and compare—the closest comparison is "live" sound.

## Weathers INDUSTRIES

DIV. OF ADVANCE INDUSTRIES, INC.

65 E. GLOUCESTER PIKE, BARRINGTON, NEW JERSEY

Export: Joseph Plasencia, Inc., 401 Broadway, New York, N. Y.

**The BARRINGTON**—a powerful, 12-speaker system, fills an auditorium, yet precisely controlled at 1/10 watt of audio power for small room volume. Offers a fidelity and smoothness of the full range of sound heretofore possible only under controlled laboratory conditions.

**The MONTE CARLO**—a 6-speaker system, graceful and elegant in design... versatile in application. Like all Weathers speakers, Monte Carlo is a finely integrated system offering distortion-free, uninhibited, full range response of every sound audible to human ear.

**The DECORATOR**—modern, slim-lined two-speaker system—ONLY 8 3/4 inches in depth. A luxury speaker at budget price for full-range response with perfect fidelity. Additional Decorator provides three-dimensional sound with unapproachable quality.

**The FIESTA**—a beautiful highly compact two-speaker system. Smallness in size makes no compromise on full-range response with true fidelity at every frequency. Ideal where space is at a premium. Ideal for multiple speaker installations for stereophonic sound.

conventional preamplifier with electronic tubes.

### Cinemascope Magnetic Sound Systems

A Cinemascope magnetic sound system is, as well known, made of four independent sound channels—that is the three screen channels, center, left and right, and the back-effects channel. Therefore four magnetic tracks are recorded on the film. On the fourth track, on which the audio signal of the back-effects is recorded, is also recorded, during the periods of audio signal "on", a 12,000-cps sinusoidal wave. This wave is the pilot signal which must switch on the back-effects loudspeakers. This is necessary because the fourth track is small compared with the others and the signal-to-noise ratio is therefore low. If the back-effects loudspeakers were on during the silent periods, which are usually rather long, an annoying noise would be heard by the audience.

A block diagram of a Cinemascope magnetic sound reproduction system for a motion picture can be seen in Fig. 1. It is made of a four-track magnetic head, which usually has an output voltage of about 100  $\mu$ V when it is connected to a load impedance of about 30 ohms; three identical preamplifiers with equalisation networks for the screen channels; one amplifier, usually with a greater gain, for the back-effects loudspeakers and without equalisation networks; a separate volume control and bass and treble tone controls; a filter network necessary to separate the audio signal from the pilot signal; a rectifier circuit; an electronic switch; four power amplifiers; and, of course, the various loudspeakers.

It is not the purpose of this article to illustrate the above mentioned components, but, in the following, details

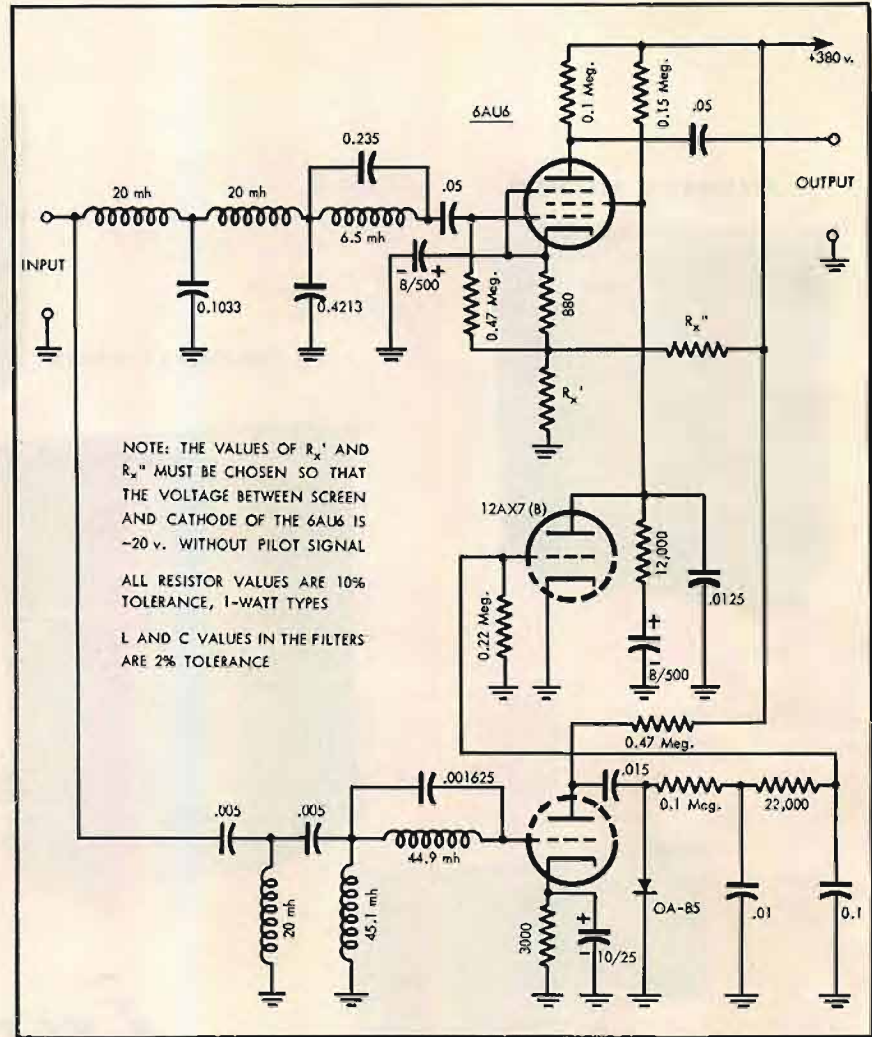

Fig. 3. Schematic diagram of electronic switch with filters and rectifier.

will be given of the electronic switch with its associated elements.

### Electronic Switch, Filter and Rectifier

Figure 2 shows the working of the

switch, filter, and rectifier. The audio signal amplified in the preamplifier together with the 12,000-cps signal is fed through a filter network which separates the audio signal from the pilot signal. The recorded band-width of this audio signal is rather small, from 50 cps to 6000 cps, and therefore a low-pass filter with a boundary frequency of 7000 cps is quite sufficient to separate the audio signal from the 12,000-eps pilot signal. The signal coming from the preamplifier is also fed to a high pass filter with a boundary frequency of 8000 cps which is necessary to prevent the working of the switch owing to the negative voltage obtained by the rectification of the audio signal. The boundary frequency has been kept low owing to the possibility of deviation in the frequency of the pilot signal due to possible slowing down of the film speed, as previously mentioned. The filtered pilot signal is afterwards amplified in an untuned stage and rectified, and the negative voltage which results is applied to the grid of a triode, the auxiliary stage, which is thus brought to cut-off. There-

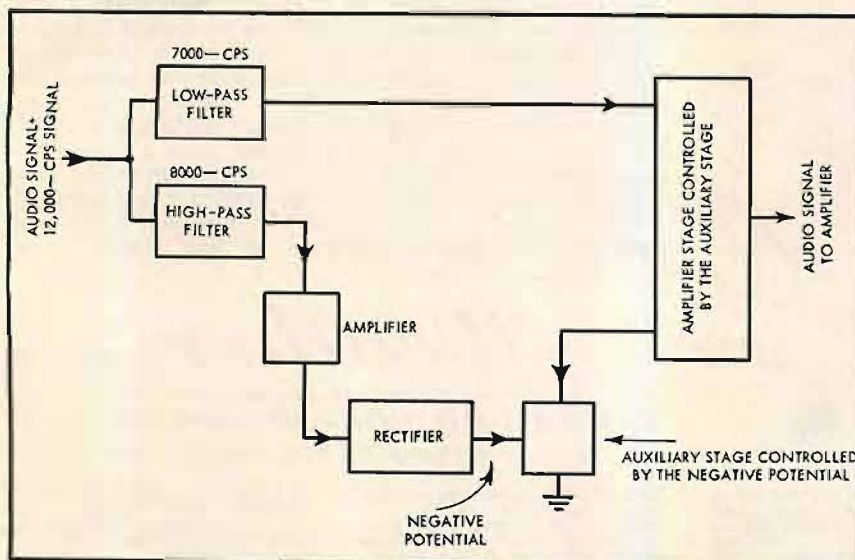

Fig. 2. Detailed block diagram of electronic switch with filters and rectifier.

(Continued on page 72)



**This  
is where  
the music  
begins**

Furniture By JENS RISOM DESIGN INC., N. Y.



*The Collaro* CONTINENTAL, TC-540

**\*New Transcription-Type Tone Arm Makes Collaro  
World's First True High Fidelity Changer**

When you select your high fidelity system—an amplifier with low distortion and low noise level, a speaker capable of reproducing the entire audible range—you want to make certain you pick the right record player. Because that's where **the music begins**. That's why today's fine high fidelity systems require the all new Collaro—the turntable that changes records—featuring the revolutionary transcription-type tone arm.

The new arm is one-piece, counter-balanced and will take any standard cartridge. Resonances are below the audible level. Between the top and bottom of a stack of records there's a difference of less than 1 gram in the tracking weight as compared with 4 to 8 grams on conventional changers. This insures better performance for your precious records and longer life for your expensive styli.

It's worth noting that Collaro quality is so well recognized that leading American manufacturers of fine console units incorporate Collaro into their instruments in order to achieve the best possible performance in a record player.

In addition to the transcription-type arm, the Collaro Continental features:

Four speeds, manual switch that permits playing single record or portion of a record; jam proof mechanism, hold the arm in mid-cycle and it won't jam; automatic intermix, plays 7", 10"

or 12" records in any order; automatic shut-off after last record has been played; wow and flutter specifications, 1/4 (0.25%) RMS at 33 1/3 RPM, superior to any changer in the world; muting switch and pop filter to eliminate extraneous noises; extra heavy duty 4-pole induction motor; heavy rim-weighted, balanced turntable for fly wheel action; removable heavy rubber turntable mat; pre-wiring for easy installation; attractive two tone color scheme to fit any decor; factory custom-testing for wow, flutter, stylus pressure and correct set-down position. Reflecting their custom English craftsmanship Collaro changers are tropicalized to operate under adverse weather and humidity conditions. The base, in blond or mahogany, is optional at slightly extra cost and the Collaro mounts easily and quickly on a pre-cut mounting board or base.

When you buy your Collaro, you're buying professional quality equipment at a record changer price. Collaro prices start at \$37.50. The Continental, featured above, is \$46.50. (Prices are slightly higher west of the Mississippi.)



**FREE:** Colorful new catalog, containing guide on building record library plus complete Collaro line.

WRITE TO DEPT. A-014.  
ROCKBAR CORPORATION  
MAMARONECK, N. Y.

Rockbar is the American sales representative for Collaro Ltd. and other fine companies.

# Feedback and Distortion

GEORGE FLETCHER COOPER\*

While it is common knowledge that feedback reduces distortion at the same time it reduces gain, it is not always clear why. The author presents the reasoning in a lucid manner.

ALL READERS will be familiar with the basic theoretical result that the distortion produced in an amplifier is reduced by the use of negative feedback, and that the reduction, expressed as the ratio of distortion-with-feedback to distortion-without-feedback, is equal to the reduction of amplification. The feedback which reduces the gain by 20db will bring the distortion down from 5 per cent to 0.5 per cent. It is not difficult to prove this, although I do not propose to put the proof in here. There would seem to be very little more to say on this topic: the only other point of interest, indeed, seems to be that the basic theoretical result turns out in practice not to be true.

A well-established rule in such situations is to distrust practice. There are frequently good reasons why the practical result is unreliable. Two come to the mind at once: the actual feedback network may be producing distortion if carbon composition resistors are used at an excessive level in a really-low-distortion system, or the feedback network may be absorbing an appreciable amount of power, so that the true operating level is higher than the power delivered to the load suggests. Again, the feedback may be positive for the higher harmonics, so that the gain reduction for the fundamental is neither here nor there. This is very likely to happen when you are relying on the feedback to give you a good frequency response from a bad amplifier.

Even when all these sources of error have been eliminated we may still find difficulty in reconciling our practical results with our theory. I do not need to emphasize the fact that this is a very serious state of affairs: if ever the day comes when twice two is quite certainly equal to 3.99 we shall all be in a tight spot. It was because one of Jupiter's moons was not quite on course that we set off on the track towards those bombs. Fortunately our theoretical problems here are rather simpler and the consequences are less alarming.

The theory of distortion in feedback amplifiers is always based on a study of a system which has very little distortion.

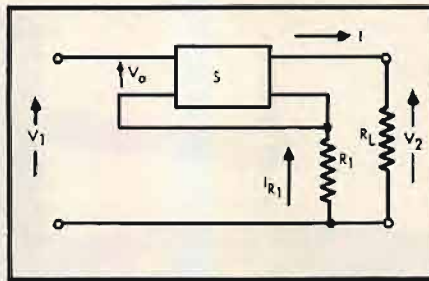

Fig. 1. This particular form of feedback amplifier is used to make the distortion calculation curves. The power into the load is  $I^2R_L$ , so that we are justified in talking of  $Z$  as the output instead of  $AV_2$ .

This is never explicitly stated, but you can see where it creeps in: the distortion is reduced by the same factor as the gain. Now the initial gain cannot be constant or there would not be any distortion. The gain must depend on the instantaneous voltage at the input and rises and falls with the variation of voltage. So, then, does the gain reduction factor and so does the distortion. What happens if you reduce the distortion by a factor which is itself not constant? It seems fair to guess that the fundamental and the distortion will be modulated by themselves and each other. The way is open to a wonderful complex of modulation products and high harmonics. The way is also open to a wonderful complex of mathematics which would be quite unfit for these pages.

## Practical Case

Fortunately it is possible to find a way round. Let us consider the amplifier shown in Fig. 1. This is a particular case of an amplifier having current feedback, drawn in a slightly unusual way. The input is  $V_1$  and the output into the load  $R_L$  is considered to be the current  $I$ . With the more usual symbols, of course, we should consider the output to be  $V_2$ , which is equal to  $IR_L$ . Across the resistor  $R_1$ , the feedback resistor, there is a voltage  $IR_1$  developed. The analysis will be very much easier if it is assumed that  $R_1$  is so much smaller than  $R_2$  that we need not make any allowance for the power developed in  $R_1$ . This will not be too dangerous if the amplifier has a

great deal of voltage, as distinct from power, gain and in any event it does not affect the final result to which we shall proceed.

As usual we write down the actual input to the amplifier itself rather than the whole system. It is  $V_a = V_1 - IR_1$ .

Now we define the gain of the amplifier as a transconductance and we say that

$$G = I/V_a.$$

This is a very fair and proper thing to do if the last tube is a high-impedance tube such as a pentode or a tetrode, and if the last tube is a triode we can quite reasonably do this provided we decide what  $R_L$  is to be and don't alter its value. The effect of feedback is to reduce the amplifier gain to some value  $g'$ , where

$$g' = I/V_1 \\ = I/(V_a + IR_1)$$

From these results we can easily see that we have

$$\frac{1}{g'} = \frac{1}{g} + R_1$$

It may help the reader to consider some typical numbers. A particular loudspeaker amplifier will deliver 3 watts into a 3-ohm load for an input, without feedback connected, of 10 millivolts. Then  $G = 1 \text{ amp}/10 \text{ mv}$  and  $1/g = 0.01 \text{ ohms}$ . With feedback connected an input of 100 mv is needed for the same output, so that  $G' = 1 \text{ amp}/100 \text{ mv}$  and  $1/g' = 0.1 \text{ ohms}$ . It is the simplest of arithmetic operations to derive from this that  $R_1 = 0.09 \text{ ohms}$ . Please do not write and tell me that no-one wants current feedback in a loudspeaker system: this example is just for the numbers.

It will be an interesting exercise to see if we can get anywhere with a simple analysis. I cannot remember seeing this done anywhere, so I shall not be surprised if the answer is quite useless. Suppose that the actual value of  $G$  is  $g_0 + f(v)$  where  $v$  is the voltage at the input terminals of the system and  $g_0$  is the transconductance for very small signals. Then we have

$$\frac{1}{g'} = \frac{1}{g} + R_1 = \frac{1}{g_0 + f(v)} + R_1$$

\* London, England.



**If it's worth Engineers' time . . .**



**. . . It's worth Engineered Cable**



**Belden**

**INTERCOMMUNICATING  
AND  
SOUND SYSTEM CABLES**

Indoor-outdoor, phones  
or speakers—there is a  
Belden engineered cable  
to meet your needs for  
a permanent, trouble-  
free installation.

"Items from the  
Complete Belden Line"

*The TV station, the systems for  
music, paging, and intercom-  
munication in the new  
Prudential Insurance Company  
of America's Building in Chicago  
have been—wired by Belden.*



**Belden**

**WIREMAKER FOR INDUSTRY  
SINCE 1902  
CHICAGO**

2-8

Magnet Wire • Lead and Fixture Wire • Power Supply Cords, Cord Sets and Portable Cord • Aircraft Wires  
Welding Cable • Electrical Household Cords • Electronic Wires • Automotive Wire and Cable

$$= \frac{1 + g_o R_1 + R_1 f(v)}{g_o + f(v)}$$

and

$$G' = \frac{g_o + f(v)}{1 + g_o R_1 + R_1 f(v)} = \frac{1}{1 + g_o R_1} \cdot \left[ 1 + \frac{f(v)}{1 + g_o R_1} \right]^{-1}$$

We know that

$$(1 + x)^{-1} = 1 - x + x^2 \dots$$

so that

$$G' = \frac{g_o}{1 + g_o R_1} + \frac{f(v)}{1 + g_o R_1} - \frac{g_o f(v)}{(1 + g_o R_1)^2} + f^2(v) \left[ \frac{1}{(1 + g_o R_1)^2} + \frac{g_o}{(1 + g_o R_1)^3} \right] + \dots$$

What does all this mean? We introduced  $f(v)$  as the distortion-producing function, the factor showing how the basic gain depends on signal level. The expression for  $G'$  consists of the first term, showing the gain reduced by a factor  $(1 + g_o R_1)$  the second term, showing the distortion reduced by a factor  $(1 + g_o R_1)$  and then a whole string of extra distortion terms which show us that we are going to have to work very hard to extract any useful numerical information.

The box shown in *Fig. 1* is an amplifier containing, we may assume, a number of tube stages in tandem. There is nothing in our theory which is affected by the number of stages, provided always that some device is used to make the feedback negative. We may therefore consider that we have got a single super-tube, even though the 100 amps/volt of the example sounds rather large. That being so, we can go on to draw a transconductance-voltage curve, which may well look something like *Fig. 2*. Unless we are using push-pull output, indeed, *Fig. 2* is a very fair representation of what we usually get because the whole behavior of the system is dominated by the last tube in the chain.

In an article which appeared in a recent number of *AUDIO*<sup>1</sup> I showed how the distortion associated with a particular shape of transconductance curve.

I do not propose to go through all that again but I shall assume that you will either accept the statement I shall make or will check back on this article.

The curve which I have sketched in *Fig. 2* applies to the amplifier without

<sup>1</sup> November, 1957.

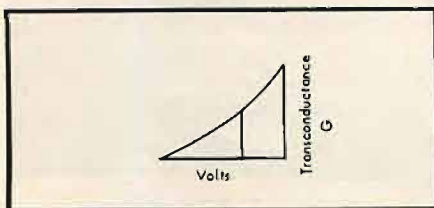

*Fig. 2.* It could be a single tube, but here it is a string of tubes—an amplifier, in fact—which gives us a transconductance-input characteristic.

feedback. It is perfectly possible to construct it from the tube data supplied by the manufacturers if you want to work out a real problem although I don't think it would be really profitable. I myself prefer to check on a stage-by-stage basis, make a rough evaluation of the amounts of positive and negative feedback to be used, allow a really substantial safety margin and then reach the optimum design by direct measurements

on the amplifier. But it is profitable to know how to do it all on paper because it helps so very much in evaluating the experimental results.

### What Feedback Does

Our concern, anyway, is with the effect of feedback. What will feedback do

$$g_o' = g_o / (1 + g_o R_1)$$

where  $g_o'$ ,  $g_o$  are the values for  $G'$  and  $G$  if the signal is very small indeed. We therefore have

$$1 + g_o R_1 = g_o / g_o'$$

or

$$R_1 = \frac{1}{g_o'} - \frac{1}{g_o}$$

Now this last equation can be regarded as a definition of a fictional resistance  $R_1$ , which may or may not appear in the practical circuit. Usually there are reasons for putting a network of resistors in the feedback path, but this trick enables us to say, by carrying out a pair of simple gain measurements, that if there were just one resistor it would be  $R_1$ , and if there isn't, well, the circuit behaves as though there were.

At this point I broke off to construct *Fig. 3*. This is based on an idealized amplifier having a transconductance of

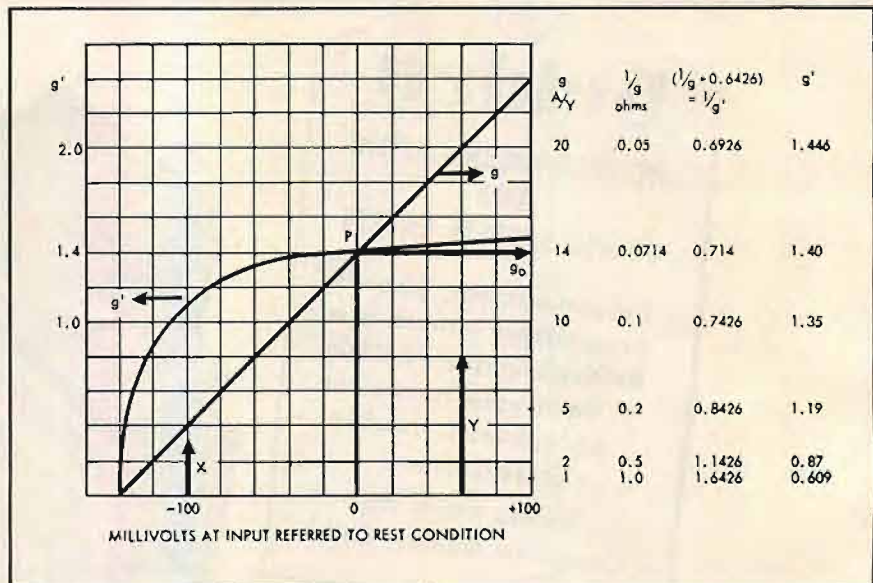

*Fig. 3.* The straight "second-harmonic"  $G$  characteristic is altered to  $G'$  by 20 db of feedback. Details are given in the text.

to the curve in *Fig. 2*? Can we find something which is equivalent but which represents a feedback amplifier? The reader will recognize that these are rhetorical questions, that if the answer to the second question were not yes the question would not have been asked. After all, if we cannot find what feedback does to *Fig. 2* we should hardly have raised the subject at all.

When we are actually using our amplifier we do not think about the feedback: that is inside the box. We think only of the input and output terminals and we say, in the language we have decided to use, that the system has a transconductance of  $G'$ . In the discussion above we showed that

$$\frac{1}{G'} = \frac{1}{g} + R_1$$

and later on we showed, in effect, that

about 14 amps/volt, which means that without feedback you will need 70 mv input to give 3 watts in a 3-ohm load. A fairly typical small amplifier, one might say. I haven't any particular output tube in mind, though a 6AQ5 operated conservatively would give something like this. The transconductance characteristic is assumed to be a straight line, to make matters look rather simpler and to show up an interesting point. At a number of values of input I have marked the corresponding value of  $G$  and have then found, from a table of reciprocals, the value of  $1/g$ . At the reference point  $P$ , for example,  $G$  is 14 A/V, so  $1/g$  is 0.0714 ohms.

Next I have decided that since  $g_o$  is 14 A/V, I will have  $g_o' = 1.4$  A/V. This is exactly 20 db of feedback. As we have

(Continued on page 70)

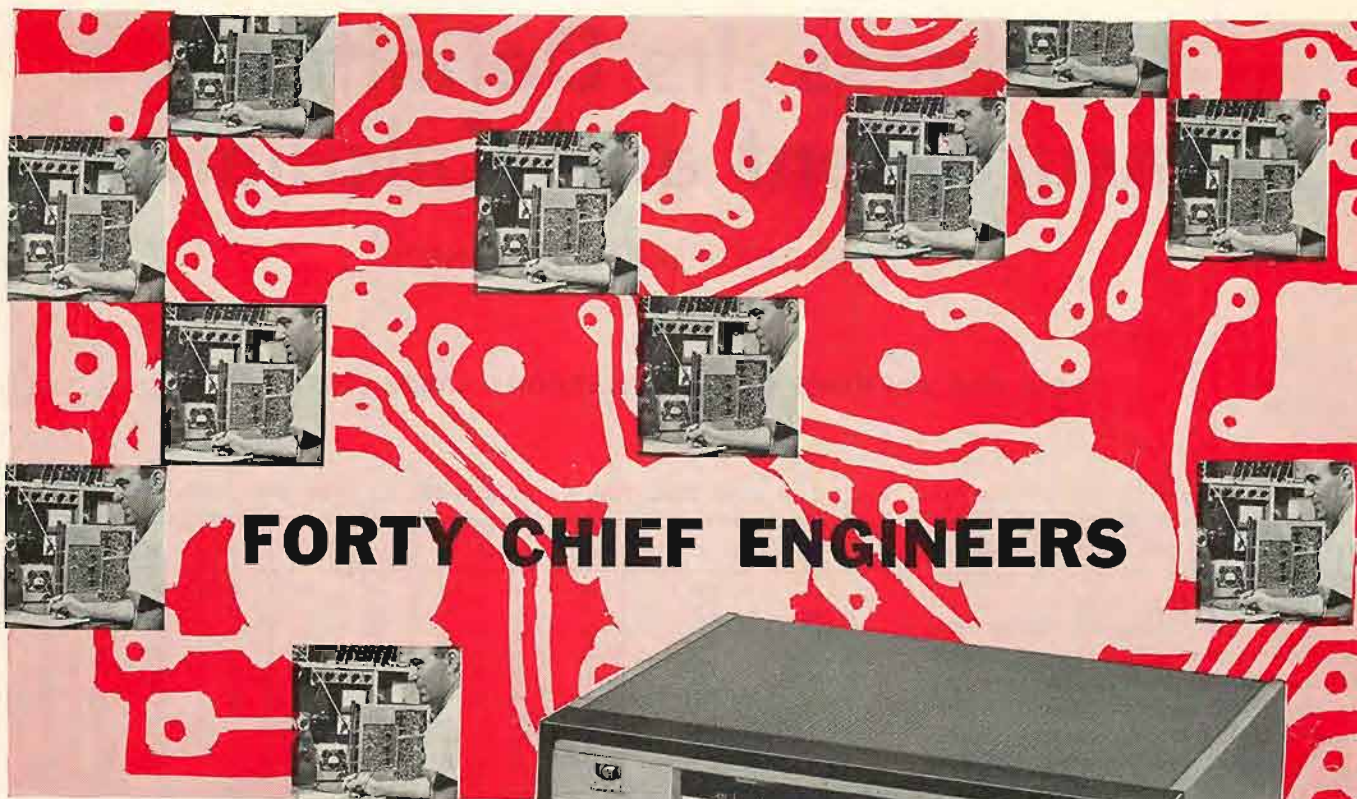

## FORTY CHIEF ENGINEERS

The Recital TA-120, selected by American Society of Industrial Designers for official U.S. display at Milan Triennale -- world's most important exhibition of industrial design



Once the design of a high fidelity tuner or amplifier has been completed, the chief engineer is entirely dependent on how well the factory can reproduce it.

In a sensitive high fidelity instrument, the location of its component parts is extremely important. As little as 1/32 of an inch can make the difference between routine and superb performance. This critical relationship can often be compromised by the conventional production method of hand wiring. Subtle wiring variations, unintentionally introduced by production people, can result in wide variations in performance between sets produced on the same production line.

Were it possible to place the chief engineer at each of our forty final test positions, he could undoubtedly correct those compromises and make each instrument the perfect translation of his design.

Harman-Kardon has, in effect accomplished this objective by the creative application of printed wiring. Its use in every Harman-Kardon tuner and amplifier has virtually eliminated human variables in production. In each instrument every part is in its one best position with respect to every other part and all the interconnecting wires are of precisely the correct length and in precisely the correct place. This is one of the reasons why the Harman-Kardon tuner or amplifier you buy is certain to equal the performance of the original engineering design.

*Printed wiring is the technique which can effect perfect reproduction of the engineer's design every time. The process literally prints the interconnecting wiring of the instrument by etching it on a laminated phenolic sheet. Electrical components are fastened to the sheet by automation equipment and the sheet is then dipped into a bath*

*of solder. In this manner each element is locked into its one best position.*

*This process has been perfected and proved in the U.S. Guided Missile and Earth Satellite programs—and in the production of radar and the new computers. Here, where emphasis is on precision, reliability and quality—and where cost is not a factor—printed wiring is the production choice.*

Typical product of the marriage of creative engineering and ideal production technique is the new Harman-Kardon Recital Model TA-120. It combines a highly sensitive AM-FM tuner, a complete preamplifier and a 20 watt hum-free, distortion-free power amplifier. It features: magnificent Armstrong FM with Automatic Frequency Control to insure accurate tuning automatically; sensitive AM with automatic volume control and built in ferrite antenna; dynamic loudness contour control to provide precise balance for your own hearing characteristics; enormously effective bass and treble tone controls to adjust for the acoustics of your room; selectable record equalization; remote speaker selector switch and rumble filter.

The Recital's "Controlled H" circuit operates so efficiently that it creates less heat than conventional instruments which deliver only half its power output. The enclosure and control panel are finished in brushed copper, the knobs and control panel frame in matte black. The Recital is 14-3/4" wide by 3-5/8" high by 10-15/16" deep. Simply plug in a suitable loudspeaker and record player and a high fidelity system of incomparable performance and unique good looks is yours.

**The Recital Price is \$189.95**

*Slightly higher in the West*

FREE: Colorful, fully illustrated catalog. Describes complete Harman-Kardon line. Includes guides on how and where to buy high fidelity equipment. Send postcard to Harman-Kardon, Dept. A-12, 520 Main St., Westbury, N.Y.

**harman kardon**

# Loudness, Its Definition, Measurement and Calculation

HARVEY FLETCHER and W. A. MUNSON

Part IV

FROM THE ARCHIVES OF BELL TELEPHONE LABORATORIES

To determine when two sounds are equally loud it is necessary to rely upon the judgment of an observer, and this involves of course, not only the ear mechanism, but also associated mental processes, and effectively imbeds the problem in a variety of psychological factors. These difficulties are enhanced by the large variations found in the judgments of different observers, necessitating an investigation conducted on a statistical basis. The method of constant stimuli, wherein the observer listens to fixed levels of the two sounds and estimates which sound is the louder, seemed best adapted to control the many factors involved, when using several observers simultaneously. By means of this method, an observer's part in the test can be readily limited to an indication of his loudness judgment. This is essential as it was found that manipulation of apparatus controls, even though they were not calibrated, or participation in any way other than as a judge of loudness values, introduced undesirable factors which were aggravated by continued use of the same observers over a long period of time. Control of fatigue, memory effects, and the association of an observer's judgments with the results of the tests or with the judgments of other observers could be rigidly maintained with this method, as will be seen from the detailed explanation of the experimental procedure.

The circuit shown in Fig. 15 was em-

125 C.P.S. PURE TONE TEST NO. 4 CREW NO. 1. 1000 C.P.S. VOLTAGE LEVEL (DB)

| Obs.  |    | +6  | +2  | -2  | -6  | -10 | -14 | -18 | -22 | -26 |
|---|----|-----|-----|-----|-----|-----|-----|-----|-----|-----|
| 125<br>c.p.s.<br>Volt.<br>level =<br>+ 9.8 db     | CK | +   | +   | +   | +   | +   | 0   | 0   | 0   | 0   |
|   | AS | +   | +   | +   | +   | 0   | 0   | 0   | 0   | 0   |
|   | DH | +   | +   | 0   | 0   | 0   | 0   | 0   | 0   | 0   |
|   | CK | +   | +   | +   | +   | +   | 0   | 0   | 0   | 0   |
|   | AS | +   | +   | +   | +   | 0   | 0   | 0   | 0   | 0   |
|   | DH | +   | +   | 0   | 0   | +   | 0   | 0   | 0   | 0   |
|   | CK | +   | +   | +   | +   | 0   | 0   | 0   | 0   | 0   |
|   | DH | +   | +   | +   | 0   | 0   | 0   | 0   | 0   | 0   |
|   |    | 0   | -4  | -8  | -12 | -16 | -20 | -24 | -28 | -32 |
| 125<br>c.p.s.<br>Volt.<br>level =<br>- 3.2 db     | CK | +   | +   | +   | +   | 0   | +   | +   | 0   | 0   |
|   | AS | +   | +   | +   | +   | +   | 0   | 0   | 0   | 0   |
|   | DH | +   | +   | +   | +   | 0   | 0   | 0   | 0   | 0   |
|   | CK | +   | +   | +   | +   | +   | +   | +   | 0   | 0   |
|   | AS | +   | +   | +   | +   | +   | +   | 0   | 0   | 0   |
|   | DH | +   | +   | +   | 0   | +   | 0   | +   | 0   | 0   |
|   | CK | +   | +   | +   | +   | +   | +   | 0   | 0   | 0   |
|   | DH | +   | +   | +   | 0   | +   | 0   | 0   | 0   | 0   |
|   |    | -15 | -19 | -23 | -27 | -31 | -35 | -39 | -43 | -47 |
| 125<br>c.p.s.<br>Volt.<br>level =<br>- 14.2<br>db | CK | +   | +   | +   | +   | +   | 0   | 0   | 0   | 0   |
|   | AS | +   | +   | +   | +   | 0   | 0   | 0   | 0   | 0   |
|   | DH | +   | +   | 0   | +   | +   | +   | 0   | 0   | 0   |
|   | CK | 0   | +   | +   | +   | +   | +   | 0   | 0   | 0   |
|   | AS | +   | +   | +   | +   | 0   | +   | 0   | 0   | 0   |
|   | DH | +   | +   | 0   | +   | 0   | 0   | +   | 0   | 0   |
|   | CK | +   | +   | 0   | +   | +   | +   | 0   | 0   | 0   |
|   | DH | +   | +   | 0   | 0   | +   | +   | 0   | 0   | 0   |

Fig. 16. Loudness balance data sheet.

ployed to generate and control the reference tone and the sounds to be measured. Vacuum tube oscillators were

used to generate pure tones, and for complex tones and other sounds, suitable sources were substituted. By means of the voltage measuring circuit and the attenuator, the voltage level (voltage level =  $20 \log V$ ) impressed upon the terminals of the receivers, could be determined. For example, the attenuator, which was calibrated in decibels, was set so that the voltage measuring set indicated 1 volt was being impressed upon the receiver. Then the difference between this setting and any other setting is the voltage level. To obtain the intensity level of the sound we must know the calibration of the receivers.

The observers were seated in a sound-proof booth and were required only to listen and then operate a simple switch.

(Continued on page 65)

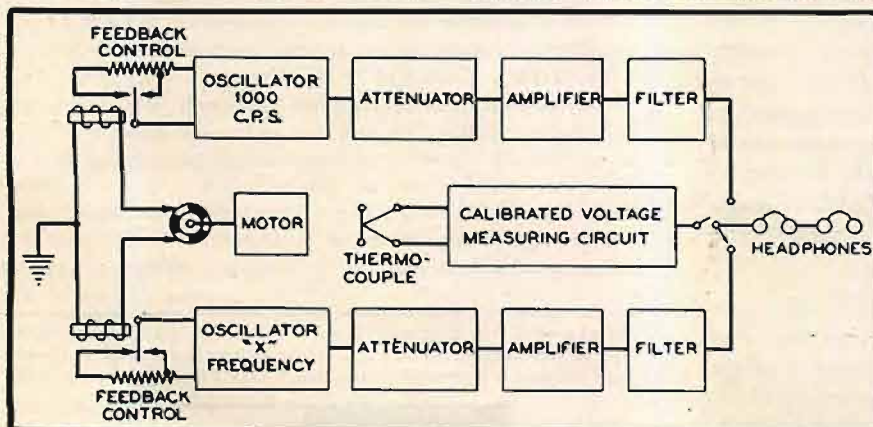
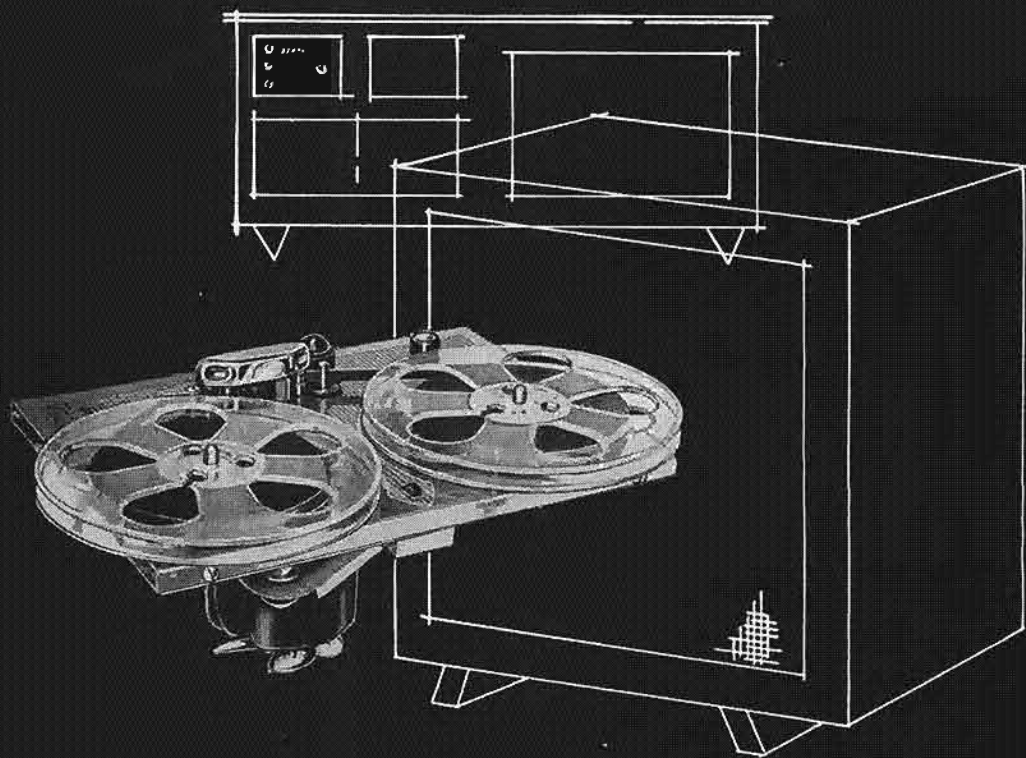

Fig. 15. Circuit for loudness balances.

step  
up  
to  
stereo  
with  
Viking  
tape  
components



#### The component concept

A Viking Stereo Deck can be added to your present hi-fi music system utilizing the amplifiers and speakers you now own. This is the Viking "component" concept. It means you do not need to buy amplifiers or speakers which duplicate the functions of those you already have.

#### Will it record?

Used with the Viking Recording Amplifier, this same stereo deck becomes a recorder and (don't miss this point) as such, actually meets or exceeds the critical NARTB\* standards. *Properly used, the Viking will record and play back recorded material with broadcast quality, and at a home recorder price.*

#### Stereo recording

Viking provides not only in-line stereo recording, but simultaneous dual channel erase — virtually a Viking exclusive. No need for bulk erasing of tapes, or a "double-pass" erase. The new Viking FF75ES Deck provides dual erase heads. Used with synchronized Viking RP61 Recording Amplifiers, you can record original material in stereo, copy tapes, or record from stereo broadcasts with the same full-fidelity which characterizes Viking monaural recorders. (Erase bias oscillators must be synchronized to prevent heterodyne.)

#### Don't just compare specifications — compare performance

Hear the difference in recording capabilities, in signal-to-noise ratio and overall frequency response.

Your dealer will help you with integration of Viking components with your present system . . . or write direct to Viking's Customer Service Department for suggestions. Free stereo literature and catalogs available on request.

\* National Association of Radio and Television Broadcasters

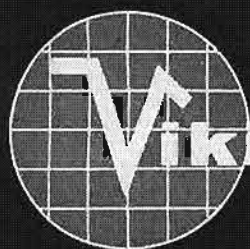

**Viking** OF MINNEAPOLIS

9600 Aldrich Avenue South, Minneapolis 20, Minnesota

EXPORT DIVISION: 23 Warren Street, New York City 7, New York  
Cable: SIMONRICE, New York (All Codes)

IN CANADA: Alex L. Clark, Ltd., 3745 Bloor St. W., Toronto 18, Ontario

# Equipment Review

ISI Model A-10 loudspeaker—Connoisseur magnetic pickup—Sargent-Rayment Model 300-M70 tuner-amplifier combination

FROM THE TIME the first of the small high-quality loudspeaker enclosures was introduced, it was only a matter of time until the market would be flooded with variations and—in many instances—improvement. This, of course, is hindsight, but one is more likely to be right when looking back than when he is looking forward. There can be no doubt that there is a big demand for enclosures which employ some engineering advances to obtain quality which heretofore had been available only with large and bulky cabinets. And in many instances, these advances have resulted in cabinets or complete loudspeaker systems which offered other advantages than mere smallness of size.

The Model A-10 produced by International Scientific Industries Corporation is an outstanding example of a compact speaker system, and it is considerably less expensive than many other units of similar size and design intent. We have had an opportunity of "living with" a pair of Model A-10's for the last few months, and when driven with adequate power they are excellent performers.

Our initial experience was when we first connected one of these units to the 4-ohm output of good-quality TV receiver—with a single 6V6 output stage. Performance was anything but acceptable, mainly due, as we know now, to lack of sufficient driving power. In order to obtain suitable listening volume the 6V6 was being driven into overload, and the distortion was terrific. Then we connected one of these units to a Dynakit III, and it might have been an entirely different speaker.

Our requirement for a portable speaker system for a stereo demonstration lecture caused us to assemble two Dynakits into a single "package" for ease in carrying, and to use two of the A-10's. The sound source was a Tandberg Stereo 3 tape recorder. We were most favorably impressed with the entire system, and even when the speakers were well away from the wall—much less a corner—the bass was solid and pleasant.

The A-10, shown in Fig. 1, is only 22½ in. high, 14 in. wide, and 9¾ in. deep. It employs two speaker units—a 12-inch low-frequency driver with a specially treated cone of lower-than-normal free-air resonance, and a 5-inch high-frequency driver selected for smooth response, and sealed at the rear to eliminate the effects of the woofer back wave. The woofer is loaded in the rear by a completely enclosed compartment, and the front wave is channeled through a circuitous path with an aperture considerably smaller than the cone area. This would seem to provide a solid load on both sides of the

cone throughout the entire frequency range.

Listening tests (we make no "absolute" measurements on loudspeakers) show response down to 30–35 cps without any apparent doubling. Like most of the highly controlled, fully enclosed speaker systems, the A-10 seems to be deficient in bass when switching directly from another type of speaker on an A-B test. However, after listening to the A-10 for a while and then switching back to the other type, the coloration of the other shows up quite noticeably, while the A-10 seems to have perfectly adequate bass and to be smooth and free from any coloration of its own.

The A-10 is not an efficient speaker—we would estimate it to be about 10 or 12 db below a conventional bass-reflex housing with a high-quality 12-inch cone. But in this age of 30 to 50 watts, or more, in the power amplifier, this is no longer a problem, and if the quality obtained from the speaker can compare more than favorably with that from bulkier yet more efficient models, the added power can be had from any one of the buskier amplifiers with little trouble.

For stereophonic use, the small size of the A-10 is certainly a big advantage. We did find that the low height of these speakers makes it necessary that they be placed on something to raise them from the floor. But under the proper conditions of use, these speakers are convenient and certainly good enough in performance for almost any application. B-20

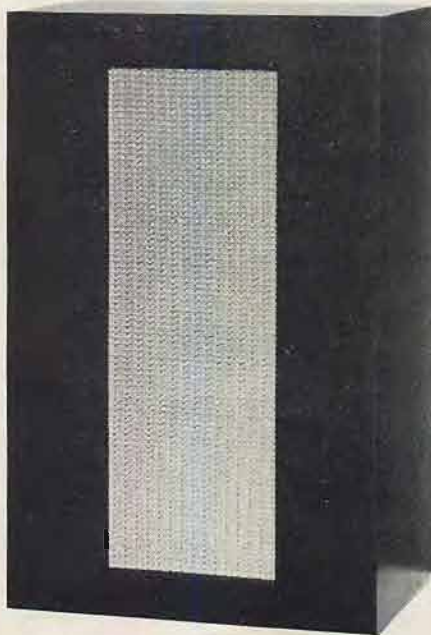

Fig. 1. ISI A-10 loudspeaker system.

## CONNOISSEUR MAGNETIC PHONO PICKUP

In this department for February, 1957, we reviewed the Connoisseur turntable, which we indicated was an excellent product. One reader has since called our attention to the fact that the stroboscope disc furnished with the turntable had only 158 lines instead of 160 in the 45-rpm ring, and that therefore the speed was not as accurate on 45 as our review would have indicated. The speed on 45 was correct as indicated by the stroboscope furnished with the turntable, but not when indicated by a disc with the proper number of lines. It would be about 1.1 per cent high, or 45.5 rpm. For this reminder we stand corrected. Who would expect a stroboscope disc to have the wrong number of lines? (For the record, the number of lines on a stroboscope disc should be equal to  $120f/(rpm)$ , where  $f$  is the power line frequency in cps. Thus for a 60-cps power frequency, the number of lines for 78.26, 45, and 33.33 rpm, respectively, should be 91, 160, and 216.)

At the time of this review, however, we also had a Connoisseur pickup, but space did not permit us to include it in that issue. As a reminder, we were recently sent another, so we have had an opportunity of checking *two* of a product rather than the usual one.

The Connoisseur pickup is designed to work with its own arm—both being shown in Fig. 2—and each pickup head is equipped with a single stylus. The color of the head indicates the tip radius—red for microgroove, green for modern 78's, with a .0025 in. radius on the tip, and yellow for older 78's, with a .003 in. tip radius. This ensures ready recognition of the correct pickup to use.

All models have the same output impedance—400 ohms—which is relatively low. The output, however, is above the median for magnetic pickups, and measures at 2.7 mv/cm/sec. Most pickups are rated for a stylus velocity of either 5.5 cm/sec or 10 cm/sec, and for direct comparison the outputs at these velocities are 15 and 27 mv respectively. The pickups are intended to work into a high impedance, with 10,000 ohms as a nominal value. Trimming of the top-end frequency response can be done readily by varying the load impedance.

Using a 78-rpm Cook Series 10 frequency test record, we measured the response of the two pickups at hand. The curves indicate close tolerance between them, being of the order of  $\pm 3$  db through-

something wonderful has happened in high fidelity



## a record changer with turntable quality performance

The new Glaser-Steers GS Seventy Seven made its debut at the 1957 New York High Fidelity Show. Thousands of people filed through the demonstration rooms to see and hear it perform.

Response was sensational. Listeners were astounded at the quality of the sound — the absence of wow and flutter, and — the absence of rumble, even with the bass sharply boosted.

Three GS-77 features received the most comment: Speedminder, Turntable Pause, and the Tone Arm.

**SPEEDMINDER** is the super automatic setting on the speed selector knob at which the user has virtually nothing to do but place the records on the spindle and select the correct stylus.

With the standard groove stylus in position, the changer automatically plays at 78rpm. With the microgroove stylus in position the changer automatically operates at 33½ and 45rpm, playing both speed records intermixed in any sequence.

**SPEEDMINDER** also protects both stylus and record, for you can detect immediately if you are using the incorrect stylus.

The changer can also be 'dialed' to play 16⅓, 33⅓, 45 or 78rpm, automatically or manually.

**TURNTABLE PAUSE** brings to the automatic GS-77 all the gentleness of record handling associated with manual turntables. In the GS-77 — and only in the GS-77 — the turntable pauses during the change cycle and resumes motion only after the stylus is in the run-in groove of the next record.

This eliminates the surface grinding which takes place in conventional changers where the record drops onto a rotating record. Turntable Pause protects your records, and adds many, many plays to their useful life.

The **TONE ARM** of the GS-77 is another example of precision engineering — evident from the very moment you lift and handle it. Movement, laterally as well as

vertically, is as smooth and free from friction drag as you'd expect in a high quality transcription arm.

Fundamental resonance of the arm is well below the audio band, and of extremely low amplitude. Acoustical isolation is also used to prevent vibration feedback through the arm pivot.

Dynamically balanced on hardened steel pin bearings, the arm will track at low stylus pressures recommended for modern cartridges. And stylus pressure between the first and tenth record in a stack will not vary beyond 0.9 gram.

... and there is much, much more!

See *all* the GS-77 features! See the advanced, years-ahead styling. See why music lovers everywhere hail this American contribution to high fidelity.

\$59.50 less cartridge

For descriptive literature, write: A-2  
GLASER-STEERS CORPORATION  
20 Main Street, Belleville 9, New Jersey  
In Canada: Glaser-Steers of Canada, Ltd., Trenton, Ont.  
Export: M. Simons & Sons Co., Inc., N. Y. 7.

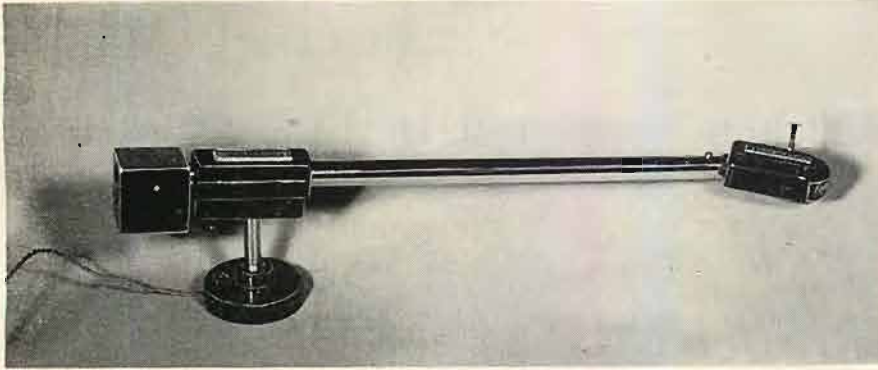

Fig. 2. Connoisseur magnetic pickup and arm.

out. Both showed a peak of about 2 db, one at 15,000 cps and the other at 12,000 cps. However, by varying the load resistance, both could be made to match and to reduce the peak to the 1000-cps level with some drooping of response above the peak frequency.

At the other end of the frequency spectrum, we observed that both of the pickups could track the Cook record down to 20 cps without any chattering or without deviation of the output from a pure sine wave. This test shows up insufficient stylus force or lack of compliance quite readily. The normal stylus force used with the Connoisseur pickup is 6 grams, with a small variation being obtainable by moving the counterweight in or out as required. Specifications indicate that the 78-rpm pickups require some 7 to 8 grams for proper tracking.

The construction of the pickup is such that the stylus assembly may be replaced easily by the user, yet not so easily that there would be any possibility of the stylus not being in the proper playing position. The armature is suspended on a nylon thread in a fore-and-aft direction so as to give a high compliance yet restraining the stylus motion along the groove. Vertical compliance permits the stylus to retract into the case if the pickup should happen to be dropped onto the record, and no damage would result to either record or stylus.

The arm is typical of British construction, with the simplest possible pivot assembly. The unit is attractive in appearance with its highly polished chrome-plated counterweight and tube and black molded base and body. It is short enough to permit mounting directly on the Connoisseur turntable, which is drilled for it, or on most other types of turntables. It would be difficult to mount the pickup in a record changer head, although it could be done by anyone handy with tools and accustomed to small precise work.

Listening quality is considered good, with no objectionable coloration noticed as a result of the peak above 12,000 cps. We have listened to pickups which were anything but flat in the very high range, and the peak is always noticeable. We found that the best load resistance for a compromise for the two pickups was 4700 ohms, but quality was still good with the usual input impedance of preamps—47,000 cps. **B-21**

### SARGENT-RAYMENT 300-M70 TUNER-AMPLIFIER COMBINATION

As may be recalled from years back, we have long been enthusiastic about the Sargent-Rayment line of tuners—their earlier SR-58 being far and away the best AM-only tuner we have ever heard with the exception of the Miller Wide-Range circuit which was available only as a kit some years ago. The SR-68, an AM-FM tuner was practically the Cadillac of tuners.

In keeping with the trend toward smaller and more compact models—and also toward table-top housings, S-R has recently introduced a series of tuners and amplifiers of unusual physical design which are well suited to current decorating schemes. As seen in Fig. 3 the tuner is shown with a conventional front panel to permit installation in the usual type of cabinet. However, when the user wishes to have the tuner in a table-top cabinet, he simply purchases the cabinet and the conversion panel, removes the console panel and ends up with the sloping front "cantilevered" cabinet. This arrangement is attractive, and provides two possibilities for use.

There are three series of tuners—the SR-100, which is just a tuner, but equipped with a volume control and a bandwidth selector to give high-fidelity AM reception; the SR-200, which is combined in one cabinet with a 25-watt amplifier; and the SR-300-M70, which has the tuner with preamp and tone controls in one unit, and a 70-

watt power amplifier in the second section. Power for the tuner comes from the amplifier unit, eliminating high a.c. fields and the heat-producing rectifiers and output tubes from the tuner chassis.

The tuner itself is attractive in appearance and performs well. Sensitivity is rated at 3  $\mu$ v for 20 db quieting, and the manufacturer gives distortion figures, which in itself is unusual, that indicate excellent performance. Listening quality is outstandingly good on FM, and about normal on AM. Provision is made for FM, crystal, and magnetic cartridges, with three equalization positions available—AES, LP, and RIAA.

The 70-watt amplifier employs the British-made KT-88's in an Ultra-Linear output stage with fixed bias and a balancing control. Tube currents can be metered separately, and output impedances of 4, 8, and 16 ohms are available. The first stage is an EF-86, and it is directly coupled to the input grid of a 6SN7 in the familiar "long-tailed pair" phase splitter circuit—a modification of the circuit generally referred to as the Mullard, but basically the same as that used in the Leak TL/12 amplifier, which is some eight years old, at least. Plate power is furnished by two GZ-34's, and resistance-capacitance filtering is used for all the lower-voltage stages. Hum level was measured at 58 db below 1 watt, which is slightly better than the 90 db below rated output which is claimed by the manufacturer.

The tuner connects to the power amplifier through a 4-foot cable which is equipped with octal plugs and receptacles, and additional lengths are available for installations where the tuner is required to be further from the amplifier than the original cable allows.

The tuner tone controls are effective, and we particularly like the loudness control, which is a small handle rotating around the volume-control knob. We are still firmly of the belief that some loudness contouring is essential to any good home music system today, and to be effective it must be easy to handle and must be contoured to match the ear's response. However, there are many people who do not share this opinion—at least the fact that both flat and contoured controls are available give the listener his choice. **B-22**

Fig. 3. Sargent-Rayment 300-M70 tuner and amplifier combination.

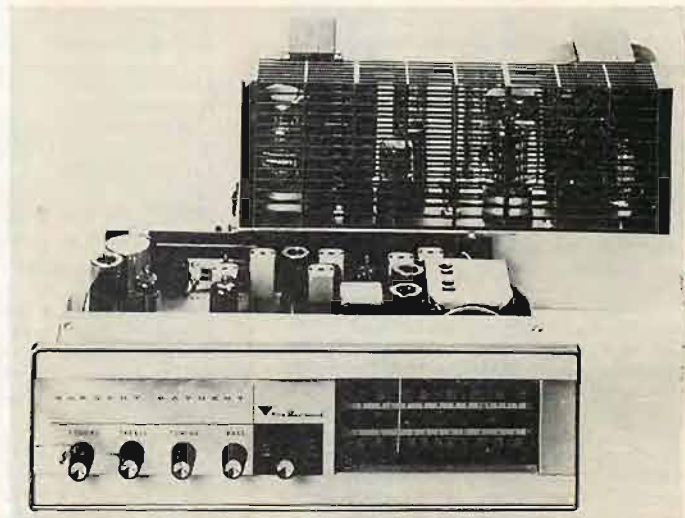

## INCREDIBLE BUT TRUE!

Here at last is luxurious "big system" performance from handsome, convenient-to-place enclosures that are *fully 40 to 80% smaller* than previously available systems of similar performance standards!

Here at last from a small-space system comes *authentic, distortion-free* bass reproduction that's effective at *low volume* as well as at higher levels.

Do NOT confuse University ultra linear response systems with other small units that offer an acoustic compromise. The S-10 2-way systems and S-11 3-way systems employ newly designed, specially high-compliant woofers, free from artificial resonances that "mask" bass deficiency. Mid-range and treble performance is balanced to assure completely flat response to beyond audibility.

Though you will need about 20-25 clean watts to drive them, the S-10 and S-11 eliminate excessive power demands, especially on transient peaks. Hence, you get *cleaner* performance from them than from other similar type systems.

Yes, here is the "impossible" brought to miraculous tonal reality . . . small systems that leave *nothing* to be desired in musical performance . . . so faithful that you can listen hour after hour, relaxed, and without "ear fatigue."

*Hear these systems now . . . at your dealer . . . and learn that finally there is a genuine answer to the problem of obtaining "big sound" in small space!*

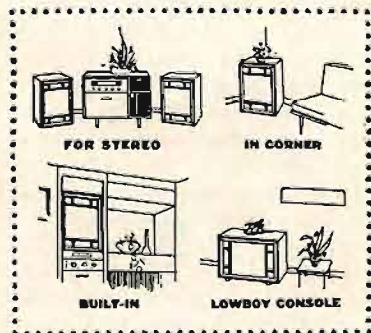

For complete technical story on the S-10 and S-11 ultra linear response systems as reprinted from Radio & TV News, write Desk R-1.

### Models S-10H and S-10L 2-Way System Consolettes

For use where space is most restricted. Only 25" x 14" x 14½" deep; removable base adds 1½". The new C-12HC 12" high compliance, low resonance woofer is employed with special UL/HC wide-angle tweeter (2500 cps crossover) and matched-level crossover network with high frequency balance adjustment. Takes power input of 25-60 clean watts. 8 ohms impedance. Extra-dense ¾" thick double-braced construction; beautiful natural grain, hand-rubbed finish. S-10H is upright model; S-10L, lowboy. User net: Mahogany—\$139, Blond—\$143, Walnut—\$147.

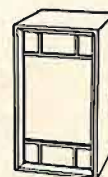

MODEL S-10H

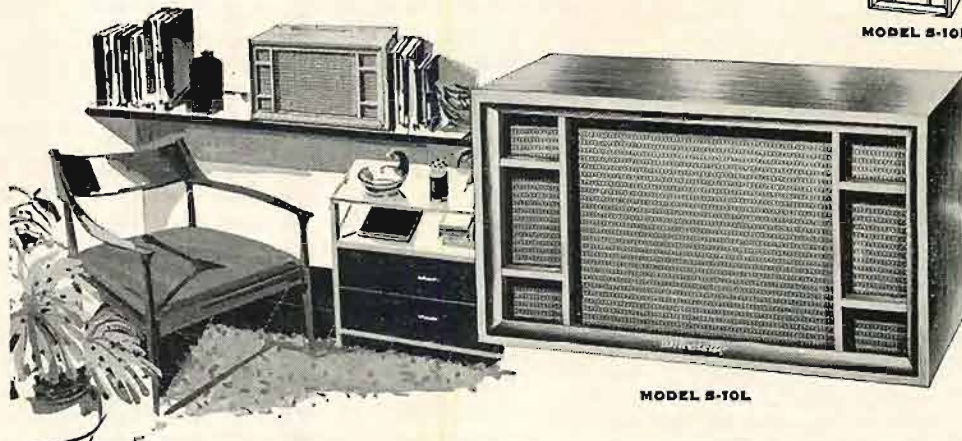

MODEL S-10L

**NEW!**

# University

## ULTRA LINEAR RESPONSE SYSTEMS

### Models S-10 and S-11

Protected by Patent Nos. 2,641,329; 2,690,231 and other patents pending

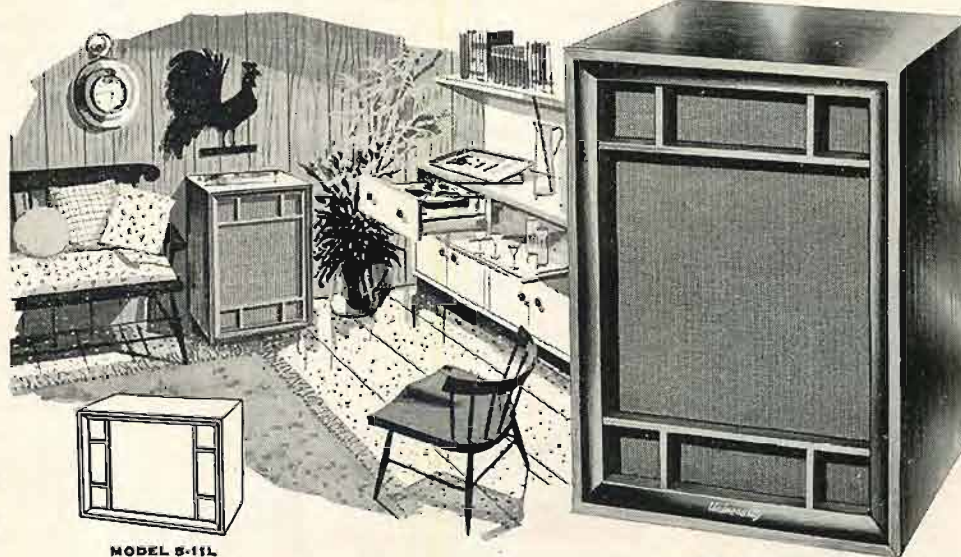

MODEL S-11L

MODEL S-11H

### Models S-11H and S-11L 3-Way System Consolettes

Unusually small size is achieved by coupling University's new ducted annular relief enclosure to the new heavy duty high compliance 15" C-15HC woofer. Special HC-3 matched-level network with "Presence" and "Brilliance" balance controls integrates the Diffuscone-8 in its own compression chamber for mid-range (500 cps crossover) with special UL/HC Hypersonic Tweeter (2500 cps crossover) for response to beyond the limits of hearing range. Takes power input of 20-60 clean watts. 8 ohms impedance. Extra-dense ¾" thick double-braced construction, fine-furniture finish and styling. 26½" x 19½" x 17½" deep; removable base adds 2". S-11H is upright model; S-11L, lowboy. User net: Mahogany—\$245, Blond—\$249, Walnut—\$253.

LISTEN

*University sounds better*



UNIVERSITY LOUDSPEAKERS, INC., 80 SOUTH KENSICO AVENUE, WHITE PLAINS, N. Y.

## STEREO PICKUP

(from page 19)

in the cartridge case, with the tips toward each other. Some filing may be necessary here, and when completed the opening between the two tips should be about  $1/32$  in. wide. Slip the coils down over the pole pieces carefully, keeping the common lead around the outer side of the coil, and dressing the two outside leads back into their respective grooves in the center portion of the case. Replace the smaller of the U-shaped pole-piece tops, and follow with the larger one. Replace the magnet.

Using the small pieces of wax removed earlier, apply heat and seal in the coils, magnet, and the common coil lead. Enough should be used to fill up the spaces around the coils thoroughly. Now recheck the shaping of the pole piece tips, and trim up so they are uniform.

Next, clip off one end of the stylus holder, as shown in Fig. 11. This permits clearing the pole pieces. Slide the stylus assembly into the holder, and insert the holder into the cartridge case. The vanes should be symmetrically disposed on each side of the pole piece tips. Minor adjustments can be made using a pair of sharp-pointed tweezers along the vertical portion of the stylus bar to bend the bar slightly to one side or the other.

After checking the vane and stylus assembly, remove it and lay aside so as to check the common pole piece unit. Slip this part over the end of the cartridge case and check for symmetrical placement of the pole tips with respect to the inside tips already in place. Both

pairs of tips should be parallel, and the space between them from  $5/64$  to  $3/32$  in. Using a small file again, trim up the pole tips so they are symmetrical. When this is completed, remove the common pole piece and replace the stylus holder and stylus assembly. Again check the center pole piece for symmetry around the vanes, making final adjustments by bending the stylus bar so the two vanes are centered in the gaps.

Using a good cement, such as General Cement's "Pliobond," coat the end of the cartridge case and the flattened portion where the pole tips rest on the case, and replace the center pole piece. Clamp in place and allow to dry thoroughly—for an hour or so.

### Final Assembly

Bend up the lug on the electrostatic shield—and it will snap off. Solder a small lug onto the shield at the back, extending beyond the end about  $1/4$  in. Holding the shield and the insulator together, drill a small hole (#55 drill) through both just in front of the larger center hole, and cement the two pieces together.

After the pole piece cement is thoroughly dried, thread the center lead through the small holes in the shield and dress toward the back. Then take the front shield and coat the inside of it with cement and place over the end of the cartridge case, making sure that the sides of the slot in the bottom clear the pole pieces. When this is pushed firmly in place, bend over the three

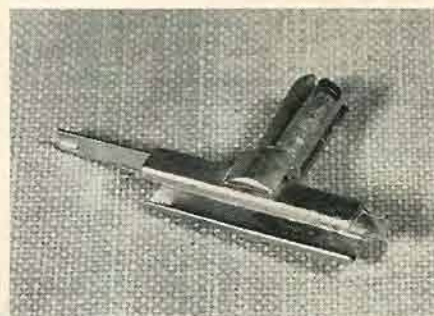

Fig. 11. Stylus assembly holder has one leg cut off to clear pole pieces.

tabs tightly and solder the one at the front to the top shield, which has been coated on the under side with more cement. Wrap the lead around the lug and solder quickly so as not to loosen the solder holding the lug to the shield. Now take the tiny rubber damping block which was removed from the stylus assembly before welding the vane in place, coat the two ends with rubber-to-metal cement, and fit it under the stylus tip with the bottom end wedged between the center pole pieces. When properly fitted the stylus bar should rest firmly against the block, which is cemented at both ends. This completes the modification. The small spring in the hole at the center seems not to be necessary, and may be eliminated. The shield is now the common lead and is grounded; the two plugs normally used are the "hot" leads from the two channels.

The heads of most record changers are equipped with three terminals—one often being used as a ground. Connect the common lead to this terminal, and connect the other two leads to the plugs for insertion into the jacks at the rear of the pickup. It may be necessary to run a new set of leads down through the arm to the terminal block, depending on the type of changer or arm being used. Some use a single shielded wire, which must be changed; others use a shielded pair, and the shield may be used for the common lead.

The two outputs should be fed to two separate phono preamps. The output signal will be found to be approximately one fourth that of the normal pickup before modification. As previously mentioned, some hum may be observed, but for purposes of experimentation the output of the pickup will be sufficiently above the hum level that a satisfactory stereo results will be obtained.

We had considerable fun—after some of the headaches were overcome—in making these conversions, and the results were at least good enough to justify the trouble. If one has occasion to make three or four of these pickup conversions, it will become quite simple and straightforward. Æ

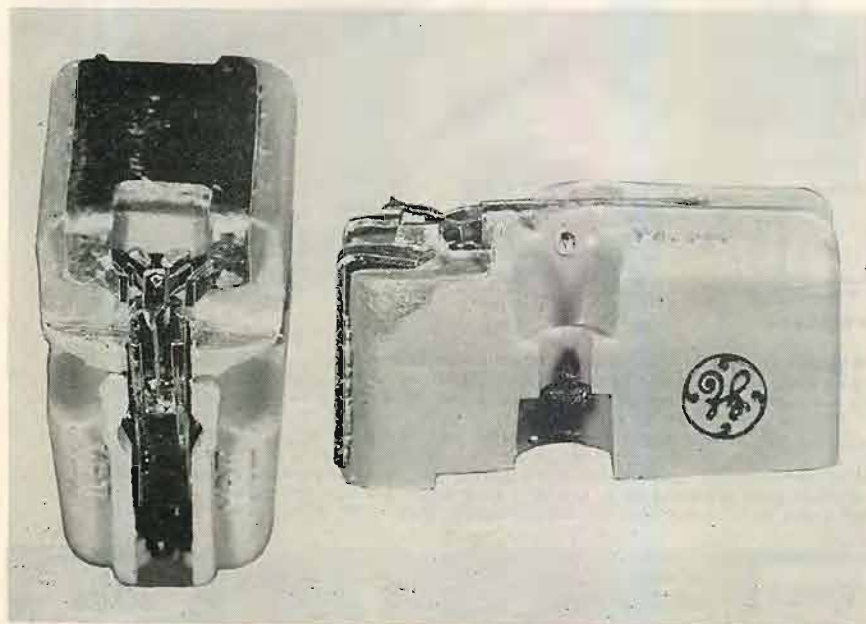
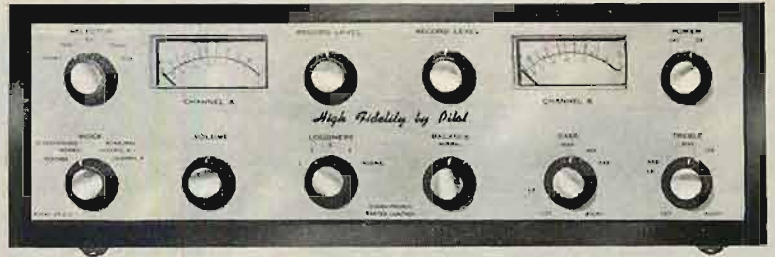

Fig. 12. Front and side views of modified cartridge before replacing front shield.

SP-215 STEREO PREAMPLIFIER



# NOW...

## *stereophonic*

# HIGH FIDELITY

by **Pilot**

SM-244 STEREO PREAMP AND AMPLIFIER



### **Pilot** SP-215 and SM-244 Stereo Components

With the announcement of the SP-215 and the SM-244, Pilot brings to stereophonic sound a caliber of engineering skill that has become a byword in high fidelity. Designed especially for stereophonic high fidelity, these new bi-channel components provide the finely matched quality performance essential for good stereo.

The SP-215 is a complete stereo preamp and audio control system. It is in effect, two matched control-preamps housed in one enclosure. Versatile beyond anything known today, the SP-215 may be used with any stereo signal source: FM-AM stereo broadcasts, stereo tapes and stereo discs. A separate output is provided for making stereo tape recordings from any of these program sources as well as with microphones. Two panel-mounted VU meters permit each channel to be precisely monitored for the recording. And there are independent controls for adjusting the reference and peak recording levels on each channel. The SP-215 may also be used for conventional, non-stereo high fidelity.

Features of the SP-215 include bass and treble controls, volume and loudness controls, as well as a balance control for equalizing the level between the two channels. The SP-215 outputs may

be fed into any two basic power amplifiers, such as the Pilot AA-908 or Pilot AA-410A. Both power amplifiers are operative, and the available power output is the sum of both. Pilot SP-215 Stereo Control-Preamp System complete in enclosure \$189.50.

The SM-244 is a complete stereo control-preamp and amplifier system, all housed in one enclosure. The two built-power amplifiers are rated at 14 watts each (28 watts peak each) at less than 1% distortion. Inputs are provided for FM-AM stereo, stereo tape and stereo discs, microphones, auxiliary, and a separate output for making stereo tape recordings. There are bass and treble controls, volume and loudness controls, plus a balance control as on the SP-215. Whether used as a stereo or non-stereo system, the SM-244 provides an available peak power of 56 watts. Pilot SM-244 Stereo Control-Preamp-Amplifier System, complete in enclosure \$189.50—prices slightly higher in west.

Hear these new Pilot stereo components at your hi-fi dealer today! For complete specifications, write to: Pilot Radio Corp. 37-06 36th St., L. I. City 1, N. Y. *Manufacturers in electronics for over 39 years.*



## EDWARD TATNALL CANBY\*

(Note: I've been trying to complete a new book on hi-fi and because hi-fi itself keeps running ahead of me, I offer a short-end contribution to Record Revue this month—with the firm intention of making amends in future issues, ETC.)

**Saint-Saens: Symphony #3, with Organ.** Phila. Orch., Ormandy; E. Power Biggs, organ. **Columbia ML 5212**

Here was the grand hi-fi symphony of the early LP years as many an audio fan will remember, and it was in a Columbia recording, too. Who doesn't recall those fabulous low organ notes in the second movement of the old recording?

Well, plain fact is that low organ bass was the last thing that interested old Saint-Saens in this music and Columbia has evidently bowed to superior musicological information here—this disc is hi-fi, but not because of those organ notes. You can hardly hear them—and you shouldn't. Not important, musically.

On the other hand, this disc seems to highlight a distinct change in Columbia policy as to mike technique. Do I detect sharp, edgy brass, steely close-up strings—from *Columbia*? That company has stuck doggedly to the old fashioned expansive sort of recording, with fervent thanks from many record buyers who like their music straight and get all the hi-fi they want from other companies. Now, it seems, Columbia is moving in close, to capture a bit of the hi-fi for itself.

It'll do, but I don't feel it is any great improvement on the excellent distant-style technique so well perfected by Columbia. However, time and familiarity will tell us; perhaps this is the new and ideal middle ground. Try it, if you want to see where Columbia is heading. In any case, the Philles under Ormandy do an exciting and rather tense job of the outer movements here; the slow movement (the one without the famous bass notes) is a bit on the non-expressive side in detail; the old Columbia version made more of the music.

(Note: Record jacket says Allen Organ; instrument is Aeolian-Skinner. Symphony Hall, Boston. Ed.)

**Schoenberg: Verklarte Nacht, Op. 4; Chamber Symphony, Op. 9.** S. W. German Radio Symphony, Horenstein. **Vox PL 10.460**

There's been a great retrospective burst of Schoenberg recording lately and this fits in with a whole series of recent Columbia recordings that I haven't been able to absorb yet to the point of emitting words on my typewriter about them. (It takes time, brother.) One reason is that Schoenberg, acknowledged as one of the great 20th century innovators, was a dogmatic, violent personality whose music just plain rubs me the wrong way in many spots—I just don't like Mr. Schoenberg himself, as he so very positively expresses

himself through his music. I can't avoid him as an individual, as I listen to him. And especially, I find myself irritated by a peculiar banality of style, almost a deliberate cheapness, that crops up again and again, in the music recorded here as well as in plenty that is more modern.

Hard to describe—and I've already said enough to rend myself out of the party forever. It's just that Mr. Schoenberg seems (to me) to keep saying, *I am Schoenberg; I can do anything and it's all right.* Funny thing is, maybe he can. But he still makes me sore.

Anyhow . . . these are two early works and important ones. The "Transfigured Night" is familiar to most of us, a long post-Romantic piece that carries the Wagner-Strauss idiom to a near-breaking point of extreme passionate expression; its significance to me is the signs of positive disintegration in the late-Romantic idiom itself, the harmony and color and line and melody—and the other piece, a few years later, shows that idiom virtually reduced to a powerful atonalism. This was an inevitable step, if you wish, in the development of the Schoenberg twelve-tone principle, so important today.

It's still likely that you'll swoon with ecstacy at "Verklarte Nacht" in the general fashion of a good cry with "Tristan"; but the Chamber Symphony will probably carry things a step too far for you in the same direction; it begins to seem something more than a nightmare, a Romanticism somehow become hysteria. But the small orchestra, with interesting solo-sound texture, the greater concentration, are purely modern improvements—and this was 1906. A good recording and authoritatively played.

**Stravinsky: Agon (ballet, 1953-57); Canticum Sacrum (1955-56).** Los Angeles Festival Orch. and Chorus, soloists, Stravinsky. **Columbia ML 5215**

I hasten to trot out this new disc, though I haven't absorbed its second side yet, because it shows in "Agon" how even old Stravinsky is coming about to experiment (if that is the word for such a wonderfully polished and highly developed musical structure) with the Schoenberg principles.

"Agon," for smallest ensemble including of all things, a mandolin, is an arresting and difficult work of severe but mobile expressiveness which, though you may not find it "likeable"—Stravinsky isn't often that—will grasp at your attention and keep it, one way or the other, by sheer musical force.

Stravinsky's strong personality, too, is apt to irk many a listener. You can see it in his familiar face, strong, lean, cold, but with an inner warmth that (for me, again) often comes through in his music if only in the splendid sense of design and order it contains. It is, remember, French-Russian music, in contrast to the blatant German-ness of Schoenberg; mere differences in harmony or structural technique, no matter how far-reaching, can never hide these pervasive traits of

nationality. The French (and Russians) sense design naturally; it is an essential of thought. The Germans come to it by sheer will power; they forge it and keep on forging it, ever bigger and bigger, as though they could not get enough of it. . . .

So it is remarkable that this "Agon" score, following clearly in the Stravinsky manner after so many earlier ones, is radically changed in an ultimate respect; it is again violently dissonant but in a new and Schoenbergian way, carrying Schoenberg's approach (for me) to an unfathomable new synthesis of seeming opposites. That's Stravinsky all over. I dare you to try the record.

**Beethoven: Symphony #5. Schubert: "Unfinished" Symphony.** Vienna State Opera Orchestra, Prohaska. **Vanguard SRV 106**

This is a new Vanguard hi-fi demonstration record and though I generally deplore the use of this eternal pair of familiar symphonies for everything and anything that comes along, I must quickly admit that, hi-fi or no, this is a fine record. I like it.

The fi, first of all, is hi. The recording technique is ultra-modern, which means mainly ultra-close but carefully calculated for balance. It isn't Beethoven as he's been heard in the past, nor Schubert; there are startling inner voices, a few feet from your nose, that are usually but slightly audible in the general rush of orchestral sound and practically inaudible in the concert hall—Beethoven wrote them that way, as parts of the supporting musical structure. There is a tympani department here that will make you jump each time the man sets off a roll or a bang—which is often. The string players are brilliant in sound but too close for ideal blending.

In other words, I don't think this is ideal Beethoven and Schubert projection, but I find it stimulating (musically) and new—and I suspect that it merely points the way towards our changing taste in the future of the recording art. Vanguard is surely doing the music no harm.

Oh yes—the performance: unlike most hi-fi demonstration records this one is musically first-rate. The Vienna State Opera Orchestra, also known as the Vienna Philharmonic, probably knows its Schubert and Beethoven as well as any orchestra, the music being hometown stuff. Prohaska merely conducts, which is a fine idea; there are too many attempts to be dramatically different in recordings of these overplayed works. These players could do the music quite well enough without any conductor, most likely.

**Tchaikowsky: Romeo and Juliet; Symphony #6; Piano Concerto #1.** (Assorted artists.) **Vox VXL-1 (16 rpm)**

There just isn't room to list all the artistry on these whopping long 16-rpm records from Vox and in any case the performances are already available on standard LP. The inter-

(Continued on page 54)

\* 780 Greenwich St., New York 14, N.Y.

The **HIGHEST STANDARD**  
in **HIGH FIDELITY...**



# AUDIO FIDELITY

**\*TOTAL FREQUENCY RANGE RECORDINGS**

AUDIO FIDELITY Records brings you unsurpassed sound reproduction — with new positive microphone technique, emphasis on clarity, brilliance and quality of recording consistent with maximum definition and minimum distortion, realizing the ultimate in signal-to-noise ratio, plus engineering techniques to maintain maximum level and dynamic range. Pressed on pure virgin vinyl formulated to result in long-wear of the high frequency groove etching as well as long life of the recording.

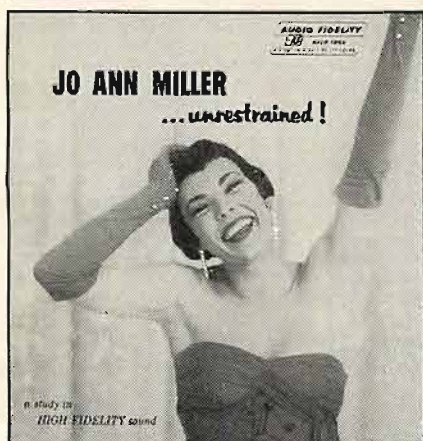

Brilliant new recording star! A pixieish gal with a voice that can "belt out" a song . . . be it the blues, a dreamy ballad or jazz. Witty arrangements plus a high-spirited performance add up to hours of delightful listening pleasure. AFLP 1864



Explosive, indefatigable "Hamp" — more vibrantly alive than ever before! Ingenious arrangements, eloquent improvisations, masterful performance . . . the unforgettable excitement of "Hamp" at his swingin' best! Unbelievable High Fidelity. AFLP 1849



Come to the Mardi Gras . . . Traditional happy New Orleans Mardi Gras Dixie by the Dukes of Dixieland! All the excitement of Festival time packed into a wild Dixieland album . . . and You Do Have To Hear It To Believe It! Volume 6. AFLP 1862

each 12 inch LP — \$5.95

**AUDIO FIDELITY INC.**

770 ELEVENTH AVENUE, NEW YORK 19, NEW YORK

WRITE FOR FREE CATALOG — Dept. FHF



# JAZZ and all that

CHARLES A. ROBERTSON\*

**Knocky Parker: Old Rags**  
**Audiophile AP49**

In as courtly and reliable a reading as is to be found on records, John W. "Knocky" Parker surveys a dozen landmarks of ragtime piano, from the early days of the cakewalk and breakdown to such linear descendants as Fats Waller's *Alligator Crawl* and *Bond Street*, a descriptive movement from the London Suite. His short history should do much to dispel the misconceptions and wrong interpretation, some perpetrated by supposedly informed critics and musicians, which have plagued this now vanishing art since its inception in the late 1890's.

One is the belief that ragtime is associated in the public mind with the sound of the player piano and can be most successfully recreated on an antiquated instrument, slightly out-of-tune. In one attempt to record this mechanical effect, tacks were inserted in the felt of the hammers. However, there is credence in the belief for the necessity of an action made flexible by long use. For this reason there were some doubts, before this session last June, whether Parker's technique would lend itself to the new Boesendorfer piano at Carroll College at Waukesha, Wisconsin.

His enthusiastic response to the instrument is related by Parker in the statement: "One of Joplin's rags is called *Euphonic Sounds* and he might have been talking about the Boesendorfer. Ragtime is supposed to be played with grace and beauty, and no other piano could quite as well bring out the Victorian filigree qualities (Sheraton, Hepplewhite furniture lines) and graceful proportions of these stately rags. *The Pearls* was so entitled by Jelly Roll Morton because of the pearl-like quality of the tones, and in one section the strings of the Boesendorfer vibrated like a violin. The piano is, I should think, the hardest of all instruments to record, and the Boesendorfer has a wider range of shading and dynamics that was a challenge to both of us."

For once it is not a question of the record equalling the sound of a live piano. Few homes, or concert halls for that matter, have instruments capable of matching the Boesendorfer as engineered by Ewing Nunn. In expressing his regard for it, he notes, "As far as I am concerned, the piano has a balance that I have never heard equalled. Its character of tone can be completely changed by the artist, from a soft singing type of tone to a relatively harsh metallic tone. I am aware of two or three makes of fine pianos produced in Europe and doubt if one of them deserves a place

very far ahead of the others. I do know that the Boesendorfer ranks among the topflight pianos in the world. It is a far better piano musically and structurally than will be found in this country. Only one hundred are made each year and each piano maker must, as always, spend an apprenticeship of ten years. The tone regulating is done between two matched Boesendorfers and it is said that none has been received in this country, after the trip from Vienna, that needed tuning."

Its manufacture has been a family institution since the firm was founded in 1828, when the patriarchal Ignatz built a ten-foot piano which could remain in tune throughout a concert by Liszt. It was also used by Brahms, and Hans von Bulow dedicated the firm's concert hall with a recital in 1872. Though an English action was added, is still known for its light, Viennese touch. That this should eminently fit it to Parker's technique could not have been foreseen by the founder, but ragtime owes almost as much to Liszt, by way of Gottschalk, as it does to the catchy rhythms of the dance and the banjo.

For ragtime leaned heavily on European forms and borrowed from folk tunes brought over from the old country, rather than spirituals and blues. In this lies a measure of both its strength and weakness. Like hop, another dialect of the language of jazz, it is limited in its approach. It drew increasingly from African rhythms for its syncopation and adapted blue tonality and harmonies, but as Marshal Stearns so rightly points out in his history of jazz, "it was never able to go the rest of the way and incorporate the bittersweet mood of the blues." So when the French writer Andre Hodier, in his opus, wonders why Stravinsky was reticent in using blue notes and effects in *Piano Rag Music*, and *Ragtime for Eleven Instruments*, it is probable that Stravinsky knew more about the subject in 1918 than Hodier does at this late date.

As ragtime is largely notated music and unremittingly cheerful, it lends itself to popularization by the Olman and Ardens, the Zez Confreys and almost anyone who can play piano. But it requires more than technique to play it correctly and only a handful of musicians from Scott Joplin to James P. Johnson have been able to give it the imprint of their personality. As an offshoot of the mainstream of jazz, it makes its most important contribution when embodied in the more inclusive style of a Fats Waller. Parker is content to meet the composer's intentions, remarking in a reference to Doc Evans, "We both try to play jazz the same way that classicists play, trying to show how Morton was an extension of Joplin, or George Mitchell a continua-

tion of Oliver. Form and analysis is in jazz just as much as in symphonic work, and great jazz composers had their own themes and styles and individuality just as definitely as Schubert and Ravel."

Back in 1937, while playing with the Light Crust Doughboys in Fort Worth, Parker demonstrated an ear which allowed him to copy Liszt from a record. This brought him to the attention of the Texas Christian music department, where he won a scholarship and his first piano lessons at the age of eighteen. Though he completed his studies by earning a Ph.D. in English, he never lost his affection for the jazz piano and an interest in its development. He brings to it a scholarship which places each piece in true historical perspective. He plays them at a moderate tempo to realize the full value of the original melodic figures.

A refreshing delicacy is given to *Georgia Camp Meeting* and *Whistlin' Rufus*. Included are James Scott's *Frog Legs* and *Climax*, Joplin's *Fig Leaf*, Morton's *Mr. Joe*, and Jimmy Johnson's *Daintiness*. Also Clarence Williams' *Wild Flower*, a tune as restful as a woodland glen. Making no bid by way of sensational impact, the recording, both for music and sound, is a thing of growing beauty.

**Ed McCurdy: Songs Of The Old West**  
**Elektra EKL112**  
**The Legend Of Robin Hood**  
**Riverside RLP12-810**

Taken in combination these two collections are solid proof that Ed McCurdy is a folk and ballad singer extraordinary. Each calls for a different interpretation of standard folk heroes, best portrayed by a virile, masculine voice. That he enters into the spirit of the cowboy and the England of Robin Hood, giving each the breath of authenticity, is performing of high skill and conviction. In his tour of the old West, he sings eleven songs, accompanied by Erik Darling on banjo, including *Sacramento*, *Buffalo Skinners*, *Jesse James*, *Brown-Eyed Lee*, and *The Cowboy's Dream*.

Early ballad sources are used by McCurdy and narrator Michael Kane to recreate the tale of the men of Sherwood Forest. A practiced storyteller, Kane sets the scene for each of the ballads, for which Frank Hamilton provides guitar accompaniment. In an engrossing visit of nearly an hour's duration to a land and era too often misrepresented in present day entertainment media. Though neither is designed specifically for the juvenile mind, I know from experience that children admire McCurdy's adult manner more than some efforts made for them. And so do members of an older generation. Both are admirably produced by Ken Goldstein.

**Banda Taurina: American Military Marches**  
**Audio Fidelity 1836**

Bandmaster Genaro Nunez leads his Banda Taurina, official ensemble of the Plaza Mexico in Mexico City, away from the bull ring in this album, to the tune of a dozen rousing military marches, and into the territory of the concert wind band. In his first recorded performance not associated with the arena, he shows a close concord with the work of John Philip Sousa on *Washington Post*, *El Capitan*, *King Cotton*, *Semper Fidelis*, and *Stars and Stripes Forever*. The shift from the color and drama of the fight to the stride of marching feet is a drastic one, but is accomplished in fine fashion by the band. The demand for a different sense of dynamics is answered in the same wide tonal range which made its previous efforts so popular.

Perhaps the most irresistible of the compositions also comes from below the border. It is Codina's spirited *March of the Zacatecas*, a piece spiced with the flavor of the fiesta. It is played with native skill, giving rise to the suggestion that this organization devote an album to Latin American marches. Also included are *Anchor Aweigh*, *Glory*,

\* 732 *The Parkway*, Mamaroneck, N. Y.



Unusually fine recording of the Flamenco guitar coupled with exciting, authentic Gypsy dancing. AFLP 1848

The joint's jumpin' on Bourbon St. . . . as the Dukes play slow, low-down gut struts and fast Dixie with a swing! Volume 4. AFLP 1860

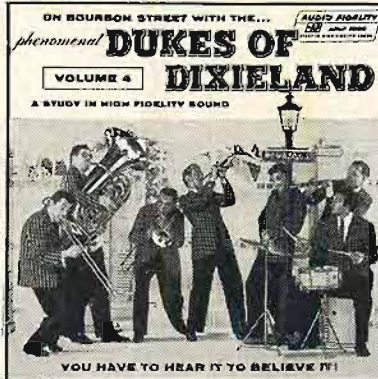

Rousing, frantic music from the Middle East. Mike Sarkissian and his Cafe Bagdad Ensemble. AFLP 1865

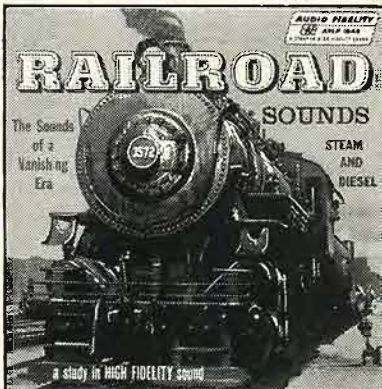

Steam engines . . . Diesel engines . . . earth-shaking dynamics of a vanishing era captured in high fidelity. AFLP 1843

Easy listening as Jack Anderson, at the Hammond Organ, opens a magic portal to a vast panorama of sound. AFLP 1856



records with excitement!!!

# AUDIO FIDELITY

TOTAL FREQUENCY RANGE RECORDINGS

For sheer exciting entertainment AUDIO FIDELITY produces the newest, up-to-the-minute, most delightful recorded creations. With the greatest sound engineering in High Fidelity . . . and the Fi is *fantastically* High!

each 12 inch LP — \$5.95

WRITE FOR FREE CATALOG — Dept. FH  
770 ELEVENTH AVENUE, NEW YORK 19, N. Y.



Wild, colorful, exciting, hand-clapping, heel-stamping authentic Spanish Gypsy music. Recorded in Spain. AFLP 1852



Leon Berry, plus the Giant in the basement and a fabulous technique add up to an exciting listening session of all-time favorites. Volume 3. AFLP 1844



Skirling Bag Pipes, rattling snares and booming bass drums! Well-known melodies, superb hi-fi! 9th Regiment Bag Pipe Band. AFLP 1857



Oscar Brand, vocals and guitar, Dave Sear on a real hot banjo, and a complete new album! Best Bawdy Songs yet! Volume 4. AFLP 1847

and *National Emblem*. There are three medleys titled *American Legion*, *Old Comrades*, and *Atlanta*, the last of which is a stirring recollection of the glories of Dixieland.

**The Modern Art Of Jazz, Vol. 3: Randy Weston**  
Dawn DLP1116

In this discursive exposition of his pianistic abilities Randy Weston touches up some popular tunes and improvises on three of his own bright themes. Handsome support on the trio numbers comes from drummer Willie Jones and Ahmed Abdul-Malik, whose bass engages in fertile exchanges with the piano. On the calypso *Run Joe*, *In a Little Spanish Town*, and an original blues, an able quintet is formed by the addition of Cecil Payne on baritone sax and Ray Copeland on trumpet, as Wilbert Hogan takes over on drums. Payne switches to alto on *You Needn't*, a characteristic piece by Thelonious Monk. Weston handles himself well in the assorted settings and is inventive on *Don't Blame Me* and *How High the Moon*. A capable composer, he should be ready to develop a more individual group sound for the trio. If it is to stand out from a dozen similar groups, it needs its own distinctive voice. Weston is creative in the accepted format and could easily turn some of his originality to the seeking of new forms, even though it means curbing some of his choruses. A fine recording by Dave Hancock.

**Dukes of Dixieland: On Bourbon Street**  
Audio Fidelity AFLP1860

The fourth volume by the Dukes finds them in a reminiscent mood as they recall the scene of their first professional engagement in New Orleans at the Famous Door. It was a formative period of nearly three years spent in developing their distinctive brand of dixieland, with its tight ensembles and assured solos. The tunes are the old favorites which any similar group might select to try their wings. There are the rags *Sensation* and *Climax*. And the blues *Dippermouth*, *Memphis*, *Wearry*, and *Royal Garden*. There is lifelike depiction in *New Orleans Funeral*, and their version of *Saints* expands it into a medley. The usual piano solo in *Ghimes Blues* is replaced by the real thing, and Frank Assunto plays a well-formed trumpet solo on *St. James Infirmary*. Clarinetist Harold Cooper has fine passages in low register, and trombonist Fred Assunto shows a spare up tempo style on *Indiana*.

Though still a youthful group, the Dukes have spent a decade together perfecting their ensemble work and giving it a mellow patina matched by few such organizations. As shown on *Riverboat Shuffle*, they are acquiring greater ease in contrapuntal sections. The new Electro-Voice wide-range Model 667 microphone with its transistorized remote-controlled variable response features is used in conjunction with Telefunken and RCA microphones. It aids in maintaining a balance and one result seems to be a crisp, natural drum sound.

**Mulligan Meets Monk**  
Riverside RLP12-247

Tangible evidence of some of the freshening winds blowing through jazz, and a heartening forerunner of things to come, are contained in this meeting of two of the leading representatives of two major schools of modern jazz. As Gerry Mulligan, a doyen of the cool Pacific Coast contingent, engages in a ruminative conversation with Thelonious Monk, an old settler in the land of hop, they consolidate their forces and, while stopping off to examine some odd corners, relate them to the mainstream of jazz. Like the recent joining of clarinetists Jimmy Giuffre and Pee Wee Russell on television during a Seven Lively Arts program, it is a significant encounter and can only lead to more such engrossing combinations and healthy realignments.

Though it was planned to expand the quartet with musicians of similar stature on formal arrangements, the mood created by Monk's piano and Mulligan's baritone sax proved too pristine for such intrusions. Ideas flow from Mulligan without limit, as though they had been held in check just for this moment, and

are most compassionate when he chooses to play below the solo piano. Comparable choruses are not recorded often, but there was Higginbotham behind King Oliver on *The Trumpet's Prayer*, or Young behind Billie Holiday. The four originals by Monk are *'Round Midnight*, *Rhythm-a-ting*, *I Mean You*, and *Straight, No Chaser*. Mulligan's *Decidedly* is a pulsing transformation of the Charlie Shavers' swing-favorite *Undecided*, with the standard *Sweet and Lovely* to round out the program.

With true economy, Monk makes a few notes do the work of an entire brass section, and bassist Wilbur Ware and drummer Shadow Wilson provide the tasteful, unobtrusive support appropriate to the occasion. The same high compliment can be given the engineering. It never distracts from the mood conveyed by the musicians.

**The Amazing Bud Powell, Vol. 3**  
Blue Note 1571

To say that this session finds Bud Powell back in the form which marked his first great solo sides on this label, after a hiatus of several years, should be recommendation enough to his followers. By presenting him in a trio with bassist Paul Chambers and drummer Art Taylor, and uniting him in a quartet with trombonist Curtis Fuller, it also recapitulates the concepts and innovations which made him the greatest influence on young pianists in the post-war years. His five originals are seasoned by many changes of mood and tempo to offer a rounded introduction to his style and technique.

Most important is *Bud on Bach*, described as "a piece called *Solfegetto* which I played when I was a child," which goes further than any words in contributing to an understanding of his intentions. Not distorting Bach's scope and form to the ends of jazz, he plays as Bach might had he listened to Powell. The opening passage is taken at an amazing clip to define its linear aspects clearly. When his accompanists join in, the lines are broken up and reformed by a vibrant and undeniable syncopation that is too seldom heard in modern jazz. Not only does he pay his respects to Bach, but to the countless jazz and ragtime pianists whose efforts he absorbed to make his accomplishments possible. It will play a significant part in any discussion of Powell and will be analyzed by critics for years to come.

*Frantic Fancies*, a fluent exposition of his single note melodic line, applies the same concept to a different form. *Some Soul* and *Keepin' In The Groove* are exercises on the blues in contrasting tempos, and *Blue Pearl* is a moody piece with a fine Chambers solo. Fuller, a rapidly maturing young Detroit, is added on *Idaho*, *Don't Blame Me*, and *Moose the Mooche* to allow Powell to show he still has his knack for feeding a horn. Like Thelonious Monk, another revolutionary figure on piano, Powell seems to have mellowed and his most satisfying work may lie ahead.

**Teo Macero With The Prestige Jazz Quartet**  
Prestige 7104

Though the debate on the validity of conservatory training for jazzmen is becoming academic as more and more young musicians seek such experience, Teo Macero is often cited as an example of one whose intensity of expression was not impaired by the school room. If anything, his stay at Juilliard made him a questing spirit in the whole field of modern music and he is likely to appear in the capacity of both composer and performer in classical and jazz works. In his search for new paths, he has kept clear of accepted formulas, except as a base for his wry humor and acid wit. Playing tenor sax with the newly-formed Prestige Jazz Quartet, he essays a modern concept of the ballad on five numbers written for the date, and Hal Overton's arrangement of *Star Eyes*.

Pianist Mal Waldron's *The Ghost Story* is an atmospheric piece and a contrast to his sprightly vibist Teddy Charles, and *Please Don't Go Now* is by John Ross. Macero's *Just Spring* has a quiet, pastoral setting and the charm of simplicity, a quality he should cultivate more often. For his studies gave him facility rather than inhibitions, and he likes

to explore subtle details before making his point. His ideas are far from routine and find sympathetic support from the quartet, surely the most modern of such groups. Jerry Segal is on drums and Addison Farmer plays bass.

**Howard Rumsey's Lighthouse All-Stars, Vol. 5**  
Contemporary C3517

In his latest installment from the Hermosa Beach Lighthouse, made by his 1954 and 1957 groups, Howard Rumsey puts the spotlight on a featured soloist in each number. The most recent session was held last March and finds trombonist Frank Rosolino on *Funny Frank*, tenor saxist Richie Kamuca on *That's Rich*, and trumpeter Conte Candoli on *If You Are There*. All are originals by pianist Dick Shreve. From the earlier date tenor saxist Bob Cooper is heard in his *Coop*, and pianist Claude Williamson plays his own *Claude*. Stu Williamson on trumpet, and Bob Enevoldsen, on valve trombone, combine on *S & B*, and Bud Shank plays alto sax on *Bud*. The hold-over members are Rumsey on bass in his specialty from Kenton days, *Concerto for Doghouse*, and drummer Stan Levey is a solo on *Stan*. Of course, the continuing influence is Rumsey who has for more than eight years provided a refuge for West Coast musicians and done much to keep their music from becoming frigid and ingrown. He is exuberant and swinging on both sides. Fine sound throughout, in spite of the time lapse.

**Clark Terry: Serenade To A Bus Seat**  
Riverside RLP12-237

Since the unquenchable Rubber Miley sparked his early band, Duke Ellington has usually managed to keep one exceptional trumpet player and at one time supported both Cootie Williams and Rex Stewart. None of them surpassed Miley in stature and it is not likely that any of the present section will do so, circumscribed as they are by the thoroughly-arranged character of today's band. Clark Terry, the most able of the current crop, was raised on the half-valve effects of Stewart, as opposed to the muted growl developed by Miley and used by Williams. But when he makes an infrequent appearance with a small group, as here, he has the same heady fire and creative drive which Miley used to pull his cohorts along beside him.

Thoroughly modern in concept, Terry is able in his five originals to negotiate things not thought of thirty years ago. He is technically assured in the title tune and its sequel *Cruising*. But in *Digits* and the blues called *Boardwalk*, he engages in a call-and-answer effect with Johnny Griffin, on tenor sax, to show an earthy quality which, like Miley's feeling for the blues, is pre-Ellington. Griffin was demanded by Terry for the session, and he proves his worth from Parker's swift *Donna Lee* to the standards *Stardust* and *That Old Black Magic*. The rhythm section consists of Wynton Kelly, Paul Chambers, and Philly Joe Jones. After this album, Clark Terry will not be sold short.

**The Playboy Jazz All Stars**  
Critics Choice Dawn DLP1123  
Jazz For Hi-Fi Lovers Dawn DLP1124

Gerry Mulligan is credited with the sensible idea of presenting the winners of the 1957 *Playboy* jazz poll on a separate number in the company of musicians who helped them gain their positions. Though the result is a two-disc sampler for a portion of the industry, it is a definite improvement on most all-star dates. With more than 20,000 ballots cast, the first in a series of annual polls cuts a vaster cross-section than previous competitions in the field and is as noteworthy for the juxtaposition of some of the runners-up as for the winners. Leonard Bernstein heads Dizzy Gillespie as a leader; Bud Shank places next to Sidney Bechet; John LaPorta is paired with Omer Simeon; and Ray McKinley with Kenny Clarke.

A tasty package includes photos and informative sketches of the winners, along with a complete tabulation of the voting. The oldest tape, a vintage Stan Kenton from 1940, is one of several tracks made on location and

(Continued on page 65)



*unquestioned masterpieces of precision!*



The precision marching of West Point Cadets never fails to quicken the pulse. Dedicated men with a common purpose... the group achievement transcending the sum of individual efforts... The precision achieved in JBL Signature Speakers is the result of such effort. Each skilled craftsman—be he machinist, designer, coil winder, engineer, or cabinet maker—is determined that preserving "JBL" as the symbol of the highest precision in loudspeakers shall be his individual responsibility. To you this precision means more accurate sound reproduction. More realistic sound reproduction. Cleaner sound reproduction. JBL precision brings you and the original performance closer together. You can readily identify JBL Signature units. JBL Extended Range Speakers have a large, silvery, dural dome in the center; and rigid, cast frames. JBL High Frequency Units may be equipped with the acoustical lens.

Or the unit that catches your eye may be the 075 with its gleaming, annular exponentially tapered horn. See and hear these paragons of precision in the demonstration room of the Authorized JBL Signature Audio Specialist in your community. For his name and address and a free copy of the new JBL catalog, write...

"JBL" means **JAMES B. LANSING SOUND, INC., 3249 casitas avenue, los angeles 39, california**





Eugene List makes his tape recordings on

**irish**  
BRAND  
ferro-sheen  
recording  
tape

That's not the reason why you should use

**irish**  
BRAND  
ferro-sheen  
recording  
tape

Here's why you should use

**irish**  
BRAND  
ferro-sheen  
recording  
tape:

It's the best-engineered tape in the world...

... gives you better highs... better lows... better sound all around! Saves your tape recorder, too—because the **irish FERRO-SHEEN** process results in smoother tape... tape that can't sand down your magnetic heads or shed oxide powder into your machine. Price? Same as ordinary tape!



Available wherever quality tape is sold.

ORRadio Industries, Inc., Opelika, Alabama  
Export: Morhan Exporting Corp., New York, N. Y.  
Canada: Atlas Radio Corp., Ltd., Toronto, Ontario

## AUDIO ETC

(from page 14)

How much of it is merely the expected early-model trouble, bugs to be ironed out, I don't know. (That treble tone control taper, for instance: nothing easier than to get hold of a control with the wrong taper by mistake.) In any case, I hastily point out that these faults, decidedly annoying and important for any home user, are mostly externals. The basic transistor amplifier is there and its is a work of enterprising and forward-looking design which I am heartily ready to praise. This company has been very much in transistor amplifiers—but this appears to be its first entrance into the hi-fi field, which is a far cry from missiles, aircraft instrumentation and the like where the company has done its main work.

All the more reason for some minor external revisions that would bring this really astonishing piece of equipment into line with standard hi-fi practice in the component field.

I should add, on the plus side, that the Vico has a few more features not yet mentioned. It takes advantage of transistor circuitry to provide a mike input that will take any old dynamic mike. (It must have been a last-minute addition; the specs don't mention it and the pictures don't show it.) No transformer needed for low-impedance mike, which is a welcome feature in many situations.

And since the basic operating voltage is 12 volts d.c., there is an optional power input on this amplifier for use with car batteries, etc., for portable operation. This is a marvelous idea—but, first, let me point out another potential fault here. I note that aside from a small plus and minus sign over the screw connections there is no positive way to be sure that the battery plus and minus polarity is right. Chances of a mistake (given most people's state of absent-mindedness) are high.

Now if I'm right, a good shot of 12 volts in reverse into this amplifier should pretty much ruin it in a few brief seconds. If not the transistors, then the coupling capacitors, which should be electrolytic. Therefore, for potential battery use I would like to see a clearly polarized socket of some sort, with *very* explicit instructions as to battery polarity and the dangers of reverse connection.

Be that as it may, I am enthusiastic about the future possibilities of the 12-volt basic system. This Vico model (with proper care as to connections) should prove to be a very fine camp and travelling hi-fi amplifier—perhaps unique in present possibilities—since the battery drain is so extremely low, the efficiency so high. Indeed, this would seem to me to open up new possibilities in portable hi-fi. I can envision a complete 20-watt hi-fi system, with space-saver type speaker, pouring out hi-fi music in some Maine fishing camp or maybe on the beach at Miami!

Quite seriously, this is an extraordinary new area for hi-fi expansion, if anybody is interested, and Vico clearly has the edge on all of us at the moment.

One more eccentricity in the Vico amplifier and I'll have 'em all off my chest. The TAPE output, for recording, is a non-standard pair of screw connections. Standard practice is now an RCA-type socket.

Don't let my criticisms keep you away

from this all-transistor machine. By the time my remarks are in print half of the faults will probably have been spotted and corrected, anyway. In which case the Vico 77 will be an amplifier that every enterprising gadgeteer will want to try—and a good many other people too.

## 2. GLASER STEERS

My reportings are almost always on a dual basis, as mentioned in the past: (a) how the gadget works when new and (b) how it stands up to long and strictly home-style use. I've only had the Glaser Steers GS77 changer for a few weeks and so I can report merely that so far is so good in respect to (b) above.

But I am already quite convinced that, as a new machine at least, this is a very nice changer—and I don't like changers. It is not only good looking but its performance is satisfactory and the vital functions of control are neat, easy-working and almost fool-proof, as well as quite standard in the expected ways. This is especially noteworthy in view of the fact that the GS 77 is a brand new model, not a revamped older changer, and so by the usual probability should be as full of bugs as... well, a bughouse. It isn't.

The GS 77, first, is neatly designed as to looks, if you like reasonably simple straightline geometry, with flight-style arrow-like shapes. Not too flossy, not at all obtrusive. Second, in actual operation this changer proved to be steady and low in rumble. How long the good performance will last I don't know. It is definitely there now.

The acid test for pitch steadiness came recently when I tried the new Vox 16 rpm records on the Glaser Steers, fully expecting the music to be unlistenable, for my supposedly acute musical ear, at least. To my surprise the 16-rpm music was as steady as anybody could expect. The only pitch-fault I heard was not due to the changer, an unpleasant slow wow on some sides due to off-center pressing. I was really amazed at this 16 rpm steadiness; I would not have thought it possible—even in a brand new machine—at this reasonable price level. Other changers can undoubtedly match it, but it definitely is OK in *this* one.

Low rumble and low external noise, plus steadiness, and all of this complicated by an ingenious idler-wheel withdrawing system that pulls the drive wheel away from the motor spindle during all changer operations. That could be the place for all sorts of minor trouble, but it isn't—so far.

The GS-77 arm is very light, very free, seems to track as well as many a professional arm at the equivalent point pressure of a few grams. Good performance here, too. My only complaint is that the stylus tends to skitter occasionally, often when it hits the slanted raised-edge lead-in grooves on most LP records. That's not an easy problem to solve.

So much for the basic performance. Very good—unusually good. The automatic parts, indeed, are both ingenious and trustworthy. This machine very seldom crosses you up and it doesn't ever act like a dizzy idiot, the way machinery does when things get beyond its limited intelligence! I

haven't been able to fool GS 77 yet nor has it outwitted me.

Four speeds, each separately settable, plus a setting called a "Speed-Minder" that really works. Chooses the right speed all the time—or darned near it. If you set the control to this position (at one end—you just flip it all the way in one direction), the machine does what others also do nowadays, chooses the right record size, for proper arm let-down, and also chooses the right speed, as between 45 and 33.

But this one goes a step further. If you have a proper small wire mounted on the pickup at one side, it will also distinguish between 78's and 33's at the 12-inch size. How? It doesn't choose the right point; it chooses the right speed for each point. Set the stylus on the 78 position and the machine turns at 78—so that if you put on an LP it plays too fast and you are safely warned. Similarly, if you have the LP-45 stylus in position and put on a 78, it will play at 33 and warn you.

The required small extended wire is soldered onto the GE pickup most often used; it can be added to some other dual cartridges without serious disturbance, as far as I can see. It operates into the arm-rest post, to select 33 or 78 speed, as the cartridge is rotated.

If you don't want the Speed-Minder, or have some non-standard record to play—a 16, for instance—you switch the knob from SPEED MINDER to the right speed, any one of the four, and there it stays, regardless.

This changer is, so far, unique in one interesting respect; the turntable stops dead for all changing cycles, allowing the record to drop directly, without that dismal skidding on the lower record or the table that is a distressing feature of most changers. This, too, sounds complicated and by every sort of common sense should cause all sorts of trouble in practice, but so far it hasn't. A side arm comes out and stops the table on a dime before the record drops (with some noise, to be sure—the change cycle itself is not exactly silent) the drive wheel has been duly retracted ahead of time. When the disc is down, the table starts again.

Another invaluable feature, not always found in other changers, is that the change mechanism operates at constant speed, regardless of turntable speed. This was a feature that should have come in with the LP record ten years ago; the Collaro from England was, I believe, the first to have it. The changer that has its cycle geared to turntable speed changes too slowly at 33 and too fast at 78; at 16 it crawls like a snail. The GS 77 changes efficiently at the same speed always.

One of my chief gripes with most changers is the lack of a true manual position, whereby you may play *any* band of an LP record without going through the whole annoying change cycle. Some changers won't play the inner bands at all unless you plough through the entire outer bands of the record first. The GS 77 is satisfactory in this respect. Send it through one change cycle, and you can then lift the arm onto the resting post, re-set it on any band. The trip mechanism is *very* polite; it doesn't go off until you jiggle the arm hard at the very inner groove position. (But it seems to work when it is supposed to.)

On this machine you may, if the telephone rings in the middle of a record, lift off the arm, set it on its rest, then replace it on the record part way through, all without setting off the cursed change mecha-

# KLH PRESENTS



## THE MODEL FOUR

A complete-range loudspeaker system of distinctly superior performance

The superiority of the KLH Model Four stems from an exhaustive effort to bring as close to perfection as possible every factor affecting loudspeaker performance.

- The KLH Model Four is a two-way loudspeaker system housed in a 13½H x 25W x 12"D cabinet. The low-frequency section is the same acoustic suspension mechanism used in the KLH Models Two and Three. Its very low distortion and smooth extended low-frequency response result in a quality of reproduction which is unique among loudspeaker systems.

- The high-frequency section uses a small diameter direct radiator designed to operate as a piston throughout most of its range. Its wide dispersion and exceptionally smooth extended frequency response immediately distinguish it as one of the very few available high-frequency reproducers which fill every part of the room with sound free from any harshness.

- Unequaled smoothness throughout the mid range is achieved by use of specially developed loudspeaker cones and by exceedingly careful attention to the design of a cross-over network which integrates the low- and high-frequency speakers into a complete-range system of such smoothness that the presence of two different speakers is undetectable.

A new standard of quality control in the manufacture of loudspeakers was introduced into the industry by KLH with the production of its Models One, Two, and Three. The same scrupulous care is applied to the production of the Model Four, thus assuring the uniformly high quality of every Model Four that leaves the KLH factory.

Although the development of the Model Four involved extensive engineering measurements, a truly fine loudspeaker system cannot be adequately described in terms of numbers, graphs, or other technical data. An appreciation of the magnificent performance of the Model Four can really be developed only by careful listening. When you do listen to the Model Four, you will notice that its superiority as an instrument for reproducing music becomes especially evident when it is compared, at the same volume level, with any other loudspeaker system.

At selected dealers. \$209.00 to \$231.00.  
Slightly higher in West and Far South.

RESEARCH AND DEVELOPMENT CORPORATION

30 CROSS STREET CAMBRIDGE 39, MASSACHUSETTS

DO YOU WANT

# Music?

...OR JUST SOUND

Full, wide-range, natural reproduction of all the musical notes—for enjoyable listening in your own home—comes first with Frazier. That is why Frazier-Engineered High Fidelity Speaker Systems prove so satisfying. It is not the size of the drivers, but the way they are coupled to an acoustically-adequate enclosure that gives you the range, the balance and the realism you want, with minimum distortion, without coloration, overdrive or hangover. Your listening is not complete until you hear the Frazier.



## HIGH FIDELITY *FRAZIER* NEW YORKER

Combines remarkable wide-range reproduction with beautiful cabinetry. Specially-designed inside this popular *New Yorker* is an amazingly compact folded exponential horn with a 20 cycle taper rate and a 202-inch long air column. Picks up bass notes as low as 20 cycles. Response is conservatively rated 30 to 17,000 cycles. Reproduces low notes from 16 foot organ pipes to highest overtones of flutes and tympani with life-like realism. Crosses over at 800 cycles, using 12 DB per octave. 48" x 26" x 16½". Mahogany, Ebony, Blonde Korina, or Walnut. Complete with speakers. Net, \$475  
Basic Utility Model F-202, less outer cabinet, \$375



## WIDE RANGE *FRAZIER* DIXIELANDER

This high fidelity wide-range loudspeaker uses a folded exponential horn in the woofer section, and an F-350 horn and driver for the tweeter section, with a constant resistance crossover at 800 cycles. Assures clean reproduction from 40 to 15,000 cycles. Gives life-like quality to speech, vocal, brass, strings and percussion. Available in Mahogany, Ebony, Blonde Korina and Walnut. 24¼" x 30" x 16½". With speakers. Net, \$250  
Basic Utility System, without outer cabinet, \$175



## FAMOUS *FRAZIER* HI-FI BLACK BOX

This popular F-8-3X gives you a direct radiator type tuned box, modified Hemholtz loudspeaker system for walls, closets, or any other location. Provides an 8-in. driver, high-pass filter, and cone-type tweeter, in a specially designed enclosure for pure, wide-range reproduction from 40 to 15,000 cycles. Size: 23½" x 19" x 11½". Complete with speakers. Net, \$57

Many Other Hi-Fi Models Available at Frazier Dealers to Meet Your Space and Budget Requirements

Send for Informative Bulletin No. F100-A

25 years in electro-acoustics  
*FRAZIER*   
International Electronics Corporation  
2649 BRENNER DRIVE, DALLAS 20, TEXAS

nism. Good! I get positively furious at changers that insist on changing to the next record when I haven't finished the one on the table. Like a hotel waiter who snatches away your roast beef when you're right in the middle of it.

I could go on and on . . . but this is enough. My general conclusion—so far—is that this GS 77 is a changer that has been well thought out, made remarkably fool-proof, and coordinated most intelligently with current practice in the field for standard-type operation.

I'm looking forward to a longer trial, to see whether it keeps it up.

### 3. GARRARD TPA-10

Garrard's new adjustable arm intrigued me so much that I decided to have a try at it under the usual extreme conditions of home Canby use. This is the arm that adjusts in length and tracking angle, to fit almost any situation. It is both a "twelve-inch" and a "sixteen-inch" arm at the same time.

Not bad. I tried it first in its longest position as a hi-fi arm with a big turntable and, after awhile, had it remounted inside a record changer box—which it fitted, rather to my surprise. Shorter length, sharper angle to the head. This second combination, by the way, made use of the recently-discussed Components Junior table; these two elements, the Components table and the Garrard arm, will fit together into the small space formerly occupied by a standard record changer which, I suspect, is something to remember. I doubt if there is any other possible manual-play combination of similar quality that will go into a piece of furniture that has been set up for changer use. (Perhaps the new B-J arm might fit, too; as I remember it is fairly short.)

The Garrard TPA-10 is styled in a way that will delight some and annoy others—I rather like it, myself. Cream-white base and rear assembly, telescoping squared tapering arm in chrome, black head. The pivot is an oddly shaped barrel affair, the arm crossing through at an angle to the vertical. It is a fairly big arm, depending on spring counterbalance for light point pressure.

More important to me is the fact that this arm is very comfortable in the using, with a rightly placed finger lift to one side of the head. After the new ultralightweight arms, so hard to move with the proper delicacy, this one is a pleasure to handle—and handle is the precise word. It's getting now so we really can't handle some arms without producing unintended squawks and serapes from the record. (No harm done—but the sound is highly objectionable even so.) The spring balance in this one somehow contributes to this ease of handling, though I really couldn't say just how. A certain feel to it, that gives you confidence and sureness in dealing with your records.

As to the adjustable feature, there's no doubt about its theoretical utility. As I say, the arm is good for full-length, no-restriction use where there is plenty of room, but can also be telescoped inward, the head bent further around, to fit in small spaces. It will adjust to any intermediate space, to give optimum length for each individual situation.

I can see a real need for this and am in favor of the basic premise. There are too many occasions in hi-fi buying where

measurements, even with detailed specs, do not make it clear whether a given arm, motor or what-have-you will fit in a given space. If your dealer does the installing for you, it's his risk; but if you buy your own for home installation, or buy by mail, you are likely to make painful mistakes in dimensionality in any such component as an arm, with the complex measurements it requires for an accurate account of its space needs.

(Yes, you get a template or diagram with the arm itself—but you can't get hold of this until the package is opened; it may then be too late.) Given a doubtful size situation, the Garrard can be depended upon to fit—anywhere within reason, and at the longest length that can be used.

In practice, I must add, there are some doubtful aspects of this adjustability. There is, first, a complex system for setting up the proper tangency for a given length which will have some people worried (unless they can get their dealers to take care of it). My installing assistant did considerable muttering to himself as he set up the arm the first time. But at the second installation (in the changer box) I heard definitely less and so I gather that he found it wasn't so complicated after all, on second try. Part of the trouble is surely in the instructions which seem a bit on the heavyweight side. (But please, nobody ask me to simplify them; there's nothing more difficult than writing instructions.)

A more parlous matter, I'd say, is the possibility for misadjustment. Give this arm's head a good push or knock (as some people will do, sooner or later) and the tangency slips off; the pivot pivots. It is supposedly set tight, after adjustment, but I knocked it loose, and quite accidentally. Carried the box in the back of my car and it must have slid against the side of the trunk with a jar. A violent misalignment is OK—the arm looks as though it had been broken. But a slight change in the pivot angle of the head could easily go unnoticed. I'd be happier if that adjustment were really solid and immovable except with a good deal of tinkering.

Also, note that to change the cartridge you must undo the arm's adjustable head and set your tangency all over again. Not too important.

As to the ride, the Garrard arm tracks reasonably well, is rather jumpy by the Canby Floorboard Test (see last month) but not too seriously jumpy in view of the violence of my particular floorboard action! A heavily viscous-damped arm might do better; but so would a room with respectably solid floors. Trouble isn't likely in normal use.

The spring pressure adjustment seems to me fairly hard to manage. The finer shades of point pressure are not too easy to achieve with the screw system used. You'll get it right with a bit more dickering than usual. It's easy down to six grams or so, rather delicate to adjust below that figure—if you want to go below. You won't want to, ordinarily. I have a feeling that the counterbalance spring contributes to the floorboard trouble; the arm is "springy" in the vertical plane. Again—it isn't important in any normal operation. You can't have everything.

Finally, I like the floating arm rest, a sort of pint-sized junior arm beneath the main one with a tiny upturned "hand" on the end which takes the main arm and holds it. Works well and its grip is good enough so that the arm isn't likely to bounce or joggle off the resting place.

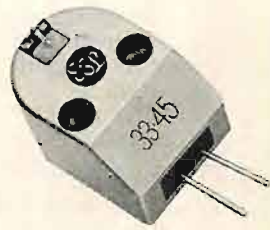

## NEW, EASY STEP TO perfection

Now, it's so simple for you to enjoy unprecedented perfection in record reproduction with the superlative new ESL C-60 Series electrodynamic cartridge.

You probably know that the ESL C-60 can reproduce all the sound on your records—tones and instruments you may never have heard before. You may know also that, unlike most leading pickups, the response of the ESL C-60 is inherently linear. This means your records will sound more natural, more musical, with the ESL C-60.

But do you realize how easy it is to enjoy this cartridge of tomorrow? There's no bother with input resistance, no interior alterations needed on your amplifier. No matter what the input resistor of your amplifier, the performance of the ESL C-60 is completely unaffected.

Transformers and transistor amplifiers are unnecessary, too, because the output voltage of the ESL C-60 Series is sufficient to drive all modern preamplifiers. There's no bother with special turntables or arms, either. The ESL C-60 Series performs brilliantly and ruggedly in any arm or record changer.

- ▶ Frequency response flat within 1 db 18 cps to 20,000 cps (Elektra 35 test record)
- ▶ Response extends beyond 30,000 cps
- ▶ Minimum output 10 mv at 10 cm/sec
- ▶ Minimum compliance  $6.8 \times 10^{-6}$  cm/dyne
- ▶ Dynamic mass 1 mg
- ▶ IM distortion almost immeasurably small
- ▶ Vertical stylus force 2-6 gms
- ▶ Output impedance 40 ohms at all audio frequencies

Best of all, this cartridge that's years ahead costs only \$39.50. Your high fidelity dealer has it now—make it yours today.

## unobtrusive

### MOVING COIL MICROPHONE

The new ESL-AT<sub>2</sub> omnidirectional, moving coil microphone is deservedly acclaimed throughout the world for television, broadcasting, recording, lectures, or vocal work where the microphone should be as unobtrusive as possible.

- ▶ Frequency response 50 to 10,000 cps  $\pm 3$  db
- ▶ Internal impedance 200 ohms
- ▶ Output level -55 db re 1 mw/10 dynes/cm<sup>2</sup>
- ▶ Probe length 18"
- ▶ Base diameter 2½"
- ▶ Net price only \$79.50 complete

Write for a free catalog of the entire line of new ESL moving coil microphones for every purpose at sensible prices.



FOR LISTENING AT ITS BEST  
Electro-Sonic Laboratories, Inc.  
Dept. A • 35-54 Thirty-sixth Street • Long Island City 6, N.Y.

the  
sum  
of  
all  
its  
parts...

silence



REK-O-KUT Rondine Turntable

REK-O-KUT HIGH-FIDELITY TURNTABLES—TURNTABLE ARMS  
38-19 108TH ST., CORONA 68, N. Y.

Custom-crafted motors feature wear-resistant bearings, electronically-balanced rotors.

Motor pulley machined with motor in operation—insures permanently smooth power transmission.

Special neoprene tire on idler wheel provides rumble-free traction and durability.

Motors and drives checked under operating conditions—insuring lifelong unerring performance.

Self-lubricating Spiral-Grooved turntable shaft, exclusive with Rek-O-Kut, provides oil-cushioned spin on chrome-steel ball bearing.

Cast aluminum turntable with resonant-inhibiting properties... machined to aircraft tolerances.

Prices from \$59.95

Write for  
Catalog and  
FREE STROBE DISC

## AMPLIFIER SPECIFICATIONS

(from page 25)

below rated output. That is, the noise is 90 db below the audio signal produced by delivering 100 watts to the speaker (which shall be assumed capable of handling this much power). Suppose that speaker efficiency is such as to require not more than 1 watt. But the listener hears just as much amplifier noise as ever. So the noise is actually only 70 db below the maximum audio signal emanating from the speaker. Thus one could say that the *effective* signal-to-noise ratio is 70 db.

To pursue this point a bit further, assume that two power amplifiers both specify a signal-to-noise ratio of 90 db, but that one has a rated output of 10 watts and the other of 50 watts. The effective signal to noise ratio of the smaller amplifier would be the higher. For equally low noise with the same speaker, the 50-watt unit should have a signal to noise ratio of 97 db (50 watts being 7 db more than 10 watts). If both amplifiers were rated with respect to 1-watt output, then the audio fan could immediately realize the difference in their noise performance. The 10-watt amplifier would be rated at 80 db and the 50 watt amplifier at 73 db.

With respect to sensitivity, the figure based on rated output is a very useful one. But it is also helpful to have the sensitivity based on a 1-watt output. Of course, given sensitivity for rated output, one can calculate the input voltage required for a 1-watt output. But this involves finding the square root of the ratio between 1 watt and rated output, and life would be easier for the audio fan if the calculation were performed for him. The new figure would enable him to compare driving requirements of different power amplifiers with respect to the sound level that he is realistically apt to encounter. Thus he might find that a control unit which has sufficiently low distortion only at output levels below 1 volt is quite adequate for his individual needs.

It is desirable to have the IM distortion percentage at a variety of output levels. While a chart is commendable because it presents a complete picture, unless it can be read with an accuracy of about 0.1 percentage point, it is desirable to have several key tabular values. Certainly one would want the IM figures at rated output and reference level output (1 watt). IM at 10 watts

and at 0.1 watt would add enough information to give a substantial picture of amplifier performance in regard to distortion.

Another approach might be to specify distortion at various percentages of the amplifier's rated output, as for example 100 per cent, 10 per cent, 1 per cent, and 0.1 per cent. This approach would imply that high-power units are intended for use with relatively inefficient speakers, while low-power units are intended for efficient ones.

#### Evaluation of the Power Amplifier

A low sensitivity figure (low input voltage required to drive the power amplifier to rated output) may be a disadvantage or an advantage. Assume that the sensitivity is 0.5 volt. This means that the noise from the control unit is amplified 6 db more than if the sensitivity were 1 volt. On the other hand, if the control unit has a sufficiently high signal-to-noise ratio so that a 6-db decrease in its ratio offers no problem, but it cannot put out more than 0.5 volt at satisfactorily low distortion, then the low sensitivity figure of the power amplifier becomes an advantage.

In evaluating the signal-to-noise ratio of the power amplifier, the efficiency of the speaker to be used is all-important. For example, a power amplifier may produce an amount of noise which is annoyingly perceptible with a highly efficient speaker, say 20 per cent. However, with a low efficiency speaker, say 1 per cent, amplifier noise would be reduced 13 db and probably become inaudible, or at least no longer annoying. (On the other hand, a top-quality power amplifier would not very likely produce an annoying amount of noise even with very efficient speakers.)

Similarly, evaluation of IM distortion depends a great deal upon speaker efficiency. A speaker with very low efficiency may require the power amplifier to operate at 10 watts or more a good deal of the time, while a high-efficiency unit may require 1 watt at the most. If the amplifier has very low IM distortion, say about 0.1 per cent, below 1 watt, but 2 per cent or more at 10 watts and over, it could be considered perfectly satisfactory for use with a high-efficiency speaker, though not with a low-efficiency model. For the latter case, one might wish an amplifier that produces at least 20 watts with no more than, say, 0.5 per cent IM. But such an amplifier, at least where distortion is concerned, could be considered a waste for a music system using no more than about 1 watt maximum; at such a level both amplifiers should sound equally clean. **Æ**



6A Stand Switch is an accessory and must be ordered separately

## THE NEW ALTEC LANSING "Acoustic Gate"\* MICROPHONE

#### SPECIFICATIONS

|                     |   |
|---------------------|---|
| Type:               | Dynamic   |
| Frequency Response: | 30—15,000 cps   |
| Output Impedance:   | Low, 30/50 ohms<br>Medium, 150/250 ohms<br>High, 20,000 ohms  |
| Output Level:       | —58 dbm/10 dynes/cm <sup>2</sup>                              |
| Dimensions:         | Diameter, 1" body, 1-1/2" ma-<br>Length, 7" (without connect) |
| Weight:             | 8 oz. (without connector)                                     |
| Finish:             | Black and green anodized                                      |
| Mounting:           | "Slidein" holder with 5/8"-27<br>Swivel head.                 |
| Price:              | \$96.00 net   |

**RUGGED! DEPENDABLE!** Years in development, the new Altec "Acoustic Gate"\* principle is available for the first time in the sensational Altec 680A microphone. This feature eliminates the high frequency peaks inherent in conventional dynamic microphones; and provides outstanding performance throughout an extended high frequency range. Here at last is a broadcast dynamic that can be used under any conditions. It is unaffected by wind, water, dirt or weather. The amazing Altec "Acoustic Gate"\* 680A is first for quality, ruggedness and serviceability.

\* "Acoustic Gate" is a peripheral sound entrance channel of 2 mil width which provides an acoustical resistance loading to the front of the diaphragm thereby eliminating high frequency peaks and extending the frequency response over an exceptionally wide range. (Patent Pending)



SOUND REPUTATION SECOND TO NONE

Write Dept. 2AJ  
1515 S. Manchester Ave., Anaheim, Calif. • 161 Sixth Ave., New York 13, N. Y.

## RECORD REVUE

(from page 42)

est, of course, is mainly in the 16-rpm sound itself and I must say I found it unexpectedly palatable.

First, on a good turntable the music is remarkably steady, even in that crucial test for flutter and fast wow, the piano. Note the Piano Concerto on this one. I had fully expected to find that my supposedly sensitive musical ear would be outraged by 16-rpm waver and flutter. No such thing.

On the other hand there was an unexpected trouble in respect to off-center pressing. For a variety of reasons this is far more crucial in 16-rpm than in LP. One reason is that the speed is too slow for your ear to take in the wow as a regular rhythm; instead, you are

aware of a vaguely seasick sinking . . . rising . . . sinking . . . that can be almost nauseating if the off-center component is serious. At least one of the sides I've tried has been of this sort.

My math isn't good enough to compute it, but I have a feeling that the slowed speed involves a greater pitch change per given off-center sideways than in the case of the 33. Somebody can check my ear on that. These 16's are no worse, decidedly, than the average run of LP pressings, but the off-center effect certainly is more noticeable, when & if. Something to watch out for.

The sound itself? On this first 16-rpm disc from Vox it is handsomely balanced and in the

main highly satisfactory, with an apparent range and clarity, right to the inner grooves, that I had hardly expected. (A few bad places in louder transients.) But strangely, the succeeding Vox releases have been of a dull-toned sort, as though severely cut off in the highs. The all-Tchaikowsky disc makes good listening on anybody's hi-fi system; but some of the later numbers—there are a half dozen or so already—are strangely muffled and out of balance on wide-range equipment.

I'm not sure I can account for the difference in my own mind. Balance is surely the key. The Tchaikowsky no doubt has a brilliant middle-high range that makes up for any lack of highest highs and keeps the music bright and clear. The other records, perhaps, may merely lack this "presence range" boost and so seem duller, though the tonal expanse is not very different.

Or—I'm thinking—it's always possible that somebody said to heck with it (distortion problems here and there)—and threw in a blanket cut-off at four or five thousand cycles per second. That would do it, neatly remove the distortion in the loud parts and ruin the over-all tonal balance as well. The baby with the bath.

We've had a lot of this sort of treatment in reissues of old 78's, and I deplore it. Better a bit of loud-passage distortion, here and there, than a total muffling of the very life of the recorded sound. Don't let's be too zealous in our cut-offs.

(Note: even the dull 16's will sound OK on small "hi-fi" phonographs with weak bass.)

### QUICKIES

**Pour La Harpe, Marcel Grandjany**  
Capitol P8401

Grandjany is the most musical, magical harpist I've ever known, which means that this record is terrific. The stuff he turns out is mildly classical, but marvellously digestible; a lot of it is harp arrangement of piano pieces by Ravel, Debussy, and other French composers (also harpsichord)—and it will melt in your ears. M. Grandjany makes the harp come alive; that's the only phrase that I can think up. If you want real music, not just a lot of pretty glissandos and harpy effects, try this.

**United States Air Force—a Portrait in Sound, Arthur Godfrey, narrator. Ward Botsford, producer.**  
Vox PL 10.520.

Jet planes blasting the sound barrier, missiles taking off after count-down (and *not* fizzling), pilots muttering jargon into grossly overloaded audio intercoms (*why* do they always do that??)—this is the ultimate. But it also, in case you're a jaundiced doubter, is a really fine job of dramatic presentation, within its own intentions; I enjoyed it and I admired it too. Don't forget that Godfrey is a life-long flying enthusiast himself, whose worst faults were a few minor errors having to do with an alleged control tower—he clearly is devoted heart and soul to flight and to our government's flying personnel; his narration is wholly sincere and without a trace of smugness or affectation. The man is good and knows how to talk—when he wants to.

The production was a real problem in recording and in organization. After all, breaking the sound barrier on discs can't be one bit louder than VU zero; the effect must be largely done via drama—crickets, silence, suspense. It is so done. Complicated cross talk between control towers, pilots, briefing officers—and Godfrey—must have posed fabulous problems in editing, for something less than utter confusion! If the whole show, in the long run, seems a bit propagandistic, well, it is. You couldn't lard it on heavier. I didn't mind.

**Testing, Vol. 2. True Sound of Musical Tones. Popular Science Monthly**  
Urania URS 2

This is quite a devastating little test record, in ways it probably didn't intend to be. It bravely sets out to indicate in terms of pure music and nothing else what various types

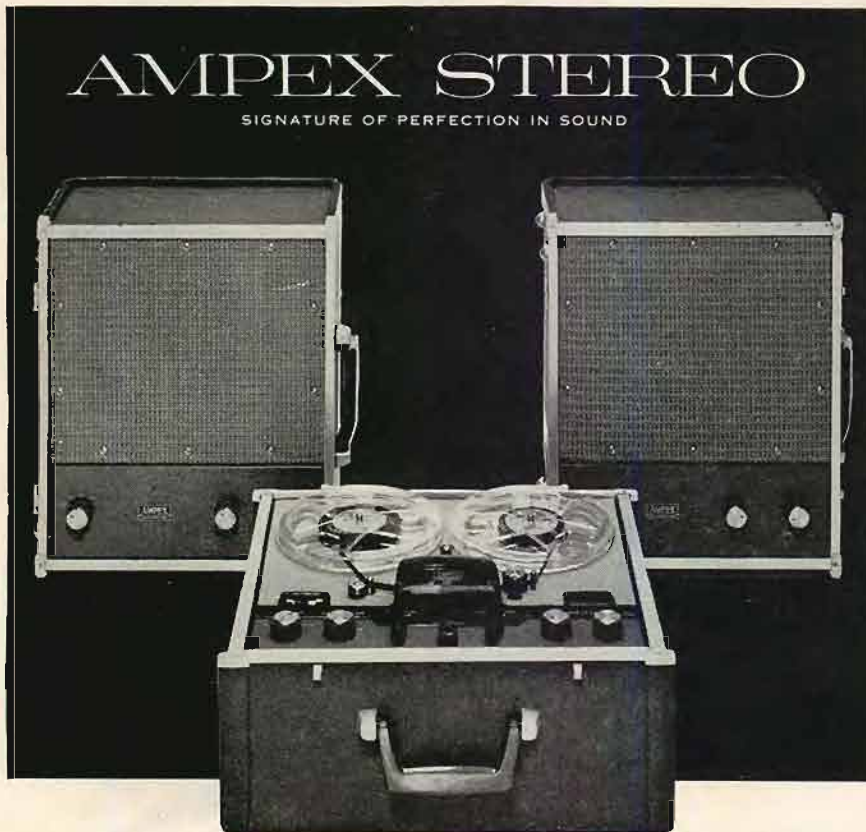

An audio system is like a chain. For optimum performance, all the links must be equally strong . . . there can be no compromise with "weak-link" components in the system.

It was on this premise that the Ampex A122-SP Portable Stereophonic System was designed. Each link in the chain—from recording and playback heads to speaker—was forged to the same exacting standards and precision tolerances which guide the manufacture of world-famous Ampex professional recording and playback equipment.

**Heads**—Facing surfaces of head gaps lapped to an optical flatness so precise they reflect a single light bond ( $1/2$  micron) on flatness gage. This, plus initial surface polish of 6-8 micro-inches, insures sustained frequency response with negligible change in characteristics over many thousands of hours of operation—many times longer than with ordinary heads.

**Amplifier-Speakers**—Ampex-designed, Ampex-built as an integral part of system . . . yet may be used separately with other units of your system (has front-panel input switching for Tape, Tuner, TV, or Phono). Amplifier sensitivity 0.25 v for maximum power output; 20-20,000 cps  $\pm 1/2$  db output with well under 1% harmonic distortion. Speaker features unusually high total gap energy, converts a maximum of output power into sound energy, with smooth, peak-free response.

**Complete Specifications**—Write today for free new full-color brochure containing complete specification sheet and description of full line of unmounted units, consoles, modular table-tops and portables.



#### AMPEX AUDIO, INC.

1036 KIFER ROAD,  
SUNNYVALE, CALIFORNIA

Please send free full-color folder:

NAME \_\_\_\_\_

ADDRESS \_\_\_\_\_

CITY \_\_\_\_\_

tonal range restriction and the like actually do to different musical sounds.

The instruments play—then play again, with a cutoff, and again with still another cutoff. Top and bottom. That's the technique and, being wholly objective (well, almost), it proves to you, the subjective listener, exactly what you want it to prove. Good.

It proved to me that music, that tough old language, can survive just about anything in the way of a rigorous recording climate. All the carefully deliberate scales, the "Twinkle, Twinkle, Little Stars," the solemnly played "Frere Jacques," sounded remarkably alike, cut-off or no cut-off.

Not *literally* the same. On a good system, the actual differences between full-range bass, a 65-cps cutoff and a 120-cps cutoff are clear enough to the ear. But musically they don't amount to a row of beans; you just hear the same old tones, piano, cello, double bass and so on—for the test really rubs it in, going right through a whole collection of different instruments. Very thorough.

The second side makes an interesting comparison between close-up musical instruments and the same instruments (playing the same music) as they sound out in the middle of a full orchestra. Not really a hi-fi test; more of a musical orchestration lesson, and a study in microphone technique. The orchestral examples aren't played by the same players as the close-up solos (they come from dubbed recordings) and so the playing isn't always the same, but the comparison is useful, even so.

Æ

## BOOK REVIEW

*Elements of Tape Recorder Circuits*, by Herman Burstein and Henry C. Pollak. New York: Gernsback Library, Inc., 1957. 224 pages. Paper, \$2.90; hard cover, \$5.00.

Depending on the interests of the reader, the books on the subject of tape recorders have already covered the field quite well except for the actual circuitry. The more technically inclined reader is quite likely to want information about circuits than about the many possible uses of the recorder or about the handling, storing, and editing of the final product, the tape itself.

In this book, the authors have covered the circuitry thoroughly, beginning with the basic elements and proceeding through the characteristics of amplifiers, recording and playback heads, and the tape. Bias requirements are outlined, and the need for equalization is pointed out, using fairly rigorous equivalent-circuit methods to show how the requirements for equalization are met in practice.

Oscillator circuits and level indicators are then described, and the authors conclude with a treatise on minimizing noise and hum in a tape recorder.

Anyone with the rudiments of circuit familiarity is certain to get a lot of useful information from this book, for it is the first we have seen which presents the tape recorder from the standpoint of a circuit designer. With the information contained here, the technician should have sufficient "tools" to enable him to change or correct equalization to improve performance or to bring an old machine up to date.

We feel that this is the most practical book of tape recorder information that we have seen to date, and we are pleased that these two authors have occasionally been among our list of contributors.

—C. G. McP.



# NEW FAIRCHILD single-speed 33 $\frac{1}{3}$ rpm TURNTABLE UNIT

easily converts to 4-speed electronic operation

The new Fairchild 33 $\frac{1}{3}$  rpm turntable is, by far, the finest single-speed unit ever designed. And it is priced at only \$99.50.

It is almost incredible. Rumble, wow and flutter have been so drastically reduced that if their presence is at all detected, they originate in the record or the recording equipment. It is the audio perfectionist's dream come true.

Utilizing the barest minimum of moving parts, this new turntable achieves an accuracy and constancy of speed, a quietness of operation beyond anything we have ever known. A hysteresis-synchronous motor drives a Densite-damped, aluminum turntable through a 2-stage belt drive.

The entire unit is mounted on a unitized chassis.

And by simply adding the Fairchild Electronic Control-Regulator, you can convert the single-speed unit into the fully electronic, 4-speed Fairchild E/D.



|  |          |
|--|----------|
| Turntable Unit, Single-Speed, 33 $\frac{1}{3}$ rpm.....          | \$ 99.50 |
| ECR (Electronic Control-Regulator).....                          | 135.00   |
| Fairchild E/D Electronic 4-Speed Turntable complete with ECR.... | 229.50   |
| Hardwood Base (shock-mounted) in walnut, mahogany or korina....  | 31.50    |

See your hi-fi dealer for complete details, or write:

**FAIRCHILD RECORDING EQUIPMENT CO.** 10-40 45th Ave., L.I.C. 1, N.Y.  
Export Department: 431 Fifth Ave., New York 1, N. Y.

Mister,  
You're Lucky...

For over thirty years Bakers have been making quality speakers for the discriminating British audiophile. These speakers are so outstandingly superior that they have long been known as "the best of the British speakers."

Mister,  
you're  
lucky . . .

for the new  
Bakers Ultra  
12, full-fre-  
quency range,  
12" speaker is  
now available  
in America for  
the first time.



A loudspeaker cannot be any better than what is put into it. The Bakers Ultra 12 is the best, not because of claims, but because design, parts, materials, and care in construction make it so. So look at the "specs." Frequency range . . . 20 to 25,000 cycles. Flux density . . . 18,000 gauss; 100,000 maxwells. High compliant, plastic foam, cone suspension. Non-resonant, cast, open, aluminum frame. Light, sensitive aluminum voice coil and former. Fully tropicalized. Hand assembled. Extra powerful Alcomax III encased in red cellulose. Dust, rust, and damp proofed. Exponential, bakelized apex, cone. Power . . . 20 watts plus. Voice coil impedance . . . 15 ohms. A full spread of 20 to 25,000 cycles without distortion crossover networks. Ingenious design and the use of new materials, processes, and techniques now make crossovers unnecessary. Acoustic impedance and efficiency mismatch; "disembodied highs;" and other undesirable characteristics of crossovers, are thus eliminated.

This combination of features, which cannot be found in any other speaker, makes the Bakers Ultra 12, unquestionably, the finest reproducer today. And the price . . . a mere \$85.00 . . . for the best.

If you want a speaker that is far superior to anything now available, insist on a dealer demonstration. You will be amazed at its smoothness, definition, cleanness, naturalness . . . a certain "something" that you have never heard before. Lucky owners say, "Mister, this is it." The "specs" tell you why.

Write for literature . . .  
and become sound happy.

**BRADFORD AUDIO CORP.**

Sole distributors for the United States  
27 East 38th Street  
New York City 16, N. Y. OX 7-0523

# ABOUT MUSIC

HAROLD LAWRENCE\*

## Baton and Stop Watch

**M**USIC FOR THE MOVIES has come a long way since the days of the silent film. Then, pit musicians were hired to mask the sound of the projection machine as well as crudely underline the action on the screen. Musical groups ranged from a solo upright piano to an ensemble of 50 musicians, depending on the size and location of the theatre. Publications of musical clichés covered the gamut of emotions and situations from love to hate, grief, custard pie, Indian dance, and bou-doir interlude.

The advent of the talking picture put an end to the career of the movie theatre musician, but not to background and cue music. Specialized recording companies still turn out hundreds of short pieces for radio, news reels, television and industrial films. One firm's catalogue accompanies each title with a descriptive blurb suggesting its possible use. Here are a few choice examples. *Ominous Interlude*: "uneasy music, building gradually, and increasing in tempo from the 28th second." *Sudden Embrace*: a 16-second romantic piece which "becomes eerie at the 7th second." *Centering Cats*: 26 seconds of humorous music, "with a light galloping rhythm, and a short ending for dialogue lead-in."

Skillful use of pre-fabricated background music in functional moving pictures can have fairly satisfactory results. But what may prove acceptable in an industry training film or a TV western is manifestly of little use in films of broader dramatic scope. Parenthetically many corporations who can afford it steer away from screen music libraries and commission their own scores.

The disappearance of "motion picture moods" from the Hollywood film was replaced by a new species of cliché. Two of the most familiar of these were "Mickey Mousing" and the technique of the *Leitmotiv*. The definition of "Mickey Mousing" is self-implied: music written to imitate action. When the hero lands a punch on the villain's jaw, the crack of knuckles against bone is aped by the orchestral sound track; the comedian slipping on a banana peel provides an excuse for a trombone slide; the derisive comment is accompanied by a wha-wha trumpet; etc. The *Leitmotiv* was a heavy-handed application of Wagnerian

technique in which thematic labels relentlessly dogged the footsteps of the main characters in the film, even to the absurd point of switching with each camera change.

A cliché of another kind was the wholesale adoption of certain composers' styles for stereotyped moods and situations. How many times has the Tchaikovsky *Romeo and Juliet Overture* reappeared in duel scenes; for how many screen lovers was Debussy's *La Mer* warmed over; and how many battles were waged to Strauss-like thunderings? In receiving an Academy Award not long ago for a film score he composed, Dimitri Tiomkin, with refreshing candor, accepted it not only for himself, but for his musical co-pilots, Tchaikovsky, Strauss, Rachmaninoff, and Ravel.

### Scoring Technique

With the numerous restrictions facing the film composer, it is little wonder that there is a shortage of good music on sound tracks. In fact, one look at the complicated process of scoring for the movies should be enough to frighten off all but the most intrepid souls, and even those who go into it have little hope of emerging musically unscathed.

First, the composer must meet with the director, producer and editor for a play-through of the film for which he is commissioned to write a score. There follows a discussion as to how much music is needed (requirements are measured in terms of reel feet, to be converted into seconds), where it is to be placed, and for how many musicians is it to be scored. Once these decisions are made, the composer works on preliminary sketches prior to his final, or "clocked" version. Then he closets himself with the Moviola, a projection machine which can be stopped at any point without setting fire to the film. In working on his musical score for "On The Waterfront," Leonard Bernstein saw the film some fifty times in sections or in toto on the Moviola. On the average, an hour-and-a-half film will require some 40 to 50 pieces of from 20 seconds to 3 minutes each, all of which must be perfectly synchronized to their related sequences.

Completed manuscripts are delivered to

\* 26 W. Ninth St., New York 11, N. Y.

the studio where they are checked by the music director with a stop-watch, and then assigned to a staff of copyists. When the entire score has been finished, a pre-session rehearsal is scheduled. This provides the composer with an opportunity to make last-minute alterations, the conductor with a chance to rehearse his players and familiarize himself with the work, and the engineer with time to adjust sonic balances. Throughout all of this, the director and producer chime in with suggestions of their own.

Finally, the actual recording session begins. The musicians are seated in normal concert arrangement, and the film is projected on a giant screen behind them. It is the conductor's job to keep an eye on the screen, another on his stop-watch, and a third on the score. He may therefore be excused if at times his tempi stray ever so slightly from the film, or his beat becomes uncertain due to the fact that he is overly engrossed in watching the screen, or he may miss giving a cue because he was so intent in retaining the precise tempo. Technical considerations apart, let us not forget that he also has to *interpret* the music at hand, especially if it is worth interpreting.

The director, on the other hand, is concerned with the over-all effect and may order eleventh-hour changes in the musical track. Ralph Vaughan Williams, who has made some fine contributions to the literature for films, describes such a state of affairs in an article on film composition: "Your music is illustrating Columbus' voyage and you have a somber tune symbolizing the weariness of the voyage, the depression of the crew and the doubts of Columbus. But the producer says, 'I want a little bit of sunshine music for that flash on the waves.' Now don't say, 'O well, the music does not provide for that; I must take it home and write something quite new.' If you are wise, you will send the orchestra away for five minutes, which will delight them. Then you look at the score to find out what instruments are unemployed—say, the harp and two muted trumpets—you write in your sunlight at the appropriate second; you recall the orchestra; you then play the altered version, while the producer marvels at your skill in composing what appears to him to be an entirely new piece of music in so short a time."

After the musicians have been dismissed, final takes are dubbed into the picture. The ultimate fate of the music is decided at the last editing sessions. This is where musical fragments are left on the cutting floor, whole sections are rendered inaudible, and phrases mutilated. In the face of this musical carnage, the poor composer is usually consoled with the thought that he can always arrange his mangled work in the form of a concert suite.

All in all, the film composer's lot is not a happy one. Why then do so many turn to this harrowing medium? The first and most obvious reason is money—but that is not the only reason. If he is willing to adapt himself to the arduous technique of film composition, the composer will find it an artistic challenge of the first water. **Æ**

**NEW!**

COMpletely VERSATILE AND DEPENDABLE...  
PROFESSIONAL PERFORMANCE

FOR YOUR HOME MUSIC SYSTEM

# THE FISHER 90-C

## Master Audio Control

**N**O TWO EARS hear music exactly alike. No two personal preferences in tonal balance are precisely the same, nor do the acoustical characteristics of any two surroundings duplicate each other exactly. The way the music sounds to *you*, in your normal listening environment, should be your most significant standard of performance. With THE FISHER MASTER AUDIO CONTROL, Model 90-C, you can achieve the tonal balance and color that suits *you* best. It will fully meet your personal, as well as the acoustic requirements, of the room in which it is used.

Among its many pace-setting electronic advances, THE FISHER Model 90-C includes a new PRESENCE CONTROL which brings solo instrument or vocal passages right out of the orchestral background. In addition, the 90-C offers a new, sharp-cut-off RUMBLE FILTER, to reduce low-frequency noise with no discernible loss of frequency response. With its facilities for mixing or fading from two to five channels, its Loudness Balance Control, its highly effective Bass and Treble Tone Controls, THE FISHER Model 90-C is by far the most versatile as well as the most comprehensive unit of its kind to be found anywhere! **Chassis, \$119.50**

Mahogany or Blonde Cabinet, \$9.95

WRITE TODAY FOR COMPLETE SPECIFICATIONS

FISHER RADIO CORP. • 21-29 44th DRIVE, L. I. CITY 1, N. Y.

*Superb Craftsmanship*  
*Magnificent Performance*

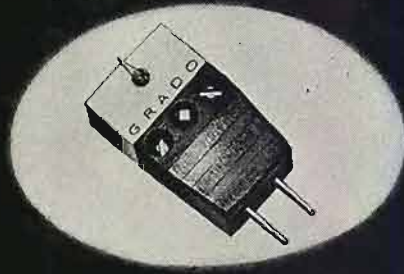

quality designed by **GRADO**

We announce with pride the development of a custom crafted phonograph cartridge of revolutionary design...*THE GRADO CONSTANT IMPEDANCE MOVING COIL TRANSDUCER.* This unit for the first time reproduces the peerless quality of the master tape. The Grado is precision made by master watchmakers to the highest electronic standards.

Used by leading audio manufacturers and research technicians as a laboratory standard.

Audiophile Net Price \$45.00

GRADO LABORATORIES • 4614 SEVENTH AVENUE • BROOKLYN 20, NEW YORK  
EXPORT DIV. • 25 WARREN ST. • NEW YORK 7, N. Y.

*New*

REVISED EDITION

**ELECTRONIC**

**MUSICAL**

**INSTRUMENTS**

By Richard H. Dorf  
(AUDIO Library — Vol. 1)

Up-to-date information about:

- SCHOBER
- CONN
- MINSHALL
- THOMAS
- KINSMAN
- ORGAN TUNING

**\$7.50**  
Postpaid

Customary discounts to dealers and distributors

If you missed the first edition, you're sure to want this new and revised second edition. And even if you have the first edition you are sure to want the latest information about the newest instruments. Order direct, Dept. E2, Radio Magazines, Inc., Mineola, N. Y.

## Los Angeles High Fidelity Show

### List of Exhibitors

**T**HE PLACE for every audiofan from February 26 to March 2 is the second floor of the Biltmore Hotel in Los Angeles, where the 1958 High Fidelity Show will be held. This is the second year that the institute of High Fidelity Manufacturers has held the show in Los Angeles, and the usual good turnout of visitors is expected. The list following gives the room numbers for the exhibitors at press time—undoubtedly there will be three or four more by the opening date. As will be observed, the entire high fidelity industry is well represented, and there are likely to be some highly interesting exhibits—what with the advent of the stereo disc.

Hope we'll see you there.

|   |            |
|---|------------|
| Acoustic Research                                 | 2112       |
| Altec Lansing                                     | 2338-2339  |
| American Electronics                              | 2303       |
| AMI   | 2316       |
| Ampex Audio, Inc.                                 | 2125-2126  |
| Audio Devices, Inc.                               | 2337       |
| Audio Fidelity Records                            | 2131       |
| AUDIO Magazine                                    | 2340       |
| Audlocom  | 2134       |
| Audlocrafters (Div. of<br>California Cabinet Co.) | 2216       |
| Audlogersh Corp.                                  | 2334       |
| Bel Canto Stereo Tape                             | 2128-2129  |
| Bell Sound Systems                                | 2205, 2207 |
| Bogen   | 2305-2306  |
| Bozak   | 2235       |
| British Industries Corp.                          | 2219, 2221 |
| Calbest Electronics                               | 2368       |
| Conrac  | 2217       |
| Dynaco, Inc.                                      | 2204       |
| Electro-Sonic Laboratories                        | 2359       |
| Electro-Voice                                     | 2352, 2354 |
| EICO  | 2346       |
| EMC Recordings                                    | 2115       |
| Ercona Corp.                                      | 2355       |
| Falchid   | 2236       |
| Ferrodynamics                                     | 2300       |
| Fisher  | 2223, 2225 |
| General Electric                                  | 2226       |
| Glaser-Steers                                     | 2308       |
| Golden Crest Records                              | 2311       |
| Grado Laboratories                                | 2361       |
| Gray Manufacturing Co.                            | 2357       |
| Harman-Kardon                                     | 2301-2302  |
| HIFI Records                                      | 2122-2123  |
| Hoffman Sales Corp.                               | 2106       |
| Holland Standard                                  | 2214       |
| International Electronics                         | 2341       |
| JansZen Loudspeakers                              | 2204       |
| Jensen  | 2335-2336  |
| Karlson   | 2324       |
| KLH Research and<br>Development                   | 2322-2323  |
| Klipsch & Associates                              | 2105       |
| James B. Lansing Sound                            | 2348, 2350 |
| McIntosh Laboratories                             | 2317-2318  |
| Majestic-International                            | 2109-2110  |
| Marantz Company                                   | 2208       |
| Mercury Records                                   | 2200       |
| Metzner Engineering Corp.                         | 2232       |
| Minnesota Mining & Mfg. Co.                       | 2319       |
| Mohawk Tape Recorders                             | 2127       |

wholesalers whose customers compete with such retailer."

This, the producer protested, prevented sales to retailers at prices less than those charged wholesalers whose customers competed with the retailer.

"The Act," said the court of this contention, "specially authorizes the Federal Trade Commission to bar discriminatory prices which tend to lessen or injure competition with 'any person who either grants or knowingly receives the benefit of such discrimination, or with customers of either of them.'"

Resting its decision on the authority of this statement of the law the court said in its denial of the application for a dismissal of the charges of discrimination against the International Telephone and Telegraph Corporation and the others, in the sale of C-F television and radio products, "There can be no doubt that a violation of this statute may occur when a manufacturer sells his products to a retailer at a lower price than that charged to a wholesaler whose customers compete with the retailer.

"Certainly one of the well known purposes of the Robinson-Patman amendment to the Clayton Act was to protect independent wholesalers from discriminatory concessions given by manufacturers to retailers whose size and volume of sales lead to a by-passing of the wholesaling function." Æ

## AUDIOCLINIC

(from page 4)

speaker, primarily by raising its resonance. How about drilling one or two small holes in the side of the cabinet to relieve this pressure? At the same time, so little of the back wave would escape as to be negligible. Richard J. Galvin, Chicago, Ill.

A. When a speaker whose suspension is flexible is used in conjunction with an infinite baffle, the speaker is in need of external damping. The pressure built up within the cabinet is a pneumatic spring which performs this damping function. Our own experiments have demonstrated that a speaker having a flexible suspension is the type which works best in such an enclosure, rather than one whose suspension is not very compliant. When the pressure is too low, the speaker will, among other things, tend to bottom more easily, possibly damaging it. Of course, if the pressure is too great the speaker will be over-damped and, therefore, impede the motion of the cone, especially at low frequencies, for it is on low frequencies that the cone travel is greatest. The easiest and most effective way to lower pressure is simply to increase the volume of the cabinet. If the box is large enough, no holes are needed to relieve pressure. If the box is too small, relieving the pressure will probably do little to improve performance, because the cabinet's physical size will not be sufficient to prevent front and rear wave cancellation. Æ

Excerpts from PRESS COMMENT on the

# AR-2

## High Fidelity (Tested in the Home)

"... With the (tweeter) control set to suit my taste (best described as row-M-oriented), oscillator tests indicated that bass was smooth and very clean to below 40 cycles, was audibly enfeeblished but still there at 35, and dropped out somewhere around 30 cycles. No doubling was audible at any frequency.

From 1,000 to 4,000 cycles there was a slight, broad dip in the response (averaging perhaps 2 db down), a gradual rise to original level at 8,000 cycles, and some minor discontinuities from there out to 12,000 cycles. Then there was a slow droop to 14,000 cycles, with rapid cutoff above that.

Because of its slightly depressed 'presence' range, the AR-2 has what is to me a refreshingly sweet, smooth, and highly listenable sound. Music is reproduced transparently, and with very good detail. Its high end is unobtrusive, but its ability to reproduce the guttiness of string tone and the tearing transients of a trumpet indicate that it is, indeed, contributing highs when needed. This, I feel, is as it should be.

Its low end is remarkably clean and, like the AR-1, prompts disbelief that such deep bass could emanate from such a small box.

"... Like the AR-1, the AR-2 should be judged purely on its sonic merits... not on the theoretical basis of its 'restrictive' cabinet size. When so judged, it can stand comparison with many speakers of considerably greater dimension and price.—J.G.H."

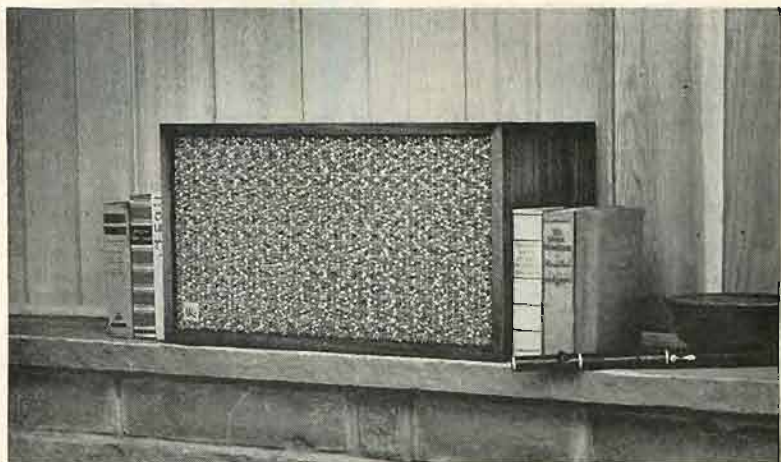

## AUDIO ETC.

of Acoustic Research Company

"... I find the AR-2 remarkably like the AR-1 in over-all sound coloration. Its cone tweeter is not the same, but there isn't much difference in sound. (It costs less, but that doesn't prove much.) On direct comparison, given a signal with plenty of bass component in the very bottom, you can tell the difference between the two in bass response. Most of the time, in ordinary listening, I am not aware of it at all.

"... I find AR-2, as with AR-1, remarkably clean and unobtrusive in its sound, easy on the ears for long-period listening, easy also to ignore in favor of the music itself. Either speaker has a way of simply fading into the surroundings (the size helps) leaving the music unattached and disembodied in the room. Excellent illusion!..."

Prices for Acoustic Research speaker systems, complete with cabinets, (AR-1 and AR-2) are \$89.00 to \$194.00. Size is "bookshelf." Literature is available from your local sound equipment dealer, or on request from:

**ACOUSTIC RESEARCH, INC.** 24 Thorndike St., Cambridge 41, Mass.

# NEW PRODUCTS

● **Shure Dynetic Tone Arm Assembly.** Although identical in performance with the original Model M16 tone arm and cartridge assembly, the new Model M12 is 3½ inches shorter to accommodate the trend toward more compact high-fidelity installations. The M-12 will handle records up to 12 inches in diameter whereas the M16 will play 16-inch transcriptions. Both the M12 and M16 use a 0.7-mil stylus for micro-groove records and operate at a stylus



force of one to two grams. The new M12 mounts on most turntables with exceptional ease. For convenience in mounting the M12 on Rek-O-Kut Rondine B12 Series turntables, a special adapter is available as an accessory. It utilizes the pre-drilled and tapped holes in the turntable base. Shure Brothers, Inc., 222 Hartrey Ave., Evanston, Ill. **B-1**

● **Transistorized Frequency Standard.** Stability under severe environmental conditions, compactness, and versatility combine to make the Transistron Model FS-195 Frequency Standard an extremely useful laboratory and production test instrument. Completely transistorized and powered by



self-contained batteries, it provides crystal-controlled standard frequency outputs for rapid calibration of oscilloscope sweeps and signal generators. Careful control of harmonic content allows a continuous spectrum well beyond 200 mc at usable levels. Successive use of 1-mc, 100-kc and 10-kc markers allows identification of calibration points as closely grouped as 10 kc. Extremely portable, the FS-195 weighs only 17 ounces and measures 6¾" x 4" x 2¾" in size. For detailed information write Transistron, Inc., Division of Van Norman Industries, 186 Granite St., Manchester, N. H. **B-2**

● **Stephens Speaker Enclosures.** Engineered to house the company's recently-introduced line of free-cone-suspension speakers, the new "Bass-Plane" enclosures operate on individualized principles of acoustic engineering. According to Ste-



phens engineers, the Bass-Plane enclosures achieve the smooth loading characteristics of an exponential horn in a compact cabinet of bass-reflex dimensions. The combination of high reactive duct venting and high resistance diffraction plates discharges the back wave along a flat wall or in a corner. The wall acts as a support plane for propagation of the bass wave, from which the term "Bass-Plane" is derived. Stephens Trusonic Inc., 8538 Warner Drive, Culver City, Calif. **B-3**

● **Sherwood 36-Watt Amplifier.** Newest addition to the Sherwood line of high-fidelity tuners and amplifiers is the Model S-1009 II, a 36-watt amplifier which is entirely exceptional in the flexibility and accessibility of its controls. Front-panel



controls include a 6-db presence-rise switch, equalizer control for four record compensation choices or microphone and tape-playback equalization, inverse-feedback-type bass and treble controls, loudness control, loudness compensation switch, 12-db/octave scratch and rumble filters, phono level control, tape monitor switch, and selector for five inputs. Output tube balance control permits adjustment without meters. Frequency response of the S-1009 II at 36 watts is 20 to 20,000 cps ± 1.5 db. Preamp sensitivity is 2.5 mv. Intermodulation is 1.5 per cent at full output. Sherwood Electronic Laboratories, Inc., 2802 W. Cullom Ave., Chicago 18, Ill. **B-4**

● **Shielded Zippertubing.** Great interest from the audio industry is certain to be accorded this laminated type of flexible



tubing with a zipper-type fastener to provide a shielded casing for multi-conductor wiring or cables. The new material is a plastic-saturated Fibreglass backing laminated to aluminum, lead, or magnetic foil. The laminated metal foil provides a method of grounding r.f. or stray hum pickup at a cost considerably lower than that of most tin or copper shielding with outer jacket. A feature of the harness casing is the ease of field maintenance through use of the patented slide fastener. For complete details, write for catalog sheet to Zippertubing Company, 750 S. San Pedro, Los Angeles, Calif. **B-5**

● **Fisher Master Audio Control.** Replacing the well-known Model 80-C which has been recognized as a standard for a unit of its type, the new Model 90-C Audio Control



Center features eleven controls, including a new presence control and rumble filter. Lever-type equalization controls match all current recording characteristics. Mixing and fading facilities are provided on two, three, four, or five channels. A 4-position loudness contour control automatically compensates for low-level hearing deficiency. Separate bass and treble controls are of the variable crossover type. Completely self-powered, the 90-C features a magnetically shielded and potted transformer. Standard NARTB equalization and sufficient gain are provided for playback directly from tape recorder heads. Added flexibility is afforded by seven inputs. Pushbutton channel selectors are equipped with indicator lights. Frequency response extends beyond the audio spectrum in both directions, and intermodulation and harmonic distortion are virtually non-measurable. Fisher Radio Corporation, 21-21 44th Drive, Long Island City 1, N. Y. **B-6**

● **Tape Splicer.** A unique low-cost tape splicer which uses a curved blade to make a splice with the "Gibson Girl" shape is the latest audio product to be introduced by Robins Industries Corp., Bayside 61, N. Y. Designated Model H-4, the unit consists of a tape-alignment guide and a special curved blade similar in appearance to

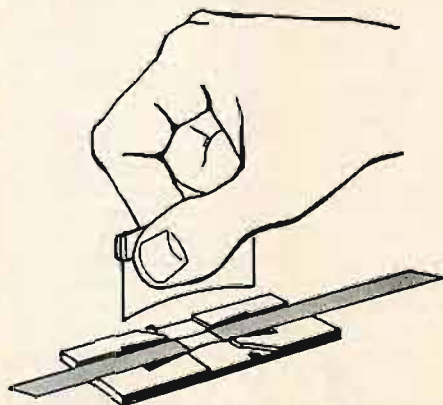

a single-edge razor blade, which affords a splice with a narrow indented waist. The tape guide is coated with pressure-sensitive adhesive for mounting directly on a tape recorder. **B-7**

OVER 17,000 HI-FI CUSTOMERS IN 1957  
BOUGHT **REALISTIC®** EQUIPMENT BY MAIL\*

\*BECAUSE **REALISTIC®** PRICES ARE LOWER, OFTEN BY 50% OR MORE!  
\*BECAUSE **REALISTIC®** QUALITY IS THE TALK OF THE HI-FI WORLD!

### REALISTIC® 12"-16" Arms

- ★ Silicon Oil **VISCOUS Damped!**
- ★ Exclusive **PLUG-IN Heads** (2)
- ★ Licensed under **CBS Patent** Number 2676806



- ★ 4 Separate Balance Weights for Latest Model Pickups!

16" ARM: Value \$39.95\* Sale **\$19.50**

12" ARM: Value \$29.95\* Sale **\$14.95**

\*Suggested Audiophile Net

### REALISTIC® Hysteresis Mk VII Turntable

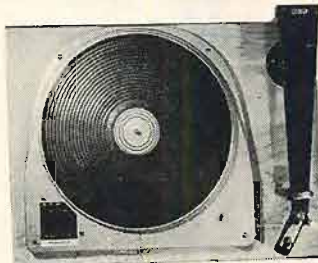

- ★ Hysteresis-Synchronous Motor!
- ★ Made to sell for \$84.50
- ★ 3 Speeds: 33 1/3, 45, 78
- ★ Meets NAB Broadcast Specs!

\$6 Down, **\$64<sup>50</sup>**  
\$5.60 Monthly

System below: \$9 Down, \$8.50 Monthly

COMPLETE SYSTEM: includes turntable, 16" viscous-damped arm, unfinished rock-maple base pre-cut for table, and new G-E **97<sup>50</sup>** VRII diamond-sapphire cartridge. Reg. value \$122.95.

### REALISTIC® 10W Amplifier



5 Tubes, Big Transformers!

BUILT TO SELL FOR \$44.95, this 10-watt amplifier is the best-selling basic control center in hi-fi today. 18 watts peak, 20-20,000 cps ±1 db @ 3W, built-in RIAA-equalized preamp section, bass and treble controls, 4-8-16 ohm taps, jack for direct feed to recorder, ship wt. 10 lbs. No frills or gadgets, just clean sound. *Low introductory sale price.*

**\$29<sup>95</sup>**

### REALISTIC® FM Tuner: Entirely New for 1958

Professionally wired and aligned, yet at or below "kit price"



- ★ 3 Microvolt Sensitivity **GUARANTEED!**
- ★ Tuned RF Stage! Automatic Frequency Control
- ★ Complete with Gold-Tone Metal Cabinet!
- ★ Built to Sell for \$69.95, you Save \$22.45

NEW MODEL of the FM tuner that received rave reviews in top audio magazine and reports! Attach to any amplifier, console or TV set. Compact 9 5/8 x 4 3/8 x 6 1/8" size. 20-20,000 cps response, Armstrong-type FM

Introductory Sale!  
\$5 Down, **\$47<sup>50</sup>**  
\$5 Monthly

### REALISTIC® Speakers



**\$19<sup>95</sup>**

2 FOR STEREO

Sale, 2 for \$37.50

14 1/2 x 11 x 10 1/2" In Cabinet! Fabulous "Solo", a compact dual-cone speaker complete and installed in its solidly-built mirror-finished mahogany case! Finished on FOUR sides. Includes runner feet. Tuned, vented duct-type Helmholtz resonator. 50-14,000 cps, matches 4-8 ohms. Made to sell for \$37.50.

### REALISTIC® Tape is GSF\*

\*Guaranteed Splice Free



1200' Guaranteed Splice Free Tape

7" reel, plastic base, exclusive Magne-Gloss highly polished oxide coating. Regularly \$3.39.

**\$1<sup>79</sup>**

1800' Guaranteed Splice Free Tape

7" reel, as above except 50% MORE playing time due to 1 mil. thickness. Regularly \$4.98.

**\$2<sup>69</sup>**

### Mail Coupon NOW!

#### Radio Shack Corporation

167 Washington St., Boston 3, Mass.

Please send me:

| Description  | Net*    | Order No. | Ship. Wt.  |
|--|---------|-----------|------------|
| <input type="checkbox"/> Speaker                               | \$19.95 | R-9036    | 12 lbs.    |
| <input type="checkbox"/> Two "                                 | \$37.50 | R-9036-2  | 24 lbs.    |
| <input type="checkbox"/> 16" Arm                               | \$19.50 | R-6602    | 5 lbs.     |
| <input type="checkbox"/> 12" Arm                               | \$14.95 | R-8148    | 4 lbs.     |
| <input type="checkbox"/> Amplifier                             | \$29.95 | R33-303   | 10 lbs.    |
| <input type="checkbox"/> FM Tuner                              | \$47.50 | R36-888-2 | 10 lbs.    |
| <input type="checkbox"/> Turntable                             | \$64.50 | R-7903    | 16 lbs.    |
| <input type="checkbox"/> " System                              | \$97.50 | R-7903SYF | 30 lbs.    |
| <input type="checkbox"/> 1200' Tape                            | \$1.79  | R-0212    | 1 1/2 lbs. |
| <input type="checkbox"/> 1800' Tape                            | \$2.69  | R-8118    | 1 1/2 lbs. |
| <input type="checkbox"/> More data on:                         |         |           |            |
| <input type="checkbox"/> FREE 64-page Hi-Fi Buying Guide #59-R |         |           |            |

\*Introductory sales prices for limited time

My Name \_\_\_\_\_

Street \_\_\_\_\_

Town \_\_\_\_\_ Zone \_\_\_\_\_ State \_\_\_\_\_

## RADIO SHACK CORP.

★ Mail Orders: 167 WASHINGTON ST., BOSTON 3, MASS.  
Stores: BOSTON, and 230 CROWN ST., NEW HAVEN, CONN.

# DYNAKIT

## Preamplifier

An Outstanding Companion  
Kit to the World Famous  
Dynakit Amplifiers

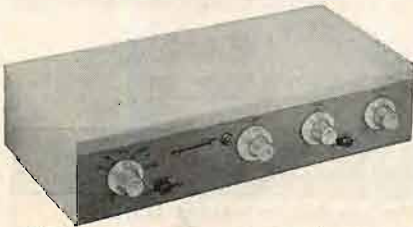

This handsome new control unit gives crystal clear, noise-free reproduction from any modern program source. Its unique all feedback design by David Hafner sets a new standard of preamplifier performance. The design of the Dynakit preamplifier is a synthesis of outstanding features which produce smoother, more natural sound. Compare these features with any other units regardless of price.

### ★ Unequaled performance

Actually less than .1% distortion under all normal operating conditions. Response  $\pm 5$  db 6 cps to over 60 kc. Distortion and response unaffected by settings of volume control. Superlative square wave performance, and complete damping on any pulse or transient test.

### ★ Easiest assembly

All critical parts supplied factory-mounted on XXXP printed circuit board. Eyed led construction prevents damage to printed wiring. This type of construction cuts wiring time by 50% and eliminates errors of assembly. Open simplified layout offers complete accessibility to all parts.

### ★ Lowest noise

Integral dc heater supply plus low noise components and circuitry bring noise to less than 3 microvolt equivalent noise input on RIAA phono position. This is better than 70 db below level of 10 millivolt magnetic cartridge.

### ★ Finest parts

1% components in equalization circuits to insure accurate compensation of recording characteristics. Long life electrolytic capacitors and other premium grade components for long trouble-free service.

### ★ High Flexibility

Six inputs with option of extra phono, tape head, or mike input. Four ac outlets. Controls include tape AB monitor switch, loudness with disabling switch, full range feedback tone controls. Takes power from Dynakit, Heathkit, or any amplifier with octal power socket.

### ★ Outstanding appearance

Choice of bone white or charcoal brown decorator colors to blend with any decor. Finished in indestructible vinyl coating with solid brass escutcheon.

### ★ Best Buy

Available from your Hi-Fi dealer at only \$34.95 net (slightly higher in the West), and yet the quality of performance and parts is unexcelled at any price.

Descriptive brochure available on request

Pat. Pending

**DYNACO INC.**

617 N. 41st St., Philadelphia, Pa.

Export Division: 25 Warren St., New York 7, N. Y.

● **Hi-Fi-Lite Speaker Baffle.** This novel item, manufactured by Lowell Manufacturing Company, 3030 Laclede Station Road, St. Louis 17, Mo., resembles a postillion lamp and provides both light and sound for outdoor entertaining. The Hi-Fi-Lite baffle is constructed of heavy-gauge spun aluminum, with the upper section



lined with jute for waterproofing. The lower section is a modified version of the Lowell STL baffle supported by four steel tubes, one of which is punched for concealment of speaker leads. The aluminum-topped glass lamp is between the support tubes. Although intended primarily for commercial use by country clubs, resorts, and drive-in restaurants, this novel development in "ear level" sound reinforcement is finding surprising favor among home owners, according to Lowell officials. **B-8**

● **Car Window Speaker Support.** Quickly enabling any car or truck to become a mobile sound vehicle, the new WM-1 car window speaker support, announced by

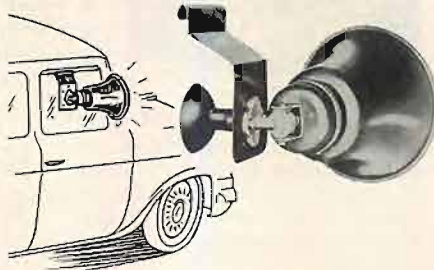

Atlas Sound Corp., 1451 39th St., Brooklyn 18, N. Y., safely attaches to any automotive window by means of a rubberized cork-lined channel. The channel slips over the window glass top and locks tightly when the window is raised. No tools are needed for the installation, which does no damage to the car's finish, window glass or window adjustment mechanism. **B-9**

● **Metzner "Starlight 80" Turntable.** Continuously variable speed control from 16 to 84 rpm is included among the features

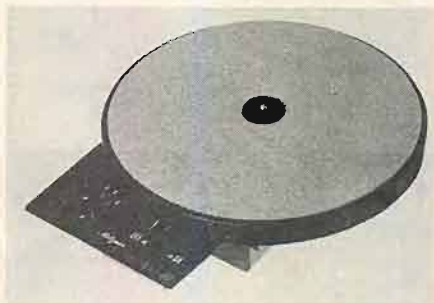

inherent in the new Starlight 80 turntable just announced by Metzner Engineering Corporation, 1041 North Sycamore Ave., Los Angeles, Calif. A built-in, illuminated stroboscope affords provision for exact adjustment at all four standard recording speeds. The machined turntable is center-driven. Wow and flutter are held to less than 0.25 per cent and rumble is 40 db below NARTB standard level. Remarkably low priced for a unit of excellent quality, the Starlight 80 is finished in coffee and gold and will enhance even the most tasteful surroundings. **B-10**

● **Atlas Super Tweeter.** Frequency response of 2000 to 17,500 cps, exceptionally low distortion, and a wide-angle distribution pattern are featured in the new Model HR-3 Super Tweeter recently announced by Atlas Sound Corporation, 1451 39th St.,



Brooklyn 18, N. Y. All parts comprising the acoustic path are constructed of precision die castings. Each diaphragm is checked for weight and compliance in order to assure functional uniformity. Impedance is 16 ohms and power handling capacity is 35 watts. Over-all dimensions are 7 1/4" w x 3" h x 6" d. Cabinet opening required is 6" x 2". **B-11**

● **"Music Minder" Shut-Off Switch.** With this device, music lovers who enjoy listening to records after retiring may do so without having to get out of bed to turn off the hi-fi system. The Music Minder shuts off the entire system after the last record has been played. A stack of records may be placed on the changer and the system left entirely unattended. Should the user not wish to use the automatic feature, a switch can be set on "manual," in which case the unit becomes inoperative. Marketed by CBC Electronics



Co., Inc., 2601 N. Howard St., Philadelphia 33, Pa. **B-12**

## JAZZ AND ALL THAT

(from page 46)

previously unissued. Lester Koenig of Contemporary is responsible for the expert handling of the difficult job of mastering a variety of material. He also arranged dates last July, featuring Shelly Manne and Barney Kessel, especially for the album.

As one whose interest in polls is virtually nonexistent, I can, however, recognize their importance to the performers and their value in introducing a new audience to jazz. If *Playboy* finds its efforts in this direction as rewarding a promotion stunt as a cover-girl photo, it might eventually perform a greater service by instituting a *Playboy, Jr.* competing for new stars.

Such a category could well result in an album as diverse and completely satisfying as the two samplers issued by Dawn. They combine the instinct of producer Chuck Darwin for discovering new talent, or finding a stimulating setting for established men, with the careful engineering of Dave Hancock. Though only Bob Brookmeyer is included with the *Playboy* winners, Oscar Pettiford, Zoot Sims, Al Cohn, and Tony Scott all placed high in the listings. Both discs rate equal commendation for music and sound, but the second has an informative liner note by Hancock on the mechanics of his profession.

### Johnny Griffin, Vol. 2 Blue Note 1559

Subtitled as a blowing session, the second album bearing the name of the Chicago tenor saxist Johnny Griffin is just that, in spite of the programming of two Jerome Kern ballads. *The Way You Look Tonight* is taken at a rapid tempo which slows only slightly for *All The Things You Are*, for Griffin is out to meet the challenge of John Coltrane and Hank Mobley, two other powerful performers on his instrument. All are uncompromising in their attack, and the supercharged atmosphere is mitigated only by the crystal-clear solos of pianist Wynton Kelly and bassist Paul Chambers. Lee Morgan, on trumpet, balls into the spirit of things and uses his surefire technique to show his brilliant, brassy side. Art Blakey confines his drumming to the main task of putting the tenormen through their paces. Though an accurate picture of their contrasting personalities emerges, it is all on the level and must be filled out elsewhere. The two originals by Griffin carry the descriptive titles of *Ball Bearing*, a well-oiled vehicle for plunging solos, and *Smoke Stack*, a darkly churning blues.

### Paul Quinichette: On The Sunny Side Prestige LP7103

After following in the footsteps of Lester Young for most of his career, and filling his chair in the Count Basie band, Paul Quinichette is making a determined effort to develop a more individual style on the tenor sax. To aid in the change, he has on this session the arrangements of pianist Mal Waldron and the presence of John Jenkins and Red Kyer, two adventurous young alto-sax men, and trombonist Curtis Fuller. As he shows on the title tune, Quinichette is dispensing with none of the knack of the veteran swing performer, but is engaged in broadening

his style and adding to it in depth. Always highly talented, he is gaining a more personal voice and realizing more of his great potential strength. Waldron's *Blue Dots* is a reflective piece, and his *Circles* is a rhythm tune for a round of solos. *Cool-Lypso* is some funmaking at the expense of the island beat, with Doug Watkins and Ed Thigpen setting the tempo.

### Bud Shank: Gary Crosby World Pacific P2006

On the basis of this album, Gary Crosby will be able to look back with affection at his stay in Frankfurt-am-Main as part of the American Forces Network. Free of commercial pressures and the necessity to sing rock and roll, he has developed an assurance and personality of his own to add to the Crosby sound. The once callow youth is now a mature performer and his full-fledged appearance on the scene is a pleasant surprise. As to style, he seems to have settled on a spot midway between his father and Jack Teagarden—a good spot on which to alight. His voice has taken on depth and the resemblance to Teagarden is accentuated by the choice of *I Got a Right to Sing the Blues*, *If I Could Be With You One Hour*, and *Love Is Just Around the Corner*.

Under the leadership of Bud Shank, the twelve-piece orchestra, consisting of Europeans, one other American and two Indonesians, plays arrangements by Bill Holman and Johnny Mandel. Shank on alto sax and flute shares solo honors with Hans Koller on tenor sax. Crosby fits in well with the suave West Coast sound, but it becomes evident that he is ready for any assignment as he sings *Skylark*, *Blue Prelude*, *One For My Baby*, and *Exactly Like You*. The AFN can be proud also of the engineering by Sgt. Jules Diamond.

### Maynard Ferguson: Boy With Lots of Brass EmArcy MG36114 Al Baretto: Whisper Not Capitol T901

Though one operates as a big band and the other as a sextet, these two units are unabashed crowd-pleasers yet strive to improve their standing as dispensers of jazz. Commercial pressures being what they are, Maynard Ferguson calls frequently on popular tunes and his sensational talent for blowing high trumpet notes. By way of compensation, he offers full-toned work in mid-register, is appealing on valve trombone, and employs arrangers Al Cohn, Ernie Wilkins, and Willie Maiden. Irene Kral sings *Imagination* and *The Song Is You*.

Al Baretto aims his alto sax at the night club audience, and ventures to follow entertaining group vocals on *Cross Your Heart* and *Sunday* with the challenge of Benny Golson's *Whisper Not*. The sextet has a fine group spirit and seems secure in the knowledge it can please on several levels, contrasting *Lover Man* with *What's New*. Both organizations realize their obligations to listeners of varied tastes, and the recordings are well-tailored to fit the big and the small.

## LOUDNESS, ITS DEFINITION

(from page 34)

These switches were provided at each position and were arranged so that the operations of one observer could not be seen by another. This was necessary to prevent the judgments of one observer from influencing those of another observer. First they heard the sound being tested, and immediately afterwards the reference tone, each for a period of one

second. After a pause of one second this sequence was repeated, and then they were required to estimate whether the reference tone was louder or softer than the other sound and indicate their opinions by operating the switches. The levels were then changed and the procedure repeated. The results of the tests were recorded outside the booth.

## DYNAKIT Amplifier Kits

A proven circuit of finest sound quality in a new deluxe 60 watt model and standard 50 watt model



**MARK III** 60 Watts **7995\***

4, 8, 16 ohm outputs

net

The new Mark III includes all the sensational attributes of the popular Mark II plus these outstanding deluxe features

- ★ 60 watts at less than 1% distortion. Instantaneous peak power of 140 watts. 1M less than .05 at average listening levels.
- ★ Choke filtering and low noise circuitry reduce hum and noise to 96 db below 60 watts.
- ★ New rugged KT-88 tubes and other heavy duty parts used conservatively.

**MARK II** 50 Watts **6975\***

8, 16 ohm outputs

net

The Mark II is the best buy in high power high fidelity kits

- ★ Ease of assembly due to uniquely simple circuitry and printed circuit construction with factory-mounted parts.
- ★ Highest stability using patented stabilizing networks with minimum number of phase shifting stages. Suitable for all loudspeaker systems including electrostatic.
- ★ Dyna Biaset (patent pending) for simplified adjustment and complete freedom from effects of unbalanced components. No balancing adjustments required to meet published specifications.
- ★ Dynaco Super-Fidelity output transformer with patented para-coupled windings. This is the finest available transformer of its type for the most critical audio uses.

\*Slightly higher in West

Available from leading Hi-Fi dealers everywhere  
Descriptive brochure available on request.

**DYNACO INC.**

617 N. 41st Street, Philadelphia, Pa.

Export Division: 25 Warren St., New York 7, N. Y.

# At Last! Tape-Indx

\*Patent Applied For

**THE PERFECT  
TAPE INDEXING SYSTEM**

- Simple
- Accurate
- Economical

Now—at last—you can index your recorded tape accurately—and as easily as you apply a postage stamp. Index as many as five reels with 6 tabs each for only \$1.00. Companion product to Tape Indx, "Perma-File" to identify your tabs and catalog your titles only \$1.00.

**Tape-Indx**  
DATREL COMPANY  
520 Fifth Ave., New York 36, N. Y.

The typical recording chart shown in Fig. 16 contains the results of three observers testing a 125-cps tone at three different levels. Two marks were used for recording the observer's judgments, a cipher indicating the 125-cps tone to be the louder, and a plus sign denoting the reference tone to be the louder of the two. No equal judgments were permitted. The figures at the head of each column give the voltage level of the reference tone impressed upon the receivers, that is, the number of decibels from 1 volt, plus if above and minus if below, and those at the side are similar values for the tone being tested. Successive tests were chosen at random from the twenty-seven possible combinations of levels shown, thus reducing the possibility of memory effects. The levels were selected so the observers listened to reference tones which were louder and softer than the tone being tested and the median of their judgments was taken as the point of equal loudness.

The data on this recording chart, combined with a similar number of observations by the rest of the crew, (a total of eleven observers) are shown in graphical form in Fig. 17. The arrow indicates the median level at which the 1000-cps reference, in the opinion of this group of observers, sounded equally loud to the 125-cps tone.

The testing method adopted was influenced by efforts to minimize fatigue effects, both mental and physical. Mental fatigue and probable changes in the attitude of an observer during the progress of a long series of tests were detected by keeping a record of the spread of each observer's results. As long as the spread was normal it was assumed that the fatigue, if present, was small. The tests were conducted on a time schedule which limited the observers to five minutes of continuous testing, during which time approximately fifteen observations were made. The maximum number of observations permitted in one day was 150.

To avoid fatiguing the ear the sounds to which the observers listened were of short duration and in the sequence illustrated on Fig. 18. The duration time of each sound had to be long enough to attain full loudness and yet not sufficiently long to fatigue the ear. The reference tone followed the  $x$  sound at a time interval short enough to permit a ready comparison, and yet not be subject to fatigue by prolonging the stimulation without an adequate rest period. At high levels it was found that a tone required nearly 0.3 second to reach full loudness and if sustained for longer periods than one second, there is danger of fatiguing the ear.<sup>13</sup>

To avoid the objectionable tran-

<sup>13</sup> G. v. Bekesy, "Theory of hearing," *Phys. Zeits.* 30, 115 (1929).

## AT LAST!

**The book you have waited  
for so long —**

**EDGAR M. VILLCHUR'S  
HANDBOOK OF  
SOUND REPRODUCTION**

For over two years, this material ran in consecutive issues of *AUDIO* and was followed avidly by every reader. Now available in book form, with corrections and minor revisions, this material will be recognized as the basis of a thorough course in sound reproduction. Covers the subject from the elements of sound to individual chapters on each of the important components of a sound reproducing system. Ready for immediate delivery, \$6.50 postpaid.

Customary discounts to dealers and distributors

---

**RADIO MAGAZINES, INC., Book Division**  
P. O. Box 629, Mineola, N. Y.

Please send me ..... copies of Villchur's **HANDBOOK OF SOUND REPRODUCTION** I enclose check  money order  for \$6.50 each.

Name .....

Address .....

City ..... Zone ..... State .....

TABLE XVI  
COMPARISON OF ONE AND TWO-EAR LOUDNESS BALANCES  
A. Reference tone voltage level = -32 db

| Frequency, c.p.s.          | 62   | 125 | 250  | 500  | 2000 | 4000 | 6000 | 8000 | 10,000 |
|----------------------------|------|-----|------|------|------|------|------|------|--------|
| Voltage level difference * | -0.5 | 0   | +1.0 | -1.0 | -0.5 | -0.5 | +0.5 | -3.0 | -3.0   |

B. Other reference tone levels

| 62 c.p.s.             |                          | 2000 c.p.s.           |                          |
|-----------------------|--------------------------|-----------------------|--------------------------|
| Ref. Tone Volt. Level | Volt. Level Difference * | Ref. Tone Volt. Level | Volt. Level Difference * |
| -20                   | +0.5                     | -3                    | 0.0                      |
| -34                   | +0.2                     | -22                   | +0.3                     |
| -57                   | +2.0                     | -41                   | -0.8                     |
| -68                   | -0.5                     | -60                   | -0.8                     |
|                       |                          | -79                   | -6.2                     |

\* Differences are in db, positive values indicating a higher voltage for the one ear balance.

sients which occur when sounds are interrupted suddenly at high levels, the controlling circuit was designed to start and stop the sounds gradually. Relays operating in the feedback circuits of the vacuum tube oscillators and in the grid circuits of amplifiers performed this operation. The period of growth and decay was approximately 0.1 second as shown on the typical oscillogram in Fig. 19. With these devices the transient effects were reduced and yet the sounds seemed to start and stop instantaneously unless attention was called to the effect. A motor-driven commutator operated the relays which started and stopped the sounds in proper sequence, and switched the receivers from the reference tone circuit to the sound under test.

The customary routine measurements to insure the proper voltage levels impressed upon the receivers were made with the measuring circuit shown schematically in Fig. 15. During the progress of the tests voltage measurements were made frequently and later correlated with measurements of the corresponding field sound pressures.

Threshold measurements were made before and after the loudness tests.

They were taken on the same circuit used for the loudness tests (Fig. 15) by turning off the 1000-cps oscillator and slowly attenuating the other tone below threshold and then raising the level until it again became audible. The observers signalled when they could no longer hear the tone and then again when it was just audible. The average of these two conditions was taken as the threshold.

An analysis of the harmonics generated by the receivers and other apparatus was made to be sure of the purity of the tones reaching the ear. The receivers were of the electrodynamic type and were found to produce overtones of the order of 50 decibels below the fundamental. At the very high levels, distortion from the filters was greater than from the receivers, but in all cases the loudness level of any overtone was 20 decibels or more below that of the fundamental. Experience with complex tones has shown that under these conditions the contribution of the overtones to the total loudness is insignificant.

The method of measuring loudness level which is described here has been used on a large variety of sounds and found to give satisfactory results.

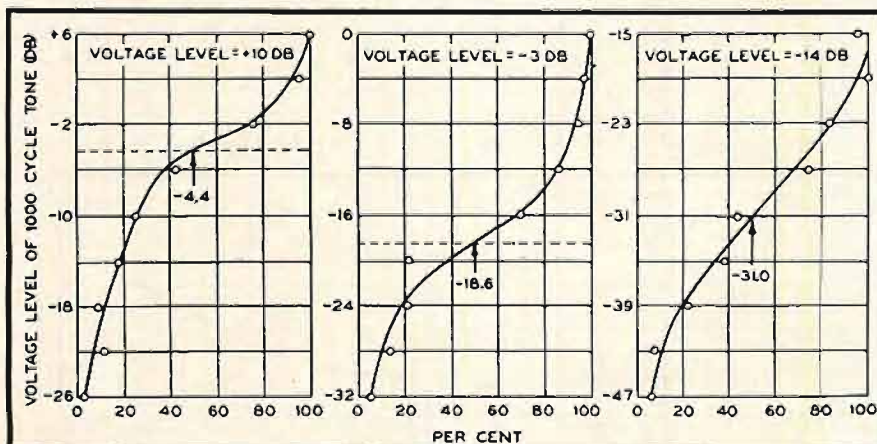

Fig. 17. Percent of observations estimating 1000-cycle tone to be louder than 125-cycle tone.

now you  
can record  
your own  
stereophonic  
tapes



THE FIRST AND  
ONLY FULLY  
STEREOPHONIC  
RECORDING AND  
PLAYBACK SYSTEM...  
AT AN AMAZING  
LOW PRICE!



**Sterecorder**

Now, you can actually record—as well as playback—stereophonic sound. The new STERECORDER captures all the realism of the original performance ... then reproduces this exciting "living sound" with full dimensional depth and direction.

STERECORDER goes beyond high fidelity and "half-way" stereo units with only monaural recording. Hear a demonstration today!

From the famous name in motion pictures:  
Superscope Inc., Audio Electronics Division,  
780 Gower St., Hollywood, Calif.

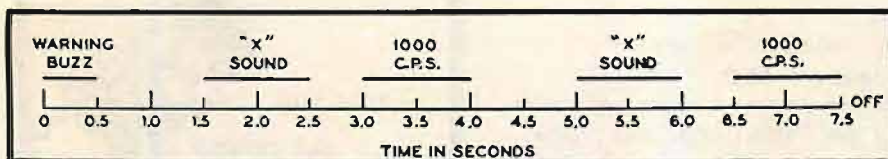

Fig. 18. Time sequence for loudness comparisons.

### APPENDIX B. COMPARISON OF DATA ON THE LOUDNESS LEVELS OF PURE TONES

A comparison of the present loudness data with that reported previously by B. A. Kingsbury<sup>4</sup> would be desirable and in the event of agreement, would lend support to the general application of the results as representative of the

using one ear (the voltages on the receiver remaining unchanged) he would still estimate that the two tones were equally loud. The results upon which this conclusion is based are shown in Table XVI. In the first row are shown the frequencies of the tones tested. Under these frequencies are shown the differences in db of the voltage levels on the receivers obtained when listening

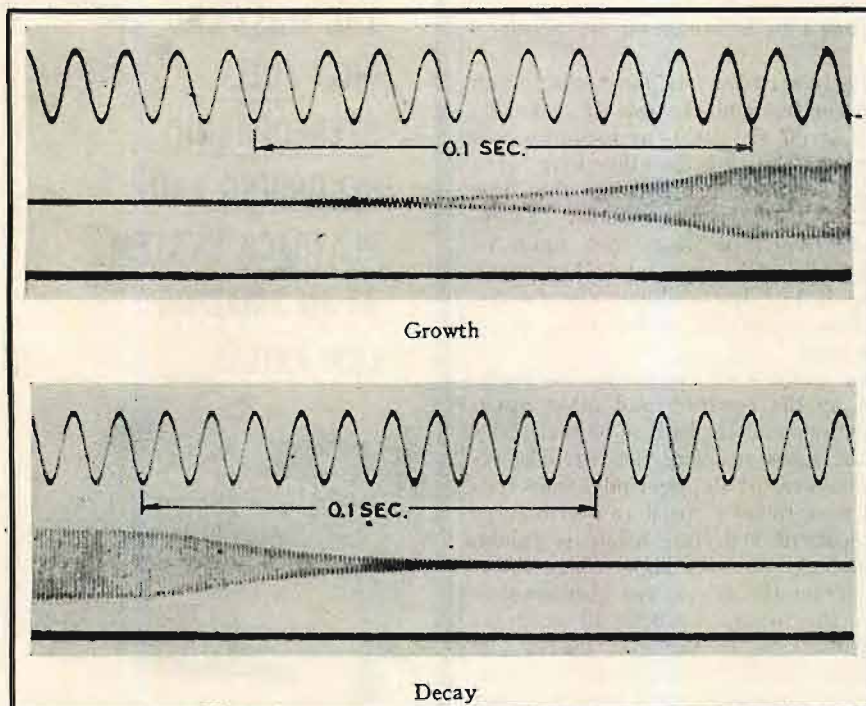

Fig. 19. Growth and decay of 1000-cycle reference tone.

average ear. It will be remembered that the observers listened to the tones with both ears in the tests reported here, while a single receiver was used by Kingsbury.

Also, it is important to remember that the level of the tones used in the experiments was expressed as the number of db above the average threshold current obtained with a single receiver. For both of these reasons a direct comparison of the results cannot be made. However, in the course of our work two sets of experiments were made which give results that make it possible to reduce Kingsbury's data so that it may be compared directly with that reported in this paper.

In the first set of experiments it was found that if a typical observer listened with both ears and estimated that two tones, the reference tone and a tone of different frequency, appeared equally loud, then, making a similar comparison

by the two methods, the voltage level of the reference tone being constant at 32 db down from 1 volt. Under the caption "Other Reference Tone Levels" similar figures for frequencies of 62 cps and 2000 cps and for the levels of the reference tone indicated are given. It will be seen that these differences are well within the observational error. Consequently, the conclusion mentioned above seems to be justified. This is an

important conclusion and although the data are confined to tests made with receivers on the ear it would be expected that a similar relation would hold when the sounds are coming directly to the ears from a free wave.

This result is in agreement with the point of view adopted in developing the formula for calculating loudness. When listening with one instead of two ears, the loudness of the reference tone and also that of the tone being compared are reduced to one half. Consequently, if they were equally loud when listening with two ears they must be equally loud when listening with one ear. The second set of data is concerned with differences in the threshold when listening with one ear *vs.* listening with two ears.

It is well known that for any individual the two ears have different acuity. Consequently, when listening with both ears the threshold is determined principally by the better ear. The curve in Fig. 20 shows the difference in the threshold level between the average of the better of an observer's ears and the average of all the ears. The circles represent data taken on the observers used in our loudness tests while the crosses represent data taken from an analysis of 80 audiograms of persons with normal hearing. If the difference in acuity when listening with one ear *vs.* listening with two ears is determined entirely by the better ear, then the curve shown gives this difference. However, some experimental tests which we made on one ear acuity *vs.* two ear acuity showed the latter to be slightly greater than for the better ear alone, but the small magnitudes involved and the difficulty of avoiding psychological effects caused a probable error of the same order of magnitude as the quality being measured. At the higher frequencies where large differences are usually present the acuity is determined entirely by the better ear.

From values of the loudness function  $G$ , one can readily calculate what the difference in acuity when using one *vs.* two ears should be. Such a calculation indicates that when the two ears have the same acuity, then when listening with both ears the threshold values are about 2 db lower than when listening with one ear. This small difference would

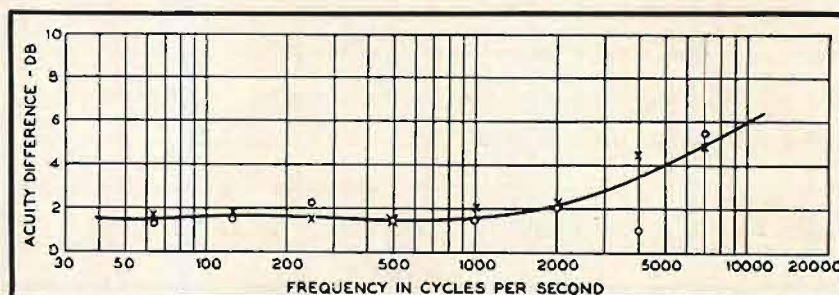

Fig. 20. Difference in acuity between the best ear and the average of both ears.

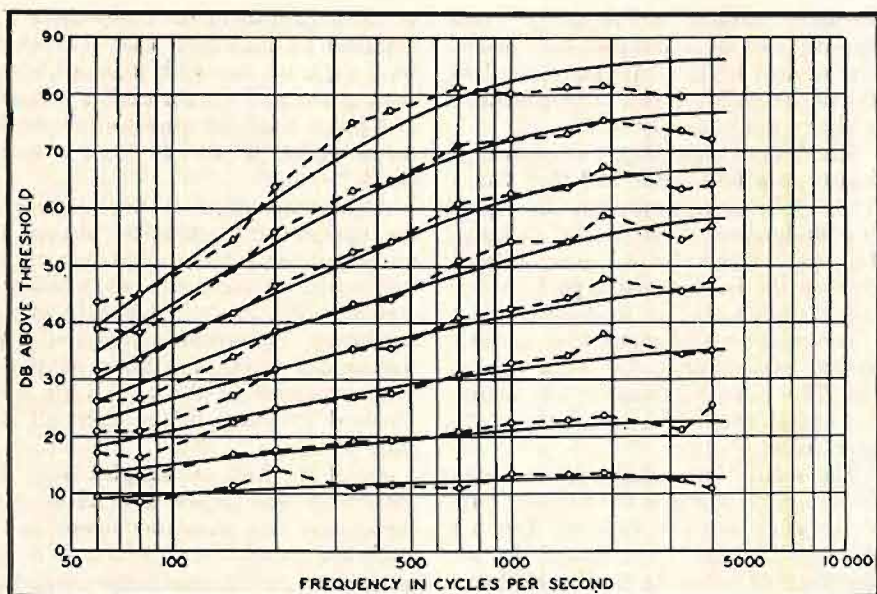

Fig. 21. Loudness levels of pure tones—A comparison with Kingsbury's data.

account for the difficulty in trying to measure it.

We are now in a position to compare the data of Kingsbury with those shown in Table I. The data in Table I can be converted into decibels above threshold by subtracting the average threshold value in each column from any other number in the same column.

If now we add to the values for the level above threshold given by Kingsbury an amount corresponding to the differences shown by the curve of Fig. 20, then the resulting values should be directly comparable to our data on the basis of decibels above threshold. Comparisons of his data on this basis with those reported in this paper are shown in Fig. 21. The solid contour lines are drawn through points taken from Table I and the dotted contour lines taken from

Kingsbury's data. It will be seen that the two sets of data are in good agreement between 100 and 2000 cps but diverge somewhat above and below these points. The discrepancies are slightly greater than would be expected from experimental errors, but might be explained by the presence of a slight amount of noise during threshold determinations.

#### APPENDIX C. OPTICAL TONE GENERATOR OF COMPLEX WAVE FORMS

For the loudness tests in which the reference tone was compared with a complex tone having components of specified loudness levels and frequencies, the tones were listened to by means of head receivers as before; the circuit shown in Fig. 15 remaining the same excepting for the vacuum tube

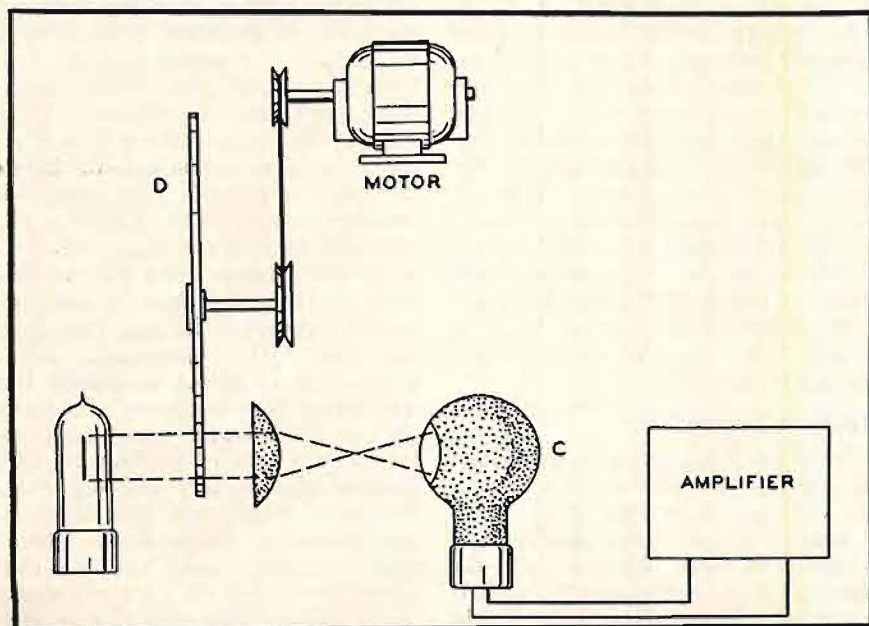

Fig. 22. Schematic of optical tone generator.

at  
last...  
clean  
record  
grooves...  
no static!



# LEKTROSTAT<sup>®</sup>

## RECORD CLEANING KIT

The only record cleaning kit *engineered* to clean record grooves! Contains the first functionally-designed groove-cleaning applicator and a recognized anti-static detergent. A few drops of Lektrostat and a few strokes of the special groove-cleaning applicator eliminates static... thoroughly cleans not only the surface but the *grooves*.

**\$2<sup>00</sup>** for complete kit



anti-static detergent    groove-cleaning applicator    plastic pouch

At your dealer or write:

**dexter** chemical corp.  
consumer products division

845 Edgewater Rd., New York 59

world's foremost chemical anti-static research organization.

**How to  
increase and enrich your  
understanding of music**

In this stimulating new book for the layman who wants to understand music more fully for complete listening enjoyment, the author shows you plainly how to evaluate your musical impressions and how to discover the specific musical elements and processes which create them. Filled with musical examples, the book provides tools for analyzing, evaluating, and appreciating music of all periods.

*Just Out!*

**MUSIC:**

**The Listener's Art**

By LEONARD G. RATNER  
Professor of Music, Stanford U.

370 pages, 6 x 9, 158 Musical Excerpts  
18 illustrations, \$7.50

**T**HE qualities of sound—how loud or strong, what level or pitch, and the special colors — are presented through the analysis of works of such composers as Beethoven, Ravel, Mendelssohn, and Mozart. Next the movement of musical sound is assessed—how fast, how smooth, how regular or irregular, how gentle or forceful. The arrival of the movement itself—gentle, forceful, clear, doubtful, tentative, final—is also discussed.

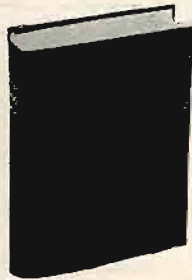

Once acquainted with the devices used by composers to stir the listener's feelings and senses, you are introduced to music through the ages, with explanations of how musical forms have evolved from the earliest medieval plain song to modern experimental compositions.

**Contents**

- |   |                      |
|---|----------------------|
| 1. The Musical Experience                   | 4. Renaissance Music |
| 2. Musical Elements and Their Relationships | 5. Baroque Music     |
| 3. Medieval Music                           | 6. Classic Music     |
|   | 7. Romantic Music    |
|   | 8. Modern Music      |
|   | 9. Retrospect        |

**SEE THE BOOK 10 DAYS FREE**

**RADIO MAGAZINES, INC.**  
P.O. Box 629, Minneola, N. Y.

Send me Ratner's **MUSIC** for 10 days' examination on approval. In 10 days I will remit \$7.50 plus few cents for delivery costs, or return book postpaid. (We pay delivery costs if you remit with this coupon; same return privilege.)

(Print)  
Name .....  
Address .....  
City ..... Zone ..... State .....  
Company .....  
Position .....

oscillator marked "x Frequency." This was replaced by a complex tone generator devised by E. C. Wente of the Bell Telephone Laboratories. The generator is shown schematically in Fig. 22.

The desired wave form was accurately drawn on a large scale and then transferred photographically to the glass disc designated as *D* in the diagram. The disc, driven by a motor, rotated between the lamp *L* and a photoelectric cell *C*, producing a fluctuating light source which was directed by a suitable optical system upon the plate of the cell. The voltage generated was amplified and attenuated as in the case of the pure tones.

The relative magnitudes of the components were of course fixed by the form of the wave inscribed upon the disc, but this was modified when desired, by the insertion of elements in the electrical circuit which gave the desired characteristic. Greater flexibility in the control

of the amplitude of the components was obtained by inscribing each component on a separate disc with a complete optical system and cell for each. Frequency and phase relations were maintained by mounting all of the discs on a single shaft.

An analysis of the voltage output of the optical tone generators showed an average error for the amplitude of the components of about  $\pm 0.5$  db, which was probably the limit of accuracy of the measuring instrument. Undesired harmonics due to the disc being off center or inaccuracies in the wave form were removed by filters in the electrical circuit.

All of the tests on complex tones described in this paper were made with the optical tone generator excepting the audiometer, and two tones tests. For the latter tests, two vacuum tube oscillators were used as a source.

THE END

**FEEDBACK AND DISTORTION**

(from page 32)

already seen,  $R_1 = 1/g_0' - 1/g_0$ , so that  $R_1 = 0.714 - 0.0714 = 0.6426$  ohms. (There is a small error here, because I should have taken  $0.7143 - 0.0714 = 0.6429$ , but we shall be dropping the last significant figures so it does not really matter). Now we go down our table adding  $0.6426$  ohms to each value of  $1/G$ , and thus obtaining the corresponding value of  $1/G'$ . Back to the table of reciprocals and we have a table of  $g'$ . Each value of  $G'$  is the value we get for a particular input, the one corresponding to the initial value of  $G$ . Using the scale on the left, which is exactly one-tenth of the  $G$ -scale (and that is why I chose 20db, in spite of the inconvenience of  $0.6426$ ) we have the  $G'$  curve shown in Fig. 3.

As I showed in the article to which I referred previously, a transconductance curve like the straight line of  $G$  corresponds to the production of second harmonic only, and the amount of second harmonic is proportional to the slope of the curve. Around *P* the  $G'$  curve is also approximately a straight line and the slope is one-tenth of what it was. On the line *Y*, for example, the change of  $G$  is 6 A/V while the change of  $G'$  is only 0.046, so that  $\Delta g'/g'$  is actually more than 10 times reduced compared with  $\Delta g/g$ .

**High-Level Signals**

When the input swing is more than about 60 mv, however, matters start to look different. That rapid fall-away of  $G'$  means that there is a correspondingly rapid rise in slope. What is more, for these larger amplitudes the  $G'$  curve is certainly not to be treated as a straight line. We have the curved transconduc-

tance characteristic which means that there is third harmonic produced. What is more, the curve just does not look like a parabola, so that we must have some higher harmonics too, though I don't propose to work these out.

It is not difficult to see what is happening. When we swing up to *Y* the transconductance rises to 20 A/V, so that there is more loop gain to knock down the second harmonic. That is why we get less than we expected in that direction. But down at *X*, for example, the value of  $G$  is only 4 A/V and therefore instead of there being 20 db of feedback there is only about 9 db. I do not propose to calculate any particular distortion figure to show just how much the feedback advantage falls below 20 db, because it is not possible to apply them to give any general rules. It is, I think, quite easy to see from the  $G'$  curve in Fig. 3 that there will be a very rapid rise in distortion once the knee of the curve is reached. This agrees with common experience: the distortion without feedback increases fairly steadily as the level is increased but with feedback it increases slowly up to a quite well defined overload point and then shoots up suddenly. This is particularly marked if you plot the output in decibels. I am well aware that engineers who started life in the kilowatt class think very little of the idea of plotting output in decibels because, they say, one decibel may mean 10 kilowatts in a big broadcast transmitter. While that is true, the studio engineer usually has his controls marked in db and his VU meter marked in db, and he knows that his listeners' ears are, as it were, calibrated in deci-

bels. Anyway, all we want to do is to show clearly the overload point.

### Voltage Feedback

All the discussion above is based on the assumption that we have current feedback and uses the idea of transconductance. What happens if we have voltage feedback: After all, that is what we are generally going to use. I have carried through the analysis of the case of an amplifier having a current input and voltage output, with voltage feedback. Here we define a transimpedance, the volts per amp—the amps, of course, being actually the current in the grid leak which acts as combining network for input and feedback. If the amplifier transconductance is  $R$  without feedback, reduced to  $R'$  with feedback, and the feedback conductance is  $G_f$ , the basic equation reduces to

$$\frac{1}{R'} = \frac{1}{R} - g_f$$

Apart from the fact that we must subtract instead of adding, this is of the same form as the equation we started with in discussing the current feedback case. I think it is pretty safe to say that we should find that the whole analysis followed along much the same lines. The only trouble is that it is not so easy to work out the distortion in the transimpedance case, so I do not propose to reproduce the whole thing here. In the classic formula for feedback

$$\mu' = \mu / (1 + \mu\beta)$$

we can write, instead,

$$\frac{1}{\mu'} = \frac{1}{\mu} + \beta$$

Again we see that the basic form is reproduced and that it is fair to accept the reasoning from transconductance as applicable to any form of feedback. The fact that the distortion may be harder to calculate does not affect the basic ideas.

A study of Fig. 3 with intermodulation in mind is very interesting. We usually consider the situation where the input is made up of two tones, one of low frequency and large amplitude, the other of high frequency and small amplitude. The low-frequency signal moves the effective working point for the high frequency signal to and fro along the  $G'$  characteristic. Basically we can say that the gain at the high frequency is being varied but, if the amplitudes are not large, not by very much. As the low-frequency amplitude is increased, however, the working point moves on the peak down into the region of  $X$  and not only is the intermodulation increased but during these peaks the distortion of the high-frequency signal is increased, too. The basic characteristic  $G$  will produce only second-order prod-

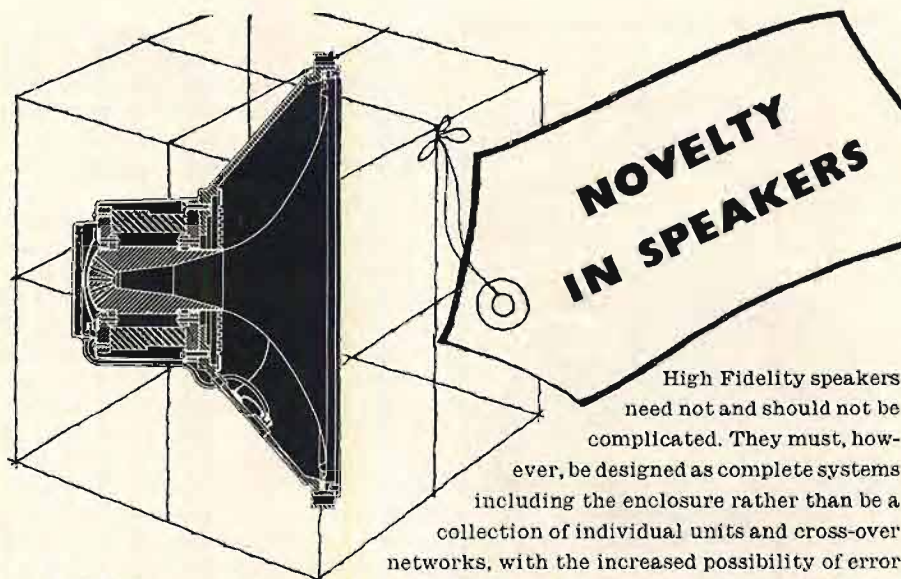

### BASIC SPECIFICATION

12" and 15" models

Frequency response  
30—20,000 c.p. ± 3dB.

Polar Distribution for  
60° inc. angle-4dB.  
at 10,000 c.p.s.

Intermodulation  
Products  
less than 2%

High Fidelity speakers need not and should not be complicated. They must, however, be designed as complete systems including the enclosure rather than be a collection of individual units and cross-over networks, with the increased possibility of error and the lack of necessary equipment for tests in the home when finally assembled. Few people would obtain a motor-car by buying the engine, chassis, body etc. and assembling it at home. They would rightly regard this as a job for expert engineers—and so with loudspeakers, where naturalness not novelty is the desired result.



DUAL CONCENTRIC SPEAKERS

TANNOY (AMERICA) LTD. 38 PEARL STREET, NEW YORK, 4, N.Y., U.S.A.  
TANNOY (CANADA) LTD. 36 WELLINGTON STREET EAST, TORONTO 1, ONTARIO, CANADA

## AN IMPORTANT MESSAGE—

To audio engineers, music enthusiasts, and students interested in the science of Acoustics and Musical Instruments.

From the distinguished Acoustical Instrumental Studio in Gravesano, Switzerland comes the—

### GRAVESANER BLATTER / GRAVESANO REVIEW

(English / German Edition) Edited by Hermann Scherchen

... dedicated to the contribution toward the more perfect reproduction of music through the science of acoustics and musical instruments. The GRAVESANO REVIEW is edited by Professor Hermann Scherchen, noted European conductor and musicologist. It begins its third year with Volume IX, reporting the meetings of the Acoustical Experimental Studio in Gravesano, Switzerland. Issued quarterly, subscription is now available in the United States by special arrangement with Radio Magazines, Inc., publishers of Audio.

You may begin your subscription with Volume IX of the GRAVESANO REVIEW which is combined with the GRAVESANO SCIENTIFIC RECORD, a 33 1/3 rpm LP demonstration record.

Partial list of contents in Volume IX:

(all articles appear in both English and German)

The Modulor, Concentration instead of Expansion, Acoustics and Large Orchestral Studios and Concert Halls, Psychoacoustical Phenomena accompanying natural and synthetic sounds. The Ear—a time measuring instrument, Experience with a new high quality loudspeaker for control booths. Tuning the Oboe. Accompanying Volume IX: THE GRAVESANO SCIENTIFIC RECORD contains a demonstration of the Frequency Regulator of Anton Springer of Telefon-Und Apparatebau AG., Frankfurt/Main.

Issued quarterly, THE GRAVESANO REVIEW is accompanied with a GRAVESANO SCIENTIFIC DEMONSTRATION RECORD.

Single copies not for sale, by subscription only, \$6.00 per year, postpaid.

Exclusive United States Subscription Agency:

**RADIO MAGAZINES, INC.**

MINEOLA, N. Y.

**RADIO MAGAZINES, INC., SUBSCRIPTION DEPT. GBA P. O. BOX 629, MINEOLA, N. Y.**

Please enter my subscription to GRAVESANO REVIEW and accompanying SCIENTIFIC DEMONSTRATION RECORD. I enclose the full remittance of \$6.00.

Name \_\_\_\_\_

Address \_\_\_\_\_

City \_\_\_\_\_ Zone \_\_\_\_\_ State \_\_\_\_\_

available now ...

## the much talked about ISI Tape Recorder

with the  
magnetic clutch drive

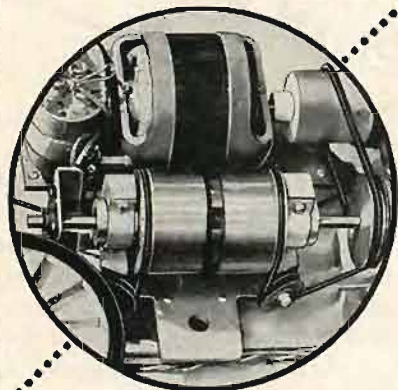

the most talked about  
development in the industry

### features

- Magnetic clutch braking and tape tension control — fool proof and virtually fool proof. Handles tape under all conditions and at all speeds without the possibility of spilling or breakage.
- Synchronous tape drive at 3 3/4 and 7 1/2 ips or 7 1/2 and 15 ips.
- Mounting space for six heads in all presently used head configurations.
- Designed for rack mounting with integral amplifier.
- Dual inputs and controls for mixing line and high impedance inputs.

THE ISI IS AVAILABLE NOW FOR EARLY DELIVERY ON A DIRECT FACTORY TO USER BASIS.

A truly professional piece of recording gear, the ISI is ideally suited for the serious audiophile, military and industrial data recording and the commercial recordist — priced from \$345. The price of the machine is determined by the head compliment and accessory fittings.

For comprehensive information on this outstanding recorder write to:

**Mid-Continent Engineering, Inc.**  
1712 Marshall N.E. Minneapolis, Minnesota

### IF YOU ARE MOVING

Please notify our Circulation Department at least 5 weeks in advance. The Post Office does not forward magazines sent to wrong destinations unless you pay additional postage, and we can NOT duplicate copies sent to you once. To save yourself, us, and the Post Office a headache, won't you please cooperate? When notifying us, please give your old address and your new address.

Circulation Department  
**RADIO MAGAZINES, INC.**  
P. O. Box 629, Mineola, N. Y.

ucts but the use of feedback results in the production of products of much higher order. What does this sound like? Well, if you have taken the trouble to provide feedback to keep the system linear you ought to take trouble to prevent the level being too high.

In a carefully designed amplifier with push-pull output the curve we start with, the overall transconductance curve, will probably look something like Fig. 4. Over the center portion which is all we shall expect to use the variation of transconductance will not be very large, so that the classical theory will be very close to exact. It is not really too bad even in the single-ended amplifiers if you remember that you will probably still be using the amplifier after the tubes have got past their first youth. A prudent designer would certainly expect to lose 2db per stage, perhaps even more, so that the feedback should be planned to have at least 6db in hand. A typical case I calculated some time ago which checked very well with practice showed that the apparent feedback,

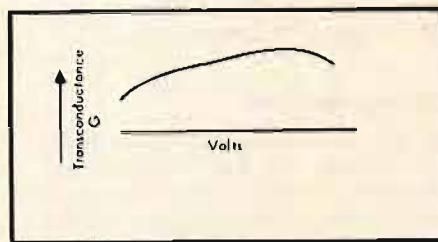

Fig. 4. With a push-pull input stage, both ends of the characteristic are curved while earlier stages provide a "second-harmonic slope."

judged by the distortion, was 3db less than the gain reduction.

I hope that this analysis, simple though it is, has convinced you that there is nothing wrong with the theory of distortion reduction by feedback, but only with the way that some people have applied the theory. In fact, as I said at the beginning, it is the experimental results you need to look at more closely and here you need to question yourself about the meaning of "gain before feedback applied." **Æ**

## ELECTRONIC SWITCH

(from page 28)

fore the auxiliary stage has a very high plate impedance when the pilot signal is on and a low one when the pilot signal is off. This impedance, controlled by the pilot signal, is connected in parallel to the screen grid of a pentode. Therefore this pentode is cut off when there is no pilot signal, owing to the short-circuit action of the auxiliary stage. When the pilot signal arrives, a negative voltage is developed on the grid of the auxiliary stage which is then cut off. The screen of the pentode is no longer short-circuited to earth by the auxiliary stage and a positive potential builds up on it. Therefore the pentode can freely amplify the incoming audio signal.

Figure 3 is the complete schematic of the electronic switch, together with the filter networks as developed and built for laboratory tests. The filters are very simple, but more elaborate circuits could be used if steeper attenuation curves are required. As can be seen there are no costly high-values inductances; the small values used can quickly be done with TV linearity coils with a moving core of ferrite. However their values must have a tolerance no more than  $\pm 2$  per cent and must therefore be measured with an impedance bridge. The whole circuit can be assembled in a small box and can be fed by the voltage supply circuit of the amplifier.

The low-pass filter, with a 7000 cps boundary frequency, has an input impedance,  $R_i$ , of 440 ohms, and the matched load impedance is 440 ohms,

also. The filter is made of three separate sections. The first two are equal and consist of series inductances  $L_s$  and parallel capacitances  $C_p$ , in constant-k L-shaped sections, as can be seen in Fig. 4. The third section is  $m$ -derived section ( $m = 0.65$ ) and consists of the series inductance  $L_{sm}$ , the series capacitance  $C_{sm}$  and the parallel capacitance  $C_{pm}$ .

The high-pass filter has been designed in the same way as the low-pass filter, with a boundary frequency of 8000 cps, as can be seen in Fig. 5. The input impedance is 7000 ohms, which is also the value of the load impedance.

It is necessary to point out the input impedance to the filter network is 360 ohms. It is a rather low impedance and this must, of course, be kept in mind in the design of the output stage of the preamplifier.

The first (a) section of the double triode 12AX7 is used as an amplifier, the second (b) as the auxiliary stage. The amplified pilot signal is rectified by the germanium diode which short-circuits the positive half cycles and

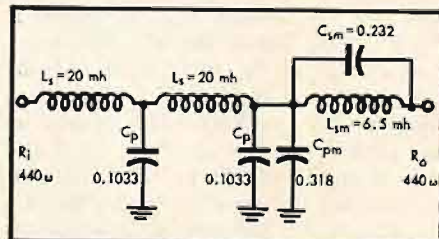

Fig. 4. Low-pass filter, with design components.

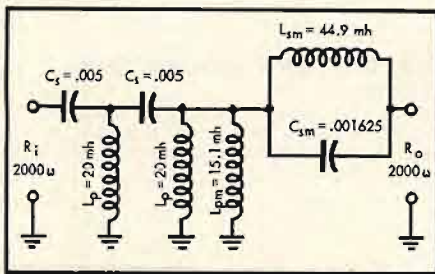

Fig. 5. High-pass filter, with design components.

thus only the negative ones are sent to the simple RC filter which filters out all a.c. signal still present. The negative potential is then sent to the second section (b) of the 12AX7 which makes up the auxiliary stage. The plate of the second section is connected to the screen grid of the pentode, a 6AV6, and its potential is established by the voltage divider made by the screen grid resistance 150,000 ohms, and the plate-cathode resistance of the 12AX7(b). In order to improve the cut-off of the pentode when the 12AX7(b) has a low plate resistance, the cathode of the 6AV6 is maintained at a high voltage by a voltage divider consisting of the

The output impedance is 100,000 ohms and therefore the power amplifier should have a high input impedance and should be located nearby to minimize hum pick-up and frequency discrimination.

#### Preamplifier

Figure 6 is a complete schematic of a suitable preamplifier. There are two double triodes, a 12AX7 and a 12BH7, which is seldom used in audio circuit but has been found useful by the author for driving purposes when a low driving impedance is required. The input transformer must, of course, be fully shielded from the strong magnetic fields usually present and the whole preamplifier should be kept far from the power supply, which is usually necessary with any preamplifiers.

This circuit, except for the 12BH7 which replaces the usual 12AX7 is rather conventional.

An interesting problem should be that of transistorizing this amplifier. Owing to the low input impedance of transistor amplifiers, no input transformer is required. A low-noise transistor must be used for the first stage, and its working

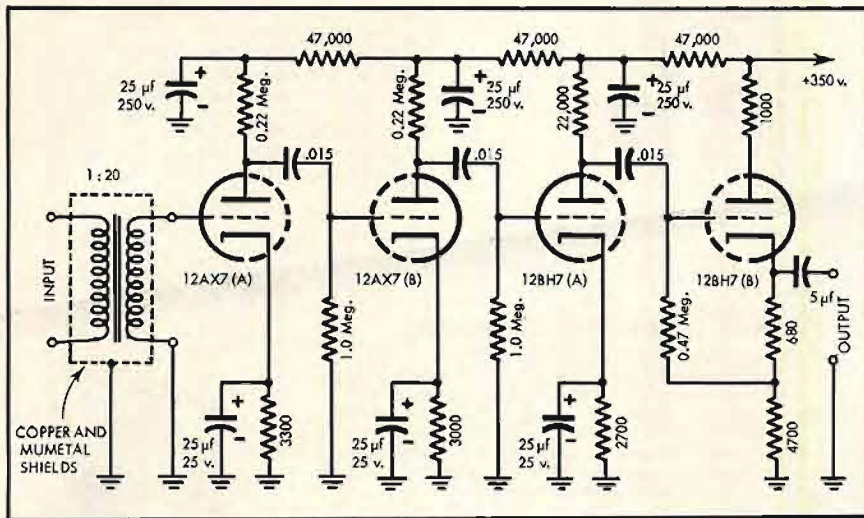

Fig. 6. Preamplifier, with electronic tubes, for a theatre Cinemascope magnetic sound system.

resistance  $R'_x$ , bypassed by an  $8\mu\text{f}$  capacitor and of the resistance  $R''_x$ , which must have a value so that in absence of the pilot signal the screen grid is 20 volts negative with respect to the cathode. This condition is certainly quite sufficient to cut off the pentode completely.

In order to improve the time constant of the regulation a 12,000-ohm resistor and an  $8\text{-}\mu\text{f}$  capacitor in series shunt the plate of the 12AX7(b). The time constant,  $T$ , then is:

$$T = RC = 12,000 \times 8 \times 10^{-6} \text{ sec} = 96 \times 10^{-3} \text{ sec}$$

This value is usually sufficiently low to allow a good transient response.

conditions must be the optimum for low-noise operation. Capacitor coupling and four or five common-emitter stages, depending on the types of transistors used, should be sufficient for the whole preamplifier. Transformer coupling is not recommended owing to the difficulties of shielding. From 10 to 20 db of negative feedback would prevent appreciable variation in the gain of the circuit due to the battery supply voltage variations and temperature effects. The author has recently built many transistor amplifiers of this kind for other purposes and found them quite reliable, although not economically more convenient than electron tube amplifiers.  $\text{AE}$

## pioneer

### Now you can have "Directional Fidelity"

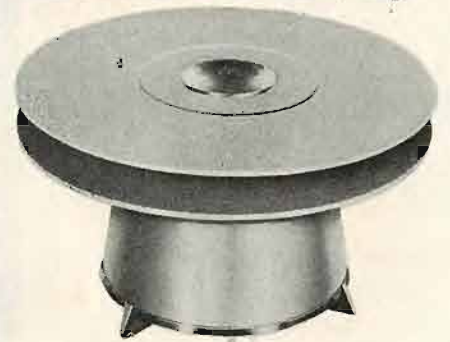

In the past, the directional characteristics of high frequency signals was a major problem in the designing of high fidelity speakers.

When listening to actual sound, the sounds are the same no matter what direction a person may be listening from, as long as he is at an equal distance from the source of the sound.

However, in the case of sounds emanating from a speaker, there is a great difference between listening while positioned in front of the speaker on its axis and while listening from other positions. Thus, the service area of high frequency speaker units manufactured in the past was, at the most, a mere 30 degrees.

The PIONEER PT-01 has increased this range to 360 degrees in a single bound, and it is the world's first omni-directional tweeter that sounds the same no matter what direction the listener is listening from.

This PIONEER CS-01W consists of a 6.5" mechanical two-way speaker put in a sphere-shaped enclosure that is ideal enclosure form from the point of diffracting effects. Furthermore, it is the only omni-directional speaker that has a 360 degrees service area on a horizontal plane, in the same manner as the PT-01.

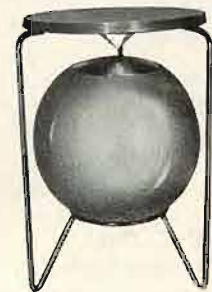

Write for catalog to:—

**FUKUIN ELECTRIC**  
6-5 Otowacho, Bunkyo-ku, Tokyo, Japan.

# the AUDIO bookshelf

A convenient service to AUDIO readers. Order your books leisurely by mail—save time and travel, we pay the postage.

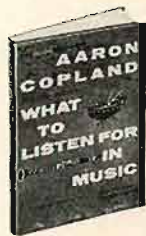

**No. 113**  
Revised Edition  
**WHAT TO LISTEN FOR IN MUSIC**  
by Aaron Copland  
Deems Taylor says... "The best book of its kind I have ever seen." With this book, which has brought greater listening pleasure to thousands, you will learn how to listen from a composer's point of view. If you love music, you will love this book! \$3.95 Postpaid.

**No. 115**  
**McPROUD HIGH FIDELITY OMNIBOOK**  
by C. G. McProud  
Prepared and edited by C. G. McProud, publisher of Audio and noted authority and pioneer in the field of high fidelity. Contains a wealth of ideas, how to's, what to's and when to's, written so plainly that both engineer and layman can appreciate its valuable content. Covers planning, problems with decoration, cabinets and building hi-fi furniture. A perfect guide to help you plan, arrange and select components for a hi-fi system. \$2.50 Postpaid.

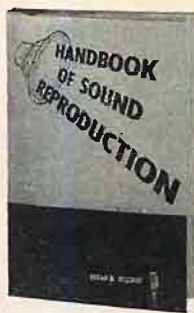

**No. 110**  
**HANDBOOK OF SOUND REPRODUCTION**  
by Edgar M. Villechur  
Right up to date, a complete course on sound reproduction. Covers everything from the basic elements to individual chapters of each of the important components of a high fidelity system. \$6.50 Postpaid.

**No. 111**  
Revised Edition  
**ELECTRONIC MUSICAL INSTRUMENTS**  
by Richard H. Dorf  
In one large volume, here are all of the intricacies of the electronic organ and smaller instruments. Construction drawings and details of the author's own Electronorgan plus commercial models such as the Allen, Baldwin, Hammond, Connsnata, etc. \$7.50 Postpaid.

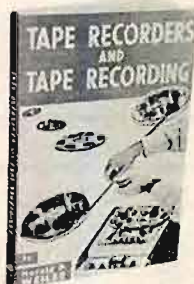

**No. 112**  
**TAPE RECORDERS AND TAPE RECORDING**  
by Harold D. Weiler  
A complete book on home recording by the author of *High Fidelity Simplified*. Easy to read and learn the techniques required for professional results with home recorders. Covers room acoustics, microphone techniques, sound effects, editing and splicing, etc. Invaluable to recording enthusiasts. *Hard Cover \$3.95. Paper Cover \$2.95 Postpaid.*

**No. 114**  
Revised Edition  
**THE NEW HIGH FIDELITY HANDBOOK**  
by Irving Greene and James R. Radcliffe  
With Introduction by Deems Taylor who says "...Messrs. Greene and Radcliffe, two gentlemen whose knowledge of hi-fi is only slightly less than awesome... Read it through, and you will arise full of knowledge." A complete and practical guide on high fidelity; covers planning, buying, assembly, installation, and building hi-fi furniture. \$4.95 Postpaid.



**No. 116**  
**THE 3rd AUDIO ANTHOLOGY**  
by the editors of Audio Magazine  
A condensed library of essential high fidelity knowledge in one single volume. A valuable collection of the most useful audio techniques published in Audio Magazine... the original magazine about high fidelity. 47 complete articles written by world famous authorities—fully illustrated, with schematics, pictorial diagrams and photographs. \$2.50 Postpaid.



## AUDIO Bookshelf

RADIO MAGAZINES, INC., Dept. A  
P.O. Box 629, Mineola, New York

Please send me the books I have circled below. I am enclosing the full remittance of \$.....(No. C.O.D.)  
All U.S.A. and CANADIAN orders shipped postpaid. Add 50¢ for Foreign orders (sent at buyer's risk).

BOOKS: 110 111 112 113 114 115 116

NAME \_\_\_\_\_

ADDRESS \_\_\_\_\_

CITY \_\_\_\_\_ ZONE \_\_\_\_\_ STATE \_\_\_\_\_

## HORN ENCLOSURES

(from page 23)

assembly, shock-mounted turntable, and so on, because hum, rumble, and perhaps acoustic feedback will show up and must be completely eliminated, if you want to benefit fully from the capabilities of this ultra-wide-range speaker system.

On the credit side we must consider that recorded tapes and LP discs are now recorded to lower and lower frequencies, and already many have frequencies of 20 to 32 cps on them. We don't really need these low notes of the first octave to enjoy good music but because they are actually recorded they can cause distortion or hangover, and may blur the higher range. So if we want authentic bass reproduction, a lower cutoff is thus preferable for cleanliness of response, naturalness, definition and to obtain the required sound power output from these low frequencies with the least possible distortion. Many systems that were fairly good some years ago are now showing signs of deficiencies in the low range because of these new recordings.

Ordinarily in the big corner systems, the bass driver is concealed behind a panel, and the listener must be at a distance of 15 to 20 ft to hear a properly blended sound. In this model, the width of the front baffle has been reduced to only 28 in.

Considering that it already has frontal radiation from the woofer and that the mouth was designed with this objective in mind, we are now able to obtain a proper blending of sound only a few feet from the speaker system. This is a real advantage in a small room. Also, because of the fact that the woofer is located not in the bottom of the enclosure but in the top part just under the M.F. and H.F. units, a single-sound-source effect is obtained at a nearer distance for a person singing or for a solo instrument.

When located in a room about twice longer than large, this horn, because of its complete back side panels, may be turned three or five inches to face the longer side of the room. Better high frequency dispersion is obtained with somewhat better appearance, and this small displacement will not affect at all its low end performance.

In conclusion, when compared size for size with other corner horns, this custom enclosure has the following advantages:

1. Hypex flare for more efficiency in the cutoff region and above.
2. Greater density, total weight being about 350 lbs.
3. Extreme rigidity.
4. Lower cutoff, longer path length, and larger mouth (1056 sq. in.).

5. Effective mouth area in corner, 8448 sq. in.

6. Complete back side panels with no air leaks, no cut corners, no wall resonance.

It has the best low end performance that the writer has ever heard. You must hear it to believe it, so build one right now.

### Construction Data

I regret very much to say that I have no photo of the second horn. The reason is that as soon after its completion, the horn was moved to a friend's audio room for panel listening but it was destroyed by fire after only three weeks of fine operation. This regrettable and costly incident occurred before I had the chance to photograph the horn and I don't know now when I will be able to undertake its reconstruction. To compensate for this I'll try to give as much information as possible on its construction.

Constructional drawings are shown in Figs. 4 and 5.

The inside dimensions of the expanding air column should be adhered to very strictly. With a difference of only one or two in. at the beginning of this air column, you will not be able to fold it in the same manner in the enclosure and you will arrive at the end with a loss of 6 to 10 in. in the path length. This will result in a smaller mouth with its disadvantages. Table III shows dimensions and area for every six inches of the horn path indicated in Figs. 4 and 5.

TABLE III

| Distance from throat in. | Dimensions in. | Corner posts sq. in. | Area sq. in. |
|--------------------------|----------------|----------------------|--------------|
| 0                        | 3 3/8 x 25     | - 3                  | 80           |
| 6                        | 3 3/4 x 25     | "                    | 91           |
| 12                       | 4 1/4 x 25     | "                    | 103          |
| 18                       | 5 x 25         | "                    | 122          |
| 24                       | 5 3/4 x 25     | "                    | 140          |
| 30                       | 6 1/2 x 25     | Average width        | 162          |
| 36                       | 7 1/2 x 25     | "                    | 187          |
| 42                       | 8 3/4 x 25     | "                    | 219          |
| 48                       | 10 1/2 x 25    | "                    | 262          |
| 54                       | 14 1/2 x 21    | "                    | 306          |
| 60                       | 30 x 12        | "                    | 360          |
| 62                       | 39 x 10        | "                    | 390          |
| 66                       | 44 x 5         | x 2 sides            | 440          |
| 72                       | 44 x 6         | "                    | 528          |
| 78                       | 44 x 7         | "                    | 616          |
| 84                       | 44 x 8 1/4     | "                    | 726          |
| 90                       | 44 x 10        | "                    | 880          |
| 96                       | 44 x 12        | "                    | 1056         |

Study the dimensions carefully in Figs. 4 and 5 and make a full size drawing on cardboard.

Except for corner posts, cleats, and

## AT LEONARD RADIO

IT'S  
**SHERWOOD**  
FOR TOP VALUE

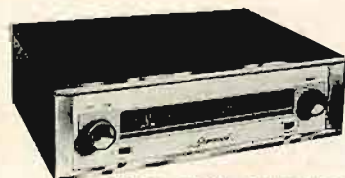

With New "Feather-Ray" Tuning Eye

**FM-AM Tuner S-2000.** Engineered and styled to match the performance of the incomparable S-1000 II Amplifier, this tuner offers features not previously available in this price range. These include 0.95 uv (20 db quieting) FM sensitivity, cascade 6BS8 balanced input, automatic frequency control, flywheel tuning, wide/narrow AM switch, (15-ke "hi-f") bandwidth or 5-ke selective bandwidth), precision calibrated dial, direct-able AM rod antenna, cathode-follower output, output level control, FM multiplex output, 10-ke "bridged-T" AM filter. Delayed AGC on FM reduces IM distortion to below 1/3% at 100% modulation. 11 tubes plus rectifier. New "Feather-Ray" tuning eye. Dimensions: 14 x 10 1/2 x 4 in. high, 47 watts, fused. Shipping Weight: 18 lbs.

Model S-2000 Chassis ... \$139.50; Model A or B ... \$144.50; Model C ... \$149.50; Models J, T, or W ... \$154.50.

Model S-3000—FM Tuner only; same FM specifications as the Model S-2000 PLUS "local-distance" switch to suppress cross-modulation responses.

Model S-3000 chassis ... \$99.50; Model S-3000 A or B ... \$104.50; Model C ... \$109.50; Models J, T, or W ... \$114.50; west of Rockies, add \$3.00 to above prices.



With New "Presence" Rise Button and DC filaments

**S-1000 II—36 Watt Amplifier.** This all new amplifier is designed to bring the maximum pleasure to music lovers—the greatest joy to the Hi-Fi expert.

Controls are simple, easy-to-handle, yet complete—include 6-db presence-rise switch, equalizer control for 4 record compensation choices or microphone and tape-playback equalization, inverse-feedback type bass and treble controls, Sherwood exclusive "center-set" loudness control, loudness compensation switch, 12-db/octave scratch and rumble filters, phono level control, tape-monitor switch, and selector for 5 inputs (including 2 with high-gain preamplifier)—all on front panel. Output tube balance control features adjustment without meters. Phono preamp and tone control amp. operated from quick warm-up type DC filament supply. Power Output: 36 watts (72 watts peak) at 1 1/2% IM Distortion (60:7kc/4:1). Outputs: 16, 8 and 4 ohms. Inverse Feedback: 21 db. Frequency Response at 36 w: 20-20,000 cps ± 1 1/2 db. Preamp Sensitivity 2 1/2 mv. Preamp noise level: 60 db below rated output. 85 watts, fused, 8 tubes, plus rectifiers. Size: 14 x 10 1/2 x 4 in. high. Shipping weight: 24 lbs.

Model S-1000 II chassis ... \$109.50; Model A or B ... \$114.50; Model C ... \$119.50; Models J, T, or W ... \$124.50; west of Rockies, add \$3.00 to above prices.

Mail & Phone Orders Accepted  
25% Deposit, Balance C.O.D.

**LEONARD RADIO, INC.**  
67 Convent St. New York 7, N.Y. COntact 7-0313

SAVE 1/2 — PAY PART-BY-PART — HAVE FUN

Assembling the **SCHOBER ELECTRONIC ORGAN** in KIT form



**NO SPECIAL SKILLS NEEDED**

Now you can afford a real, full concert organ, just like those made by the foremost organ manufacturers. Because over 1/2 the cost is saved when you assemble it yourself. And it's REALLY EASY: only 24 separate units, all with printed circuits, and detailed-to-the-smallest-step instructions. In addition, you purchase each of the 24 kits when you are ready for it — and can afford it.

You'll get a real kick out of putting the Schober Electronic Organ\* together — and then sitting down and pulling the stops for Strings, Trumpets, Clarinets, Diapasons, Flutes, etc. Electronic Percussion optional; chimes available.

**Compact CONSOLE**

One of the many exclusive features of this exceptional organ is the handsome console, in a wide variety of finishes. It is equally at home in a traditional or modern setting, and takes little more space than a spinet piano.

**Free Literature**

Complete descriptive booklet and price list are available on request. And, if you wish to hear the glorious pipe organ tone of the Schober Electronic Organ, a 10" long-playing demonstration recording is available for \$2. This is refundable when you order. Write today and see what a fine instrument you can get at such a great saving.

**The SCHOBER ORGAN CORP.**

2242 K Broadway, New York 24, N. Y.

\*Designed by Richard H. Dorf

Circle 76A

**Low Cost**

**4j FIBER GLASS**

**Speaker Baffles**

**MODEL IF5-8**

High quality 12" x 12" baffle of heavy duty Fiber Glass. Replaces one acoustical tile. Ideal for wall or ceiling mounting. Plaster rings and anti-compression full frequency rear housings available. For 8" speaker. Dir. net \$2.95.



**MODEL IFR-8**

Round design, 10 1/2" diameter. Great flexibility in all kinds of installations. Ideal for Super Markets, hotels, industrial applications. Use in ceiling, wall, or back-to-back with low cost 4j accessories. For 6" or 8" speakers. Dir. net \$2.25.



**ALSO AVAILABLE:** 4j Bass Reflex and Spiral Sound Baffles for high quality commercial sound and extremely low cost.

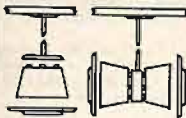

SEE YOUR DISTRIBUTOR OR WRITE FOR LITERATURE

**FOURJAY INDUSTRIES**

2360 West Dorothy Lane • Dayton 39, Ohio

Circle 76B

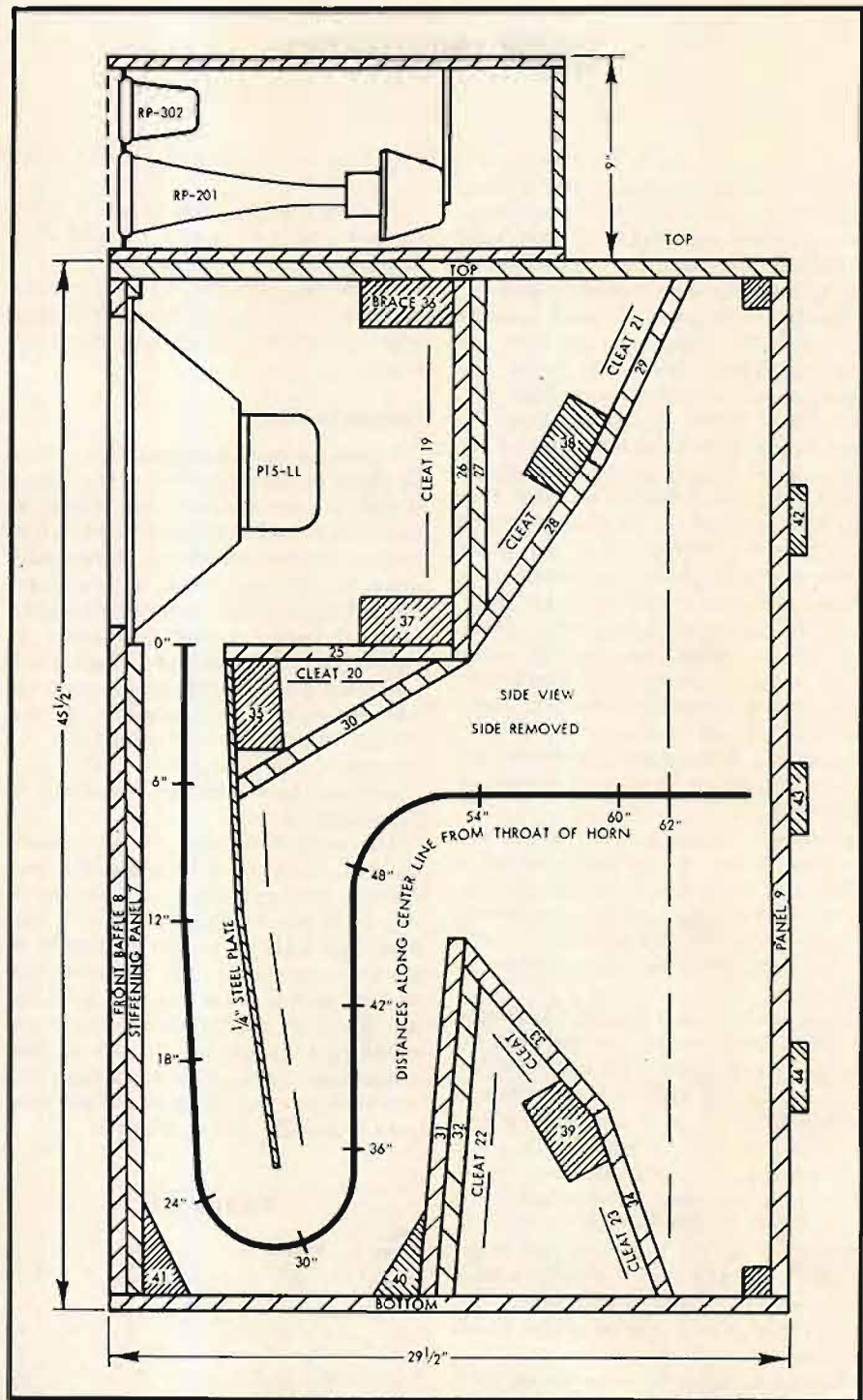

Fig. 5. Cross section of second type of horn through the center.

braces, use 3/4-in. 7-ply hardwood plywood throughout the construction. All joints should be airtight and adequately glued and screwed.

Use No. 8 screws, 1 1/4 and 1 1/2 in. long and special rubber base glue or casein glue to eliminate resonances which may be transmitted from one panel to another.

Cleats or glue blocks 1 in. square and of suitable lengths are used throughout for framing the top and bottom to the different panels and also in the inside of the cabinet for receiving the partitions or separators. The braces are 2

in. x 4 in.

The two front corners of the cabinet have 1 1/2 in. corner posts 44 in. long.

**Order of Assembling**

Follow the instructions given hereafter carefully because the cutting and assembling are a long task and you will save time if you do it in the order specified:

1. Cut top and bottom panels, lay out horn pattern, and fix cleats or glue blocks 12 to 18 inclusive to the bottom. Also fix similar cleats to the top.

AR<sup>INC</sup>

# QUOTATION

from  
*The Audio League Report\**

"We are now using the AR-1W as our reference speaker.

"As a result of extensive listening and laboratory tests, we are of the opinion that the AR-1W is one of the outstanding low-frequency reproducers available to-day. It may well be the most outstanding. At any rate, we do not specifically know of any other speaker system which is truly comparable to it from the standpoint of extended low frequency response, flatness of response; and most of all, low distortion."

\*Authorized quotation \$55. For the complete technical and subjective report on the AR-1 consult Vol. 1, No. 11 of the independent consumer periodical THE AUDIO LEAGUE REPORT, Mount Vernon, N. Y.

Prices for Acoustic Research speaker systems, complete with cabinets, (AR-1 and AR-2) are \$89.00 to \$194.00. Size is "bookshelf." Literature is available from your local sound equipment dealer, or on request from:

**ACOUSTIC RESEARCH, INC.**  
24 Thorndike St., Cambridge 41, Mass.  
Circle 77A

## Capps HOT-STYLUS UNIT



**LONGER STYLUS LIFE  
REDUCES LOADING ON CUTTING  
HEAD  
IMPROVES FREQUENCY RESPONSE  
IMPROVES SIGNAL TO NOISE RATIO  
FACILITATES PROCESSING  
EASILY INSTALLED AND OPERATED**

The CAPPS HOT-STYLUS UNIT is used for applying heat to disc recording styli, softening the disc material at the point of contact thereby producing smoother, more accurate grooves. This results in a substantial reduction in surface noise, especially at the inner diameters and minimizes the mechanical load on the cutting head increasing its efficiency and frequency response.

When ordering specify make and model number of cutter head and stylus requirements.

Model No.  
CU-1 Supplied without stylus . . . \$60.00 net  
CU-1R Supplied with regular duty stylus,  
LP or 78 . . . . . 66.50 net  
CU-1C Supplied with custom made stylus to  
customer's specification . . . . . 70.50 net

This complete unit may be obtained  
at your nearest dealer

**Capps & CO., INC.**  
20 Addison Place • Valley Stream, N. Y.

Circle 77B

2. Cut panels 1, 2, 4, and 5, 44 in. high, and fix them outside of the cleats between the top and bottom panels.

3. Cut panels 9, 10, and 11, same height, but do not fix them yet.

4. Lay out horn pattern on inside of panels 1, 2, 4, and 5.

5. Due to compound angles inside the cabinet, it is recommended that you do not cut the separators in the plywood first, but make a model of each with cardboard, because if you make an error, it is better to do it on cardboard than on costly plywood.

6. Fix brace 35 across the cabinet and the two cleats 20 on each side, on inside panels, then cut and fix separator 25.

7. Fix braces 36 and 37 and the two cleats 19; now cut and fix in order separators 26, 27, and 30.

8. Fix brace 38 and the two cleats 21, then cut and fix separators 28 and 29.

9. Fix the two cleats 24 to receive the steel plate later.

10. Fix brace 39 and cleats 22 and 23. Now cut and fix in order separators 31, 32, 33, and 34.

11. Cut a brace 2x4 in. diagonally and fix bottom corner 40.

12. Cut and fix the two corner posts 1½ in. square and 44 in. long to the two sides at 1½-in. from the front of the cabinet; then fix corner 41 at the bottom.

13. Cut and fix panels 3 and 6.

14. Cut the stiffening front panel 7, 25 by 44 in. and cut out a 14x16 in. rectangular hole at one inch from the top, but do not fix this panel at present.

15. Now before going farther, thoroughly sand all the inside surface of the

horn path to add smoothness and density to the plywood, including the outside of panels 1 and 4, and the inside of panels 7, 9, 10, and 11 already cut, but not yet fixed to the cabinet; give three coats of shellac and sand between each coat.

16. Now fix panel 9.

17. To add rigidity to the two large back side panels 10 and 11, fix three 1¼-in. dowels at a height of 11, 22, and 33 in. at the point indicated by the letter "A" on panel 1 and three others at the point indicated by the letter "B".

18. Repeat the same operation on panel 4 at "C" and "D".

19. During the construction, it was found that to obtain the required stiffness for the two back side panels, instead of using wood dowels which could not be lengthened after the panels 10 and 11 have been fixed, it was preferable to use plumbing supplies such as standard 1¼-in. wrought iron nipples (made from ordinary black pipe) and corresponding base flanges, female type, to receive these nipples. First, screw the base flanges to panels 1 and 4 at the required height; then screw in nipples about 5¾-in. long at point "A" and nipples about 7½ in. long at point "B". Now fix panels 10 and 11, and screw out each nipple so that the two back side panels acquire the extra stiffness necessary for complete elimination of vibration.

20. Cut and fix three horizontal stiffening members, 42, 43, 44, ¾ in. thick by 3 in. long at a height of 11, 22, and 33 in. on rear of back side panels 9, 10, and 11.

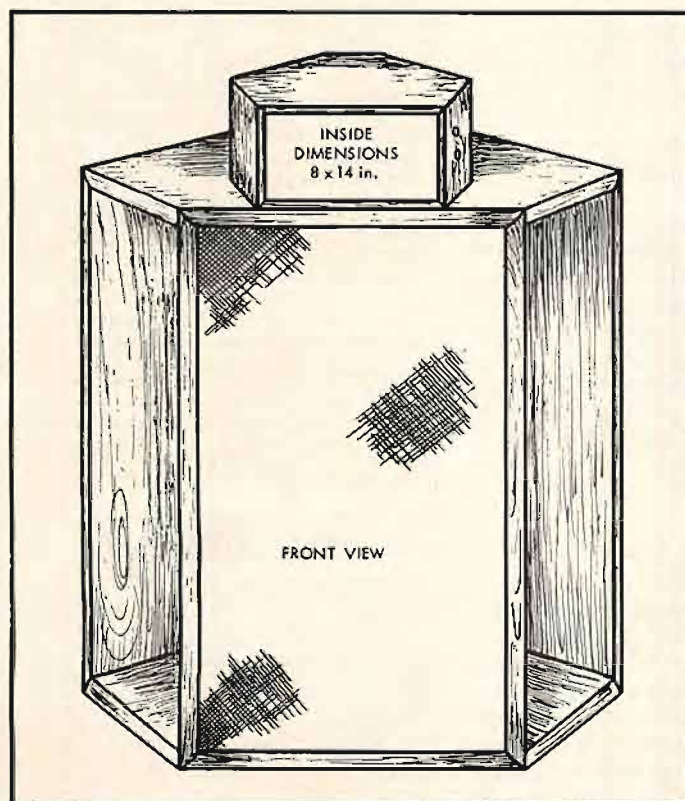

Fig. 6. Second corner horn type must be supplemented by mid- and high-frequency speakers; small box on top accommodates both.

**SAVE  
25%**



This is our

**GROUP SUBSCRIPTION PLAN**

Now you, your friends and co-workers can save \$1.00 on each subscription to **AUDIO**. If you send 6 or more subscriptions for the U.S., Possessions and Canada, they will cost each subscriber \$3.00 each, 1/4 less than the regular one year subscription price. **Present subscriptions may be renewed or extended as part of a group. Remittance to accompany orders.**

**AUDIO is still the only publication devoted entirely to**

- Audio
- Broadcasting equipment
- Acoustics
- Home music systems
- Recording
- PA systems
- Record Reviews

(Please print)

Name .....  
Address .....

New .....  Renewal .....

Name .....  
Address .....

New .....  Renewal .....

Name .....  
Address .....

New .....  Renewal .....

Name .....  
Address .....

New .....  Renewal .....

Name .....  
Address .....

New .....  Renewal .....

Name .....  
Address .....

New .....  Renewal .....

U. S., Possessions, and Canada only

**RADIO MAGAZINES, INC.**  
P. O. Box 629, Mineola, N. Y.

21. Cut six facing strips for the inside edges of the horn openings—two for the top, two for the bottom, and two for the sides. (Only the latter are shown in the drawings, affixed to panels 10 and 11 in Fig. 4.) These strips are triangular in cross-section, 3/4 by 3 in., and should be mitred at the corners of the horn openings.

22. Procure a 1/4-in. steel plate 23 x 25 in., making sure it has a smooth surface and is not rusted. Drill holes around the top and the two sides, the correct size to receive #8 screws (No. 16 drill). The plate should also be bent slightly, (about 4 deg.) in the middle in order to follow closely the first 24 in. of the expanding air column. Then screw the plate to brace 35 at the top and also to the cleats 24 already fixed on each side.

Fix the stiffening front panel 7 to the enclosure, prepare the front baffle (panel 8) and cut out a round hole of 13 1/4 in. diameter and mount the woofer. Before screwing the front baffle to the enclosure, be sure that all joints of this baffle and others of the sound chamber are completely airtight, then make a minimum sized hole through the top to pass the leads from the woofer to the crossover networks in the small cabinet. This hole must be sealed after the leads have been connected.

24. Make the small compartment on the top of the cabinet to place the M.F. and H.F. units, the two crossover networks, and the equalizer, and to mount the two controls outside, as shown in Fig. 6.

25. You may also add a 1 1/2-in. base to the cabinet if you prefer for appearance sake.

26. Cover the front baffle with a removable panel made of decorative molding with the interior finished in saran lumite grille cloth.

27. The front edge of the two sides may be covered with veneer or molding, or simply by lacquer.

28. Now mount your 3-way system according to the instructions furnished with the kit, then adjust the two balance controls to obtain the correct loudness of the M.F. and H.F. units for proper overall balance, to suit the acoustics of your room. Do not forget to isolate the enclosure from the floor by means of 1/4 to 1/2 in. Ozite or rubber padding.

Now, listen to music!

**Acknowledgement**

The writer is indebted to Mr. J. F. Novak, Senior Design Engineer of the Jensen Manufacturing Company, for making available certain information concerning their special 15-inch woofer, and to Mr. Paul Croteau, of Quebec, another audio hobbyist, who had the kindness to review the composition of the manuscript. **AE**

**CLASSIFIED**

Rates: 10¢ per word per insertion for noncommercial advertisements; 25¢ per word for commercial advertisements. Rates are net, and no discounts will be allowed. Copy must be accompanied by remittance in full, and must reach the New York office by the first of the month preceding the date of issue.

THE AUDIO EXCHANGE has the largest selection of new and fully guaranteed used equipment. Catalog of used equipment on request. Audio Exchange, Dept. AE, 159-19 Hillside Avenue, Jamaica 32, N. Y. AXtel 7-7577; 367 Mamaroneck Ave., White Plains, N. Y. WH 8-3980; 836 Flatbush Ave., Brooklyn. BUCKminster 2-5300.

HIGH FIDELITY SPEAKERS REPAIRED  
Amprite Speaker Service  
70 Vesey St., New York 7, N. Y. BA 7-2580.

LOOKING FOR CLEAN RESPONSE TO 20 CYCLES? Listen to the radically new Racon "Hi-C" 15" foam suspension speaker. Racon Electric Co., Inc., 1261 Broadway, N.Y. 1, N.Y.

AMPEX MODEL 401, single case portable recorder 10" reels, 7 1/2-15 ips full track. Excellent condition. \$400.00. Write Voice of Faith, Inc. P. O. Box 1315, Tulsa, Oklahoma. Attention: Mr. L. R. Rex.

FOR SALE: AMPEX 350, 350-2, 600, 601, 601-2, and A-Series, available from stock at Grove Enterprises, Roslyn, Pa. TURNer 7-4277.

FAIRCHILD 202 ARM, \$40.00 or best offered, Henry Chow, 1750 Third, Detroit, Mich.

SPEAKER CABINETS  
Manufacturer's over run—brand name enclosures, genuine mahogany, completely finished, with or without speakers. 50% off Audiophile list. Write for details: Custom Craft, P. O. Box 304, Jasper, Indiana.

WANTED: Used Ampex Equipment, Box CB-1.

HI-FI SALE: Professional Reproduction System, Altec, Langevin components; RCA 77DX & 74B microphones; Hallicrafter Shortwave Receivers, Tuners; Audio Transformers. Foran. 3452 N. Hackett, Milwaukee, Wis.

CRAFTSMAN C-400 basic 10-watt amplifier. Ideal for second stereo amplifier or electronic crossover systems. Extra quality parts and transformers \$15. Excellent Condition. A. Turner, Box 22, Oakhurst, Calif.

WANTED: Genuine Klipschorn; must be in excellent condition. Robert Bowe, 4132 Drummond Road, Toledo, Ohio.

EXCEPTIONAL SAVINGS on Hi-Fi, speakers, components, amplifiers and tuners, tape recorders, etc. Write for individual quotations on your specific needs; no catalogs. Classified Hi-Fi Exchange, A, 2375 East 65th Street, Brooklyn 34, N. Y.

HIGH-FIDELITY custom installers part or full time basis. Nationally Advertised speaker manufacturer has money making proposition on exclusive basis for all areas. Box CB-2.

FOR SALE: Audak KT16 ARM assembled, unused, \$15. Electro-Voice Centurion enclosure with 105 speaker system \$286. Peter Keeatos, 624 Vanderbilt Ave., Brooklyn, N.Y.

**EMPLOYMENT**

This opportunity may come only once in your career. Electro-Voice is seeking a man with a thorough background in sound with emphasis on public address. This position will lead quickly to sales manager's level. Location at Buchanan, Michigan. Many benefits in addition to fine salary and an opportunity to be associated with the foremost industry leaders. New, fully air-conditioned offices in a location surrounded by lakes. You can choose small-town living in Buchanan or university-town living in South Bend. Write in complete confidence to L. LeKashman, Vice President of Sales, Electro-Voice Incorporated, Buchanan, Michigan.

## PROFESSIONAL DIRECTORY



### ANTENNAE

Get more FM stations with the world's most powerful FM Yagi Antenna systems.



Send 25¢ for booklet "Theme And Variations" containing FM Station Directory.

APPARATUS DEVELOPMENT CO.  
Wethersfield 9, Connecticut

Circle 79C

Continuously Since 1944

## HOLLYWOOD ELECTRONICS

DISTRIBUTORS OF HI-FI COMPONENTS EXCLUSIVELY

7400 Melrose Ave. Los Angeles 46, Calif. - WEbster 3-8208

Circle 79D

CANADA  
High Fidelity Equipment  
Complete Lines • Complete Service  
Hi-Fi Records — Components and Accessories

## ELECTRO-VOICE SOUND SYSTEMS

141 DUNDAS ST. WEST, TORONTO, CANADA

Circle 79E

the finest in Hi-Fi  
featuring **Electro-Voice**<sup>®</sup>  
HIGH FIDELITY COMPONENTS

820 W. Olympic Blvd. - L. A. 15, Calif. - RI 7-0271

Circle 79F

## HIGH-FIDELITY HOUSE

Most complete stock of Audio components in the West  
Phone: RYan 1-8171  
536 S. Fair Oaks, Pasadena 1, Calif.

Circle 79G

AN EYE FOR VALUE?  
Write us your hi-fi needs now — you'll be glad you did.  
Immediate replies. Complete stock.  
Dept. K2  
KEY ELECTRONICS CO.  
120 LIBERTY ST., N. Y. 6, N. Y.  
Phone: EVergreen 4-6071

Circle 79H

## Industry Notes...

Evidence of the snowballing interest in stereo discs is found in the announcement by **Audio Fidelity, Inc.**, that it will have available a catalog of twelve stereo selections within the near future. First of the series is now available to record companies and dealers for experimental and demonstration purposes. The Audio Fidelity discs are produced by the Westrex cutting system. The initial record features "The Dukas of Dixieland" on one side and "Railroad Sounds" on the other.

Full production and shipments are now in effect at the **Harman-Kardon, Inc.**, high fidelity plant in Westbury, N. Y., following a fire several weeks ago which caused estimated damage of \$250,000, according to Sidney Harman, president. Loss included two sub-assembly lines, the customer service department and a quantity of finished inventory. Major production lines, engineering department and offices were not affected. Another plant in Westbury larger than the one damaged has been leased and occupied.

**Electro-Voice, Inc.**, Buchanan, Mich., has established a marketing research division under the direction of William Wennerberg, formerly supervisor of industrial marketing research for **Armour & Co.**, Chicago meat packers. According to Albert Kahn, E-V president, the new division will be charged with developing improved marketing techniques, consumer and industrial surveys, and market and sales analysis.

The 1958 **San Francisco High Fidelity Show**, scheduled for February 14-16 at the Whitecomb Hotel, is aiming for a three-day attendance record of 20,000 visitors and will include packaged hi-fi exhibitors for the first time. Sponsored jointly by **Northern California Audio Shows, Inc.**, and the **Institute of High Fidelity Manufacturers, Inc.**, this year's show will place heavy emphasis on stereophonic sound and numerous closed-door demonstrations are anticipated. Exhibition hours will be noon to 9:30 p.m. and admission will be 75 cents.

A new departure in popularizing high fidelity at the consumer level was introduced recently when a **Parent-Teacher Association** of Whitesboro, N. Y., conducted a one-day Hi-Fi Fair which attracted nearly 2000 visitors. Dealers who exhibited nearly \$40,000 worth of equipment were highly elated with the high interest the event commanded, not to mention the fact that some sales were made from the floor. Ten per cent of the profits from the event were turned over to the Whitesboro PTA to finance scholarships for area youngsters.

**Columbia Records, Inc.**, is now at the top of the heap among all record companies, according to a recent announcement by Goddard Lieberman, president. In 1957 the company exceeded 1956 peak sales by nearly 50 per cent. On sales of phonograph records alone, Columbia jumped ahead of 1956 by more than 42 per cent, while the industry as a whole gained only 25 per cent, Mr. Lieberman stated. He made it plain that he was speaking in terms of dollar volume, not unit sales, in claiming top position for Columbia among all record manufacturers.

For the first time the public was afforded the opportunity of hearing the latest advances in stereo recording, both tape and disc, at a stereo symposium sponsored jointly by **Harvey Radio Company, Inc.**, and **Fairchild Recording Equipment Company.** Held in the WQXR auditorium in the New York Times building, the meeting played host to some 200 hi-fi enthusiasts who heard discussions covering all aspects of stereo by Anton Schmitt and James Carrol of Harvey's, and Chester Santon of WQXR. After the demonstrations the panel members answered questions from the audience.

### ROBINS' AUDIO ACCESSORIES

|                               |          |         |
|-------------------------------|----------|---------|
| 1. "Hobbyist"                 | H-4      | \$ 1.75 |
| 2. "Semi-Pro"                 | SP-4     | 3.50    |
| 3. Junior                     | TS4A-JR  | 6.50    |
| 4. Standard                   | TS4A-STD | 8.50    |
| 5. Deluxe                     | TS4A-DLX | 11.50   |
| 6. Industrial (5 sizes to 1") | (net)    | 55.00   |

### ROBINS' TAPE AND PHONO ACCESSORIES

|                                |          |      |
|--------------------------------|----------|------|
| 7. Splicing Tape               | ST-500   | .39  |
| 8. Head Cleaner                | HC-2     | 1.00 |
| 9. Jockey Cloth for Tapes      | JCT-2    | 1.00 |
| 10. Tape Storage Cans          | TC-7     | .80  |
| 11. Tape Threader              | TT-1     | .98  |
| 12. Changer Covers (2 sizes)   | CC-1,2   | 2.00 |
| 13. Turntable Covers (2 sizes) | CC-3,4   | 2.50 |
| 14. "Clean Sound" for Records  | CS-4     | 1.00 |
| 15. Jockey Cloth for Records   | JC-1     | 1.00 |
| 16. KleeNeedle                 | NB-1     | 1.50 |
| 17. Phono-Cushion, 10"x12"     | PC-10,12 | 1.50 |
| 18. Atomic Jewel               | SE-90    | 5.00 |
| 19. Acoustic Insulation        | AM-9     | 2.75 |

At Dealers Everywhere  
**ROBINS INDUSTRIES CORP.**  
BAYSIDE 61, NEW YORK

Circle 79A

startling silence  
for the perfectionist

## Connoisseur TURNTABLE



The hush of an empty church, even though the synchronous motor is running — this is the Connoisseur, crafted in traditional English quality. Precision machining assures pure sound reproduction. Non-magnetic, 12" lathe-turned table; precision ground spindle; phosphor bronze turntable bearing; ±2% variation provided for all 3 speeds; hysteresis motor. **\$110.00**

**TURNTABLE:** Rumble—better than 50 db down; Wow—less than 0.15% of rated speed; Dimensions: 13 1/4 x 15 1/4".

**PICKUP:** Frequency Response — 20-20,000 cps ±2 db at 33 1/3 rpm; Effective Mass—4 mg; Impedance—400 ohms at 1000 cps.

"Dynabalanced" tone arm with Mark II super-lightweight pickup w/diamond stylus **\$49.50**  
w/sapphire stylus **\$34.50**

Write today for literature.  
**ERCONA CORPORATION**  
(Electronic Division)  
551 Fifth Ave., Dept. 33, New York 17, N. Y.  
In Canada: Astral Electric Co. Ltd.  
44 Danforth Road, Toronto 18  
Circle 79B

... the ultimate goal  
of the  
critical listener

**marantz**

*Audio Console*  
pre-amplifier, complete \$171\*

*Power Amplifier*  
\$198\*

*Electronic Crossover*  
\$90\*

\*slightly higher west of  
the Mississippi

write for literature

**marantz company**

25-14 Broadway Long Island City 4, N. Y.

Circle 80A

for everything in **hi-fi**  
GET THE MONEY-SAVING 1958  
**ALLIED CATALOG**



featuring the  
world's largest  
stocks of systems  
& components

**free!**  
SEND FOR IT

Here's your complete money-saving guide to Hi-Fi. Own a fine custom quality Hi-Fi music system at no more than the cost of an ordinary phonograph. See dozens of ALLIED-Recommended complete Hi-Fi systems, plus the world's largest selection of components (amplifiers, tuners, changers, speakers, enclosures and accessories). Want to build-your-own?—see our exclusive Hi-Fi KNIGHT-KITS. For everything in Hi-Fi—for everything in Electronics, get the FREE 1958 ALLIED Catalog.

**ALLIED RADIO** AMERICA'S  
HI-FI CENTER

ALLIED RADIO CORP. Dept. 17-B8  
100 N. Western Ave., Chicago 80, Ill.

Send FREE 1958 ALLIED Catalog

Name \_\_\_\_\_

Address \_\_\_\_\_

City \_\_\_\_\_ Zone \_\_\_\_\_ State \_\_\_\_\_

Circle 80B

## ADVERTISING INDEX

|  |          |
|--|----------|
| Acoustic Research, Inc. ....                             | 61, 77   |
| Allied Radio Corporation .....                           | 80       |
| Altec Lansing Corporation .....                          | 53       |
| Ampex Audio, Inc. ....                                   | 54       |
| Apparatus Development Corporation ...                    | 79       |
| Audio Bookshelf .....                                    | 74       |
| Audio Devices, Inc. ....                                 | 2        |
| Audio Fidelity, Inc. ....                                | 43, 45   |
| Audiogersh Corporation .....                             | 6        |
| Belden .....   | 31       |
| Bell Telephone Laboratories .....                        | 16       |
| Bradford Audio Corp. ....                                | 56       |
| British Industries Corporation .....                     | 3        |
| facing p. 1, 3   |          |
| Capps & Co., Inc. ....                                   | 77       |
| Classified .....   | 78       |
| Connoisseur .....  | 79       |
| Datrel Company .....                                     | 66       |
| Dexter Chemical Corp. ....                               | 69       |
| Dynaco, Inc. ....  | 64, 65   |
| EICO .....   | 13       |
| Electro-Sonic Laboratories, Inc. ....                    | 51       |
| Electro-Voice, Inc. ....                                 | Cov. IV  |
| Electro-Voice Sound Systems .....                        | 79       |
| Ercona Corporation .....                                 | 79       |
| Fairchild Recording Equipment Co. ....                   | 55       |
| Ferrodynamics Corporation .....                          | 5        |
| Fisher Radio Corporation .....                           | 57       |
| Fourjay Industries .....                                 | 76       |
| Frazier International Electronics<br>Corporation .....   | 50       |
| Fukuin Electric (Pioneer) .....                          | 73       |
| Garrard Sales Corporation .....                          | 3        |
| Glaser-Steers Corporation .....                          | 37       |
| Grado Laboratories .....                                 | 58       |
| Harman-Kardon, Inc. ....                                 | 33       |
| Heath Company .....                                      | 8-11     |
| High Fidelity House .....                                | 79       |
| Hollywood Electronics .....                              | 79       |
| JansZen Speakers (Neshaminy Electronic<br>Corp.) .....   | 59       |
| Key Electronics .....                                    | 79       |
| Kierulff Sound Corporation .....                         | 79       |
| KLH Research and Development<br>Corporation .....        | 49       |
| Lansing, James B., Sound, Inc. ....                      | 47       |
| Leonard Radio, Inc. ....                                 | 75       |
| Marantz Company .....                                    | 80       |
| McIntosh Laboratory, Inc. ....                           | Cov. III |
| Mid-Continent Engineering, Inc. ....                     | 72       |
| Mullard Overseas, Ltd. ....                              | 7        |
| Orradio Industries, Inc. ....                            | 48       |
| Pentron .....  | 60       |
| Pickering and Company .....                              | 15       |
| Pilot Radio Corp. ....                                   | 41       |
| Presto, A Subsidiary of the Siegler<br>Corporation ..... | Cov. II  |
| Professional Directory .....                             | 79       |
| Radio Shack Corp. ....                                   | 63       |
| Rek-O-Kut Company .....                                  | 52       |
| Rigo Enterprises .....                                   | 4        |
| Robins Industries Corp. ....                             | 79       |
| Rockbar Corp. ....                                       | 29       |
| Schober Organ Corporation .....                          | 76       |
| Sherwood Electronic Laboratory, Inc. ..                  | 1        |
| Superscope Inc., Audio Electronics<br>Division .....     | 67       |
| Tannoy .....   | 71       |
| University Loudspeakers, Inc. ....                       | 39       |
| Viking of Minneapolis .....                              | 35       |
| Weathers Industries, Inc. ....                           | 27       |



Ridiculous, you say.  
Delay can't *kill* anyone.  
It isn't a disease.

Yet last year, of the 250,-  
000 Americans who were  
cancer's victims, 75,000  
died *needlessly*. 75,000!...  
the populations of cities  
like Charleston, Santa  
Monica, or Racine. They  
might have been saved...  
but they put off seeing  
their doctors until it was  
too late. Their story is told  
in our dramatic film "The  
Other City"... a film  
which can save thousands  
of lives. Perhaps your own.  
It teaches you the seven  
danger signals by which  
early cancer often reveals  
itself, and emphasizes your  
need for an annual health  
checkup as your best insur-  
ance against cancer.

"The Other City" is avail-  
able, without charge, for  
showing at your church,  
your club, your community  
center, plant or office.

To arrange to see this and  
other life-saving films,  
made possible by your con-  
tributions, call the Unit of  
the American Cancer Soci-  
ety in your community or  
write to "Cancer" in care  
of your local post office.

**AMERICAN  
CANCER  
SOCIETY**

McIntosh Laboratories, Inc.  
2 Chambers Street, Dept. 6  
Binghamton, New York

Please send me a full color photograph of the  
McIntosh MR-55 A.M.-F.M. tuner . . . The tuner that  
"keeps the promise of F.M."

NAME .....

ADDRESS .....

CITY ..... ZONE .....

STATE .....

---



the

# McIntosh Tuner

Silence . . . to Music . . . to Silence . . . McIntosh developed ultra-sonic squelch results in complete quiet between stations. Absolutely no noise, no crackling, no thumping, no tearing sound as you tune a station, just . . . Silence . . . to Music . . . to Silence . . . Here, finally, is a tuner that "keeps the promise of F.M." See your franchised McIntosh dealer for a demonstration of the McIntosh tuner.

# Electro-Voice®

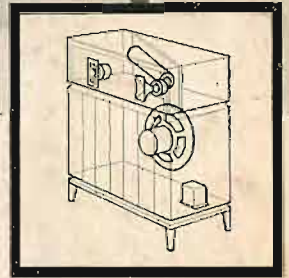
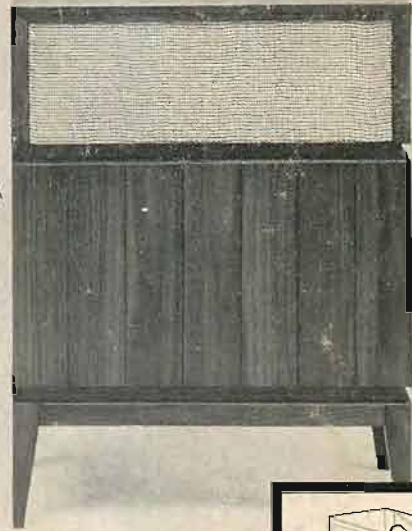

## Here is Why Electro-Voice Phase Loading Improves Along-the-Wall High-Fidelity Reproduction

**Phase Loading**—a great Electro-Voice development—gives you performance from along-the-wall speaker enclosures that approaches the performance of a corner horn! Specifically designed for use along-the-wall, phase-loaded cabinets give you almost a full added octave of smooth, augmented bass. The bass driver unit is placed low and close to the rear reflecting wall so that the direct sound from the cone and the reflected sound reach the listener's ears from very nearly the same source. This prevents phase cancellations, gives smooth, augmented bass range.

**Phase Loading** also permits a sealed cavity behind the driver cone of precise volume. The compliance of this cavity is made to react with the mass of the cone and the outside air throughout the second octave, adding this range to the response not otherwise attainable. This is *why* Phase Loading is demonstrably superior. Hear it today!

### NEW ELECTRO-VOICE PHASE LOADED ENCLOSURES

**The Carlton IV.** Smart, handsome low-boy design using acoustically correct "Tapatex" grille cloth for accent. It harmonizes gracefully with modern furnishings. Employs a complete *phase loaded* system affording extended bass response range with smooth, resonance-free characteristics. Includes Model 105E deluxe 15-inch, 4-way components completely wired and installed. Size: 33½" high, 26¼" wide, 19½" deep. Mahogany Complete—Net each.....\$359.00

**The Sheraton.** Complements the Carlton phase loaded speaker enclosure, affording extensive facilities for amplifier, tuner, turntable or record changer, tape deck plus record and tape storage. Compartment dimensions: Record Player, 18" long x 17¼" wide x 9½" overall depth (adjustable mounting board raises for manual player); Amplifier-tuner, 18" long x 17¼" deep; Storage, 13" high x 19" wide x 17¼" deep. Overall size: 33½" high x 37½" wide x 19½" deep. Mahogany Cabinet Only—Net each.....\$173.00

### THERE'S AN ELECTRO-VOICE PHASE LOADED ENCLOSURE FOR EVERY APPLICATION

**The Suzerain IV.** With phase loaded Model 105E 15-inch deluxe speaker system, wired and installed. Size: 36½" high x 26" wide x 19¼" deep. Mahogany Complete—Net each.....\$395.00

**The Suzerain IVA.** Model 117B 15-inch standard speaker system, wired and installed. Same size as Suzerain IV. Mahogany Complete—Net each.....\$301.00

**The Carlton IVA.** Similar to Carlton IV but with economy Model 117B 15-inch standard speaker system, wired and installed. Mahogany Complete—Net each.....\$265.00

**The Duchess IV.** Model 105E 15-inch deluxe speaker system, wired and installed. Size: 29¾" high x 25" wide x

19" deep. Mahogany Complete—Net each.....\$356.00

**The Duchess IVA.** Model 117B 15-inch standard speaker system, wired and installed. Same size as Duchess IV. Mahogany Complete—Net each.....\$262.00

**The Empire IV.** Model 105E deluxe 15-inch 4-way components wired and installed. Size: 29¾" high x 32" wide x 16" deep. Mahogany Complete—Net each.....\$359.00

**The Empire IVA.** Model 117B 15-inch standard speaker system, wired and installed. Same size as Empire IV. Mahogany Complete—Net each.....\$265.00

All Electro-Voice furniture is available in Blonde Lined Oak or Circassian Walnut at slightly higher price. Enclosures may be purchased separately, without speaker systems.

Electro-Voice offers you this wide selection of phase loaded speaker systems and enclosures, each carefully made by dedicated craftsmen, designed by the industry's best engineers and stylists to integrate with either modern, traditional or contemporary furnishings.

NO FINER CHOICE THAN

# Electro-Voice

ELECTRO-VOICE, INC.

BUCHANAN, MICHIGAN

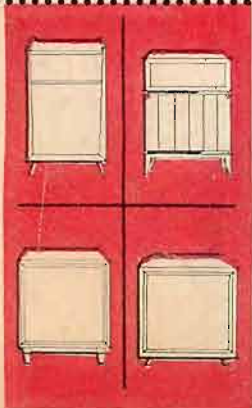



**AUDIO FIDELITY\***

**records presents  
the world's first  
compatible  
stereophonic  
long-play records**

**STEREODISC!\***

\*Reg. App. for

**TECHNICAL DATA**

**FIRST** major development in phonograph records since the transition from cylinder to disc.

**FIRST** in a series of special Stereodisc versions of hits from the AUDIO FIDELITY catalog.

# WHAT IS STEREOPHONIC SOUND?

Ordinary high fidelity sound has to come through a loudspeaker. If you use two loudspeakers, the program can come to you through both of them, like two holes in the wall. But when you use stereophonic recordings, each loudspeaker brings you a different part of the total sound, so the program—orchestra, jazz ensemble, railroad train or what-have-you can re-assemble itself *in your listening room*.

This is not the same as a multiway loudspeaker system, where separate loudspeaker units are used to handle the different frequencies, one for bass, one for treble, and one for the very high overtones that add definition and clarity to the reproduction. Stereophonic sound requires *two program channels*, each of which carries the full frequency range, bass, treble, and super-overtones.

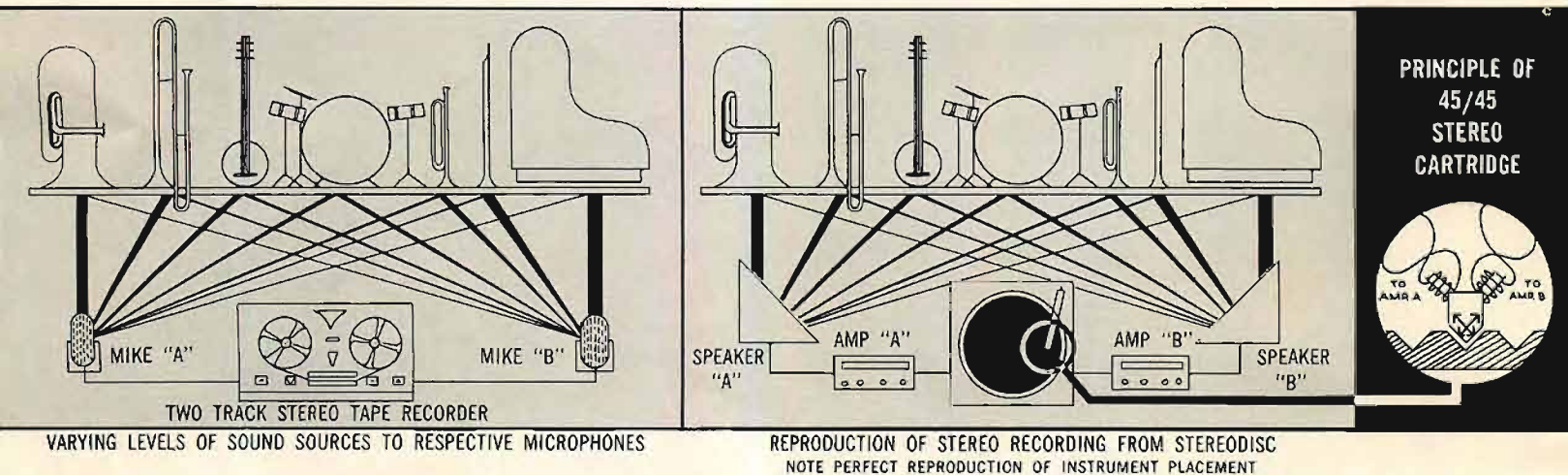

## HOW DO YOU PUT TWO CHANNELS ON ONE DISC?

A conventional LP has a groove that wiggles from side to side to correspond with all the frequencies in the program, from 16 cycles to 25,000 cycles as on an AUDIO FIDELITY record. But the groove stays level, it does not go up and down. For stereophonic recordings, each channel, one for the left loudspeaker and one for the right, makes the groove go both up-and-down and sideways at the same time. But the combination is different for each channel. This enables the specially-designed *stereo* pickup to separate the vibrations from a single groove and produce *two* high-quality program outputs at the same time without getting them mixed. Each channel from the pickup must be amplified with a separate amplifier connected to its own loudspeaker.

## HOW CAN I GET THE BEST RESULTS FROM THE STEREO RECORD?

Now you have the stereophonic program and you want to use your loudspeakers to give the best possible rendition. First choose good—but not necessarily expensive—loudspeakers. The important things are that they have a *smooth* frequency response (give uniform rendition of all musical tones) and that (especially with the more elaborate types) the sound is well integrated from each speaker in the system. (Adequate dispersion or spreading of the high notes is very important in stereo — check speakers for good diffraction).

Separate loudspeaker systems spaced apart will usually sound better for stereophonic sound. If the room is small (say 12' by 14' or less) a built-in console type system with the speakers placed at either end of the cabinet should sound quite well. Furnishing and arrangement can make quite a difference, so these rules for speaker placement are flexible. Experimentation is the only way to be sure that you have the best set-up for your room.

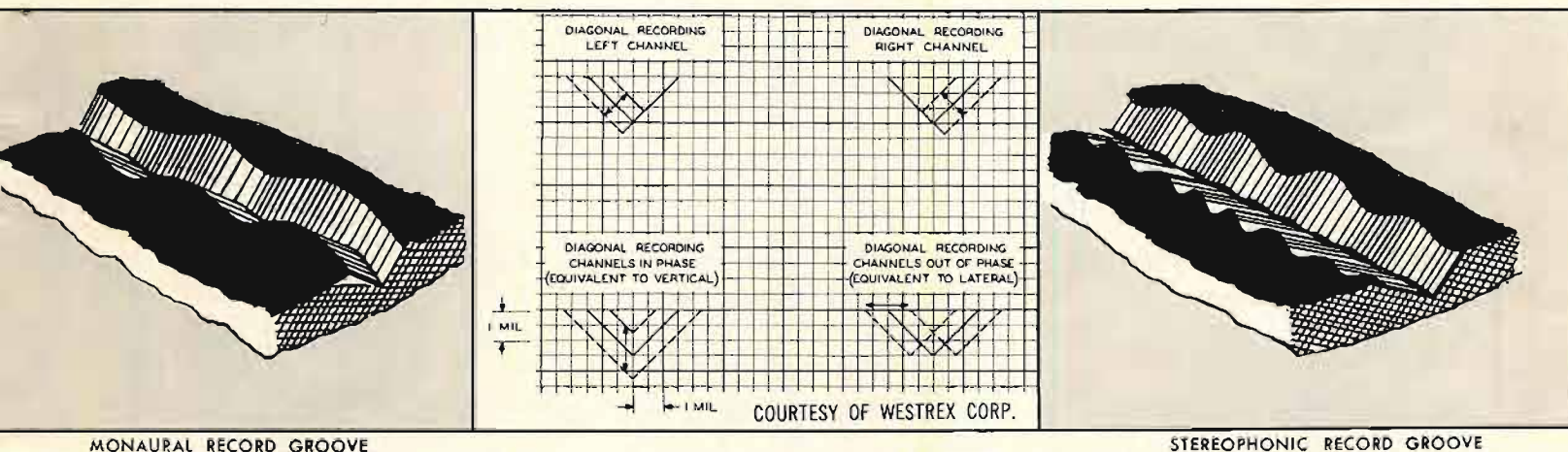

MONAURAL RECORD GROOVE

STEREOPHONIC RECORD GROOVE

## WHAT CAN I PLAY WITH WHAT?

An *Audio Fidelity* record can be played with any pickup, but naturally you want to get the best from it. A stereo disc should be played with a stereo pickup. It will play with an old style LP pickup, and will give high fidelity sound that way. But it will not produce stereophonic sound that way. And many old style LP pickups, though quite good for their own purpose, may not be compatible, although they sound alright as high fidelity. We advise *playing stereo recordings only with stereo pickups*.

However a stereo pickup will play the older *Audio Fidelity* and other high fidelity records. But it will still only sound like high fidelity. You need both a stereo pickup *and* a stereo record to get real stereophonic reproduction.

# AF STEREO DISC\* RELEASES

Sealed in protective Polyethylene case, complete with technical data.

EACH AUDIO FIDELITY STEREO DISC\* 12 INCH STEREOGRAPHIC LONG PLAYING RECORD \$6.95



AFSD 1849



AFSD 1830



AFSD 1860



AFSD 1877



AFSD 1833



AFSD 1851



AFSD 1848

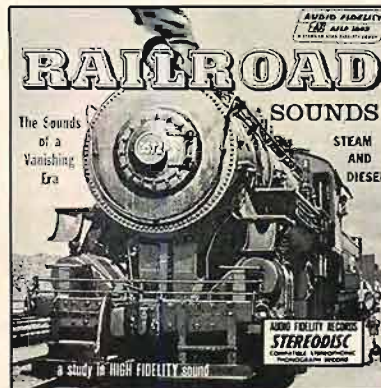

AFSD 1843



AFSD 1825



AFSD 1844



AFSD 1857



AFSD 1835

Watch For New Releases!

AUDIO FIDELITY INC. • 770 Eleventh Avenue • New York 19, N. Y.  
 IN BRAZIL: SINTER AUDIO FIDELITY • AUDIO FIDELITY CANADA LTD. • IN ARGENTINA: AUDIO FIDELITY

\*REG. APP. FOR

©COPYRIGHT 1958 BY AUDIO FIDELITY INC.